

# KEY RESIN COMPANY STANDARD FLOORING DESIGN DETAILS GUIDE

*Click to link  
directly to the  
design detail  
of your choice.*

VAPOR BARRIER FOR SLAB ON GRADE	KEY-DTL-1	PRECAST EPOXY TERRAZZO COVE BASE	KEY-DTL-19
CONTRACTION/CONTROL JOINT	KEY-DTL-2	SPECIAL JOINT DETAILS – RESINOUS FLOOR	KEY-DTL-20
EXPANSION/ISOLATION JOINT	KEY-DTL-3	COVE DETAIL #4	KEY-DTL-21
CONSTRUCTION/COLD JOINT	KEY-DTL-4	RESINOUS STAIR NOSING DETAIL	KEY-DTL-23
BURIED CONTROL JOINT/CRACK TREATMENT	KEY-DTL-5	RISER TREAD DETAIL	KEY-DTL-24
EPOXY TERRAZZO-CARPET/VCT TERMINATION	KEY-DTL-6	COVE DETAIL #5 – RESINOUS FLOOR	KEY-DTL-25
EPOXY FLOORING KEY-IN TERMINATION	KEY-DTL-7	SAW CUT EXPANSION JOINT – RS FLR	KEY-DTL-26
EPOXY FLOORING STEPS OVER CONCRETE	KEY-DTL-8	COVE DETAIL #6 – 8” RESINOUS COVE	KEY-DTL-27
EPOXY FLOORING OVER CEMENT/EPOXY FILL	KEY-DTL-9	RESINOUS FLOOR/CARPET TILE TERMINATION	KEY-DTL-28
FLANGED DRAIN DETAIL	KEY-DTL-10	CANT COVE DETAIL – RESINOUS FLOOR	KEY-DTL-29
TRENCH DETAIL	KEY-DTL-11	ABRASIVE NON-SLIP LINES	KEY-DTL-30
COVE DETAIL #1	KEY-DTL-12	COVE DETAIL – RESINOUS FLOOR/WALL	KEY-DTL-31
COVE DETAIL #2	KEY-DTL-13	JOINT TREATMENT – WOOD/CEMENT BOARD	KEY-DTL-32
COVE DETAIL #3 – RESINOUS FLOOR	KEY-DTL-14	RESINOUS FLOOR/CERAMIC TILE TERMINATION	KEY-DTL-33
CONTROL JOINT – RESINOUS FLOOR	KEY-DTL-15	COVE DETAIL #7 – OVER EXPANSION JOINT	KEY-DTL-34
PRECAST TERRAZZO THRESHOLD	KEY-DTL-16	COVE DETAIL #8 – RESINOUS W/ STRIPS	KEY-DTL-35
TERRAZZO STEP TERMINATION DETAIL	KEY-DTL-17	TERRAZZO OVERLAY TRANSITION	KEY-DTL-36
RISER TREAD DETAIL	KEY-DTL-18	PIPE PENETRATION DETAIL	KEY-DTL-37



4050 Clough Woods Drive  
Batavia, Ohio 45103  
888-943-4532  
[www.keyresin.com](http://www.keyresin.com)

DATE:  
03/31/17

DETAIL:  
**TABLE OF CONTENTS – PG 1 OF 2**

FILE #:  
**KEY RESIN FLOORING DETAIL DWGS**

# KEY RESIN COMPANY STANDARD FLOORING DESIGN DETAILS GUIDE

*Click to link  
directly to the  
design detail  
of your choice.*

COVE BASE ON STAINLESS STEEL	KEY-DTL-38
TYPICAL MRI SUITE FLOORING DETAIL	KEY-DTL-39
KEY CONDUCTIVE EPOXY TERRAZZO	KEY-DTL-40
COVE DETAIL #9 – INTEGRAL WITH IMP	KEY-DTL-42
COVE DETAIL #10 – CANT WITH IMP	KEY-DTL-42
COVE DETAIL #11 – TILE WALL #1 COVE	KEY-DTL-43
DETAIL #12 – TILE WALL #2 FLANGED	KEY-DTL-44
DRAIN WATERPROOFING RESINOUS	KEY-DTL-45
FLOORING TERMINATION PIPE	KEY-DTL-46
PENETRATION DETAIL #2 STRIPLESS	KEY-DTL-47
EXPANSION JOINT DETAIL KEY	KEY-DTL-48



4050 Clough Woods Drive  
Batavia, Ohio 45103  
888-943-4532  
[www.keyresin.com](http://www.keyresin.com)

DATE:  
03/31/17

DETAIL:  
TABLE OF CONTENTS – PG 2 OF 2

FILE #:  
KEY RESIN FLOORING DETAIL DWGS

Click For Table of Contents

NOTE:  
DO NOT PLACE 2" OF SAND  
OVER VAPOR BARRIER  
REFERENCE ACI-302.IR-04

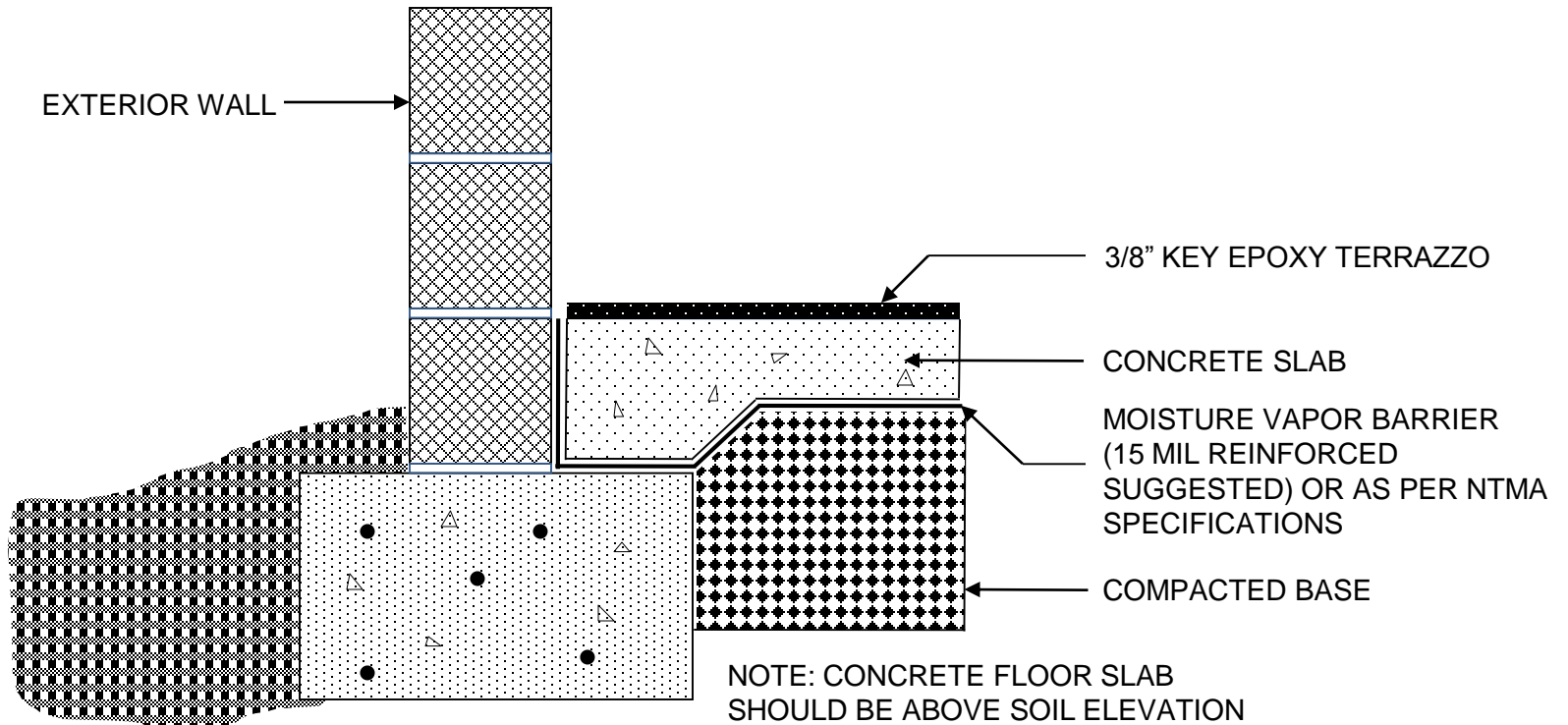

4050 Clough Woods Drive  
Batavia, Ohio 45103  
888-943-4532  
[www.keyresin.com](http://www.keyresin.com)

NOT TO  
SCALE  
DATE:  
2/24/08

DETAIL: **VAPOR BARRIER FOR SLAB ON GRADE**  
FILE #: **KEY-DTL-1**

Click For Table of Contents

# CONTRACTION/ CONTROL JOINT

PREFERRED   ALTERNATE

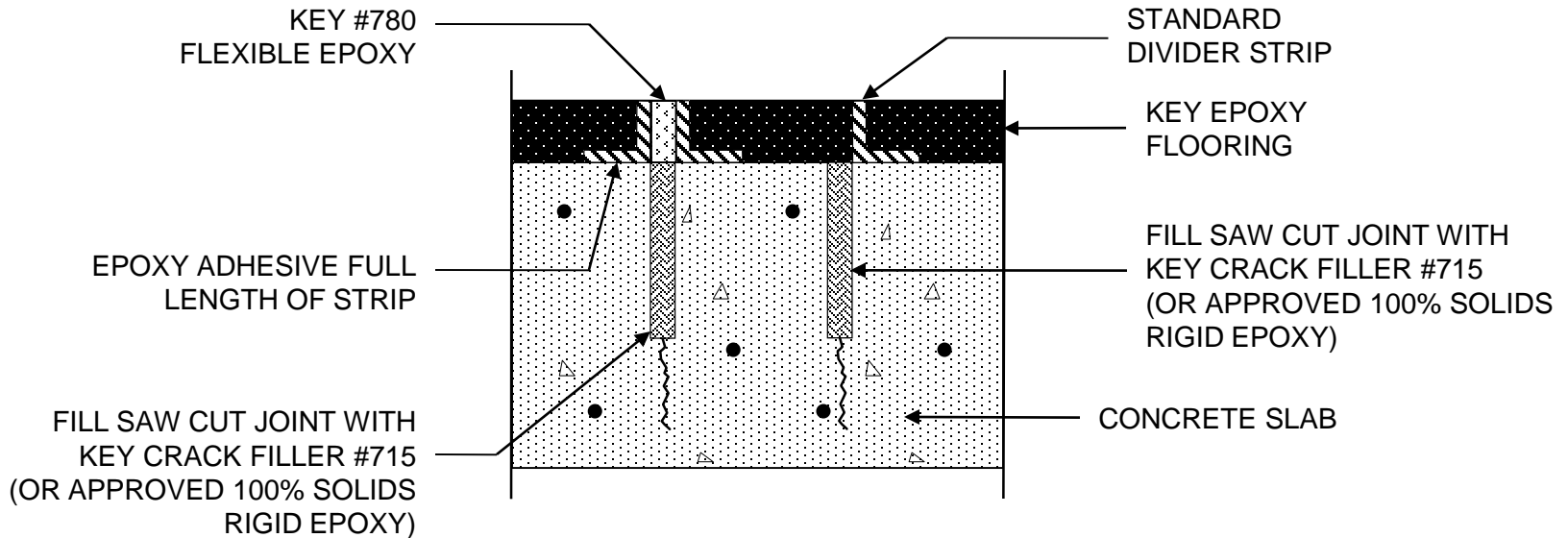

NOTE 1: THIS DETAIL MUST BE USED FOR RADIANT HEATED FLOORS.

OPTION: FOR "ART WORK AREAS," SEE BURIED CONTRACTION JOINT DETAIL. REFER TO DETAIL # KEY-DTL-5



4050 Clough Woods Drive  
Batavia, Ohio 45103  
888-943-4532  
[www.keyresin.com](http://www.keyresin.com)

NOT TO  
SCALE

DATE:  
10/28/10

DETAIL: **JOINT DETAILS**

FILE #: **KEY-DTL-2**

Click For Table of Contents

## EXPANSION / ISOLATION JOINT

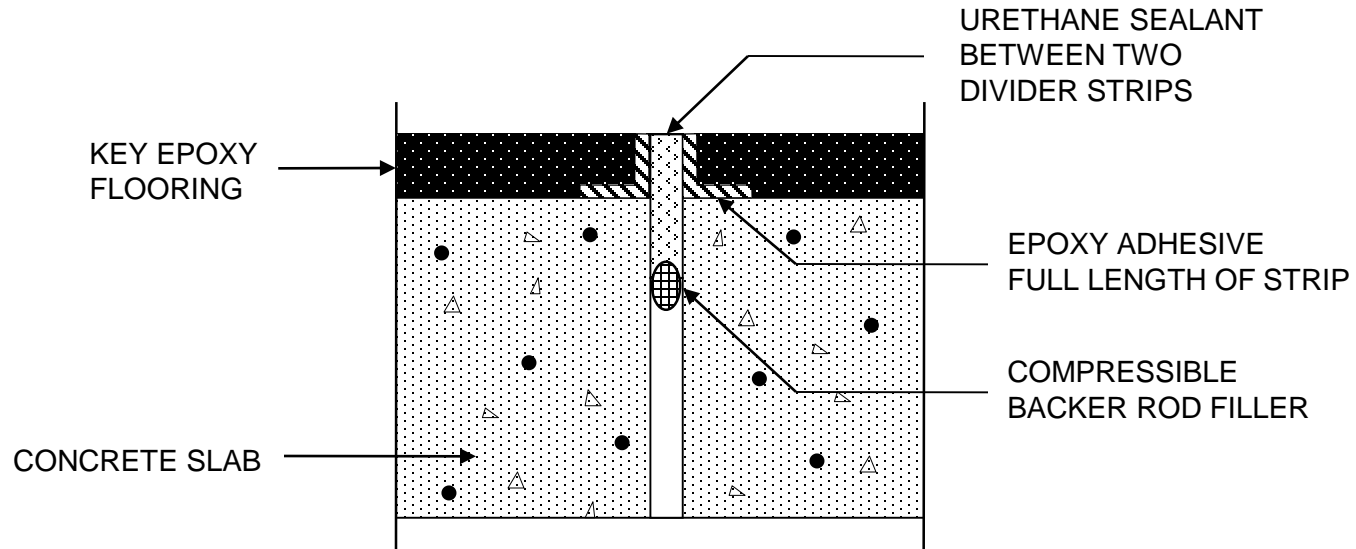

4050 Clough Woods Drive  
Batavia, Ohio 45103  
888-943-4532  
[www.keyresin.com](http://www.keyresin.com)

NOT TO  
SCALE

DATE:  
01/04/10

DETAIL:  
**JOINT DETAILS**

FILE #:  
**KEY-DTL-3**

Click For Table of Contents

## CONSTRUCTION / COLD JOINT (Next Day Pour Where Joint Has Eased Shoulders or Has Opened)

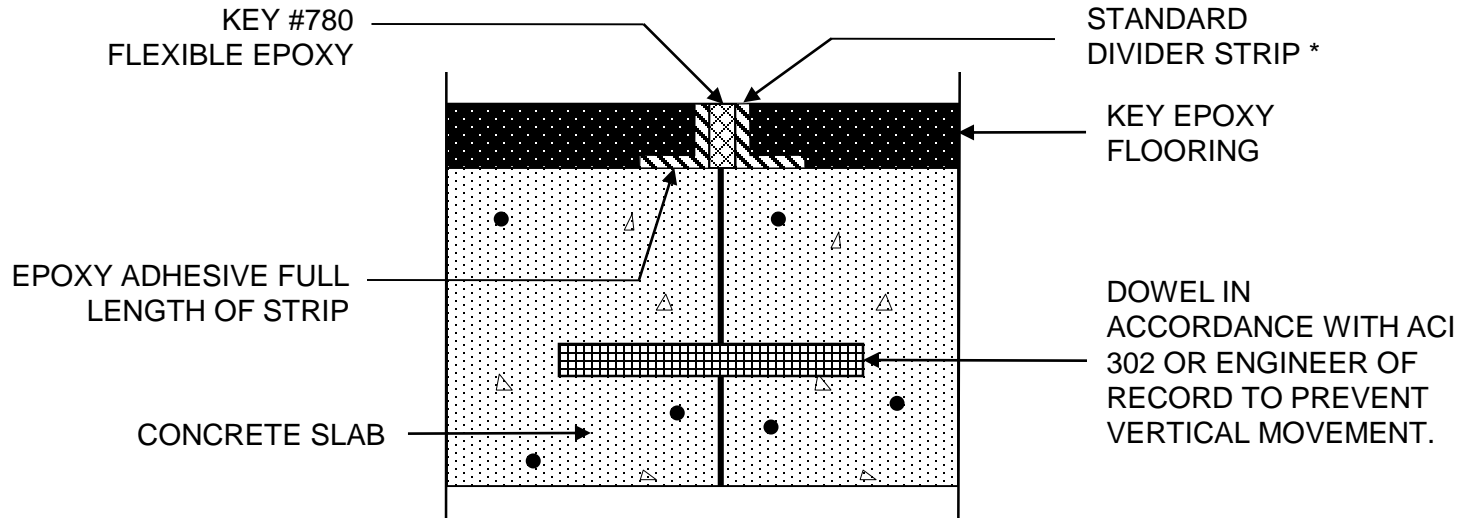

\* IF CONSTRUCTION/COLD JOINT HAS NOT  
OPENED, STRIPS MAY BE SET BACK TO BACK

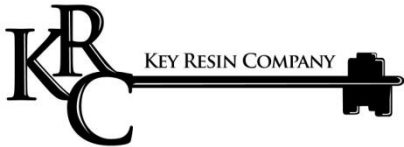

4050 Clough Woods Drive  
Batavia, Ohio 45103  
888-943-4532  
[www.keyresin.com](http://www.keyresin.com)

NOT TO  
SCALE

DATE:  
01/04/10

DETAIL:  
JOINT DETAILS

FILE #:  
KEY-DTL-4

Click For Table of Contents

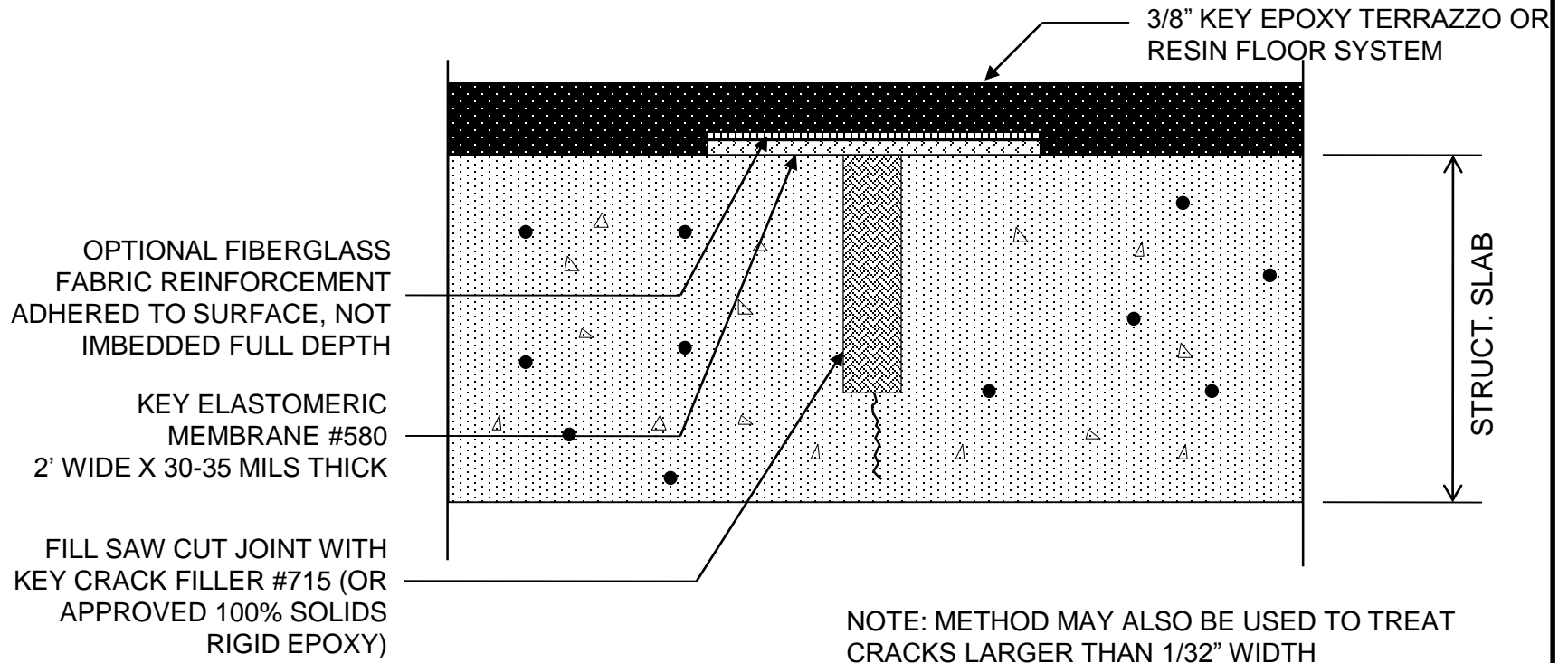

TREATMENT OF CONTRACTION JOINTS (SAWCUTS) AND CRACKS IS DONE IN ANTICIPATION OF HORIZONTAL MOVEMENT



4050 Clough Woods Drive  
Batavia, Ohio 45103  
888-943-4532  
[www.keyresin.com](http://www.keyresin.com)

NOT TO SCALE  
DATE: 10/28/09

DETAIL: BURIED CONTROL JOINT/CRACK TREATMENT  
FILE #: KEY-DTL-5

Click For Table of Contents

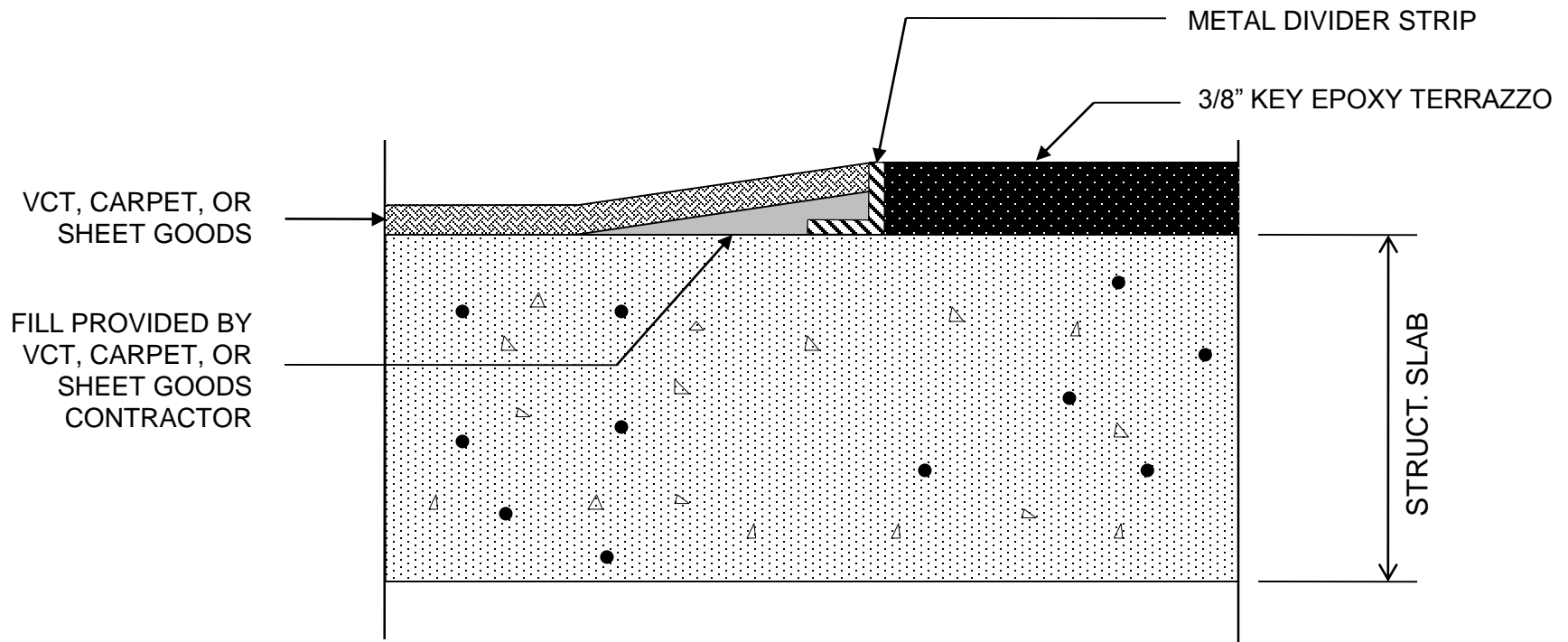

NOTE: EPOXY TERRAZZO TO BE POURED FIRST.  
OTHER TRADES TO FINISH AT PROPER ELEVATION



4050 Clough Woods Drive  
Batavia, Ohio 45103  
888-943-4532  
[www.keyresin.com](http://www.keyresin.com)

NOT TO  
SCALE

DATE:  
2/24/08

DETAIL:  
EPOXY TERRAZZO, CARPET TERMINATION

FILE #:  
KEY-DTL-6

*Click For Table of Contents*

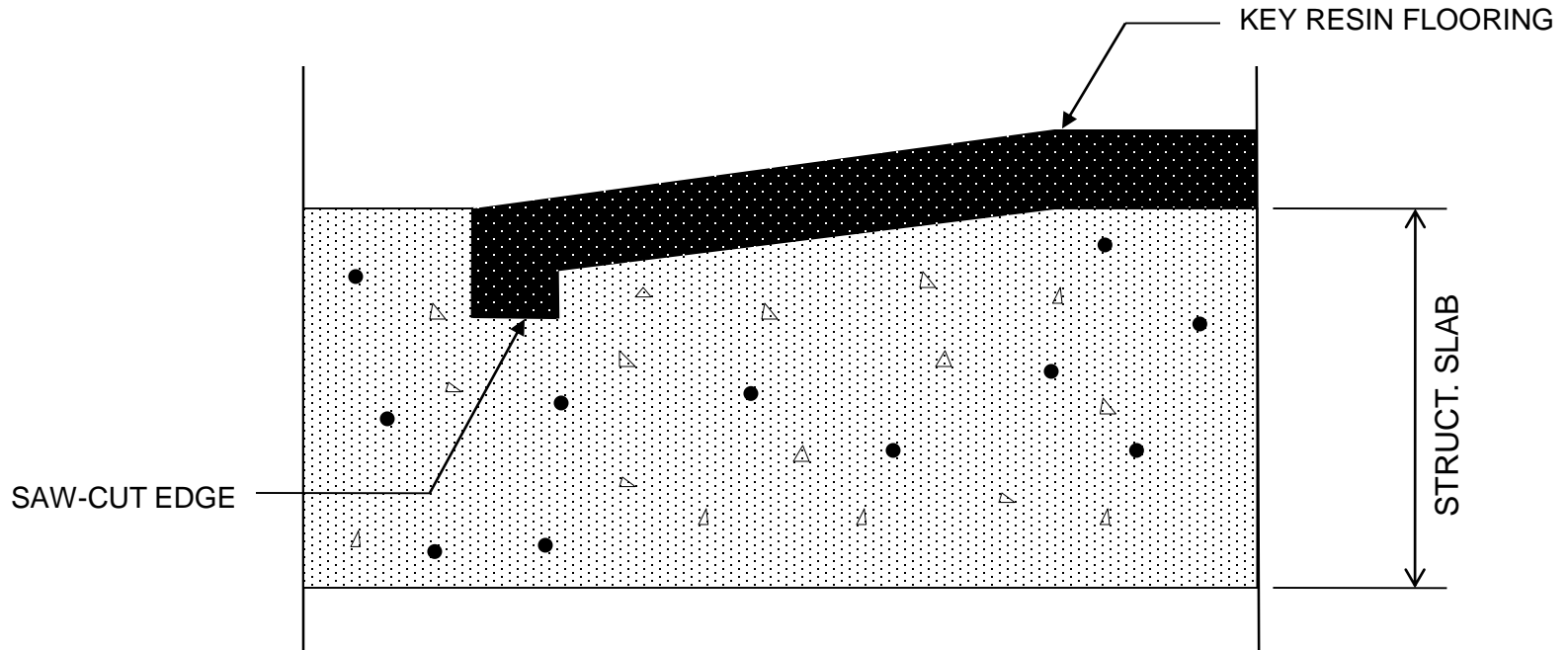

4050 Clough Woods Drive  
Batavia, Ohio 45103  
888-943-4532  
[www.keyresin.com](http://www.keyresin.com)

NOT TO  
SCALE

DATE:  
**2/24/08**

DETAIL:  
**EPOXY FLOORING KEY-IN TERMINATION**

FILE #:  
**KEY-DTL-7**

*Click For Table of Contents*

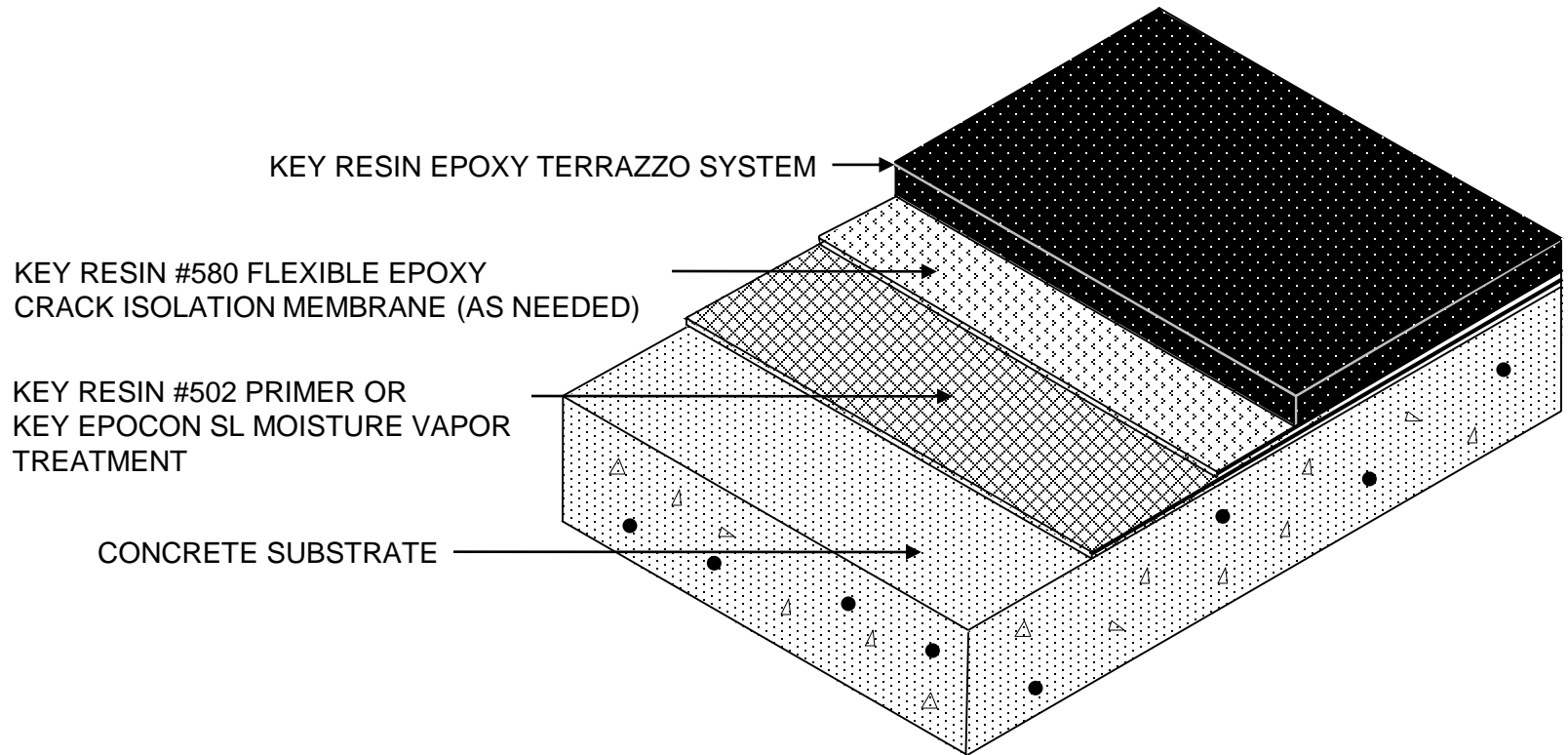

4050 Clough Woods Drive  
Batavia, Ohio 45103  
888-943-4532  
[www.keyresin.com](http://www.keyresin.com)

NOT TO  
SCALE

DATE:  
**2/24/08**

DETAIL: **EPOXY TERRAZZO OVER CONCRETE**

FILE #: **KEY-DTL-8**

*Click For Table of Contents*

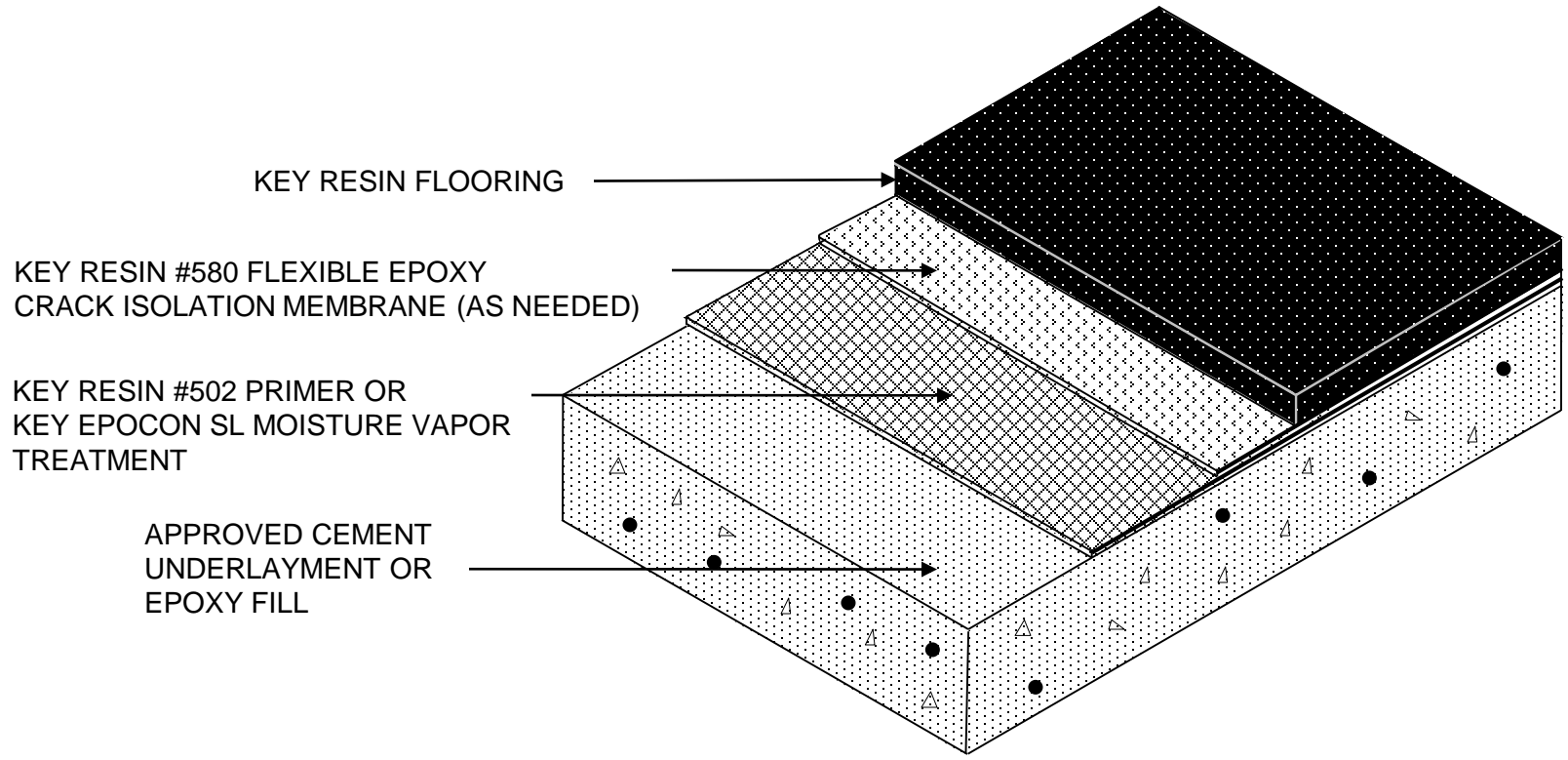

4050 Clough Woods Drive  
Batavia, Ohio 45103  
888-943-4532  
[www.keyresin.com](http://www.keyresin.com)

NOT TO  
SCALE

DATE:  
10/28/10

DETAIL:  
EPOXY FLOORING OVER EPOXY/CEMENT FILL

FILE #:  
KEY-DTL-9

Click For Table of Contents

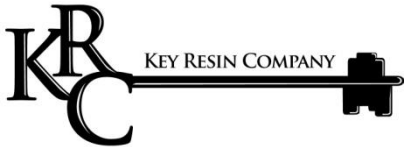
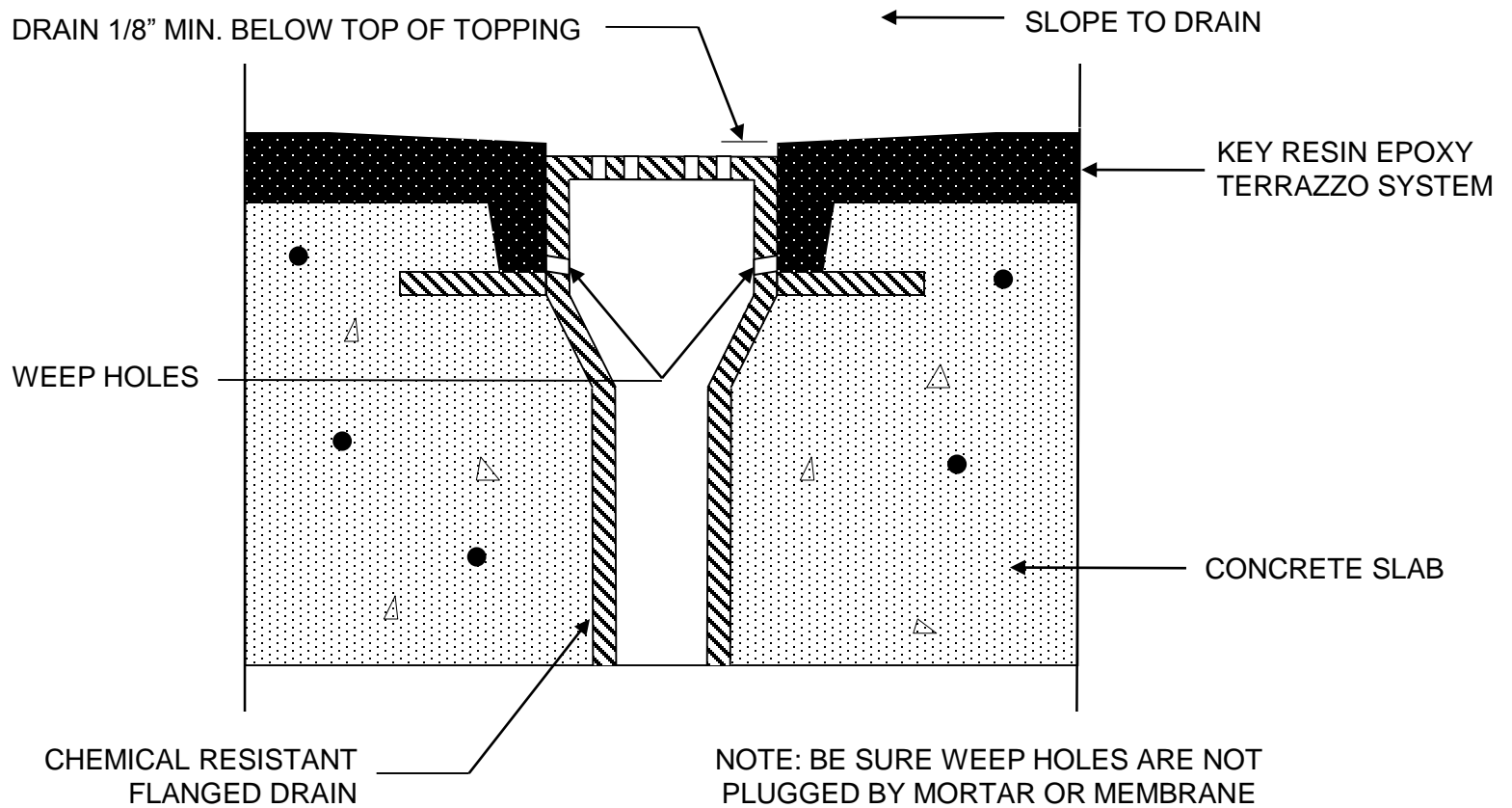

4050 Clough Woods Drive  
Batavia, Ohio 45103  
888-943-4532  
[www.keyresin.com](http://www.keyresin.com)

NOT TO  
SCALE

DATE:  
2/24/08

DETAIL:  
**FLANGED DRAIN DETAIL - TERRAZZO**

FILE #:  
**KEY-DTL-10**

Click For Table of Contents

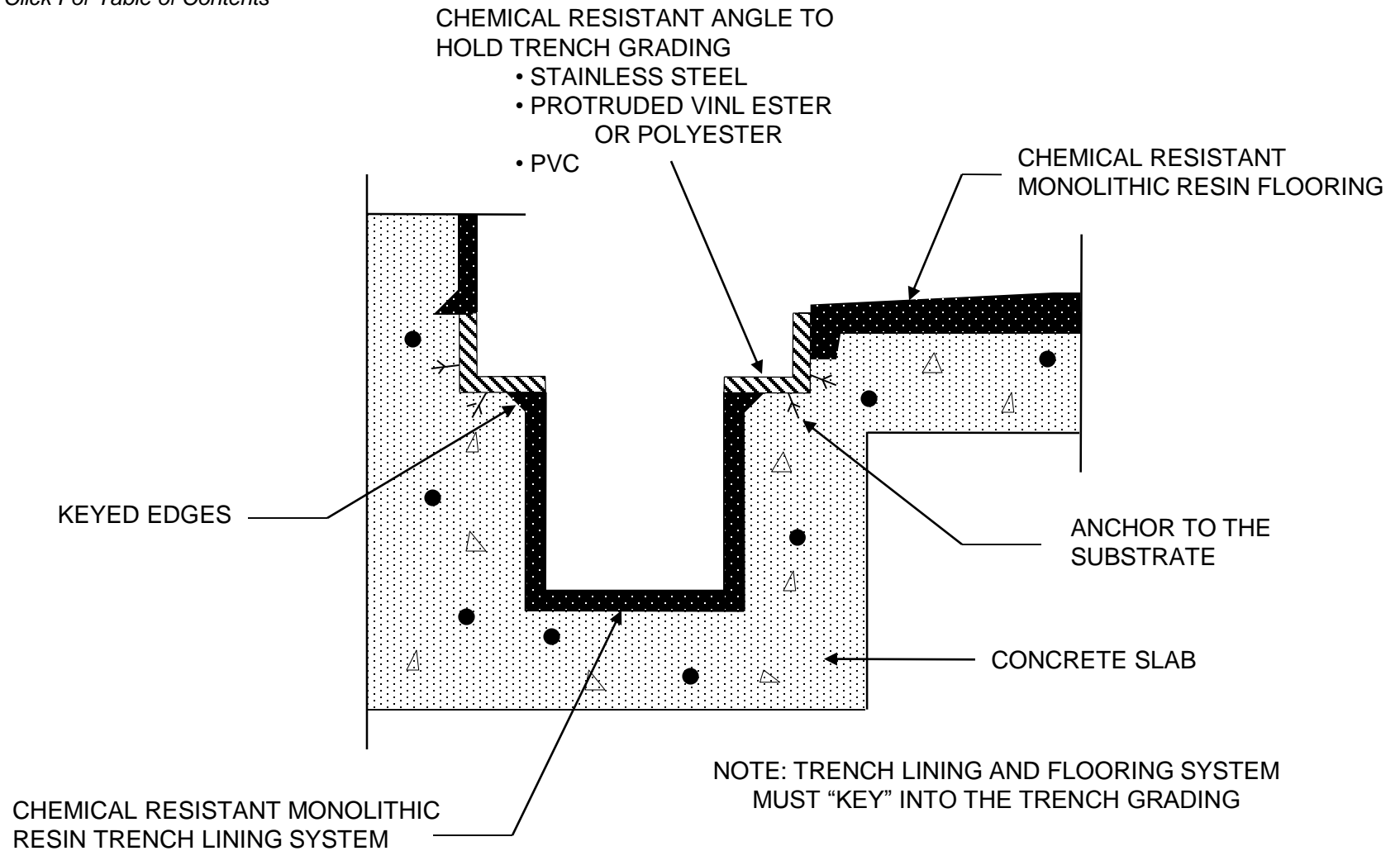

4050 Clough Woods Drive  
Batavia, Ohio 45103  
888-943-4532  
[www.keyresin.com](http://www.keyresin.com)

NOT TO  
SCALE

DATE:  
2/24/08

DETAIL:  
**TRENCH DETAIL**

FILE #:  
**KEY-DTL-11**

Click For Table of Contents

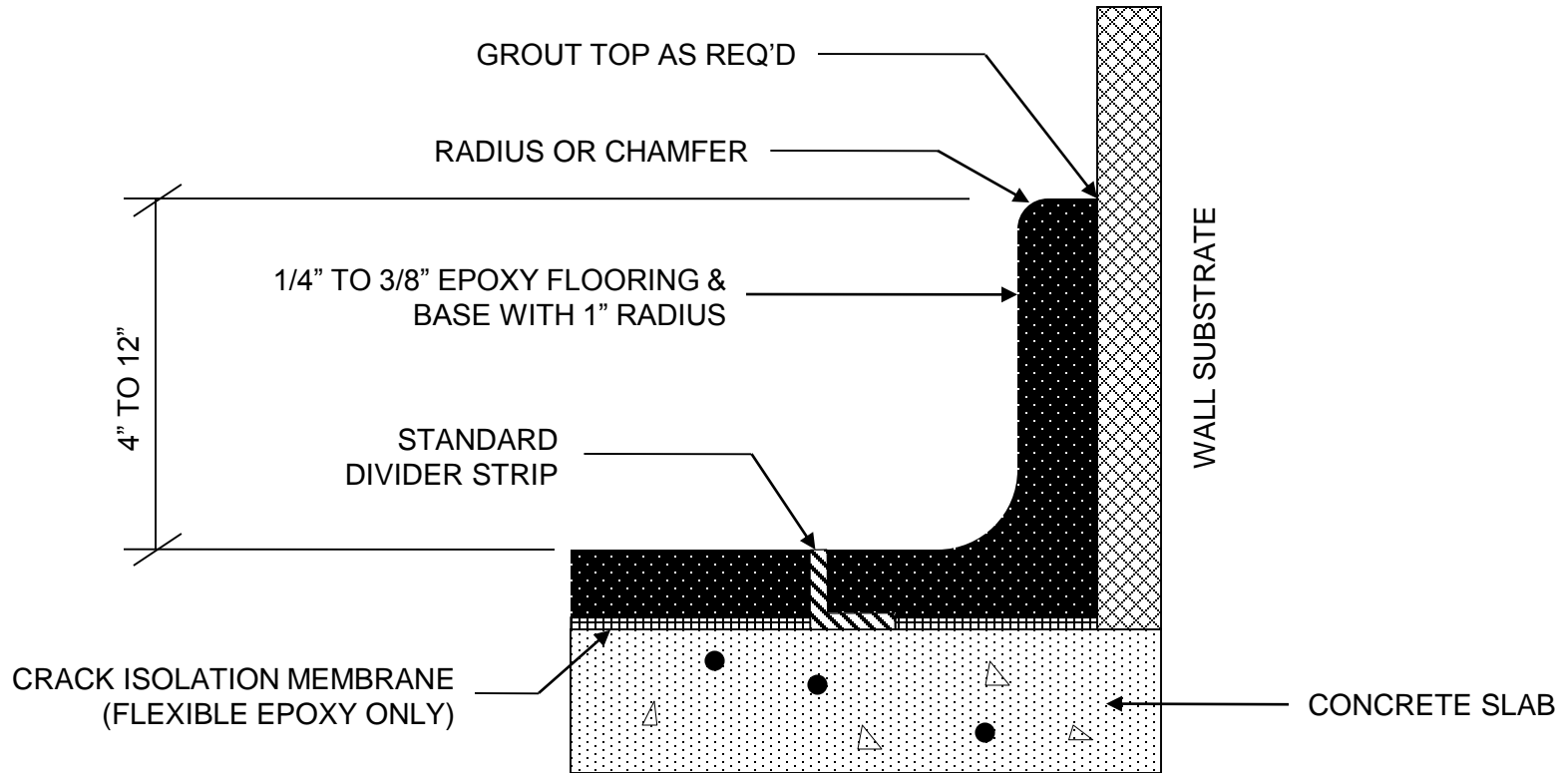

4050 Clough Woods Drive  
Batavia, Ohio 45103  
888-943-4532  
[www.keyresin.com](http://www.keyresin.com)

NOT TO  
SCALE  
DATE:  
2/24/08

DETAIL:  
**COVE DETAIL #1**  
FILE #:  
**KEY-DTL-12**

*Click For Table of Contents*

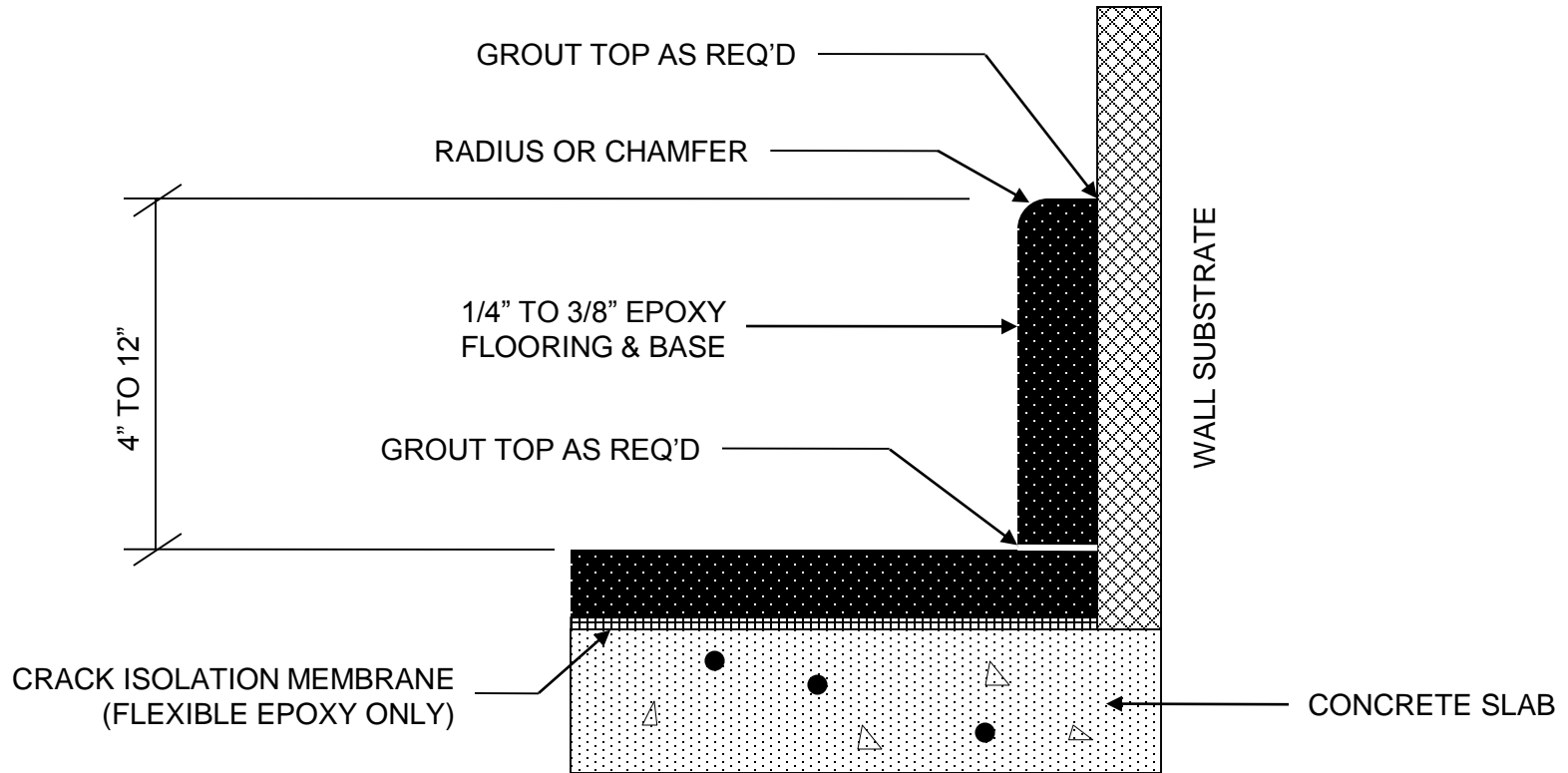

4050 Clough Woods Drive  
Batavia, Ohio 45103  
888-943-4532  
[www.keyresin.com](http://www.keyresin.com)

NOT TO  
SCALE

DATE:  
2/24/08

DETAIL:  
**COVE DETAIL #2**

FILE #:  
**KEY-DTL-13**

Click For Table of Contents

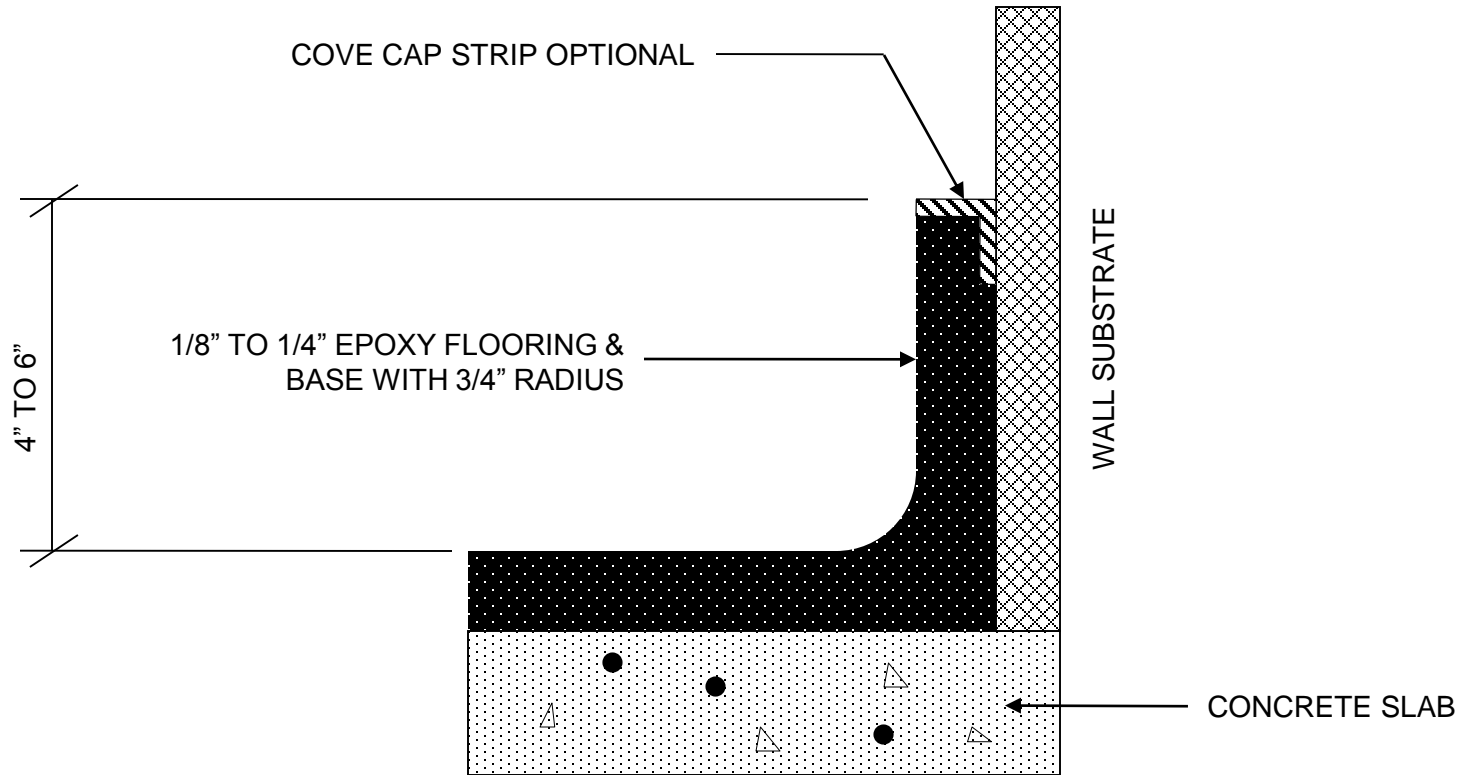

4050 Clough Woods Drive  
Batavia, Ohio 45103  
888-943-4532  
[www.keyresin.com](http://www.keyresin.com)

NOT TO  
SCALE

DATE:  
1/7/11

DETAIL: **COVE DETAIL #3 – RESINOUS FLOOR**

FILE #: **KEY-DTL-14**

Click For Table of Contents

## SAW CUT CONTROL JOINT RESINOUS FLOOR

FILL SAW CUT JOINT WITH  
KEY #780 FLEXIBLE EPOXY  
(OR APPROVED 100%  
SOLIDS FLEXIBLE EPOXY)

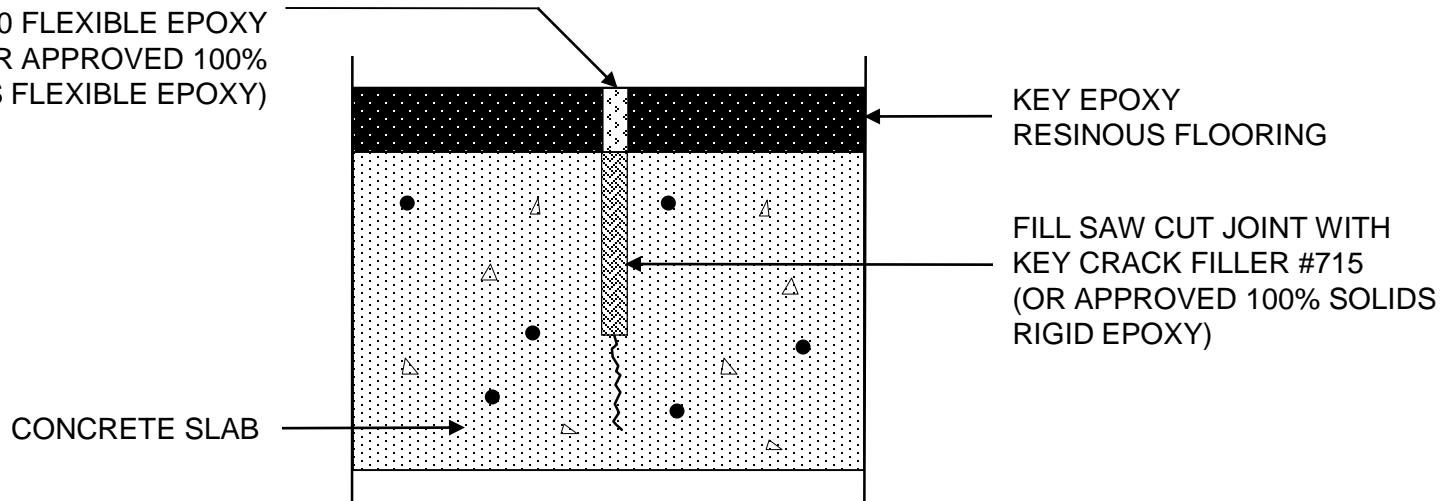

KEY EPOXY  
RESINOUS FLOORING

FILL SAW CUT JOINT WITH  
KEY CRACK FILLER #715  
(OR APPROVED 100% SOLIDS  
RIGID EPOXY)

CONCRETE SLAB

NOTE: FOLLOWING CURE OF INSTALLED  
RESINOUS FLOOR, SAW CUT TO RECEIVE  
FLEXIBLE EPOXY.



4050 Clough Woods Drive  
Batavia, Ohio 45103  
888-943-4532  
[www.keyresin.com](http://www.keyresin.com)

NOT TO  
SCALE

DATE:  
2/14/11

DETAIL: **JOINT DETAILS – RESINOUS FLOOR**

FILE #: **KEY-DTL-15**

Click For Table of Contents

PRECAST TERRAZZO TRESHOLD:  
1/2" HIGH WITH 45° CHAMFERED CORNERS

ANY TYPE OF  
FLOORING MATERIAL

3/8" KEY EPOXY  
TERRAZZO

STANDARD  
DIVIDER STRIP

1/16" THICK  
SETTING BED

STRUCT. SLAB

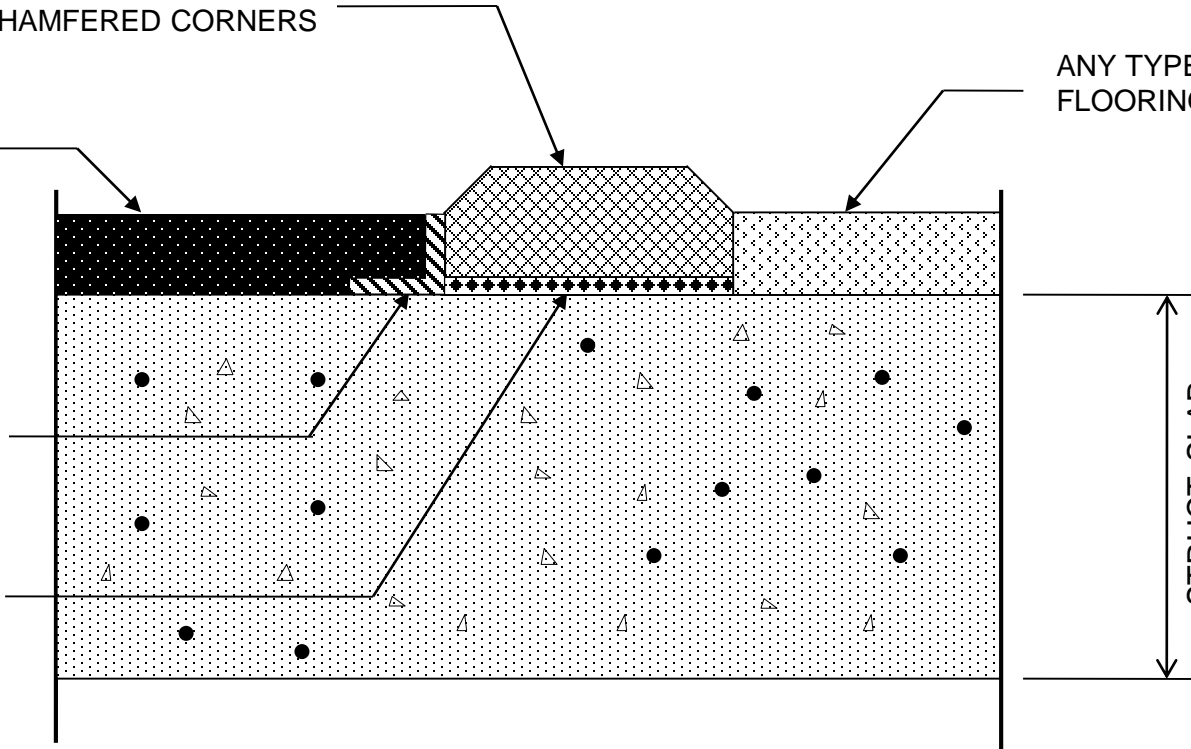

NOTE: DIVIDER STRIP AND PRECAST THRESHOLD  
ADHERED TO SUBSTRATE WITH 100% SOLIDS  
EPOXY ADHESIVE.



4050 Clough Woods Drive  
Batavia, Ohio 45103  
888-943-4532  
[www.keyresin.com](http://www.keyresin.com)

NOT TO  
SCALE

DATE:  
07/22/11

DETAIL: **PRECAST TERRAZZO THRESHOLD**

FILE #: **KEY-DTL-16**

*Click For Table of Contents*

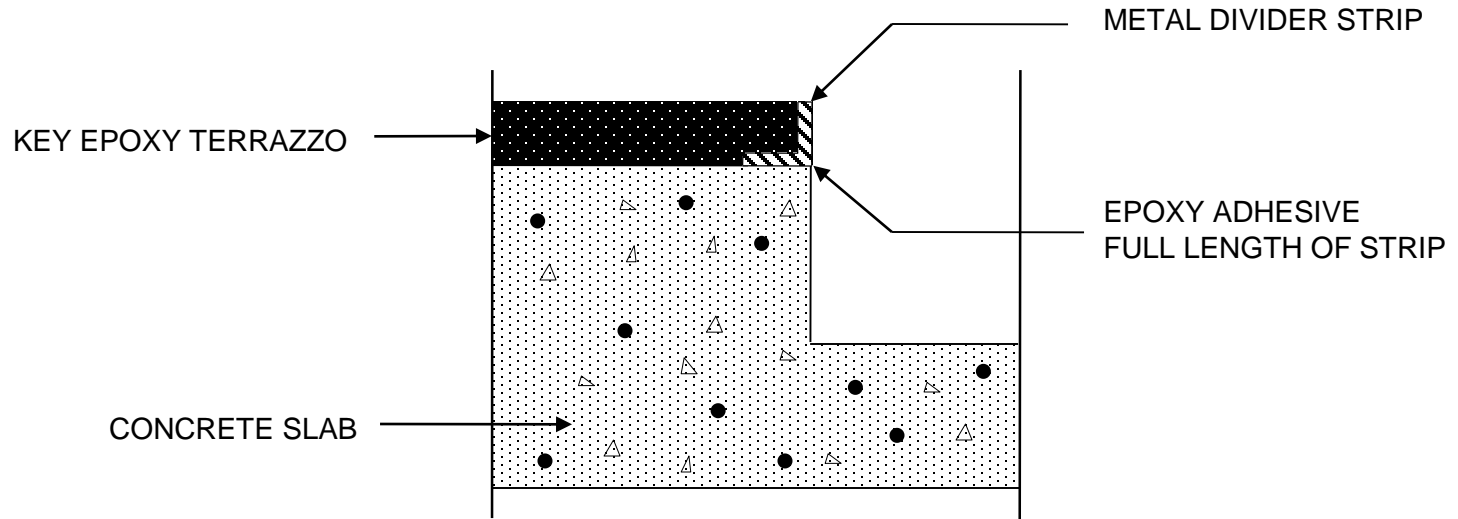

4050 Clough Woods Drive  
Batavia, Ohio 45103  
888-943-4532  
[www.keyresin.com](http://www.keyresin.com)

NOT TO  
SCALE

DATE:  
08/15/11

DETAIL: **TERRAZZO STEP TERMINATION DETAIL**

FILE #: **KEY-DTL-17**

*Click For Table of Contents*

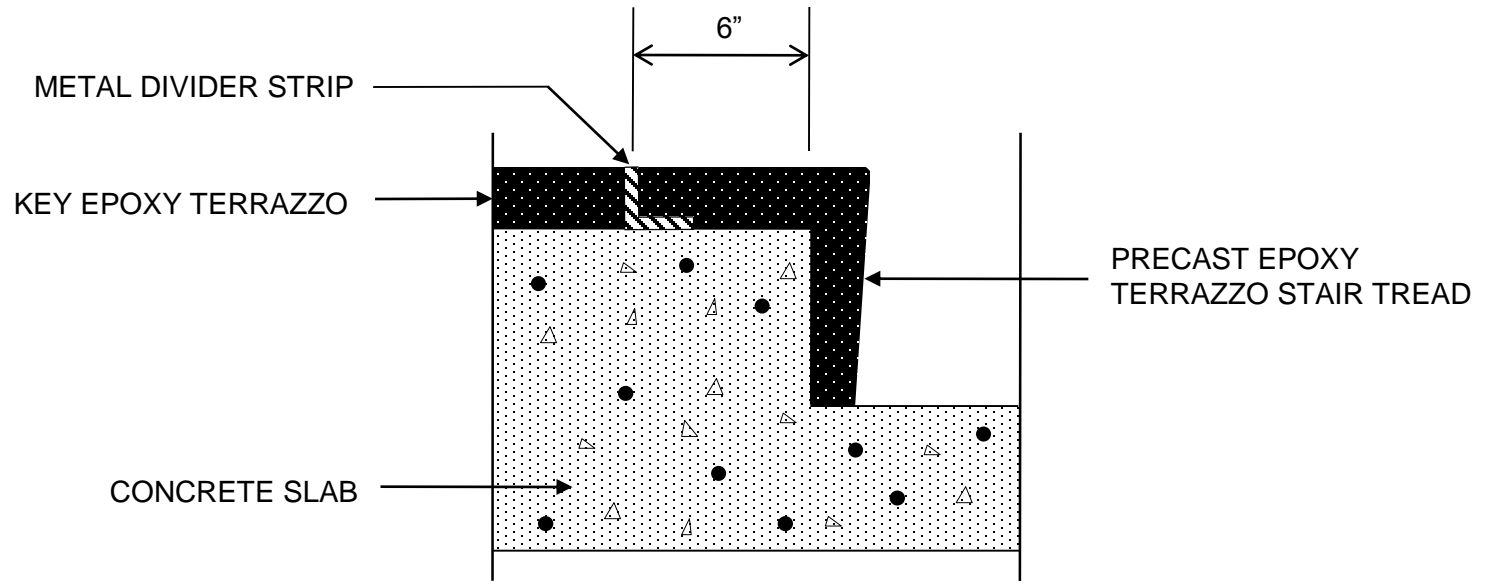

4050 Clough Woods Drive  
Batavia, Ohio 45103  
888-943-4532  
[www.keyresin.com](http://www.keyresin.com)

NOT TO  
SCALE

DATE:  
08/15/11

DETAIL:  
**RISER TREAD DETAIL**

FILE #:  
**KEY-DTL-18**

Click For Table of Contents

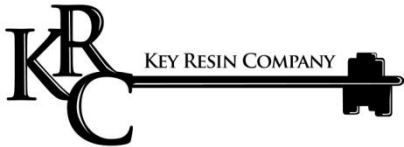
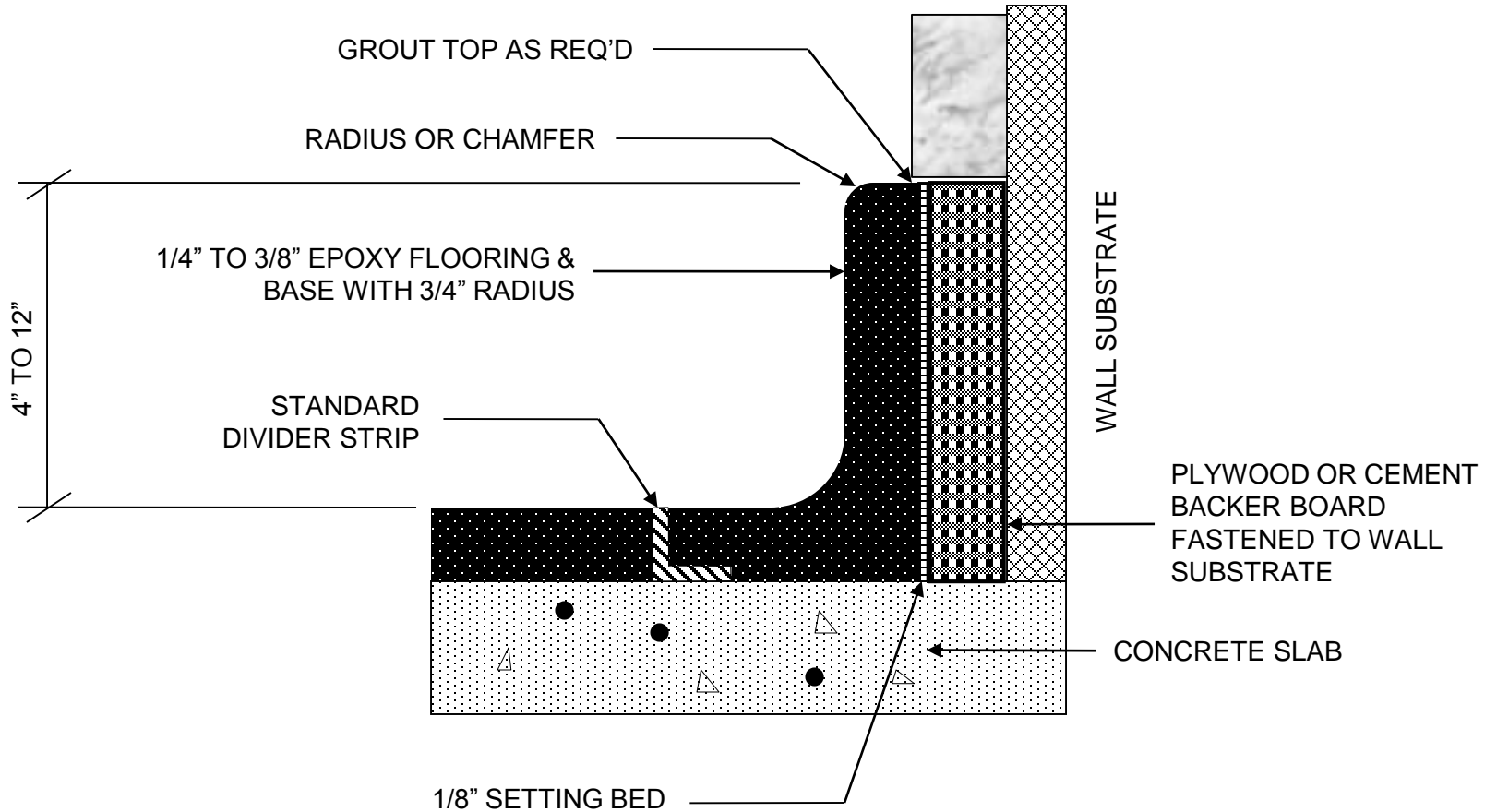

4050 Clough Woods Drive  
Batavia, Ohio 45103  
888-943-4532  
[www.keyresin.com](http://www.keyresin.com)

NOT TO SCALE

DATE:  
2/9/12

DETAIL: **PRECAST EPOXY TERRAZZO COVE BASE**

FILE #: **KEY-DTL-19**

Click For Table of Contents

# SAW CUT CONTROL JOINT RESINOUS FLOOR

1. SAW CUT TWO LINES TO CAPTURE ENTIRE WIDTH OF FLOOR CRACK AND REMOVE FLOORING IN BETWEEN
2. FILL SAW CUT JOINT WITH KEY #780 FLEXIBLE EPOXY (OR APPROVED 100% SOLIDS FLEXIBLE EPOXY)

1. SAW CUT TWO LINES TO CAPTURE ENTIRE WIDTH OF FLOOR CRACK AND REMOVE FLOORING IN BETWEEN
2. REPAIR SPACE WITH EXISTING FLOORING SYSTEM OR ALTERNATE COMPLIMENTARY SOLID COLOR EPOXY SYSTEM.

3. SAW CUT NARROW JOINT ABOVE FLOOR JOINT
4. FILL SAW CUT JOINT WITH KEY #780 FLEXIBLE EPOXY (OR APPROVED 100% SOLIDS FLEXIBLE EPOXY)

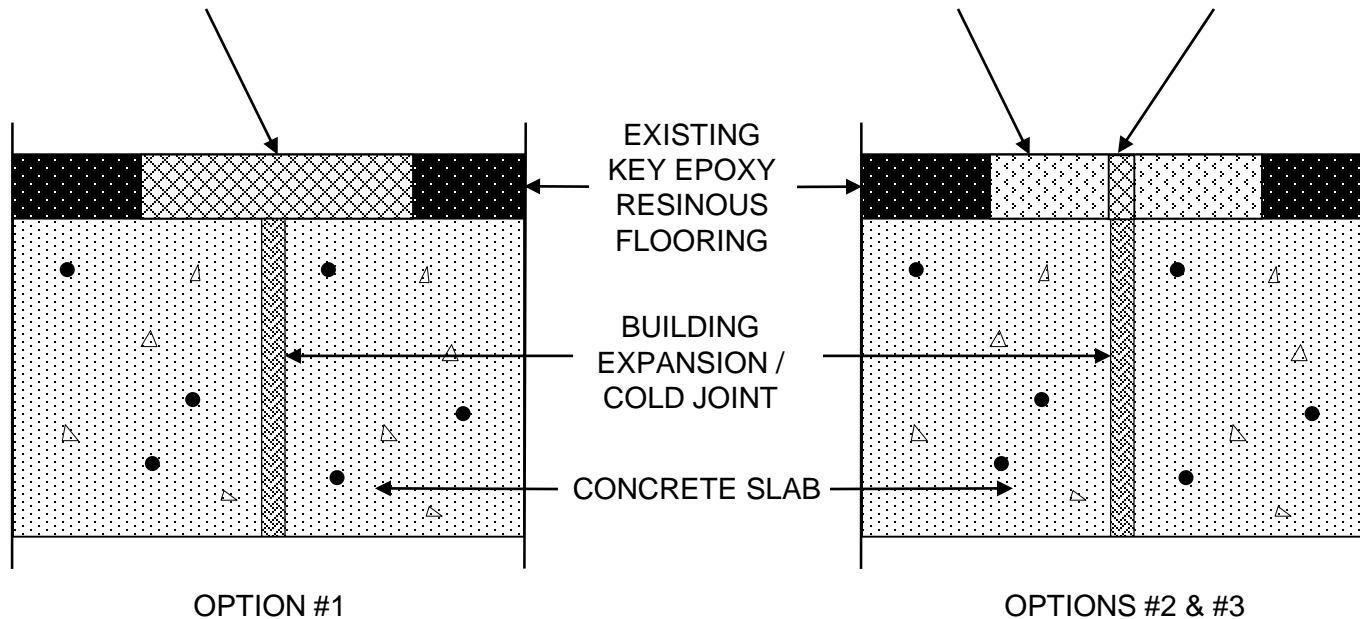

4050 Clough Woods Drive  
Batavia, Ohio 45103  
888-943-4532  
[www.keyresin.com](http://www.keyresin.com)

NOT TO  
SCALE

DATE:  
2/29/12

DETAIL: **JOINT DETAILS – RESINOUS FLOOR**

FILE #: **KEY-DTL-20**

*Click For Table of Contents*

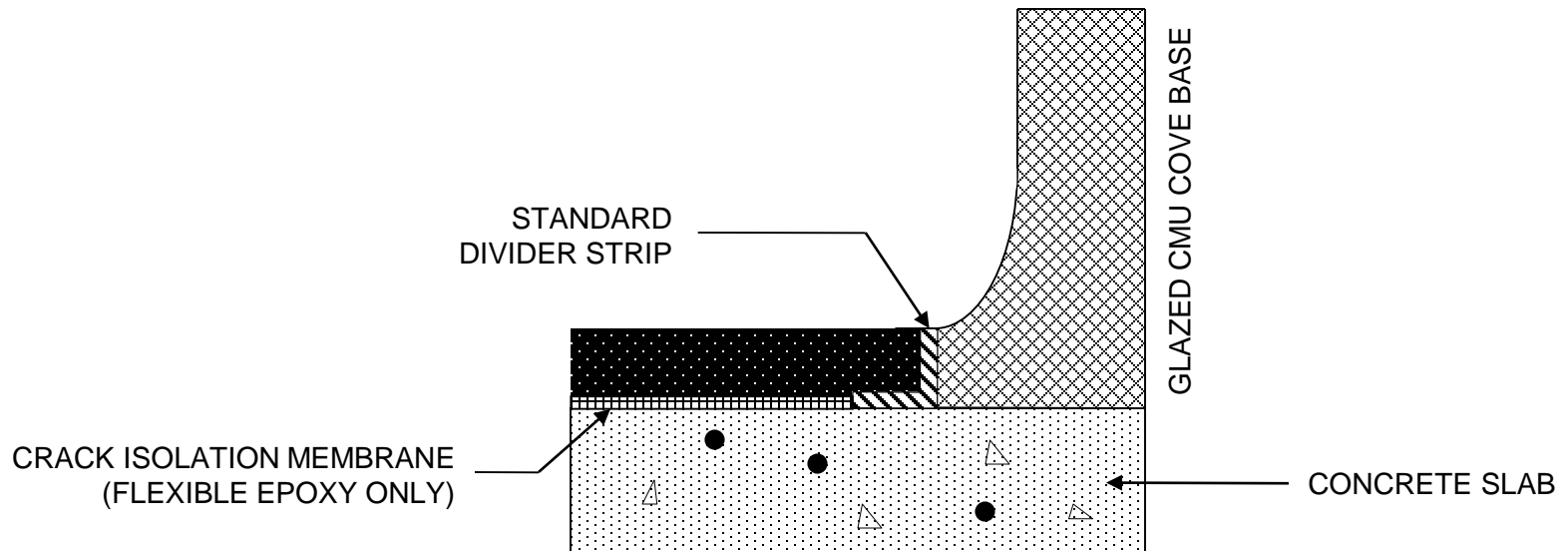

4050 Clough Woods Drive  
Batavia, Ohio 45103  
888-943-4532  
[www.keyresin.com](http://www.keyresin.com)

NOT TO  
SCALE

DATE:  
6/6/2012

DETAIL: **COVE DETAIL #4**

FILE #: **KEY-DTL-21**

*Click For Table of Contents*

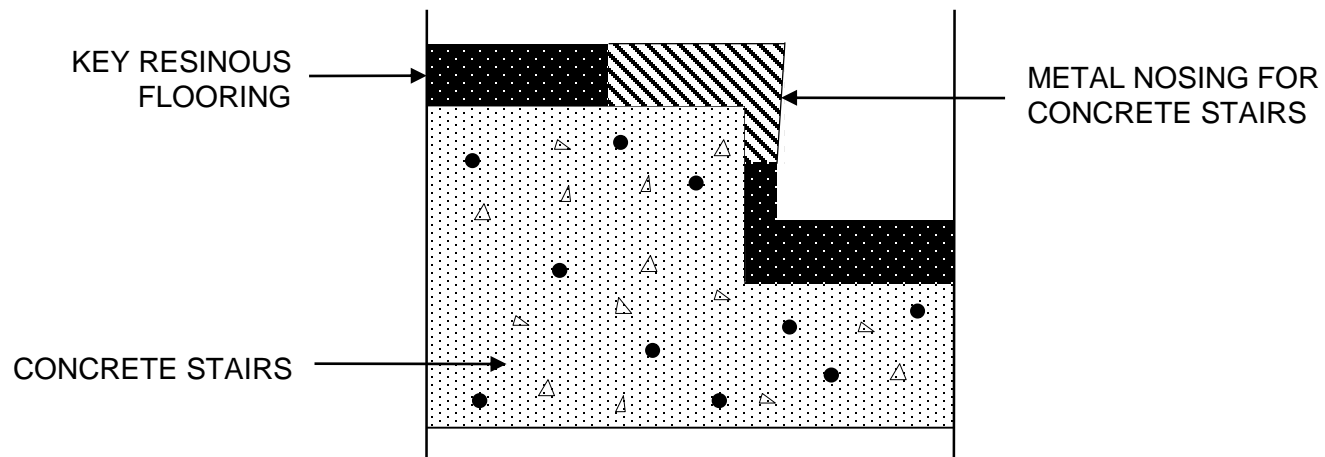

4050 Clough Woods Drive  
Batavia, Ohio 45103  
888-943-4532  
[www.keyresin.com](http://www.keyresin.com)

NOT TO  
SCALE  
DATE:  
**07/10/12**

DETAIL: **RESINOUS STAIR NOSING DETAIL**  
FILE #: **KEY-DTL-23**

*Click For Table of Contents*

FILL SAW CUT CHANNELS  
WITH SILICON CARBIDE OR  
ALUMINUM OXIDE IN 100%  
SOLIDS EPOXY RESIN

KEY RESINOUS  
FLOORING

CONCRETE STAIRS

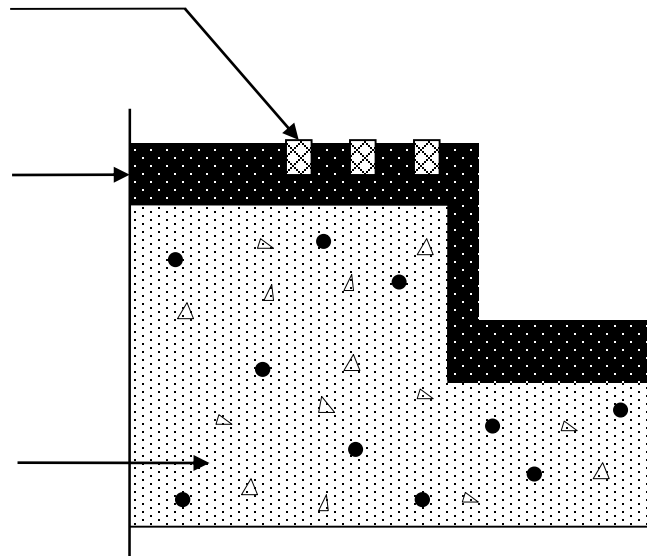

4050 Clough Woods Drive  
Batavia, Ohio 45103  
888-943-4532  
[www.keyresin.com](http://www.keyresin.com)

NOT TO  
SCALE

DATE:  
10/14/14

DETAIL:  
RISER TREAD DETAIL

FILE #:  
KEY-DTL-24

Click For Table of Contents

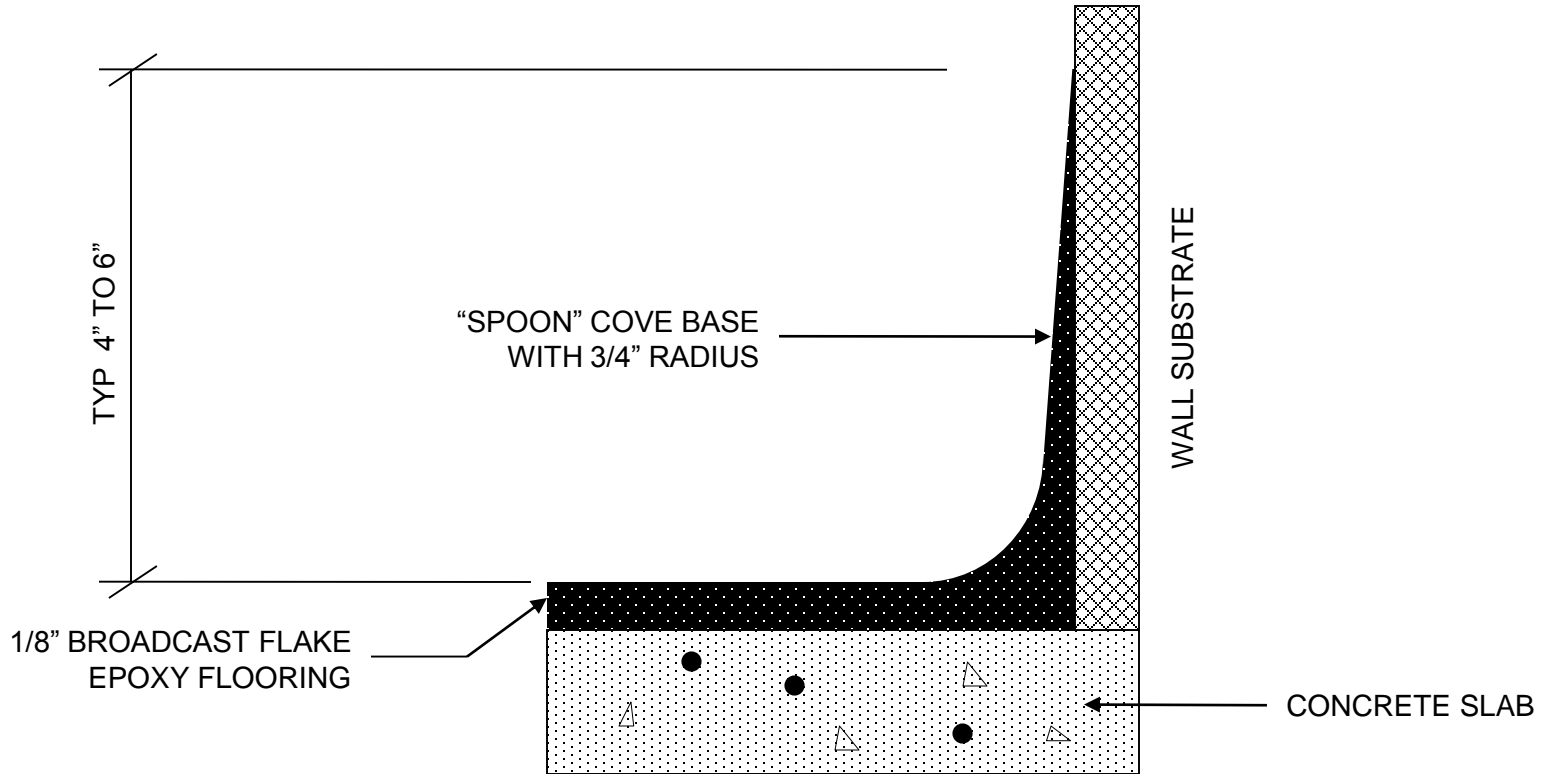

4050 Clough Woods Drive  
Batavia, Ohio 45103  
888-943-4532  
[www.keyresin.com](http://www.keyresin.com)

NOT TO  
SCALE  
DATE:  
01/02/13

DETAIL:  
**COVE DETAIL #5 – RESINOUS FLOOR**  
FILE #:  
**KEY-DTL-25**

Click For Table of Contents

# SAW CUT EXPANSION JOINT RESINOUS FLOOR

1. INSTALL KEY RESIN RESINOUS FLOORING
2. SAW CUT NARROW JOINT ABOVE FLOOR JOINT
3. FILL SAW CUT JOINT WITH KEY #780 FLEXIBLE EPOXY (OR APPROVED FLEXIBLE JOINT MATERIAL)

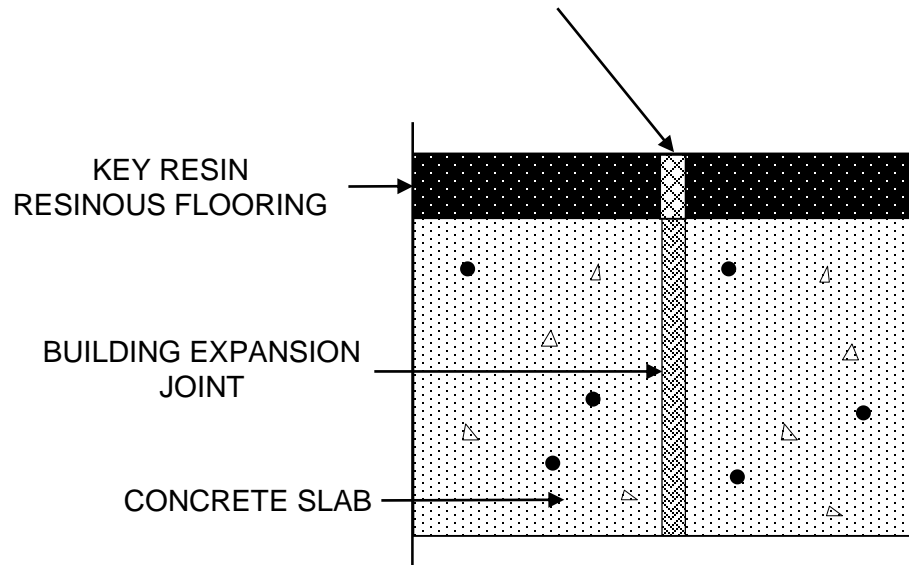

4050 Clough Woods Drive  
Batavia, Ohio 45103  
888-943-4532  
[www.keyresin.com](http://www.keyresin.com)

NOT TO  
SCALE

DATE:  
07/01/13

DETAIL: **SAW CUT EXPANSION JOINT – RS FLR**

FILE #: **KEY-DTL-26**

Click For Table of Contents

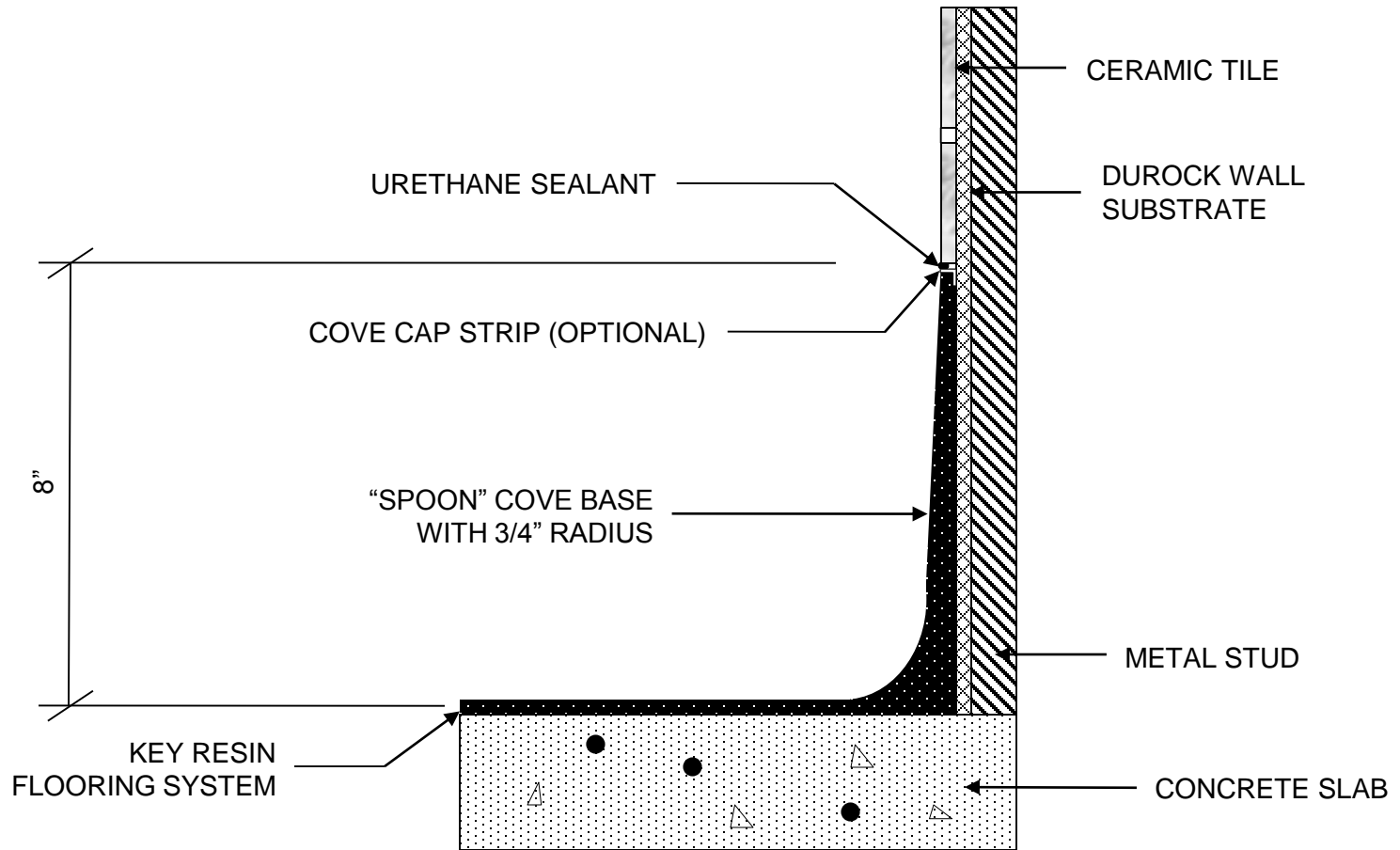

4050 Clough Woods Drive  
Batavia, Ohio 45103  
888-943-4532  
[www.keyresin.com](http://www.keyresin.com)

NOT TO  
SCALE

DATE:  
03/31/14

DETAIL: **COVE DETAIL #6 – 8" RESINOUS COVE**

FILE #: **KEY-DTL-27**

Click For Table of Contents

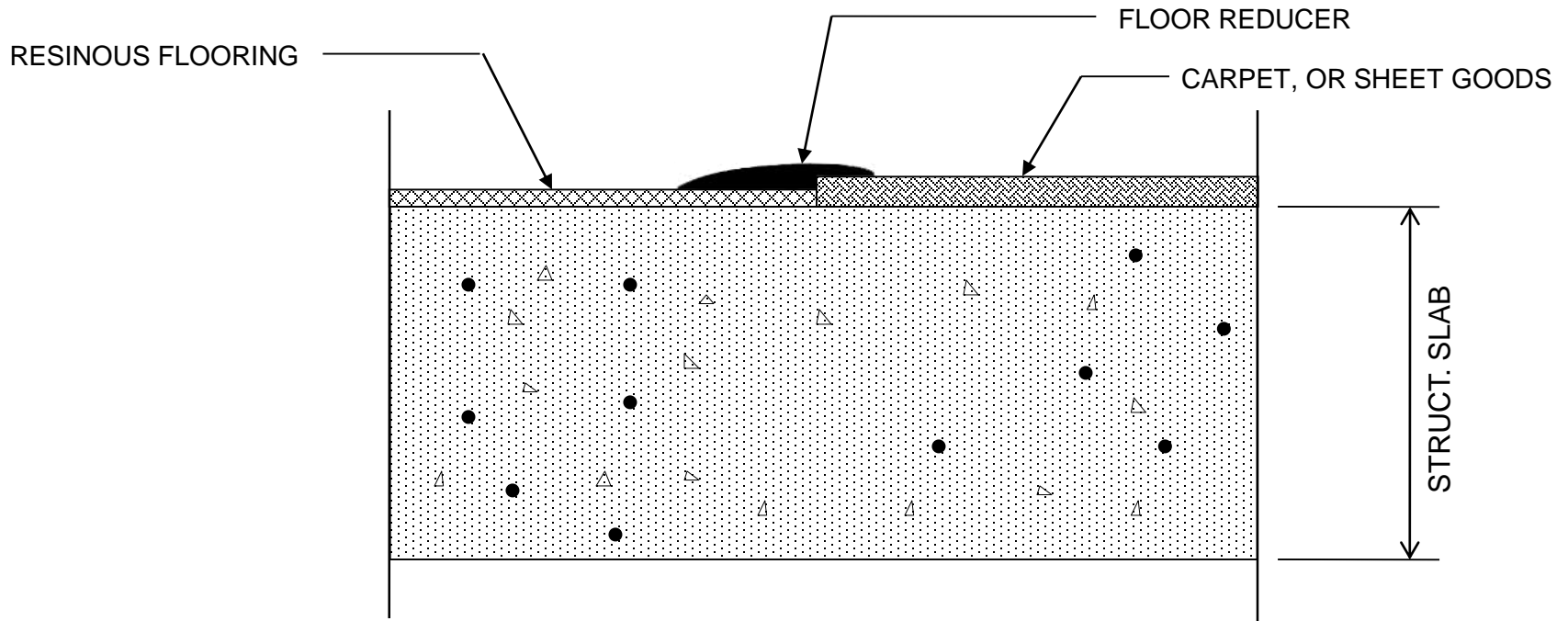

NOTE: RESINOUS FLOORING TO BE POURED FIRST.  
OTHER TRADES TO FINISH AT PROPER ELEVATION



4050 Clough Woods Drive  
Batavia, Ohio 45103  
888-943-4532  
[www.keyresin.com](http://www.keyresin.com)

NOT TO  
SCALE

DATE:  
04/18/14

DETAIL:  
RESINOUS FLOOR/CARPET TILE TERMINATION

FILE #:  
KEY-DTL-28

*Click For Table of Contents*

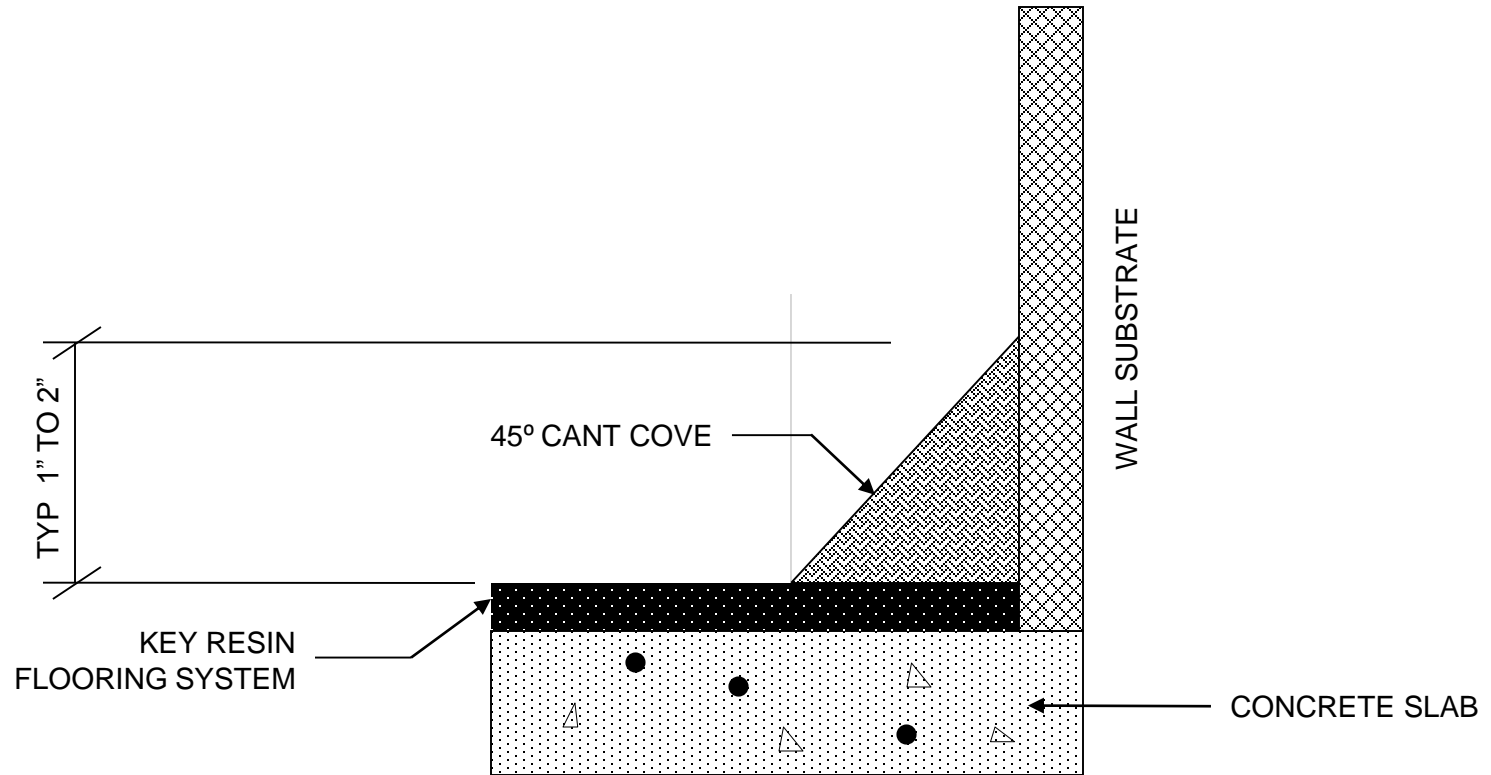

4050 Clough Woods Drive  
Batavia, Ohio 45103  
888-943-4532  
[www.keyresin.com](http://www.keyresin.com)

NOT TO  
SCALE  
DATE:  
04/18/14

DETAIL: **CANT COVE DETAIL – RESINOUS FLOOR**  
FILE #: **KEY-DTL-29**

Click For Table of Contents

NOTES:

- TYP POSITIONED 6" APART ACROSS A RAMP PERPENDICULAR TO THE TRAFFIC.
- TYP STOP 8" FROM THE WALL LINE.
- NON-SLIP LINE WIDTH IS NORMALLY 3/8" AND EACH STRIP IS ELEVATED ABOUT 1/16" ABOVE THE TERRAZZO SURFACE.
- COMMON INSTALLATION METHOD IS TO SAW CUT A GROOVE IN THE COMPLETED TERRAZZO 3/8" WIDE AND 1/4" DEEP AND FILL WITH AN EPOXY/ABRASIVE MIXTURE
- TYP ABRASIVES INCLUDE SILICON CARBIDE OR ALUMINUM OXIDE
- THE USE OF LIGHT-COLORED ABRASIVE STRIPS IS NOT RECOMMENDED DUE TO MAINTENANCE FACTORS

KEY RESIN EPOXY  
TERRAZZO SYSTEM

CONCRETE SUBSTRATE

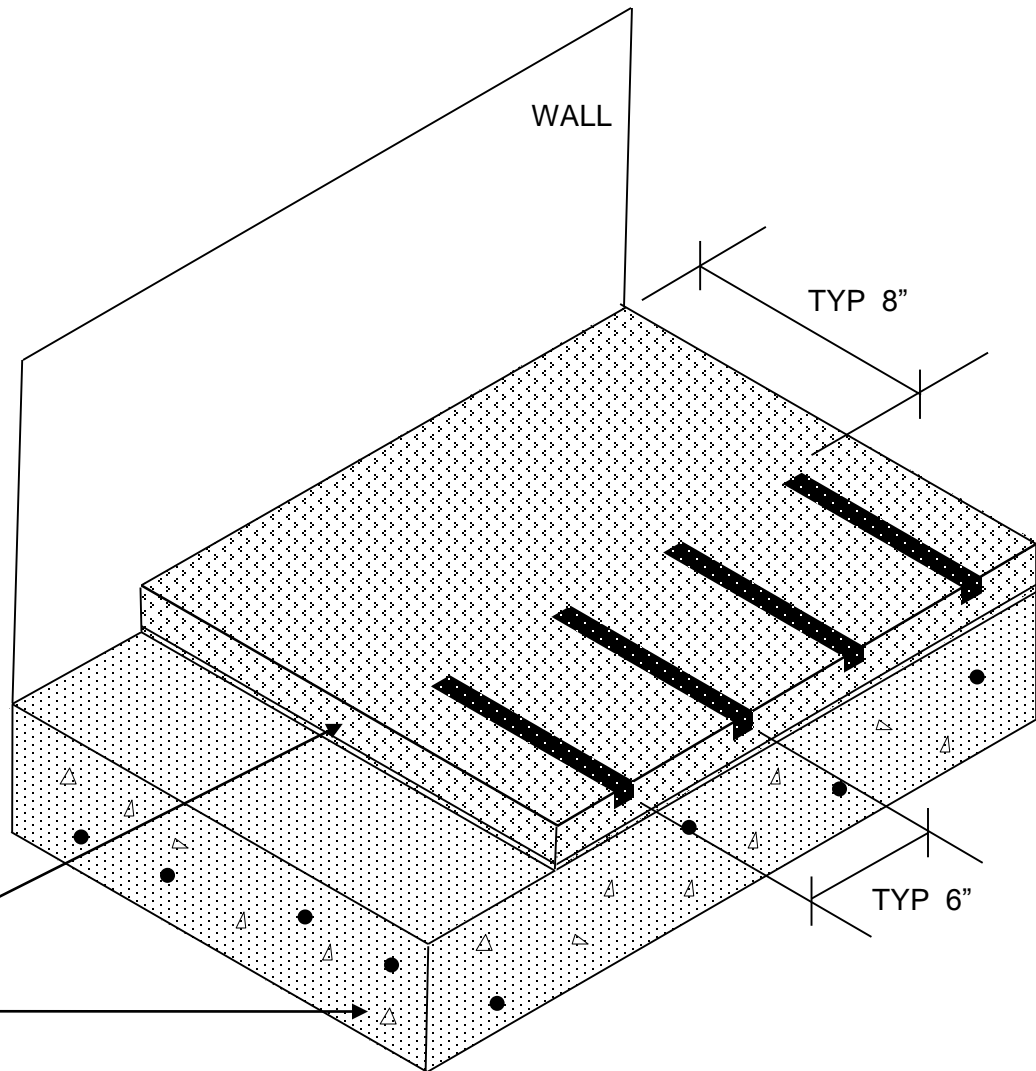

4050 Clough Woods Drive  
Batavia, Ohio 45103  
888-943-4532  
[www.keyresin.com](http://www.keyresin.com)

NOT TO  
SCALE

DATE:  
10/14/14

DETAIL: **ABRASIVE NON-SLIP LINES**

FILE #: **KEY-DTL-30**

Click For Table of Contents

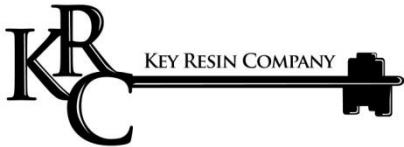
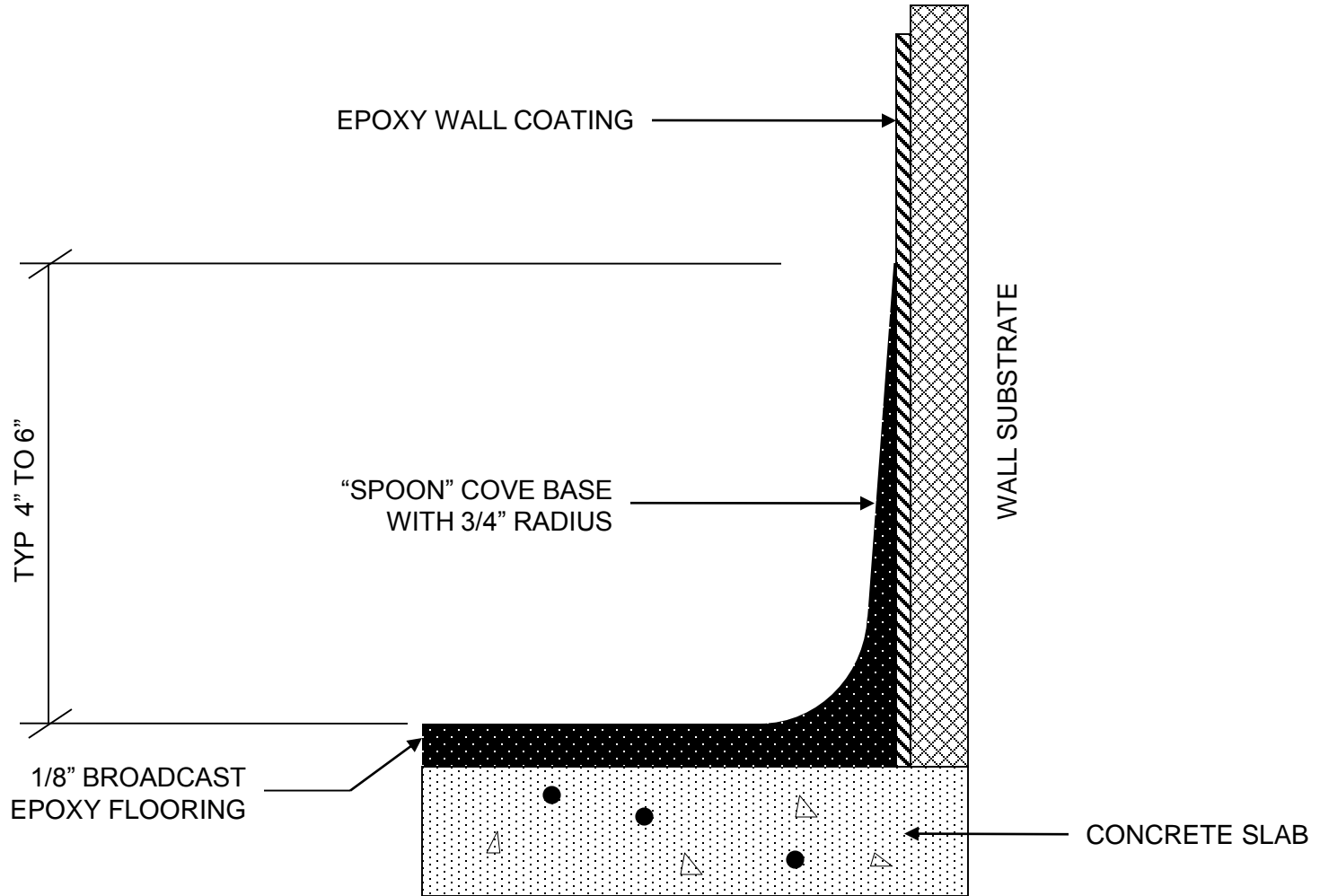

4050 Clough Woods Drive  
Batavia, Ohio 45103  
888-943-4532  
[www.keyresin.com](http://www.keyresin.com)

NOT TO  
SCALE  
DATE:  
10/23/14

DETAIL: **COVE DETAIL – RESINOUS FLOOR/WALL**  
FILE #: **KEY-DTL-31**

*Click For Table of Contents*

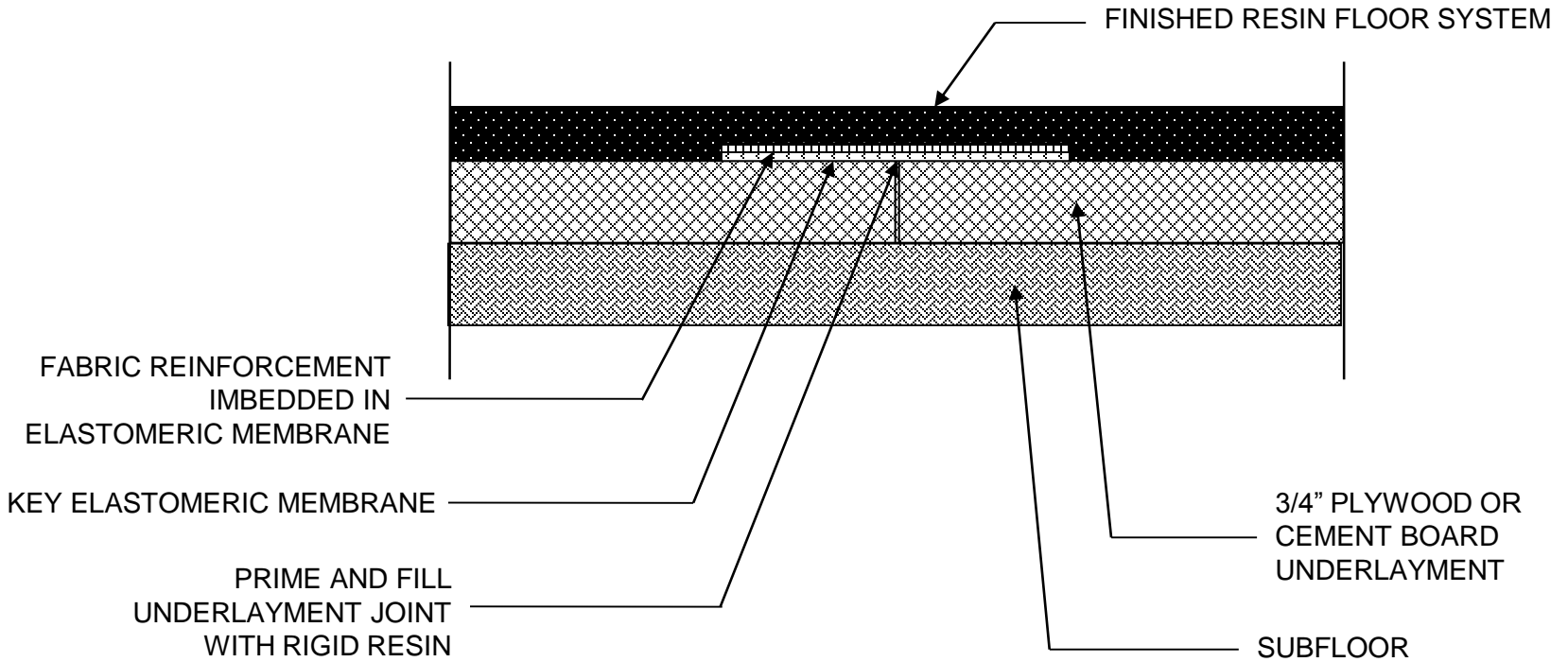

NOTE: REFER TO KEY RESIN TECHNICAL BULLETIN #1 FOR SELECTION OF WOOD SUBSTRATE MATERIALS

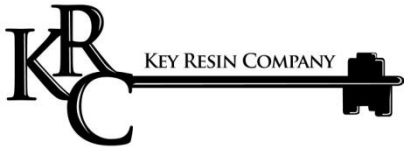

4050 Clough Woods Drive  
Batavia, Ohio 45103  
888-943-4532  
[www.keyresin.com](http://www.keyresin.com)

NOT TO SCALE

DATE:  
01/28/15

DETAIL: **JOINT TREATMENT – WOOD/CEMENT BOARD**

FILE #: **KEY-DTL-32**

*Click For Table of Contents*

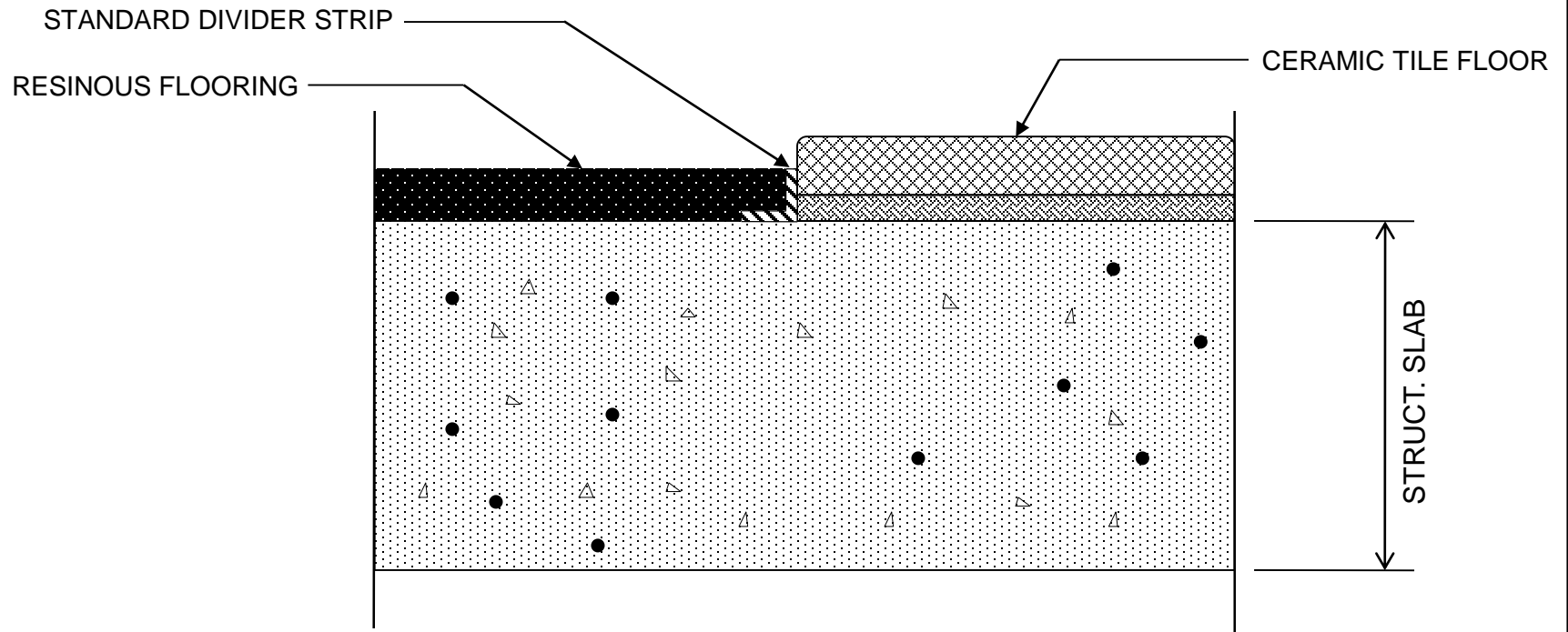

4050 Clough Woods Drive  
Batavia, Ohio 45103  
888-943-4532  
[www.keyresin.com](http://www.keyresin.com)

NOT TO  
SCALE

DATE:  
**03/20/15**

DETAIL:  
**RESINOUS FLR/CERAMIC TILE TERMINATION**

FILE #:  
**KEY-DTL-33**

*Click For Table of Contents*

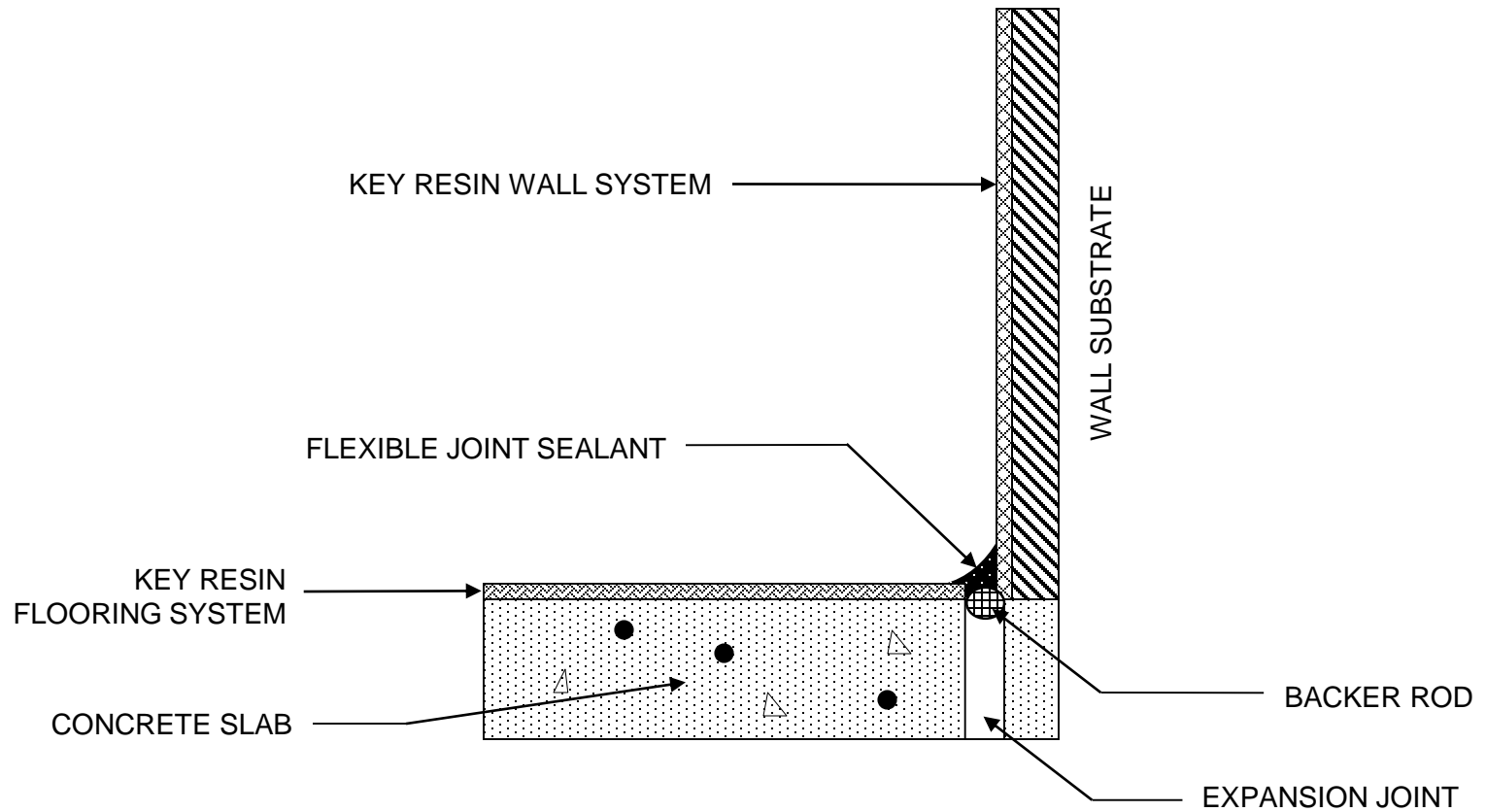

4050 Clough Woods Drive  
Batavia, Ohio 45103  
888-943-4532  
[www.keyresin.com](http://www.keyresin.com)

NOT TO  
SCALE

DATE:  
05/01/15

DETAIL:  
**COVE DETAIL #7 – OVER EXPANSION**

FILE #:  
**KEY-DTL-34**

Click For Table of Contents

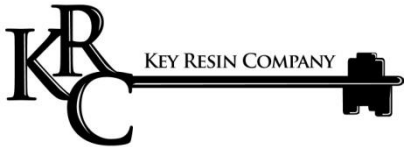
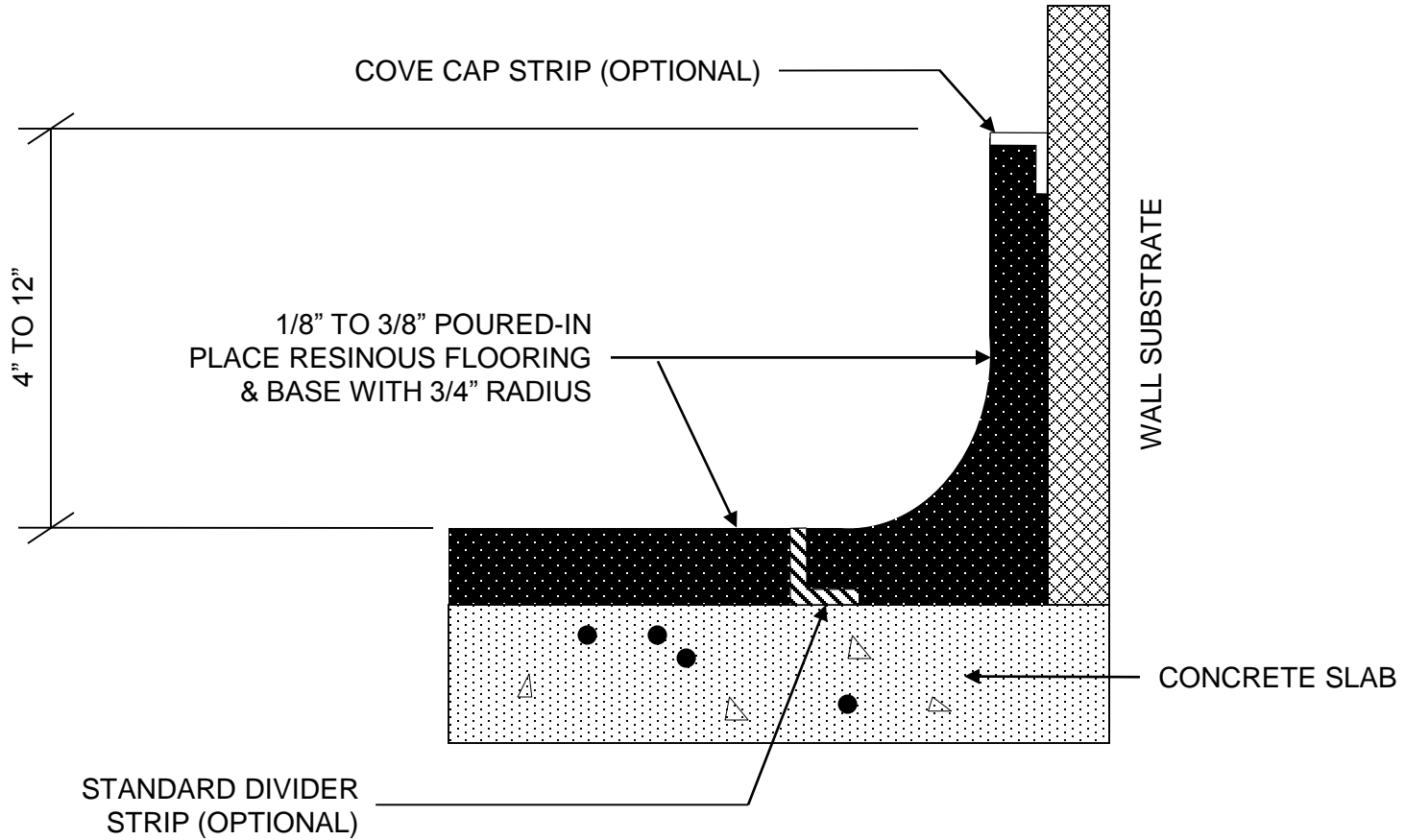

4050 Clough Woods Drive  
Batavia, Ohio 45103  
888-943-4532  
[www.keyresin.com](http://www.keyresin.com)

NOT TO  
SCALE

DATE:  
05/04/15

DETAIL: **COVE DETAIL #8 – RESINOUS W/ STRIPS**

FILE #: **KEY-DTL-35**

*Click For Table of Contents*

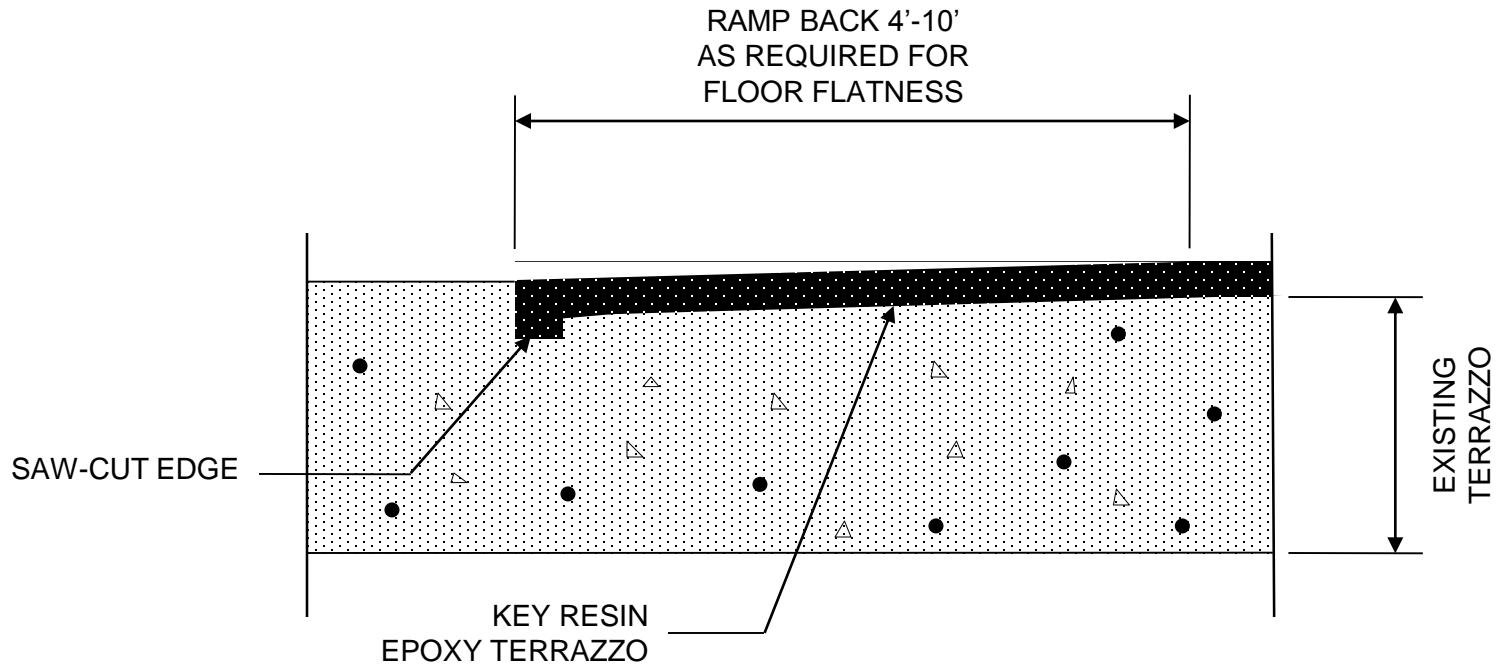

**NOTE:**

- SAW CUT TO CREATE A CLEAN TRANSITION EDGE.
- GRIND, SCARIFY, OR CHIP OUT EXISTING MATERIAL TO ALLOW FOR FULL THICKNESS OF FINAL FLOOR TOPPING WITHOUT FEATHER EDGING.
- FOLLOW THE NTMA'S STANDARD RECOMMENDATIONS FOR INSTALLATION OVER EXISTING TERRAZZO.



4050 Clough Woods Drive  
Batavia, Ohio 45103  
888-943-4532  
[www.keyresin.com](http://www.keyresin.com)

**NOT TO  
SCALE**

DATE:  
**06/05/15**

DETAIL:  
**TERRAZZO OVERLAY TRANSITION**

FILE #:  
**KEY-DTL-36**

Click For Table of Contents

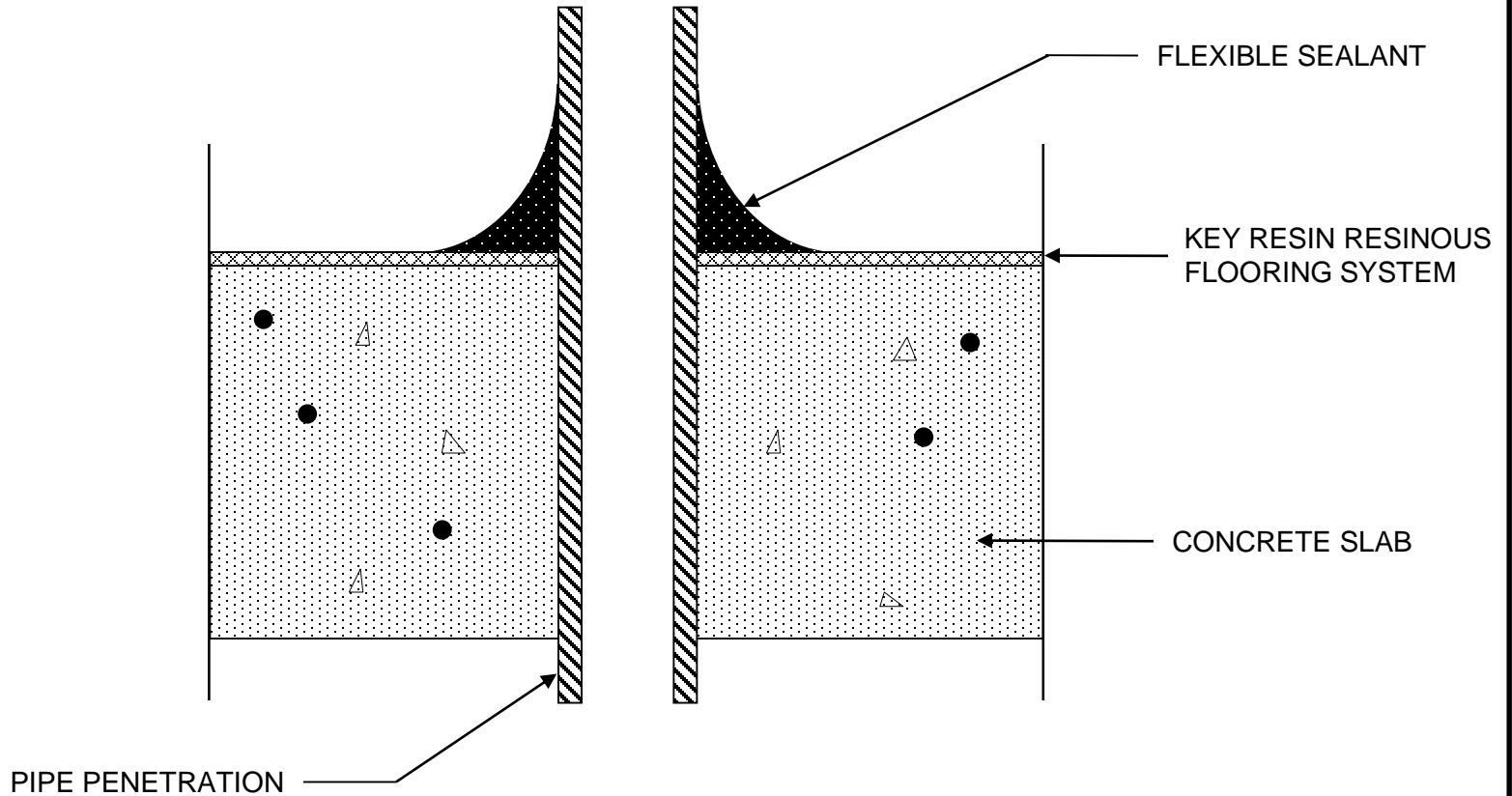

4050 Clough Woods Drive  
Batavia, Ohio 45103  
888-943-4532  
[www.keyresin.com](http://www.keyresin.com)

NOT TO  
SCALE

DATE:  
06/15/15

DETAIL:  
**PIPE PENETRATION DETAIL**

FILE #:  
**KEY-DTL-37**

Click For Table of Contents

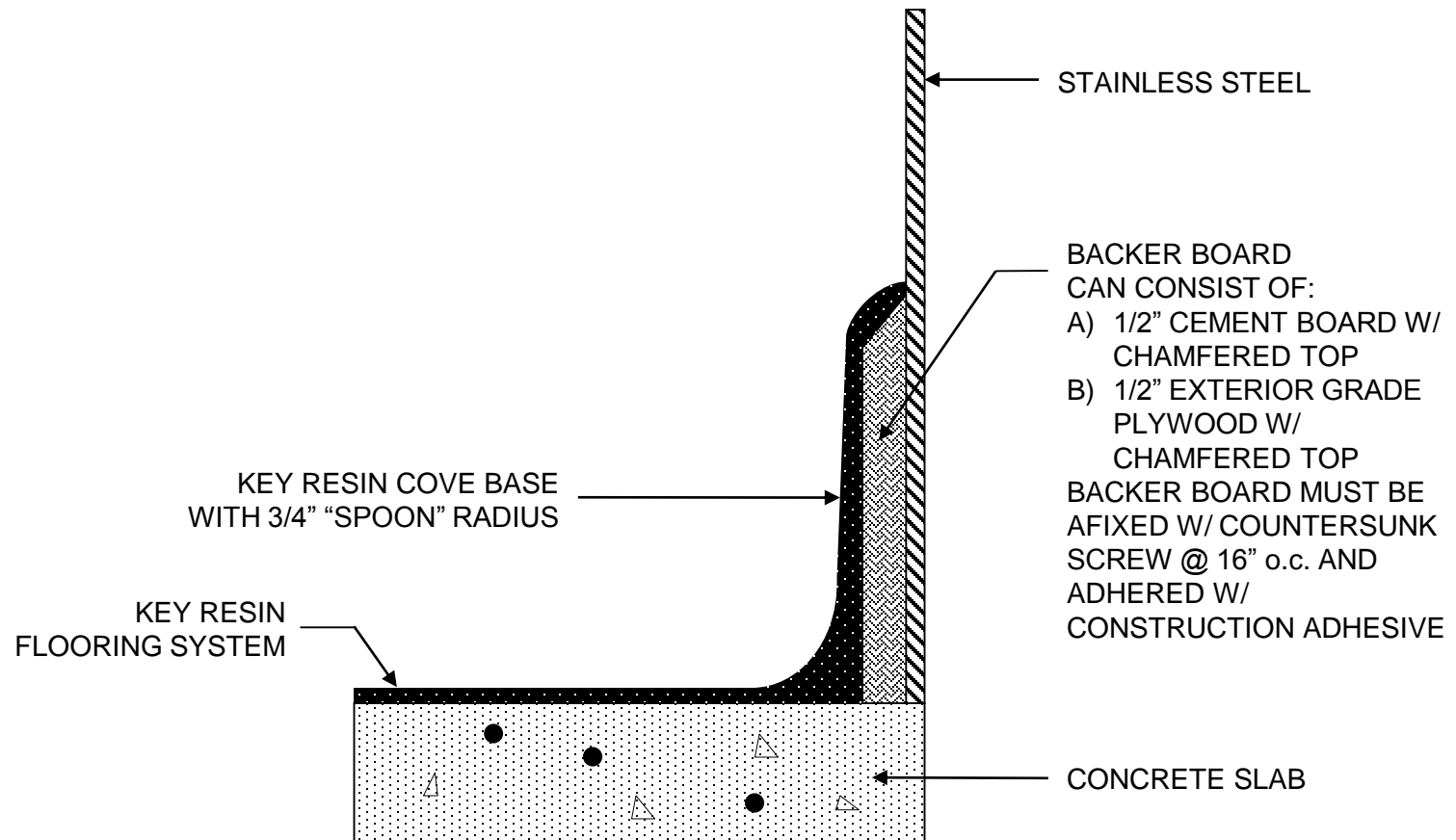

4050 Clough Woods Drive  
Batavia, Ohio 45103  
888-943-4532  
[www.keyresin.com](http://www.keyresin.com)

NOT TO  
SCALE  
DATE:  
06/23/15

DETAIL:  
**COVE BASE ON STAINLESS STEEL**  
FILE #:  
**KEY-DTL-38**

Click For Table of Contents

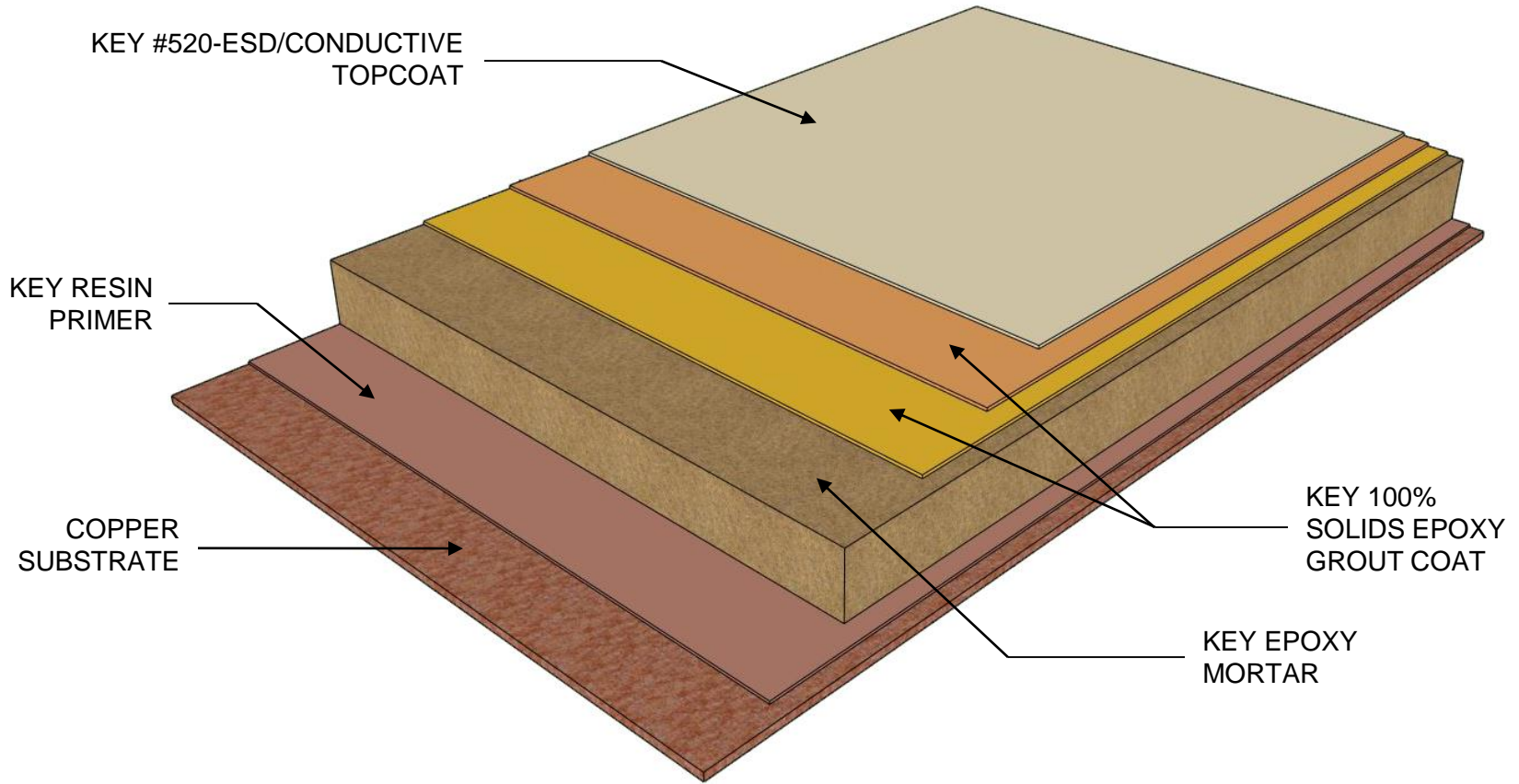

4050 Clough Woods Drive  
Batavia, Ohio 45103  
888-943-4532  
[www.keyresin.com](http://www.keyresin.com)

NOT TO  
SCALE  
DATE:  
11/13/15

DETAIL: **TYPICAL MRI SUITE FLOORING DETAIL**  
FILE #: **KEY-DTL-39**

Click For Table of Contents

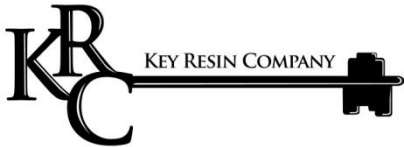
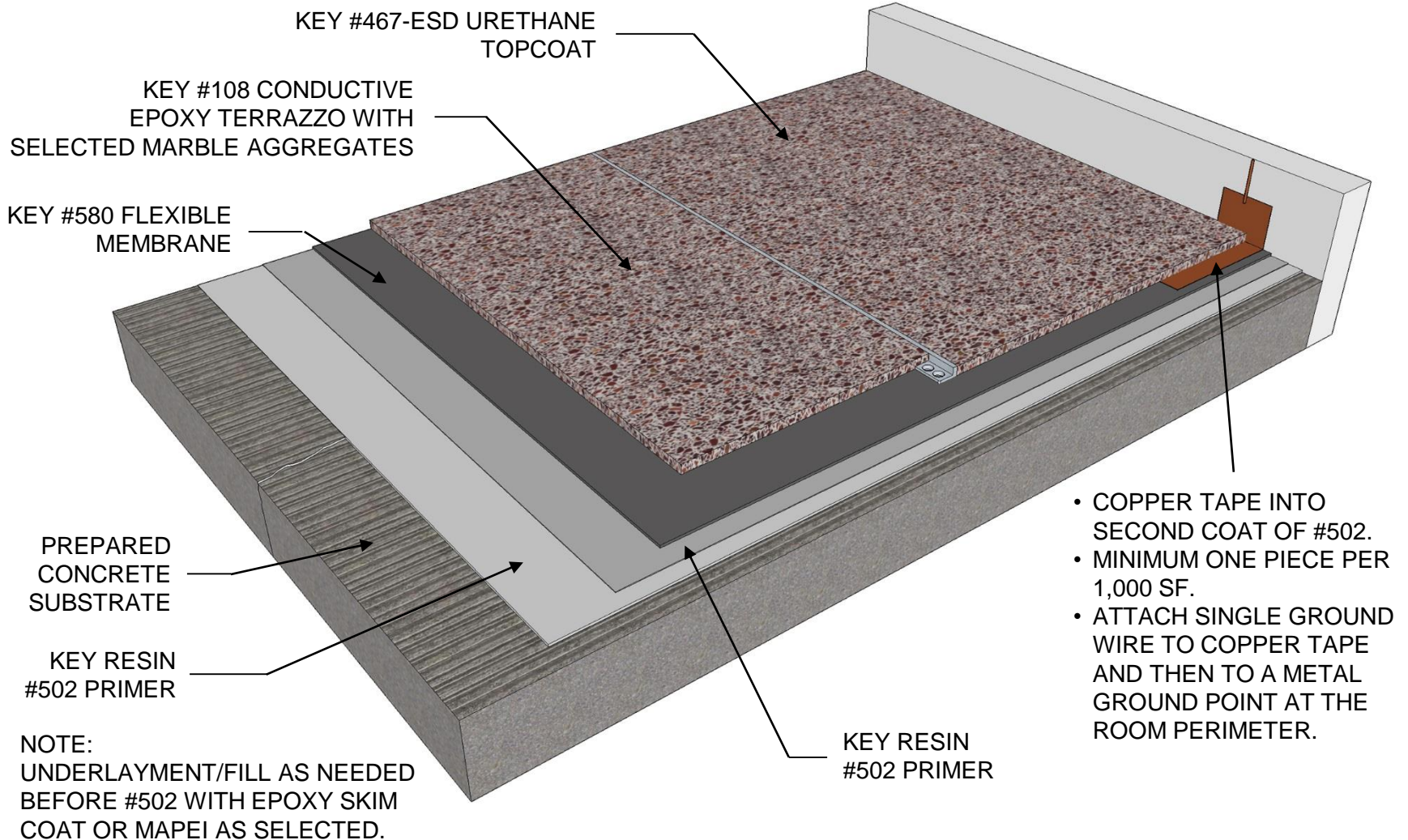

4050 Clough Woods Drive  
Batavia, Ohio 45103  
888-943-4532  
[www.keyresin.com](http://www.keyresin.com)

NOT TO SCALE  
DATE: 12/11/15

Click For Table of Contents

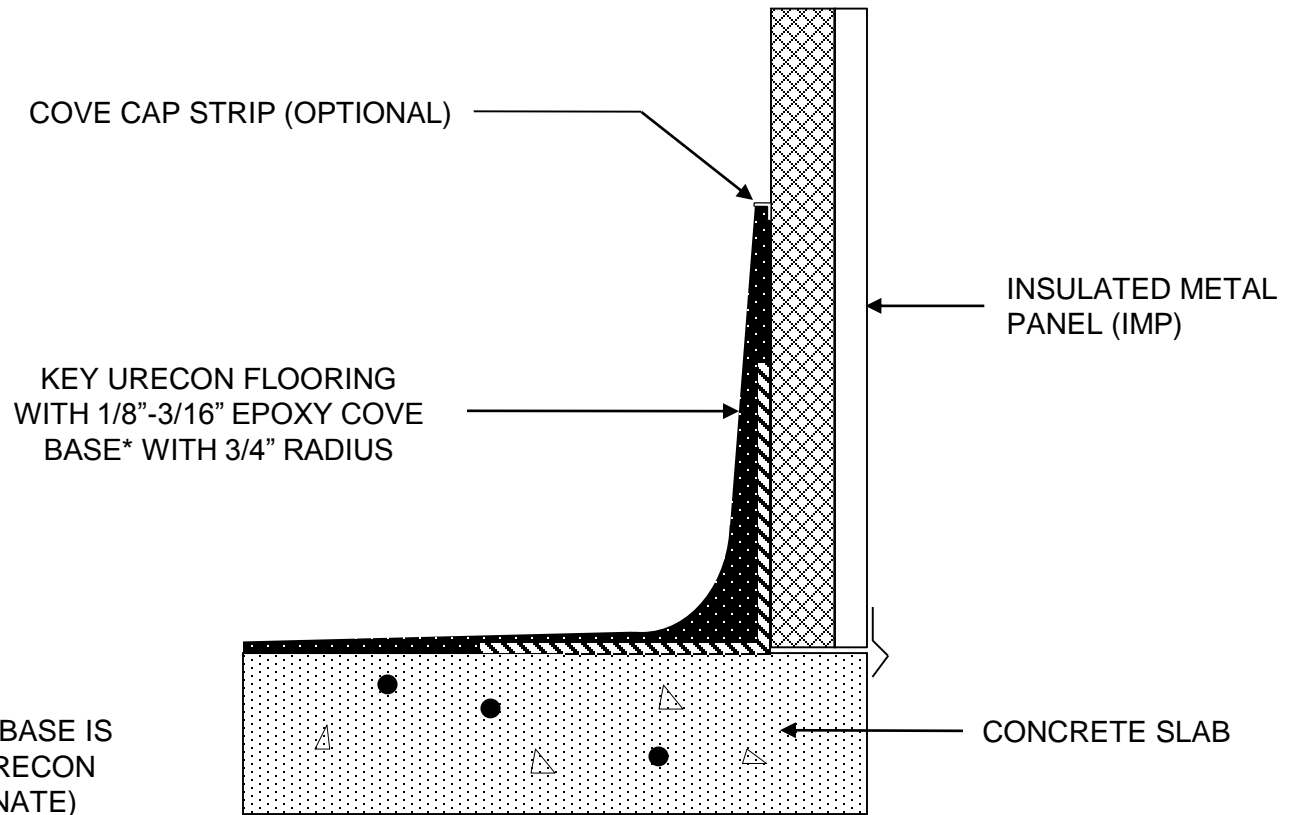

4050 Clough Woods Drive  
Batavia, Ohio 45103  
888-943-4532  
[www.keyresin.com](http://www.keyresin.com)

NOT TO  
SCALE

DATE:  
12/14/15

DETAIL: **COVE DETAIL #9 – INTEGRAL WITH IMP**

FILE #: **KEY-DTL-42**

*Click For Table of Contents*

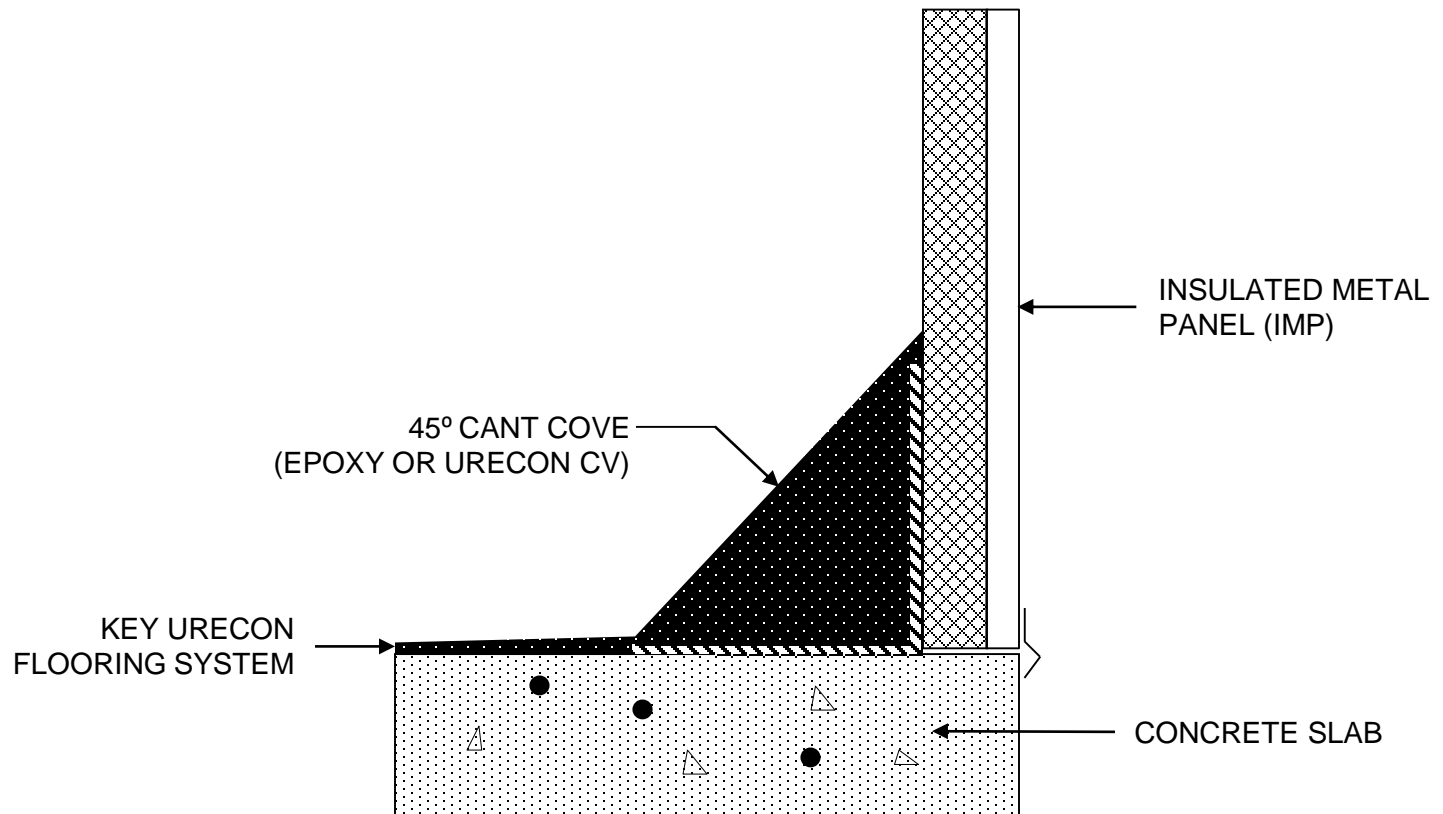

4050 Clough Woods Drive  
Batavia, Ohio 45103  
888-943-4532  
[www.keyresin.com](http://www.keyresin.com)

NOT TO  
SCALE

DATE:  
12/14/15

DETAIL: **COVE DETAIL #10 – CANT WITH IMP**

FILE #: **KEY-DTL-42**

*Click For Table of Contents*

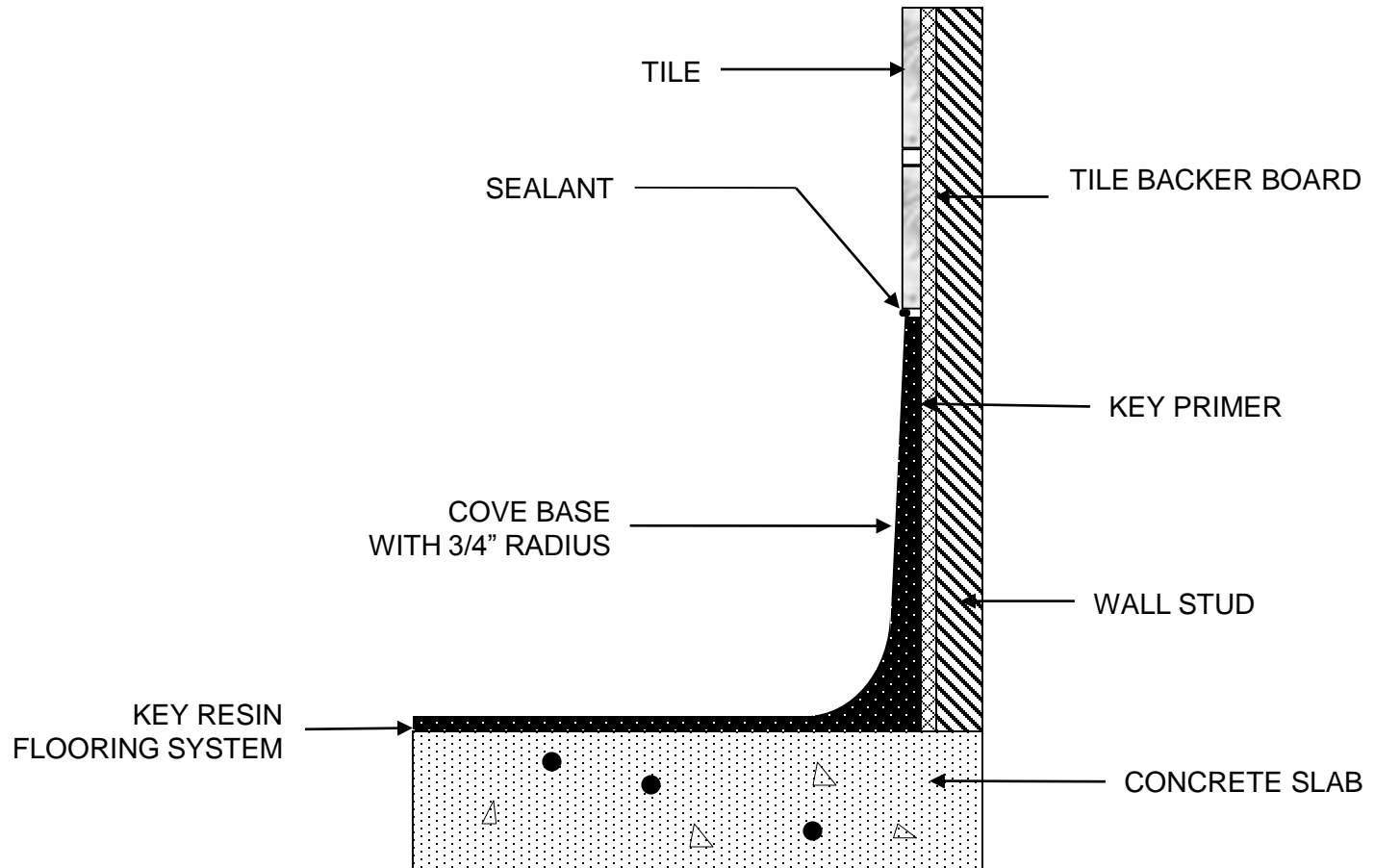

4050 Clough Woods Drive  
Batavia, Ohio 45103  
888-943-4532  
[www.keyresin.com](http://www.keyresin.com)

NOT TO  
SCALE

DATE:  
02/02/16

DETAIL:  
**COVE DETAIL #11 – TILE WALL #1**

FILE #:  
**KEY-DTL-43**

Click For Table of Contents

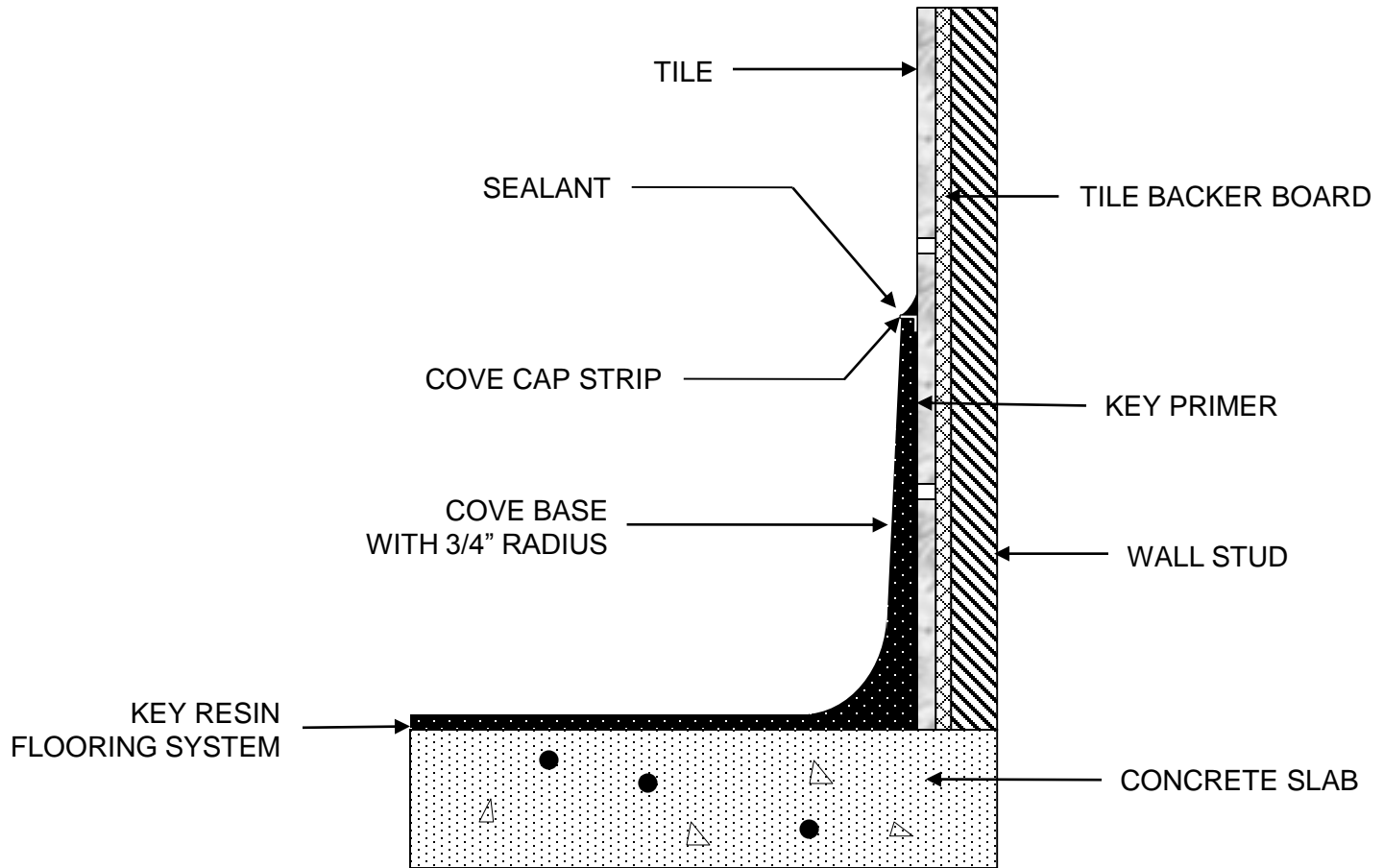

NOTE:  
TILE TO RECEIVE COVE BASE MUST BE  
AGGRESSIVELY PREPARED TO REMOVE ALL GLOSS



4050 Clough Woods Drive  
Batavia, Ohio 45103  
888-943-4532  
[www.keyresin.com](http://www.keyresin.com)

NOT TO  
SCALE

DATE:  
02/02/16

DETAIL:  
**COVE DETAIL #12 – TILE WALL #2**

FILE #:  
**KEY-DTL-44**

Click For Table of Contents

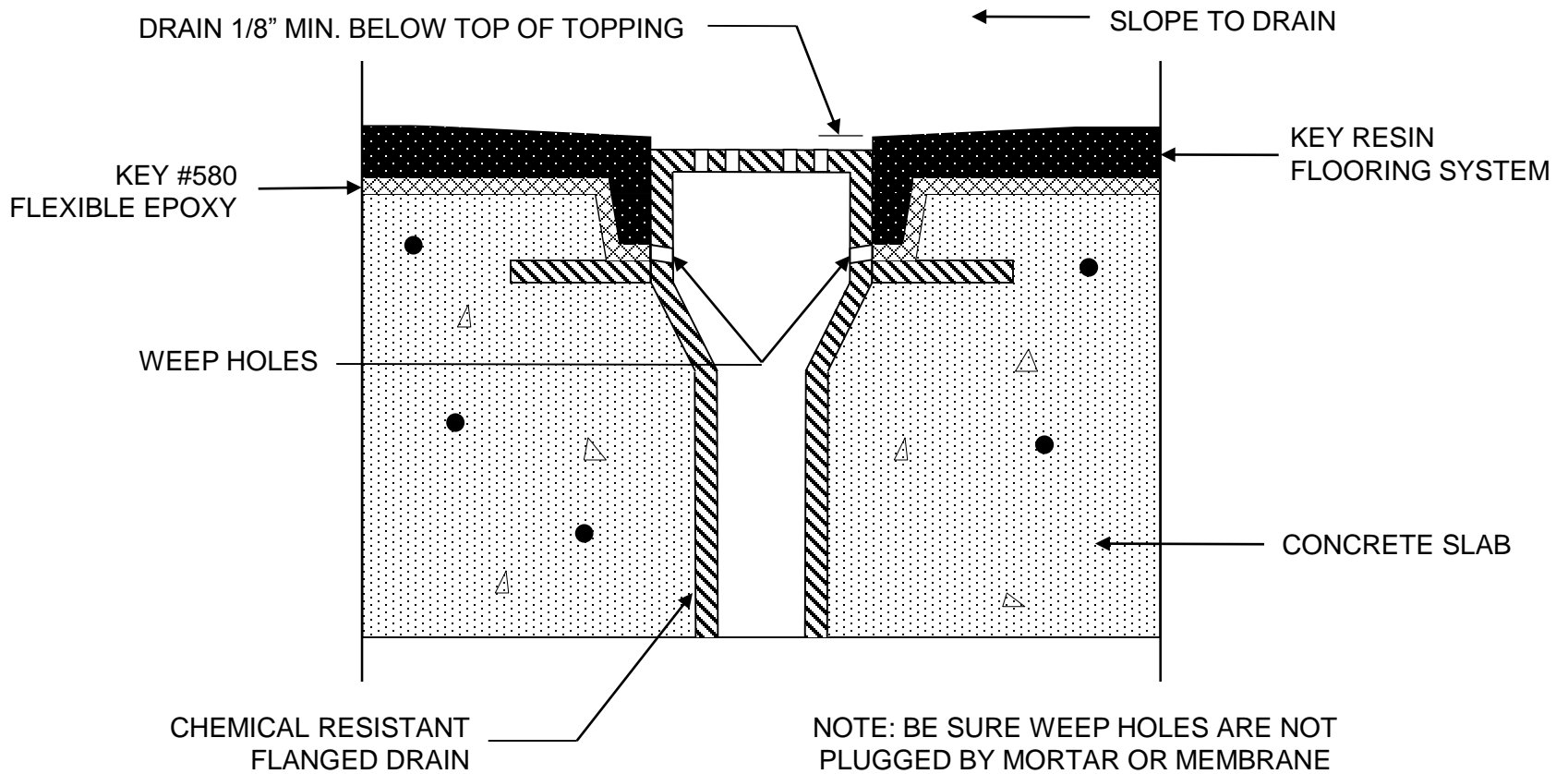

4050 Clough Woods Drive  
Batavia, Ohio 45103  
888-943-4532  
[www.keyresin.com](http://www.keyresin.com)

NOT TO  
SCALE

DATE:  
2/26/16

DETAIL:  
**FLANGED DRAIN WATERPROOFING**

FILE #:  
**KEY-DTL-45**

Click For Table of Contents

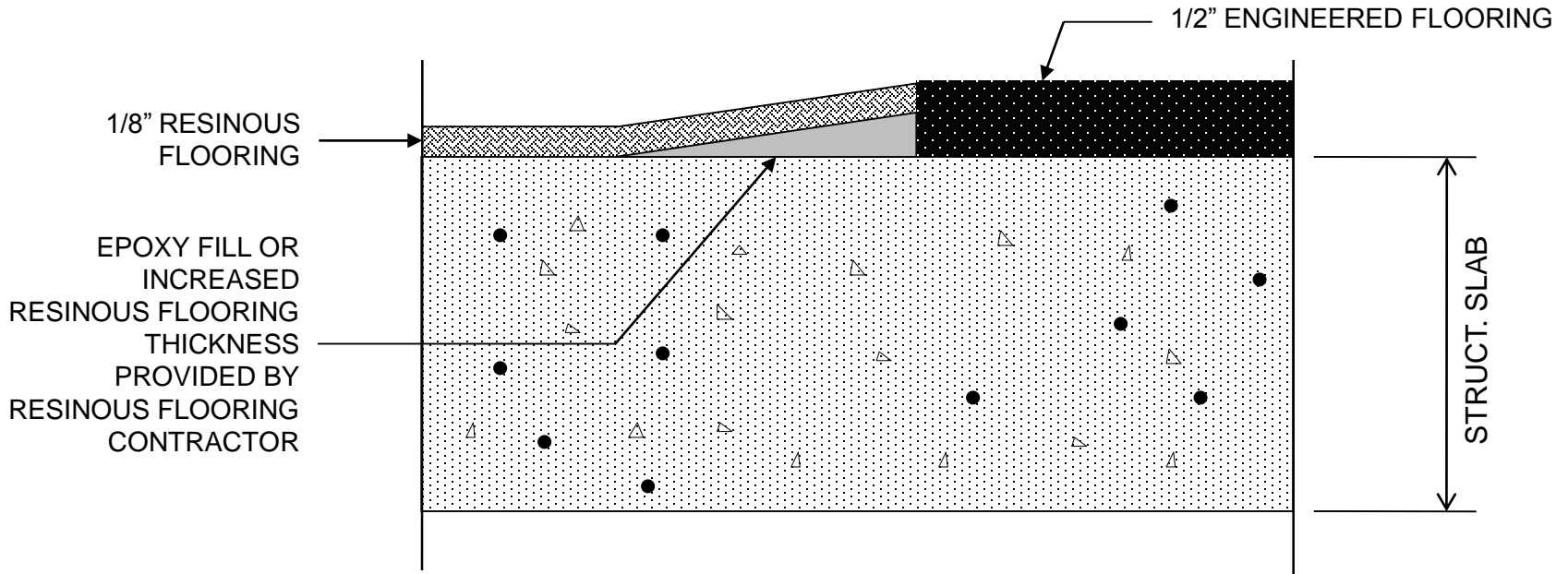

NOTE: ENGINEERED FLOORING TO BE INSTALLED FIRST.  
RESINOUS FLOORING TO FINISH AT PROPER ELEVATION.

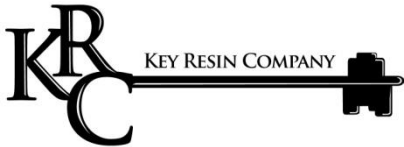

4050 Clough Woods Drive  
Batavia, Ohio 45103  
888-943-4532  
[www.keyresin.com](http://www.keyresin.com)

NOT TO  
SCALE

DATE:  
03/09/16

DETAIL: **RESINOUS FLOORING TERMINATION**

FILE #: **KEY-DTL-46**

[Click For Table of Contents](#)

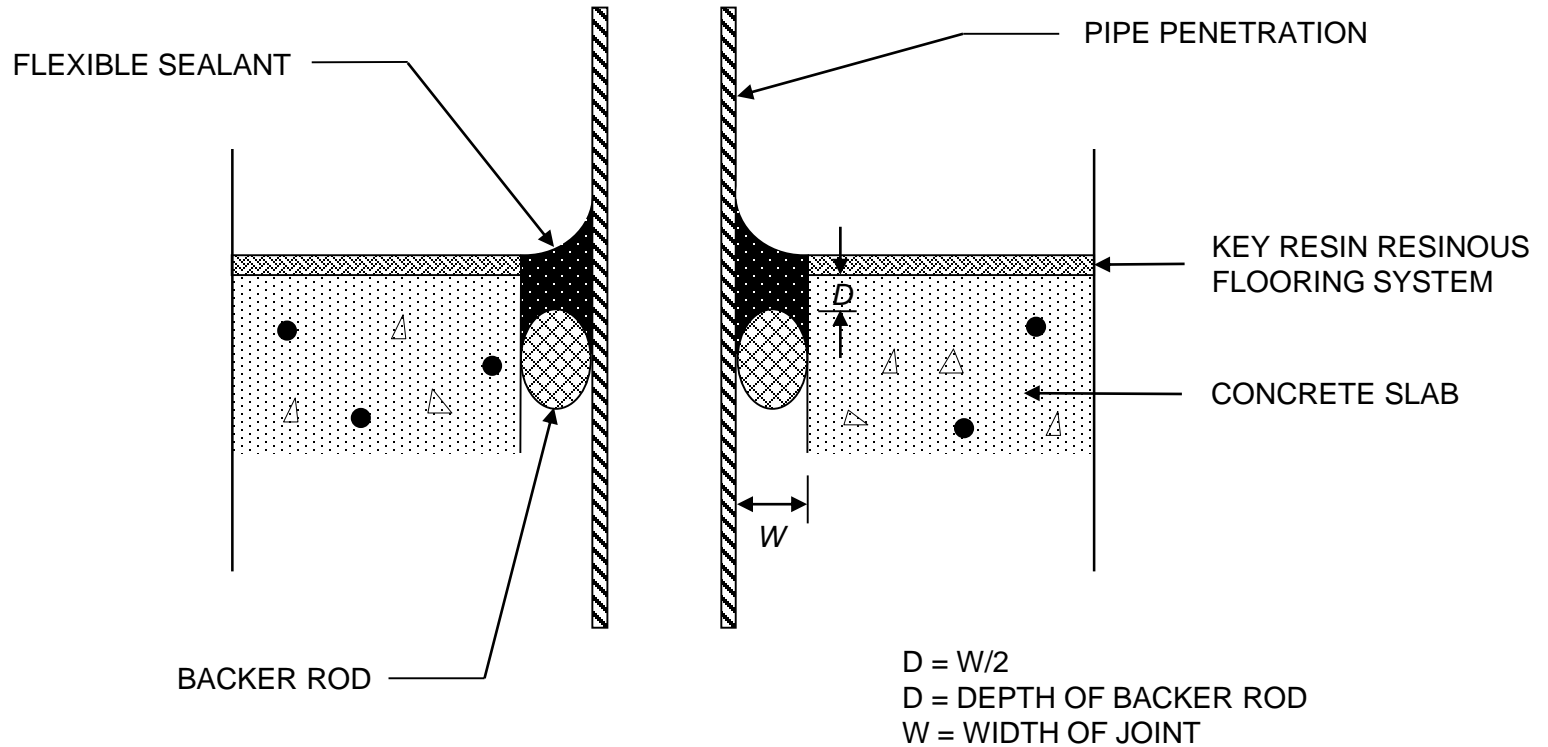

4050 Clough Woods Drive  
Batavia, Ohio 45103  
888-943-4532  
[www.keyresin.com](http://www.keyresin.com)

NOT TO  
SCALE

DATE:  
04/07/16

DETAIL:  
**PIPE PENETRATION DETAIL #2**

FILE #:  
**KEY-DTL-47**

Click For Table of Contents

## STRIPLESS EXPANSION JOINT EPOXY TERRAZZO

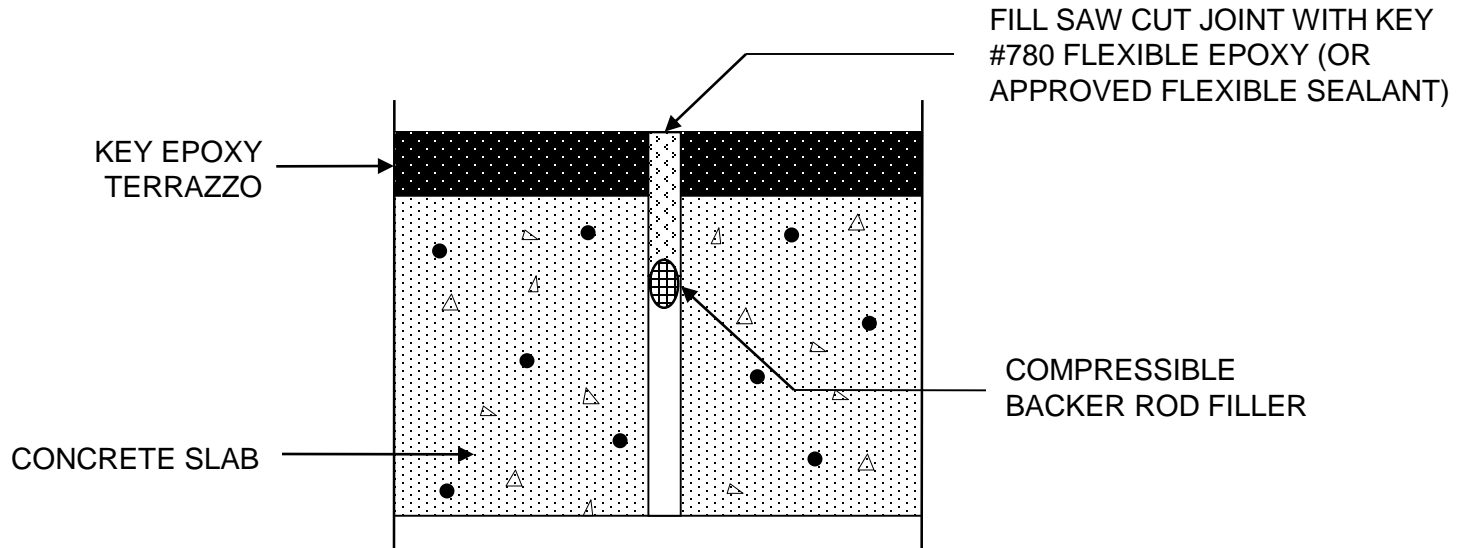

NOTE: FOLLOWING CURE OF INSTALLED EPOXY TERRAZZO FLOOR, SAW CUT ALONG FLOOR EXPANSION JOINT TO RECEIVE FLEXIBLE EPOXY.



4050 Clough Woods Drive  
Batavia, Ohio 45103  
888-943-4532  
[www.keyresin.com](http://www.keyresin.com)

NOT TO  
SCALE

DATE:  
09/24/16

DETAIL:  
**STRIPLESS EXPANSION JOINT DETAIL**

FILE #:  
**KEY-DTL-48**