



STANDARD LITE MOULDINGS

Artistry Collection Only

Non-Rated Doors

VT wood lite mouldings (also known as stops or beads), are shipped loose for field installation. Field fitting of glass, glazing, and stops is the responsibility of the installer. Use of glazing compound or caulking is required. All VT profiles have a tolerance of ± 0.005 . Factory installed glazing is available upon customer request.

Standard wood stop materials are as follows: Doors with laminate faces will use poplar stops. Doors with wood veneer faces will have stops that match the face veneer.

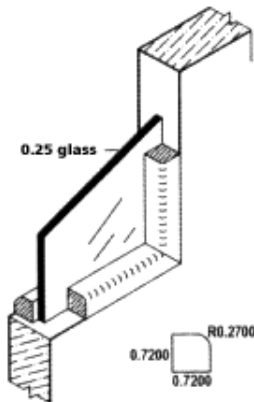

VT1

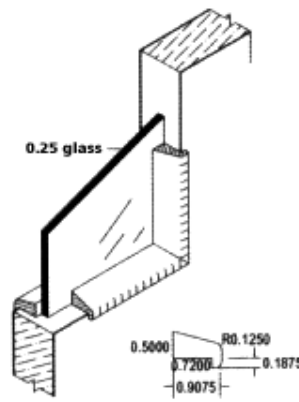

VT3

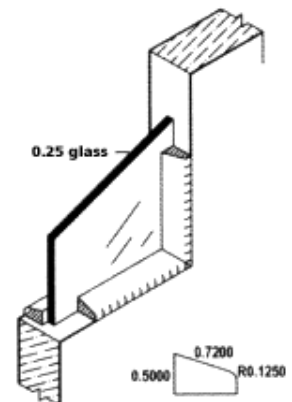

VT7

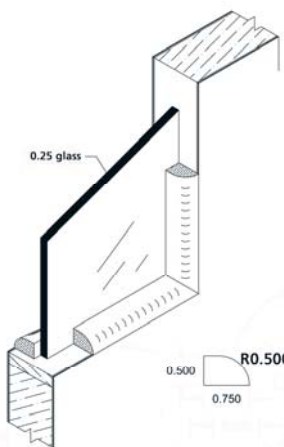

A1

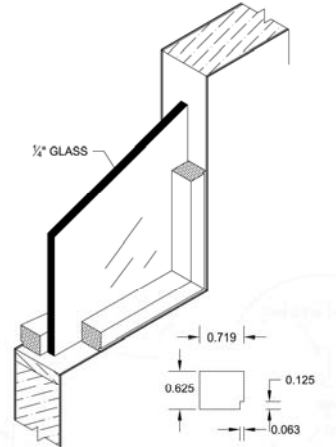

A2

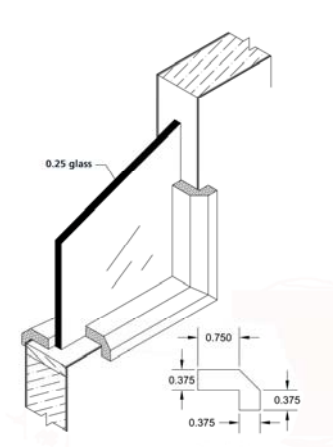

A3

Notes:

- Refer to Product Update #P104F for more details.
- VT wood stops available for glass thicknesses other than noted above, please specify glass thickness on quote request or order. Contact your Customer Service Representative for questions or additional information.

20-Minute Fire Rated Doors

VT wood lite mouldings (also known as stops or beads), are shipped loose for field installations. Fire Clips™ are shipped loose, to be installed with glass and stops. Field fitting of glass, glazing, and stops is the responsibility of the installer. Use of a glazing compound or caulking is required. All VT profiles have a tolerance of ± 0.005 . Factory installed glazing is available upon customer request.

Standard wood stop materials are as follows: Doors with laminate faces will use poplar stops. Doors with wood veneer faces will have stops that match the face veneer.

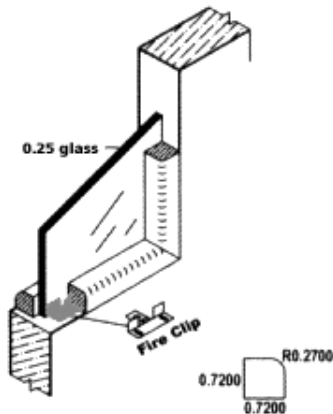

VT1

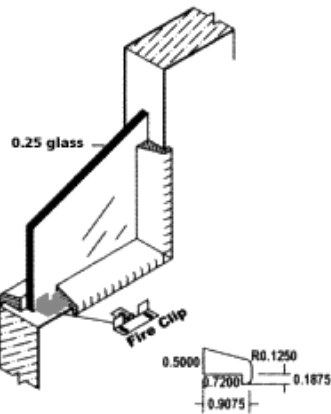

VT3

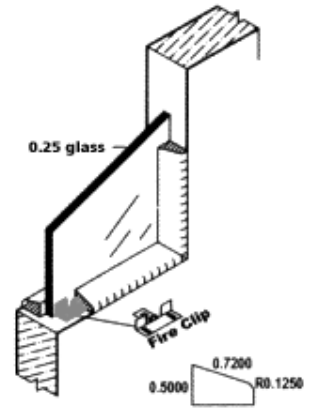

VT7

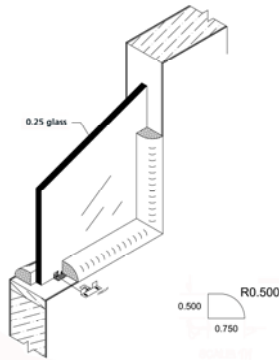

A1

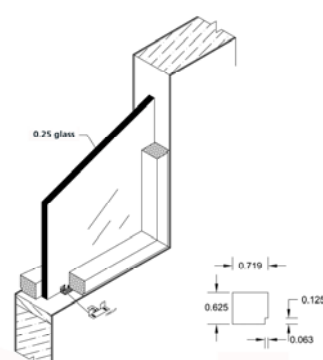

A2

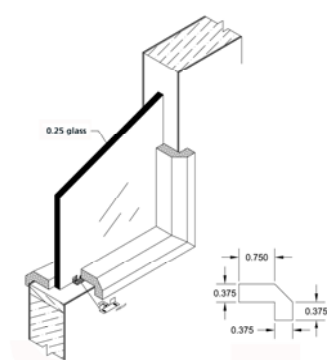

A3

Notes:

- Refer to Product Update #P104F for more details.
- VT wood stops available for glass thicknesses other than noted above, please specify glass thickness on quote request or order. Contact your Customer Service Representative for questions or additional information.
- All 110 Metal Vision Panels are also available. See Heritage Collection.

STANDARD LITE MOULDINGS

Heritage Collection Only

Non-Rated Doors

Flush wood lite mouldings (also known as stops, or beads) have one side fixed into place with brads at the factory. The other side is temporarily tacked into place so glass and glazing can be installed at the jobsite. Field fitting of glass and glazing is the responsibility of the installer. Use of a glazing compound or caulking is recommended to reduce glass rattle. All VT profiles have a tolerance of ± 0.005 . Factory installed glazing is available upon customer request.

Standard wood stop materials are as follows: Doors with laminate faces will use poplar stops. Doors with wood veneer faces will have stops that match the face veneer.

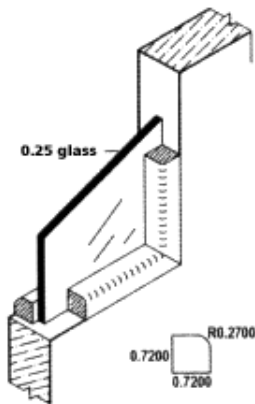

VT1

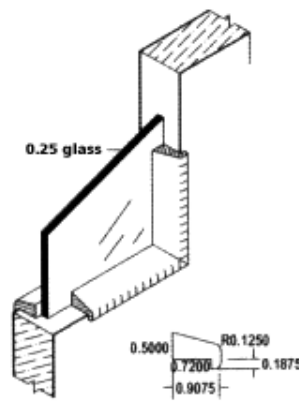

VT3

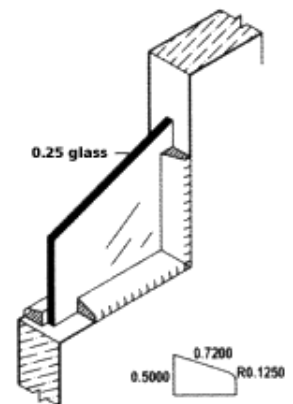

VT7

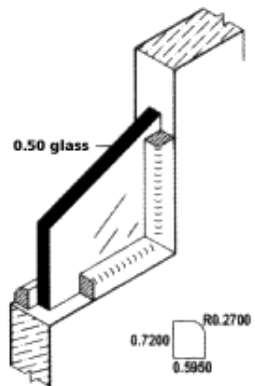

VT9

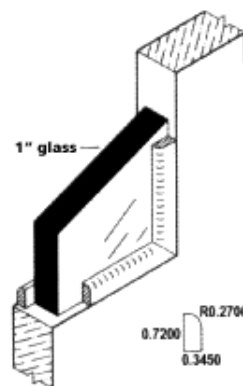

VT15

Notes:

- For acoustical lite kits, refer to Acoustical Doors information in your Order Process Guide.
- Refer to Product Update #P104F for more details.
- VT wood stops available for glass thicknesses other than noted above, please specify glass thickness on quote request or order. Contact your Customer Service Representative for questions or additional information.

20-Minute Fire Rated Doors

VT wood lite mouldings have one side fixed into place with brads at the factory, along with one-half of Fire Clip™. The other side is temporarily tacked into place so glass and glazing can be installed at the jobsite. Remaining halves of Fire Clips™ are shipped loose, to be installed with glass. Field fitting of glass and glazing is the responsibility of the installer. Use of a glazing compound or caulking is required. All VT profiles have a tolerance of ± 0.005 . Factory installed glazing is available upon customer request.

Standard wood stop materials are as follows: Doors with laminate faces will use poplar stops. Doors with wood veneer faces will have stops that match the face veneer.

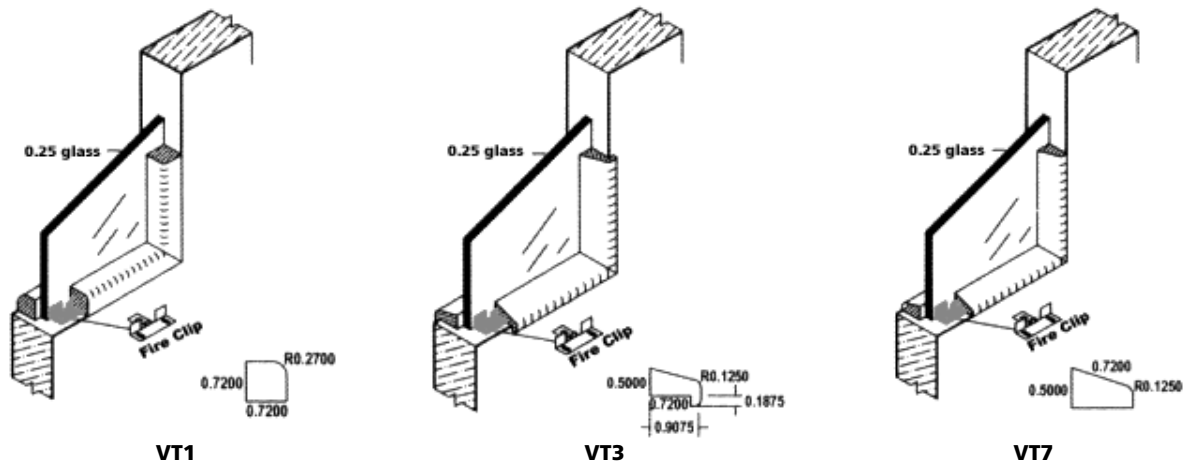

45-, 60- and 90-Minute Fire Rated Doors

Metal vision panels arrive with beige polyester powder coating. Other paint colors are available for additional cost.

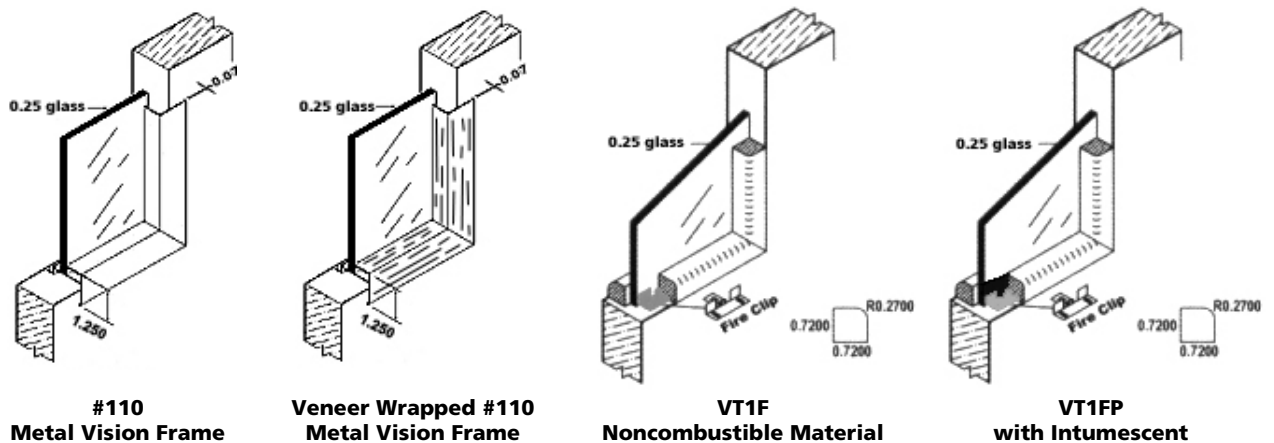

#110 Metal Vision Panels are also available in non rated and 20 minute.

Notes:

- For acoustical lite kits, refer to Acoustical Doors information in your Order Process Guide.
- For lead lined lite kits, see Lead Lined Doors information in your Order Process Guide.
- Refer to Product Update #P104F for more details.
- VT wood stops available for glass thicknesses other than noted above, please specify glass thickness on quote request or order. Contact your Customer Service Representative for questions or additional information.