

# WOODWORKS® Linear Veneered Panels

## Installation Instructions

### 1. GENERAL

#### 1.1 Product Description

WoodWorks Linear veneered panel ceilings consist of unperforated panels that are downward accessible, and are designed to be installed on a conventional Armstrong Prelude® 15/16" wide T-Bar suspension system with T-Bar hooks attached to panels. All panels can be removed and reinstalled for access to the plenum. Panels are supported from the grid system by metal hooks that are screw-attached through predrilled holes. Panels are fitted with safety cables to prevent falling to the floor in the event of loss of grid support.

Available panel size is 2' x 8' and feature nominal 4" wide, nominal 6" wide or tapered planks.

Panels, hooks, screws, and safety cables are sold separately.

For floating or noncontinuous installations, WoodWorks Concealed 6" Trim is available (Item # 6603W1). Options include veneer wrapped aluminum in 6 wood finishes and painted aluminum in black.

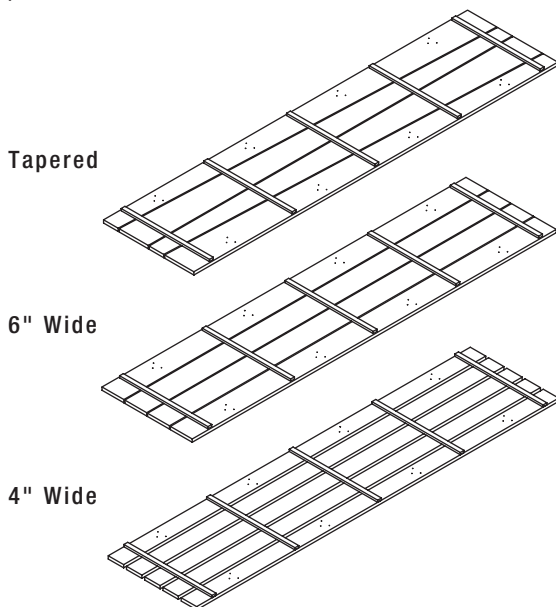

#### 1.2 Material Delivery

Panels are bulk packaged for each job.

- T-Bar Hooks (item 5986) are packaged 50 pieces per carton.
  - 8 hooks are required for each 2' x 8' panel
- Wood Screws (item 91070A244) are packaged 100 pieces per carton. These are serrated thread screws specially designed for use in particle board. Three screws are required for each hook.
- 24" Safety Cables (item 6091) are packaged 50 pieces per carton. Two cables are required for each panel.
- 12' Support Hangers (item SH12) are packaged 12 pieces per carton.
- Nominal 6" x 10' WoodWorks Linear Veneered Panels Trim (item 6603W1) is packaged 6 pieces per carton.
- T-Bar Connector Clips (item FXTBC) are packaged 10 pieces per carton.
- Splice Plates (FX4SPLICE) are packaged 10 pieces per carton.

All materials are ordered through the Armstrong Customer Focus Center 1 877 276 7876.

#### 1.3 Surface Finish

All wood panels are constructed of wood chips factory bonded together between two layers of wood veneer finish. All exposed edges are banded with the same finish as the face.

#### 1.4 Storage and Handling

Ceiling components should be stored in a dry interior location and shall remain in cartons or crates prior to installation to avoid damage. The cartons should be stored in a flat, horizontal position. The protectors between panels should not be removed until installation. Proper care must be taken when handling to avoid damage and soiling. Do not store in unconditioned spaces with humidity greater than 55% or lower than 25% RH and temperatures lower than 50°F or greater than 86°F. Panels must not be exposed to extreme temperatures, for example, close to a heating source or near a window where there is direct sunlight.

## 1.5 Site Conditions

WoodWorks ceiling panels and veneer-wrapped trim should be permitted to reach room temperature and have stabilized moisture content for a minimum of 72 hours before installation. (Remove plastic wrap to allow panels to acclimatize.) They should not, however, be installed in spaces where the temperature or humidity conditions vary greatly from the temperatures and conditions that will be normal in the occupied space.

### 1.5.1 HVAC Design and Operation

Proper design for both supply air and return air, maintenance of the HVAC filters, and building interior space are essential to minimize soiling. Before starting the HVAC system, make sure air supply is properly filtered and the building interior is free of construction dust.

### 1.5.2 Temperature and Humidity During Installation

WoodWorks® ceiling panels are interior finish products that are designed for installation to be carried out in temperature conditions between 50°F (10°C) and 86°F (30°C), in spaces where the building is enclosed and HVAC systems are functioning and will be in continuous operation. Relative humidity shall not fall below 25% or exceed 55%. There shall be proper ventilation of the plenum in high moisture areas.

All plastering, concrete, terrazzo, or any other wet work shall be completely dry. All windows and doors shall be in place. The heating, ventilation, and air-conditioning system should be installed and operable where necessary to maintain proper temperature before, during and after installation of the WoodWorks panels.

### 1.5.3 Color

WoodWorks panels are made with a variety of real wood veneers. Natural variations in color and grain are characteristic of wood products. To maximize visual consistency, panels should be unpacked and examined collectively to determine the most desirable arrangement for installation. Where consistency is critical, Armstrong can offer custom solutions to meet your budget and aesthetic requirements. Consult HPVA for additional information on veneers and veneer grades.

### 1.5.4 Installation Considerations

WoodWorks Linear veneered panels hang below the suspension system to which they are attached. The face of the installed panels will be 2-7/8" below the face of the suspension system from which they are supported. The plenum may be visible through the 1/4" panel reveal.

Use of large wood panels may result in deflection up to 1/8" and alignment inconsistency due to size and ambient conditions.

**Not recommended for sloped ceiling installations.**

## 2. SUSPENSION SYSTEM FOR WALL-TO-WALL INSTALLATION

### 2.1 General

The suspension system shall be Heavy Duty 15/16" exposed tee grid. The installation shall, in all cases, conform to the requirements of the International Building Code and its referenced standards. Because these panels weigh in excess of 2.5 lb/sf, the ceilings shall be installed per IBC Seismic Design Categories D, E, and F. Included in these requirements is the use of stabilizer bars or some other means to positively prevent the grid from separating at the walls. Additionally, walls or soffits that serve to support a panel edge must be braced to structure so as not to allow movement greater than 1/8" when subjected to design lateral force loads. When such bracing is not practical or is not effective additional mechanically connected grid components shall be provided to capture all edges of every panel. Axiom trim connected to the grid with AXTBC clips will also meet this requirement.

The requirements listed here represent the manufacturer's minimum acceptable installation recommendations, and may be subject to additional requirements established by the local authority having jurisdiction.

### 2.2 Load Capacity

WoodWorks panels weigh 2.75 lb/sf. Therefore, heavy duty main beams are required by building code. Main beams must be capable of carrying the weight of the panels plus any additional ceiling components that are not independently supported from the building structure.

### 2.2.3 Grid Installation

The suspension system for this system does not line up with the panel edges. Main beams are located one foot in from the short sides of the panels and then at 2' centers. Cross tees are placed directly over the edges of the long sides of the panels. Follow these instructions carefully to complete the installation of the suspension system.

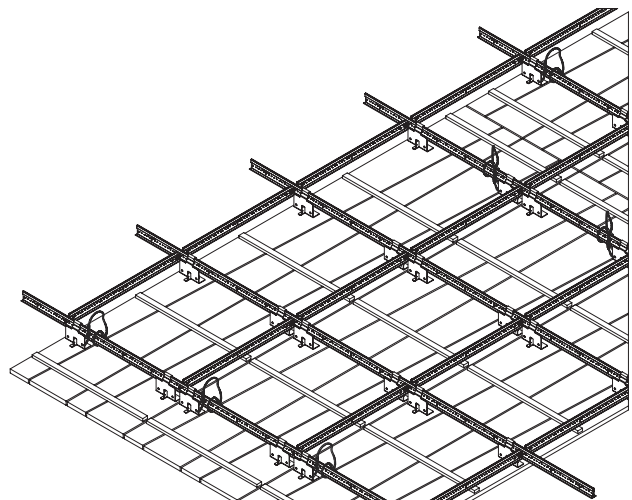

### 2.2.4 Wall Molding

The International Building Code requires a molding with a minimum 2" horizontal leg. However, where our ESR1308 report is accepted, a 7/8" leg may be substituted when used along with our BERC2 clip.

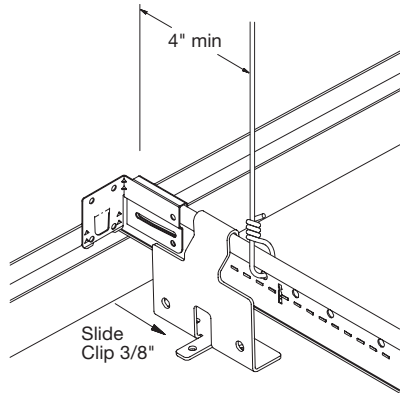

**NOTE:** When BERC2 is used, the clips adjacent to the molding must be relocated 3/8" toward the center of the panel. Draw lines through the factory drilled pilot holes across the back of the panel. Shift the outer clips 3/8" toward the center of the panel and secure each with three screws.

**NOTE:** Perimeter wires must be attached to the terminal ends each piece of grid at least 4" but not greater than 8" from the wall. These wires must be plumb within 1 in 6 (10° angle).

The 2" leg molding will provide a reveal of 1-5/8" between panel edge and wall. The reveal with a 7/8" molding will be 1/2".

Attach the desired molding to the walls 2-7/8" above the finish ceiling height.

### 2.2.5 Support Hanger

SH12 support hanger can be used to reduce the number of hanger wire attachments to main beams. If the support hanger is not used, hanger wires will be required on main beams every 4 feet along the main. Where sections of support hanger must be joined together, overlap one notch and secure with framing screws inserted through the holes provided.

### 2.2.6 Main Beams

Typical placement of the main beams is one foot in from the factory end of the panels and then at 2' centers. Up to 10" may be cut from the end of a panel before the grid location at the cut end must be altered. When more than 10" must be removed, install a main beam one foot closer to the center of the panel. Open the mouth of the support hanger notches where mains must be installed by bending with a pair of pliers. Cut the first main beam in each row to provide a cross tee rout hole at the long edge of the first row of panels. Insert the main beams into the support hanger notches and close the mouth by bending the tab back under the bulb of the main. Work carefully to ensure that each tab is properly seated under the bulb of the main.

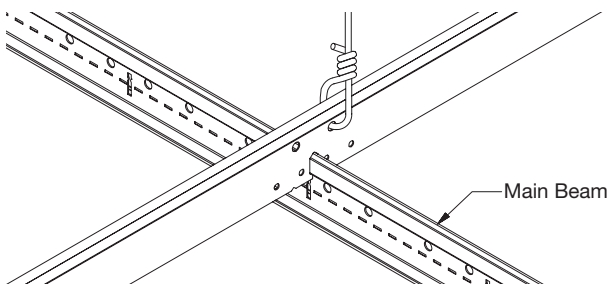

### 2.2.7 Cross Tees

Install 2' cross tees above the long edges of the panels to complete the grid installation. Swing the support hanger out of the way to provide clearance for the end details on the tees. Install all of the cross tees in a row and then secure the support hanger by inserting a framing screw through the hole provided and into the bulb near each end of each tee.

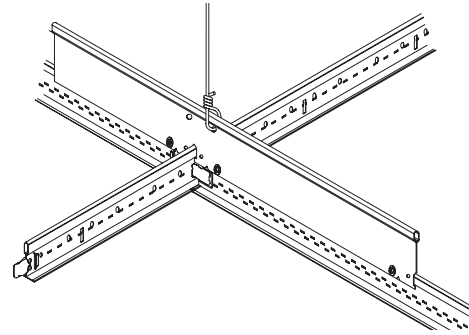

### 2.2.8 Perimeter Attachment

Secure the ends of the grid at two adjacent walls by attaching to the wall molding flange. Screws or pop-rivets may be used for this connection. Use stabilizer bars or BERC2 clips to prevent the grid from spreading at the opposite ends.

### 2.2.9 Complete Seismic Installation Requirements

Install perimeter wires and lateral force bracing. Check to ensure that all code based installation requirements have been met.

## 3.0 PANEL INSTALLATION

### 3.1. Cutting the Panel

Cut the panel using standard wood working tools and, where possible, a straight edge. A table saw is recommended for straight cuts and a band saw for curved cuts. In general, these practices will be typical of those employed in finish carpentry.

**▲CAUTION! WOOD DUST.** Sawing, sanding and machining wood products can produce dust. Airborne wood dust can cause respiratory, eye and skin irritation. The International Agency for Research on Cancer (IARC) has classified wood dust as a nasal carcinogen in humans.

**Precautionary measures:** Avoid inhalation of dust. If power tools are used, they should be equipped with a dust collector. If high dust levels are encountered, use an appropriate NIOSH-designed dust mask. Avoid dust contact with eyes and skin.

### First Aid Measure in case of irritation:

Flush eyes or skin with water for at least 15 minutes.

### 3.1.2 Starting Row

Check the orientation of the hooks when attached to the predrilled holes on the back of the panel. The starting row must be installed such that the open side of the hooks will be facing the wall. Cut the panel as required considering the reveal dimensions listed in section 2.2.4.

### 3.1.3 Relocating Hooks

If cutting the panel will remove any of the hook attachment holes these should be relocated prior to cutting.

### 3.1.4 Cutting the Long Edge

When the long edge of the panel is to be cut, first use a straight edge to draw lines across the back of the panel through the factory holes. Cut the panel to size. Attach a T-Bar Hooks (item 5986) to each set of factory drilled holes; three screws are required in each clip. Measure the grid opening and place clips on the reference lines so that the dimension from the outer edge of the factory located clip to the outer edge of the relocated clip matches the grid opening dimension. Drill pilot holes at the new screw locations. Use a stop on the drill to prevent penetrating through the panel. Attach the relocated clips with three screws in each.

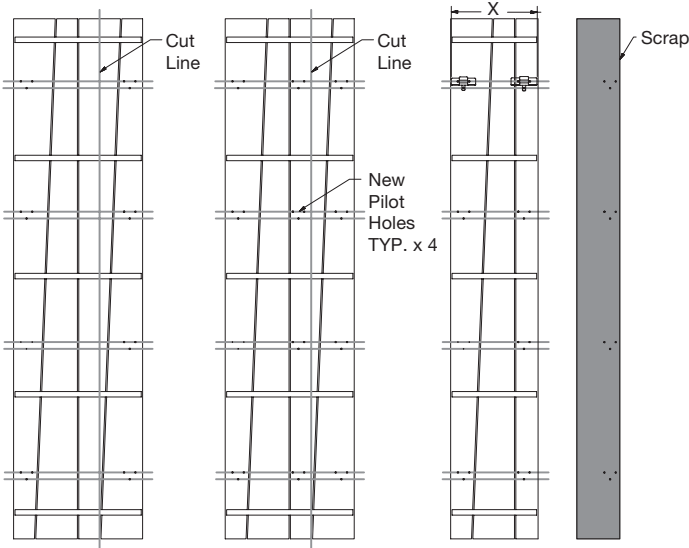

### 3.1.5 Cutting the Short Edge

Up to 10" may be cut from the narrow end of a panel without moving clip locations. When more than 10" must be removed begin by carefully measuring back 12" from the factory holes toward the center of the panel and draw lines across the back of the panel. Cut the panel and attach the hooks to the factory holes and on the lines. Be careful to maintain the correct position along the lines. Measure the factory holes for uncut edges and follow the procedure in section 3.2.2 where the long edge has also been cut. Each clip must have three screws installed. NOTE: Pre-drill holes prior to installation.

In the event that a backer is going to interfere with the new location of the clips, the backer must be repositioned and reattached so there is a minimum of 3" clearance between the backer and the clips (drawing C).

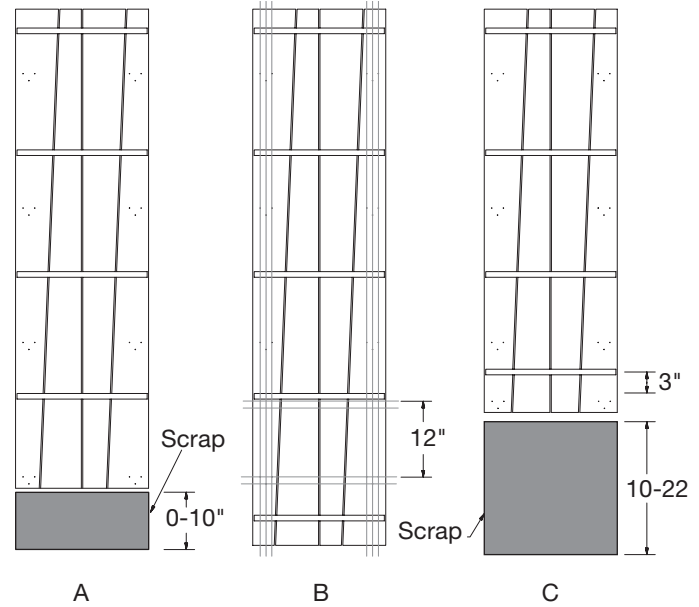

### 3.1.6 Attach Clips

Attach a T-Bar Hook (item 5986) at each set of factory drilled pilot holes on each panel. Three screws (item 91070A244) are required in each clip.

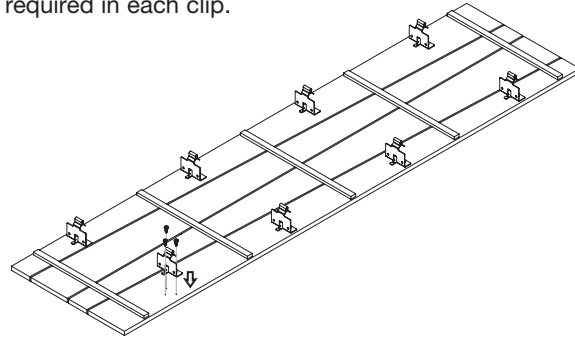

### 3.1.7 Treating Exposed Edges

Cut panel edges that are exposed to view will have to be treated to look like factory edges. Pre-finished peel and stick edge banding is available for this purpose. Cut edge must be clean and smooth before applying edge banding. Peel off the release paper and apply the edge banding using finger pressure or a small trim roller. Trim excess material with a sharp knife blade or with the edge trimmer available for order through Armstrong. For finishing edges on floating or noncontinuous installations, see section 5 in these instructions.

### 3.1.8 Ordering Edge Banding Material

Pre-finished pressure sensitive adhesive banding is available 15/16" wide and in 25' lengths. Edge banding and trimming tools are ordered directly from Armstrong through the Customer Focus Center.

### 3.2 Install the Panels

#### 3.2.1 First Row

First row panels are installed with the open side of the clips facing the wall. Raise the hooks above the level of the grid and move the panel toward the wall. Lower the clips onto the bulbs of the main beams. The clips will fit between the cross tees and center the panels under the grid opening. Attach two safety cables at diagonal corners of the panel. Cinch the loop end of the cable around the main beam and connect the clip at the other end to one of the holes on the hook.

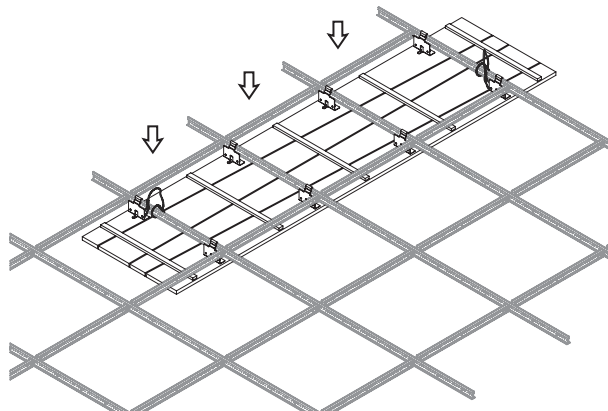
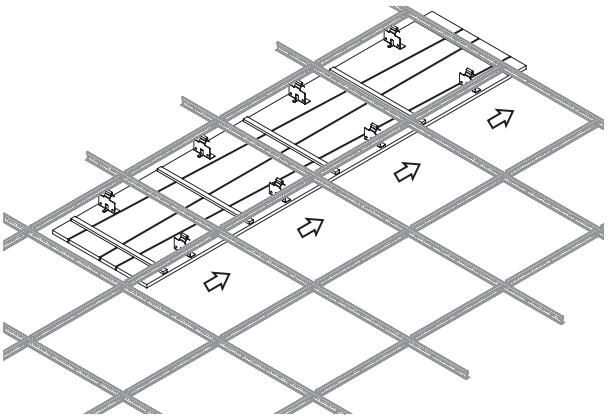
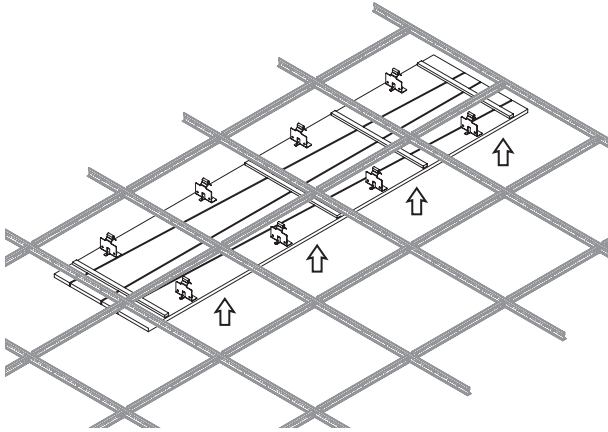

#### 3.2.3 Middle Rows

Apply hooks to the remaining full size panels and install in the same direction as the first row. Attach two safety cables to each panel as they are installed.

#### 3.2.4 Last Row

Panels in the last row are reversed so that they install with the open side of the hooks facing the ending wall. Prepare the panels as detailed in section 3.0. Raise the factory end of the panel up and over the end of the one in the next to last row to allow the hooks to clear the grid. Shift the panel up and toward the wall to engage the hooks onto the main beams. Install safety cables as the installation progresses. Cables on the last panel must be attached before the panel is positioned in the ceiling.

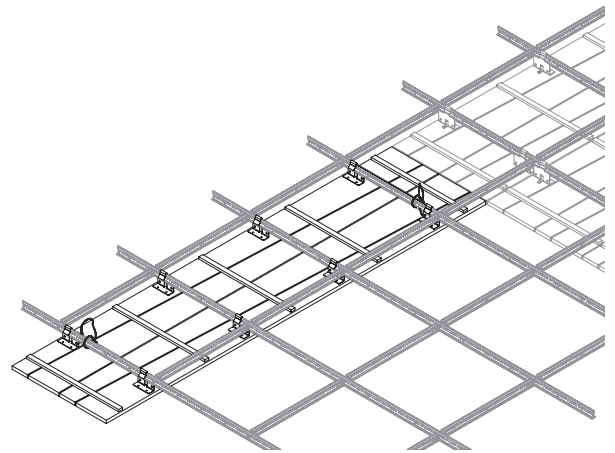
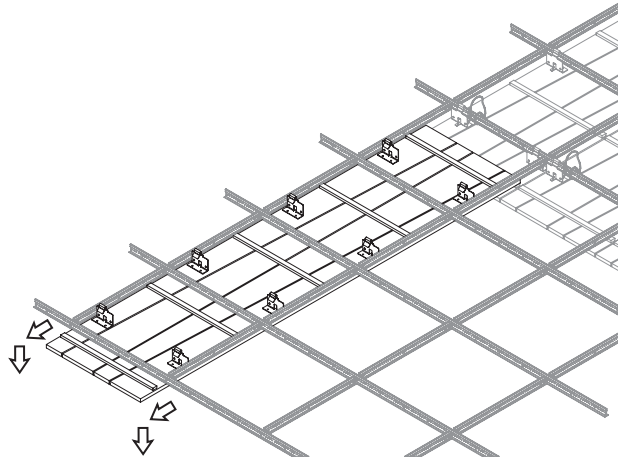
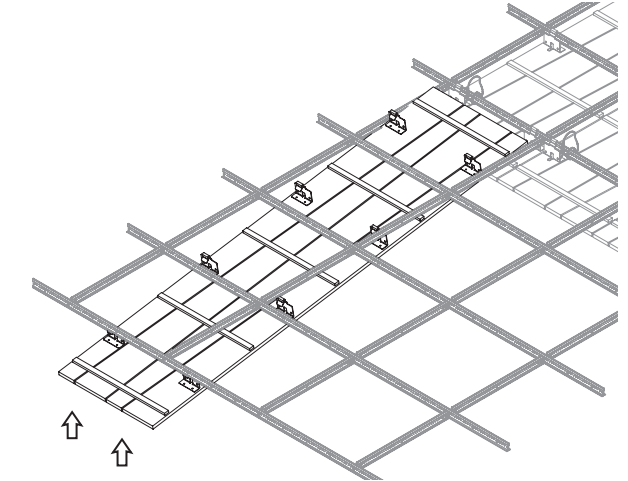



#### 4. PANEL REMOVAL

Panels are easily removed by lifting to disengage the hooks from the main beams. Lift and shift in the long direction of the panel. Border panels will always move away from the wall. Panels in the center of the installation will only move in one direction. Once the hooks have cleared the grid lower the free end of the panel until the hooks near the upper end can clear the grid. Remove the safety cables from the clips and lower the panel to the floor.

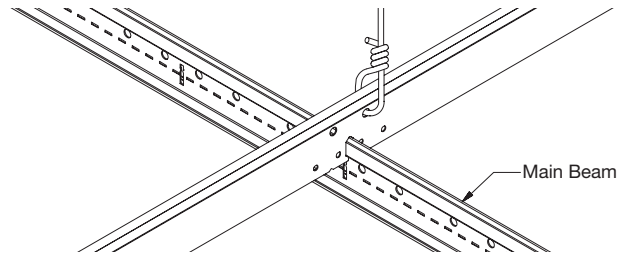

#### 5. FLOATING INSTALLATION USING WOODWORKS® CONCEALED TRIM

A minimum 2-panel long installation is recommended for floating installations with WoodWorks® Concealed Trim (item 6603W1). For installations with cut panels, please follow tips in sections 3.1.4 and 3.1.5.

##### 5.1 Pre-Assembly

Review the location of the SH12 carrying channels. They will be located 2' from the longest side of the cloud and then 4' on center (note that in some instances this pattern will result in two SH12 carrying channels being positioned 2' from one another at the center of the cloud). Cut and splice SH12 together (if needed) to match the length of the cloud.

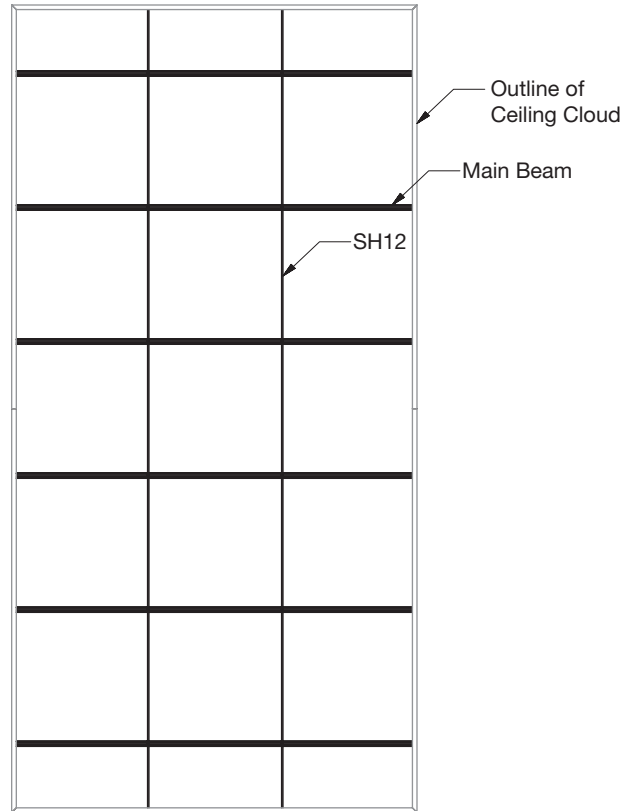
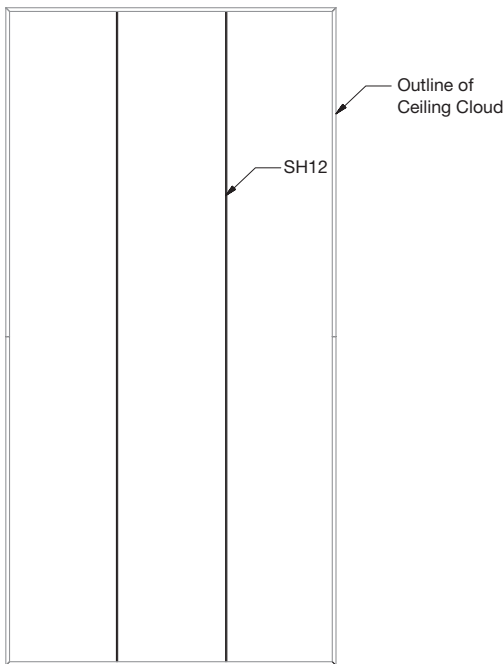

##### 5.2 Install Mains

The main beams for a WoodWorks Linear Veneered Panels floating installation should be cut to the nominal width of the cloud. For example, for a nominal 8' wide cloud, cut the main beams to 8' or 96". These cuts should be made through a rout at both ends of the main beam. This will help to keep the right spacing for the cross tees in the system.

Install mains into the appropriate notches on the SH12 Hanging Channels. The first main will be 1' from the end of the channel and the remainder will be placed at 2' centers. Slide the main through the notches or bend the tab on one side of the notch out of the way so that the main can be installed from below. Bend the tab back into position under the bulb of the main.

##### 5.3 Install Cross Tees

Install 2' cross tees between mains. After all tees have been installed, slide the SH12 Hanging Channel along the mains so that it rests against the cross tees. Screw the support channel to the tees by inserting a #8 x 9/16" sharp point sheet metal screw into the holes on each side of the main as shown in the drawing below. Bend the tabs at the ends of the SH12 support channel as shown so that they will fit under the bottom of the bulb of the tees and secure with a #8 x 9/16" screw. Cut 1' cross tees and insert into outside mains to match 2' cross tees. Secure with screws.

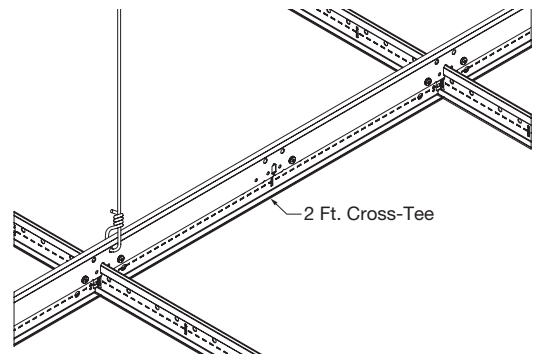

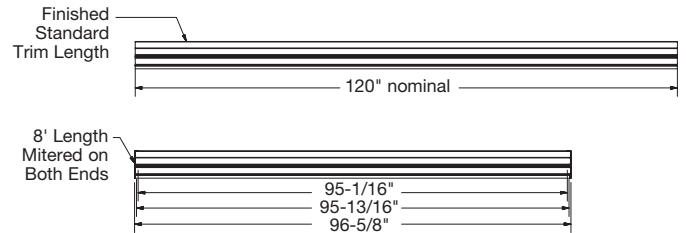
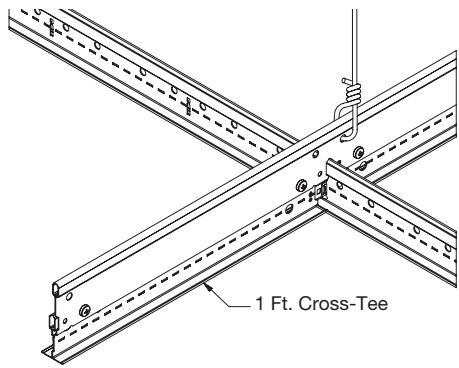

Test one piece of trim running the length of install to make sure the FXTBC clips are positioned correctly (measurement from T-Bar hook flange to cross tee should be 23-1/16" – standard 2' x 2' grid opening).

#### 5.4 Attach Trim Clips to Mains and Cross Tees

Attach trim clips (item FXTBC) to end of each main runner and cross tee by positioning as shown in the drawing. The top of the clip should touch the bottom of the bulb of the grid and the end of the main should align with bend in clip. Secure each clip with two pop-rivets or #8 sheet metal screws (screws are used so clips can be adjusted).

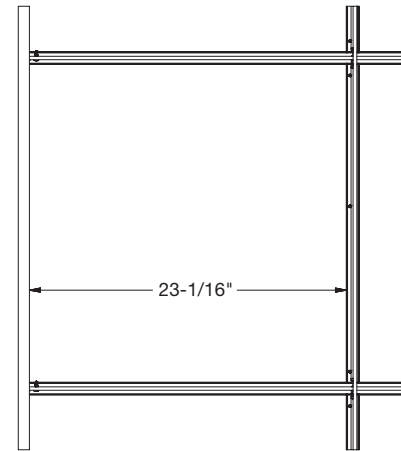
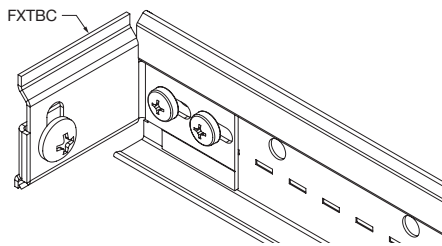

#### 5.5 Cut and Miter Trim

WoodWorks® Concealed Trim (item 6603W1) is available in 10' lengths with 6 pieces per carton. Cut trim sections and miter ends accordingly. Trim can be field-mitered using a power miter saw equipped with a blade designed to cut aluminum.

#### 5.5.1 Attach Splice Plates to Trim

Steel splice plates (item FX4SPLICE) are used to align and secure all joints between sections of trim. Two splice plates are required at each joint. Bend the splice plate at the center notches to form the desired corner angle. Splice plates are secured to the trim sections using factory-installed set screws. Where desired, it may be beneficial to caulk or tape the backside of the joints to prevent light transmission. To install splice plates, position the splice plate in the bosses on the inside of the trim.

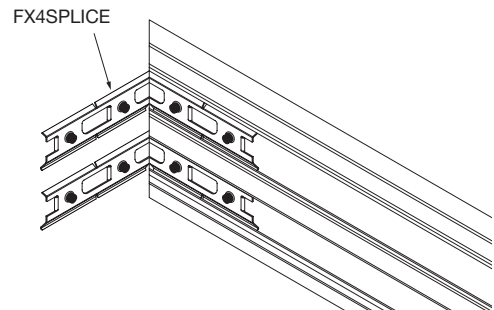
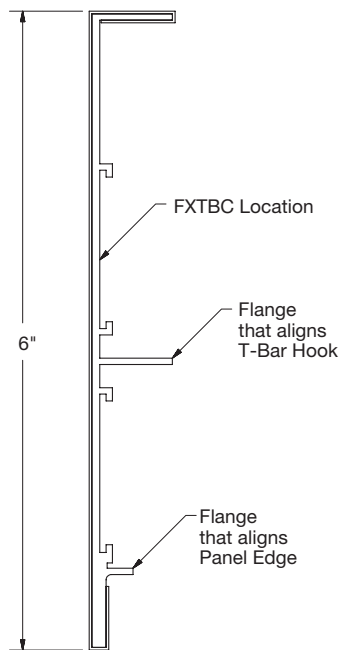

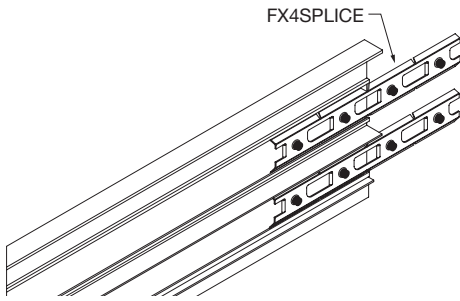

### 5.5.2 Install Trim

Install trim sections to main runners and cross tees by fastening FXTBC clip to trim. Make sure all main runners and cross tees stay straight and square while the trim is installed (main runner and cross tee position is critical for panel installation).

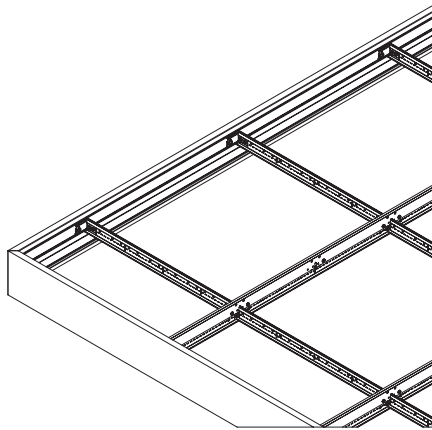
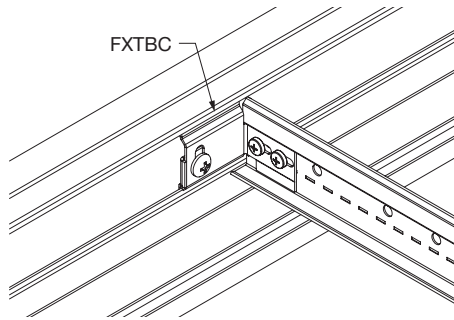

### 5.5.3 Corner and Straight Joint Assembly with Splice Plates

To secure each corner, position the mitered corner for correct alignment and tighten the two set screws on the splice plate (item FX4SPLICE). Fasten the corner splice plates by starting at one corner and working around to the other three corners. Then, fasten the splice plate at the flat joints.

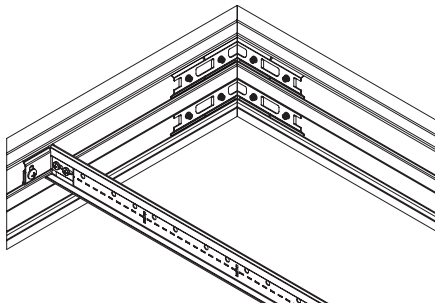

To secure splice plates for straight trim joints, pull the trim tightly together for the best fit. Use a 1/8" hex key wrench to tighten the set screws that secure splice to trim. **CAUTION:** Do not over-tighten these screws to the point where they distort the face of the trim.

When splicing straight sections of trim together, the trim joint should fall between the grid connections, as detailed below, so it will not interfere with the FXTBC and grid connection. Trim for clouds wider than 8' should be cut so the joint is located between cross tee connections.

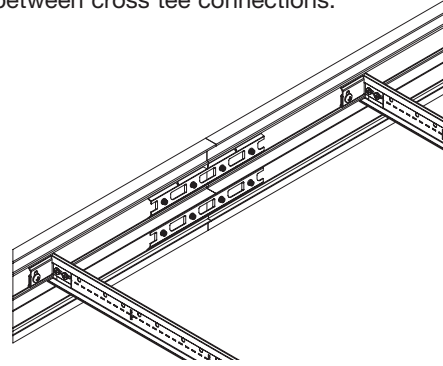

## 5.6 Install the Panels

### 5.6.1 First Row

First row panels are installed with the open side of the clips facing the trim. Raise the hooks above the level of the grid and move the panel toward the wall. Lower the clips onto the bulbs of the main beams. The clips will fit between the cross tees and center the panels under the grid opening. Attach two safety cables at diagonal corners of the panel. Cinch the loop end of the cable around the main beam and connect the clip at the other end to one of the holes on the hook.

### 5.6.2 Middle Rows

Apply hooks to the remaining full size panels and install in the same direction as the first row. Attach two safety cables to each panel as they are installed.

### 5.6.3 Last Row

Panels in the last row are reversed so that they install with the open side of the hooks facing the trim. Prepare the panels as detailed in section 3.0. Raise the factory end of the panel up and over the end of the one in the next to last row to allow the hooks to clear the grid. Shift the panel up and toward the wall to engage the hooks onto the main beams. Install safety cables as the installation progresses. Cables on the last panel must be attached before the panel is positioned in the ceiling.

## 6. SEISMIC RESTRAINT

WoodWorks® Linear Veneered Panels have been engineered for application in seismic areas. This system has been successfully tested in applications simulating seismic design categories D, E, and F. For applications in seismic zones, review the following guidelines.

Check local code for the need for lateral bracing and/or compression posts/splay wires, perimeter wires and for additional installation requirements.

## 7. CLEANING RECOMMENDATIONS

WoodWorks Linear Veneered Panels can be cleaned with a soft, dry cloth.



## **MORE INFORMATION**

For more information, or for an Armstrong representative, call 1 877 ARMSTRONG.

For complete technical information, detail drawings, CAD design assistance, installation information and many other technical services, call TechLine™ services at 1 877 ARMSTRONG or FAX 1 800 572 TECH.

For the latest product selection and specification data, visit [armstrong.com/woodworks](http://armstrong.com/woodworks).

U.S. Patents Pending, including US Publication No. 2004/0182022.

All trademarks used herein are the property of AWI Licensing Company and/or its affiliates  
© 2012 AWI Licensing Company • Printed in the United States of America

BPLA-297857-1012

