

Load Master™ II

Nylon Cantilever Roller

As a leading supplier of fence solutions, Master Halco is dedicated to providing a broad range of products that support your business and help drive success.

Our Load Master™ II cantilever rollers are constructed to the highest quality standards.

Contact your local Master Halco branch representative for more information on how to put the Load Master™ II to work for you.



Load Master™ II
roller cover

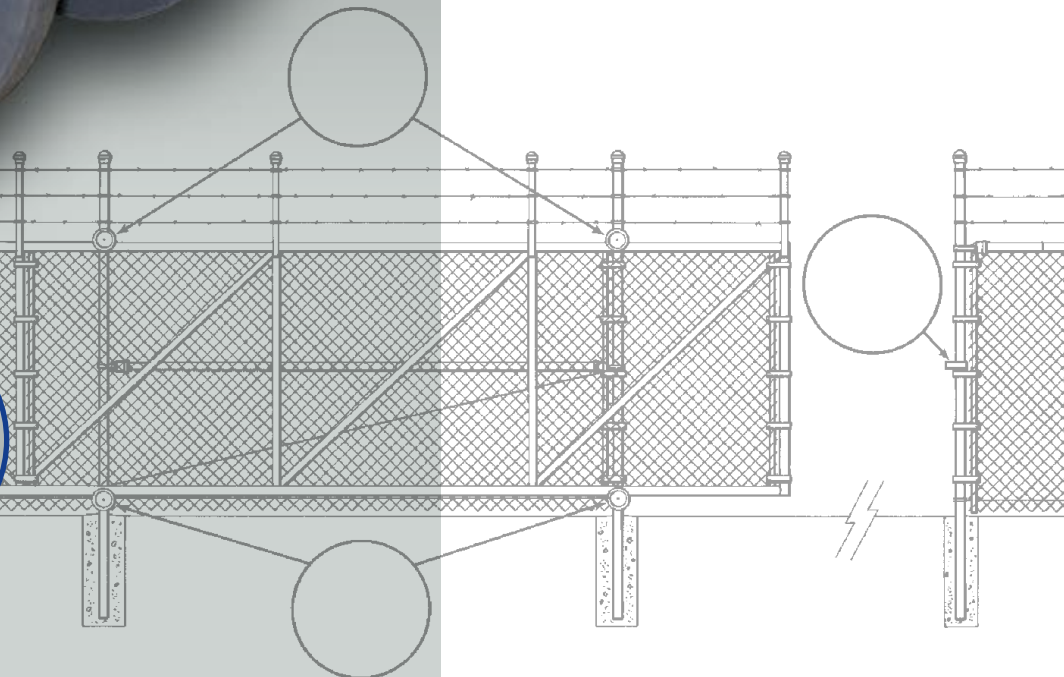

Load Master™ II Nylon Cantilever Roller

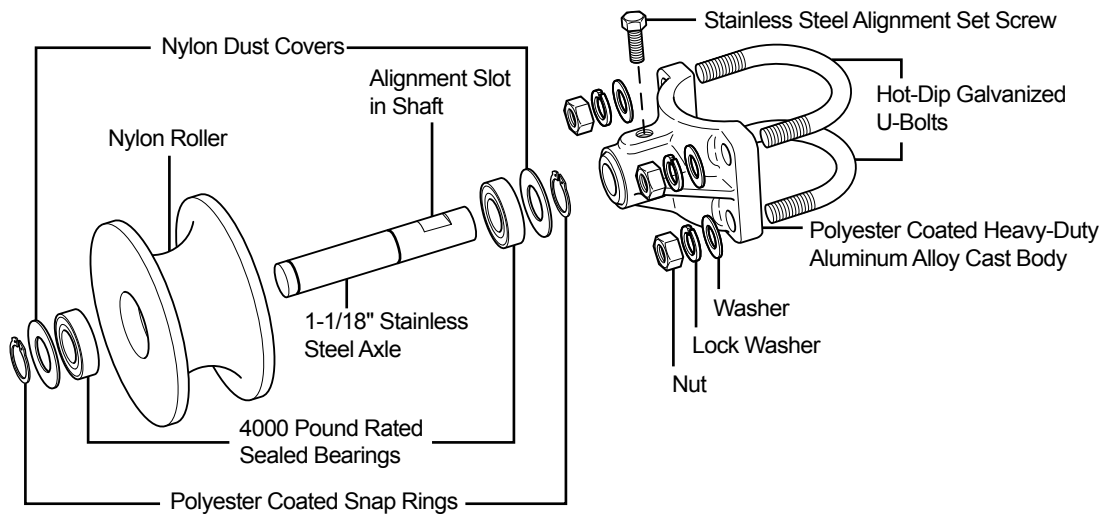

- 4000 Pound rating operates the heaviest of gates
- Strong aluminum alloy cast body for durability
- Easy rolling for manual and electrically operated gates
- UV impregnated nylon/fiberglass wheel for discoloration protection
- 1-1/8" Stainless steel shaft for added strength and corrosion protection
- Sealed bearings provide maintenance-free operation
- Slot in axle and set screw allows wheel to move in and out of body for perfect alignment
- Nylon dust covers to prevent damage to the bearing on each end of the shaft
- Polyester coated body to eliminate oxidation
- Polyester coated snap rings to prevent rust

5-Year Limited Warranty

LOAD MASTER II NYLON CANTILEVER GATE ROLLER

Heavy Industrial – Aluminum Alloy Cast Body

NOTE: Bolts included.

DESCRIPTION	PART NO.	PER BOX	WEIGHT EA.
4" Post x 2-3/8" Roller with Cover	018349	2	11.29 lb.
4" Post x 2-3/8" Roller	018369	4	10.10 lb.
6-5/8" Post x 2-3/8" Roller	018350	4	13.20 lb.
Covers (fits all sizes)	018348	4	1.19 lb.

SAFETY NOTE:
ALL CANTILEVER ROLLERS
REQUIRE ROLLER COVERS
OR GUARDS.



A Tradition of Fencing Solutions

MasterHalco.com | 888-MH-Fence

Branch service centers are located
throughout North America.

MH 046255 © 05/10

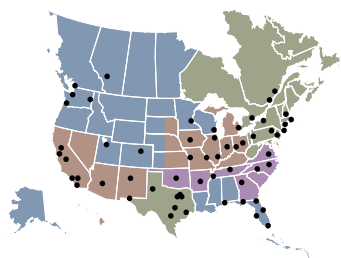

Available from:

