

Insulation Hanger System **Thermafiber® Impasse® Hangers**

- + Provides up to 3 hour fire protection in curtain wall systems
- + Patented design provides enhanced insulation support and security
- + Saves time and money over traditional insulation pins
- + Easy to install
- + UL approved and listed

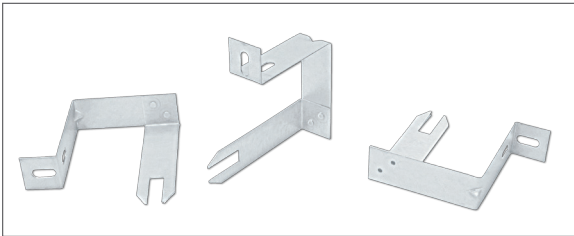

Insulation
Minimum
70%
Recycled
Content



Impasse hangers were used to secure the Firespan™ curtain wall insulation for the perimeter fire containment system in the 555 Mission building in San Francisco, CA. Thermafiber insulation also contributed to the LEED® silver rating for this building.



Impasse® hangers and locking washers are installed into Firespan® curtain wall insulation before inserting the insulation into the spandrel area.

Thermafiber® Impasse® Hangers

Description:

THERMAFIBER® Impasse® insulation hangers and locking washers are designed to provide superior insulation security and support where mechanical attachment is a requirement. Impasse saves time over traditional insulation pins by reversing the order of installation. The patented design also requires less hangers than traditional pins. The reversed installation order allows users to insert the Impasse hangers directly into the insulation and then install the insulation panel directly into the opening. Traditional insulation pins require users to install the pins in the opening first and then force the insulation onto the pins.

Product Options:

- Vertical Hangers sizes are available 2" – 5" sizes in half inch increments.
- Horizontal Hangers sizes are available in 2"-5" in half inch increments.
- Custom sizes are available upon request.

Installation:



The Impasse hanger is impaled into the insulation. The forked leg provides quick, easy installation.



The forked leg of the hanger provides a shelf-like ledge to support the insulation.





A locking washer is slid over the hanger to fit tightly against the insulation panel.

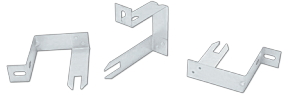

The forks are bent in opposite directions.

Standard Sizes:

Product		Sizes*
Impasse Vertical Hanger		2" - 5" in ½" increments
Impasse Horizontal Hanger		2" - 5" in ½" increments
Impasse Locking Washers		1 size
*Hanger Size = insulation thickness, Custom sizes and designs are available upon request		

Fire Containments Systems:

UL® Approved Designs Under ASTM E2307		
CW-D-1012	CW-D-2038	CW-D-2047
CW-D-1013	CW-D-2039	CW-D-2048
CW-D-1014	CW-D-2040	CW-D-2049
CW-D-1015	CW-D-2041	CW-D-2050
CW-D-1016	CW-D-2043	CW-D-2051
CW-D-1017	CW-D-2044	CW-D-2052
CW-D-2036	CW-D-2045	CW-D-2055
CW-D-2037	CW-D-2046	

Thermafiber® Insolutions®:

Thermafiber offers industry leading technical and engineering assistance to architects, specifiers, and contractors. These services include CAD drawings, engineering judgments, LEED® Credit Information, product recommendations, and customized products. Contact our technical services department at 1-888-834-2371, or email technicalservice@owenscorning.com.

For Further Information:

For additional information about these or other Thermafiber products contact us at 1-888-834-2371 or visit our website www.thermafiber.com.

Notice:

THERMAFIBER, Inc. shall not be liable for incidental and consequential damages, directly or indirectly sustained, nor for any loss caused by application of these goods not in accordance with current printed instructions or for other than the intended use. THERMAFIBER liability is expressly limited to replacement of defective goods. Any claim shall be deemed waived unless made in writing within thirty (30) days from date it was or reasonably should have been discovered.

Submittal Approvals:

Job Name	
Contractor	Date

