

JOS-Crnr090

Facility Protection

High Impact Corner Guard



Product Guide



Exterior



Interior



Weather Resistant



Heavy Impact

- ▶ The Gold standard for corner protections.
- ▶ Heavy duty EPDM corner guard snaps onto a galvanized steel retainer clip.
- ▶ Large collision chambers cushion door impacts better than any other corner guard. Also the corner guard is more forgiving on side panels and plastic bumpers
- ▶ Easy to Install, and easy to replace if damaged or ripped off its retainer
- ▶ Galvanized steel retainer clip protects the facility's structural integrity.
- ▶ Corner guard height: 39" [1m]

JOS-Crnr090 system shown

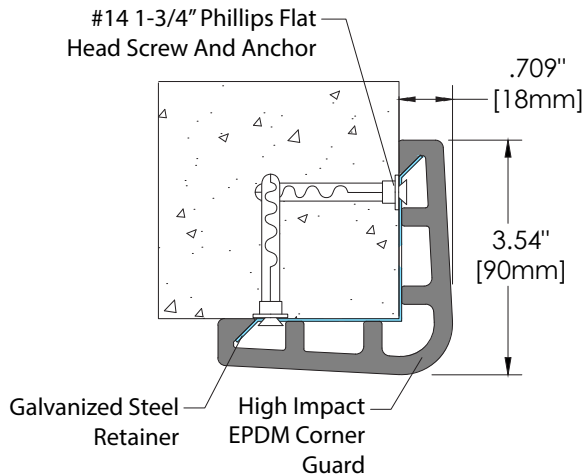

IPC.1602/REV.4

Inprocorp.com • 800.222.5556 • 262.679.9010
World Headquarters S80 W18766 Apollo Drive, Muskego, WI 53150 USA

JOINTMASTER™
EXPANSION JOINT SYSTEMS
A DIVISION OF INPRO®

JOS-Series

Suggested Specification

Part 1 - GENERAL

1.01 SUMMARY

- A. Rubber wall guards for wall and corner protection
- B. Recycled rubber traffic calming and parking assist products

1.02 SECTION INCLUDES

- A. Heavy Duty Rubber Wall Guards
- B. Heavy Duty Rubber Corner Guards
- C. Recycled Rubber Traffic Calming Products
- D. Recycled Rubber Parking Assist Products

1.03 REFERENCES

- A. British Standard (BS)
- B. International Rubber Hardness Degree (IRHD)
- C. American Standard for Testing and Materials (ASTM)

1.04 SYSTEM DESCRIPTION

- A. Performance Requirements Wall and Corner Guards: Provide heavy duty rubber wall/ corner guards that conform to the following requirements of regulatory agencies and the quality control of Joint Master, InPro Corporation.
 - 1. Tensile: Provide heavy duty rubber wall and corner guards with a maximum tensile of 14 mn/m², when tested in accordance with BS 903 A2.
 - 2. Elongation: Provide heavy duty rubber wall and corner guards with a 300% minimum elongation when tested in accordance with BS 903 A2.
 - 3. Hardness: Provide heavy duty rubber wall and corner guards with a hardness of 65-75 IRHD when tested in accordance with BS 903 A26.
 - 4. Compression Set: Provide heavy duty rubber wall and corner guards with a maximum compression set of 30% when tested in accordance with BS 903 A6A for 22 hours at 70°C.
 - 5. Tear Resistance: Provide heavy duty rubber wall and corner guards with a minimum tear resistance of 40N/mn when tested in accordance with BS 903 A3,m method C.
- B. Performance Requirements Traffic Calming and Parking Assist: Provide heavy duty recycled rubber speed calming and parking assist products that conform to the following requires of regulatory agencies and the quality control of Joint Master, InPro Corporation.
 - 1. Density: Provide heavy duty recycled rubber products with a density of 0.6oz/cu in accordance with ASTM C642.
 - 2. Durometer Hardness: Provide heavy duty recycled rubber products with a hardness of 70A ±7 in accordance with ASTM D2240
 - 3. Tensile: Provide heavy duty recycled rubber products with a tensile strength of 300 psi in accordance with ASTM D412
 - 4. Compression Derformation: Provide heavy duty recycled rubber products with a compression deformation of 7% at 70psi, 68°F in accordance with ASTM D575
 - 5. Brittleness: Provide heavy duty recycled rubber products with brittleness at -40°F in accordance

with ASTM D746

6.Weathering: Provide heavy duty recycled rubber products capable of weathering 70 hours at 158°F while maintaining 100% (±5%) of hardness, compressive strength, tensile strength, and elongation in accordance with ASTM D573

1.05 SUBMITTALS

- A. Product Data: Manufacturer's printed product data for each type of protection product specified.
- B. Detail Drawings:
- C. Samples: Verification samples of wall protection, corner guards, speed bump, parking assist in full size profiles of each type indicated.
- D. Manufacturer's Installation Instruction: Printed installation instructions for heavy duty rubber wall protection, corner protection, traffic calming, and parking assist.

1.06 DELIVERY, STORAGE AND HANDLING

- A. Deliver materials in unopened factory packaging to the jobsite
- B. Inspect materials at delivery to assure that specified products have been received.
- C. Store in original packaging in a climate controlled location away from direct sunlight.

1.07 WARRANTY

- A. Wall and Corner Protection: Standard JOINTMASTER Limited Lifetime Warranty against material and manufacturing.
- B. Traffic Calming and Parking Assists: 3 years on rubber and 1 year on tape.

PART 2 - PRODUCTS

2.01 MANUFACTURER

- A. Acceptable Manufacturer/Distributor: JointMaster/InPro Corporation
S80 W18766 Apollo Drive
Muskego, WI 53150 USA;
Telephone: 800-222-5556, Fax: 888-715-8407,
Internet address: <http://www.inprocorp.com>
- B. Substitutions: Not permitted.
- C. Provide all heavy duty rubber wall guards, corner guards; and all heavy duty recycled rubber speed bumps and tire stops from a single source.

2.02 MANUFACTURED UNITS

- A. Wall Guard Profile
 - 1. Heavy Duty EPDM Wall Guard Model number: JOS-Wall200, 8"(203mm) height x 1-1/4"(32mm) depth
 - 2. Heavy Duty EPDM Wall Guard Model number: JOS-Dock075, 3"(76mm) height x 2-13/16"(71mm) depth
 - 3. Heavy Duty EPDM Corner Guard Model number: JOS-Crn075, 3"(78mm) x 3"(78mm) x 39" (1m)
 - 4. Heavy Duty EPDM Corner Guard Model number: JOS-Crn090, 3-1/2"(90mm) x 3-1/2"(90mm) x 39" (1m)
 - 5. Heavy Duty Recycled Rubber Parking Assist Model number: JOS-TrStp1800, 6"(1828mm) length x 6"(154mm) width x 4" (100mm) height.

JOS-TrStp500, 22"(559mm) length, 6"(154mm) width x 4" (100mm) height.

- 6. Heavy Duty Recycled Rubber Speed Bump Model number: JOS-Spd1800, 72"(1828mm) length x 12"(304mm) width x 2-1/4"(57mm) height
- JOS-Spd1200, 48"(1219mm) length x 12"(304mm) width x 2-1/4"(57mm) height.
- JOS-Spde230, 9"(229mm) length x 12"(304mm) width x 2-1/4"(57mm) height.

2.03 MATERIALS

- A. Heavy duty rubber wall guard shall be extruded from UV resistant and ageing resistant ethylene propylene diene monomer (EPDM).
- B. Heavy duty recycled rubber products shall be molded from 100% recycled rubber from car and truck tires (styrene butadiene/ natural rubber blend) with a polyurethane prepolymer for rubber granules

2.04 FINISHES

- A. Heavy Duty Rubber Wall Guards and Corner Guards: Colors of the wall and corner guard shall be black in a uniform quality and free from foreign substances.
- B. Heavy Duty Recycled Rubber Product: Colors of the traffic calming speed bumps and parking assists shall be black in a uniform quality and free of foreign substances, if color is requested (parking assist only) color should be of uniform quality and free of foreign substances

PART 3 - EXECUTION

3.01 EXAMINATION

- A. Examine areas and conditions in which the wall protection will be installed.
 - 1. Complete all finishing operations, including painting, before beginning installation of wall protection materials.
- B. Wall surface shall be dry and free from dirt, grease and loose paint.

3.02 PREPARATION

- A. General: Prior to installation, clean substrate to remove dust, debris and loose particles.

3.03 INSTALLATION

- A. General: Locate product as indicated on the approved detail drawing for the appropriate substrate, and in compliance with the JOINTMASTER installation instructions. Install product level and plumb at the location indicated on the drawings.

3.04 CLEANING

- A. At completion of the installation, clean surfaces in accordance with the JOINTMASTER clean up and maintenance instructions.

IPC.1607/REV.2

Inprocorp.com • 800.222.5556 • 262.679.9010

World Headquarters S80 W18766 Apollo Drive, Muskego, WI 53150 USA

JOINTMASTER™
EXPANSION JOINT SYSTEMS
A DIVISION OF INPRO®