



# Concrete Roof Tiles

**NORTHERN CALIFORNIA** STANDARD WEIGHT COLLECTION



# Concrete Roof Tiles

Few roof products are as beautiful or enduring as Boral concrete roof tiles. With so many styles and colors to choose from, you'll find that adding a tile roof to your home is one of the easiest and most effective ways to complement its look and increase its value.

Tile.

For the way it looks.

And the way it lasts.



Natural  
& Extensive  
Color Offering





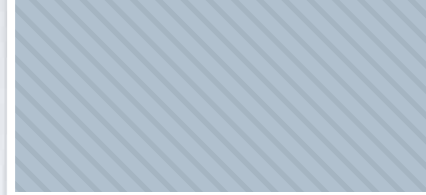
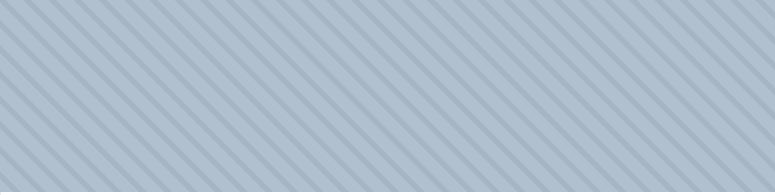

## Tile is timeless

Only tile enables you to achieve authentic, old-world aesthetics with the benefits of durable, modern materials. Boral Roofing has captured all the characteristics of natural slate, clay and wood – which are historically the world’s most widespread roofing materials – in a concrete tile. The result is a tile roof of unmatched beauty and a home with incredible curb appeal.

Boral Roofing is continually acknowledged by the industry for our product innovations. And three of our most popular products - Madera, Slate and Barcelona - replicate authentic materials, while reducing installation costs and increasing longevity and energy efficiency.



**In Stock**  Our most popular colors as chosen by you, our customer. Products noted as In Stock are our most readily available colors, please check with your local Sales Representative for current tile availability.

**Code Approval:** Complies with all building codes including but not limited to ICC ESR-1647. Some approvals are regional and only apply to locally produced products; please contact Boral Roofing before transporting product across state lines. Specifically, products used in the Miami Dade County region of Florida require special testing and recognition. All tiles are Class A fire rated.

**Disclaimer:** The printed colors shown in this brochure may vary from actual available tile colors. Before making a final selection, be sure to review actual tile samples and roof installations. Please contact your local sales office for further assistance. Categories, typographical errors subject to change without notice. No performance guarantee is offered or implied beyond that expressly indicated.

Efflorescence is a temporary surface condition which is common to all concrete products. The process is caused by the chemical nature of cement. This reaction can appear as an overall chalky white bloom (a softening of color) or in more concentrated patches. It is difficult to predict how long the effects of efflorescence will last. It depends on the type and amount of deposit as well as local weather conditions. The action of carbon dioxide and rainwater will gradually remove the deposit, in most cases, leaving the original color of the roof intact without further efflorescence occurring. It is superficial and in no way affects the quality or functional properties of the tile.

**Installation:** Please consult the Tile Roofing Institute (TRI) Installation guides for application recommendations.

# Barcelona 900

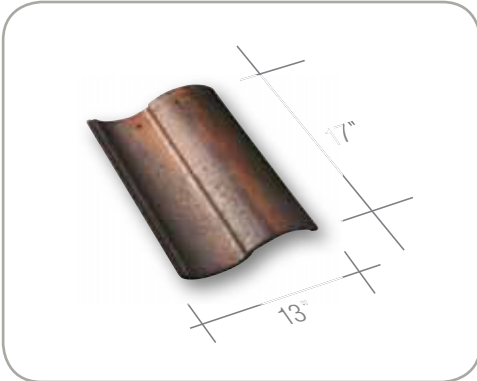

Barcelona 900 is designed to reflect the classic style and distinctiveness of Spanish architecture, popular in the early California missions that stretched from Santa Barbara to San Juan Capistrano.

- Classic style with the durability and value of concrete tile
- Distinct hue combinations that create a beautiful, rustic appearance

Coverage	Installed Weight / Square
At 3" minimum headlap, 85 field tiles will cover approx. 100 square feet of roof area.	Approx. 930 lbs.



Choose from one of our many cool roof rated tiles that will improve the energy efficiency by reflecting sunlight and heat away from your roof. When these are combined with our Elevated Batten System, they will provide reduced cooling costs and they may even qualify for local rebates. The Cool Roof Rating Council (CRRC) measures the "coolness" of a roof by determining a roof's solar reflectance (SR) and thermal emittance (TE). Both properties are rated on a scale from 0 to 1, where 1 is the most reflective or emissive. The CRRC measures these two properties for roofing products, both for the product's initial values and after three years of weather exposure. Boral Roofing manufactures products that meet CRRC guidelines, allowing homeowners in some regions to receive utility rebates. Boral Roofing's CRRC rated products help reduce the heat island effect found in urban areas and in general, increases the overall energy efficiency of the building. For current product ratings please visit our website at [www.boralna.com](http://www.boralna.com) and click on CRRC logo on the home page.



**Brown Blend**

1HBCS3233



CRRC ID# – 0942-0003  
Ref: 0.20 / Emi: 0.91 / SRI: 19 / Aged Ref: 0.20

**Terra Cotta Flashed**

1HBCS6300



CRRC ID# – 0942-0018  
Ref: 0.19 / Emi: 0.91 / SRI: 18 / Aged Ref: 0.19

**Verona Clay**

1HBCS7330



CRRC ID# – 0942-0004  
Ref: 0.20 / Emi: 0.93 / SRI: 20 / Aged Ref: 0.20

**California Mission Blend**

1HBCS6464



CRRC ID# – 0942-0008  
Ref: 0.19 / Emi: 0.91 / SRI: 18 / Aged Ref: 0.19

**Rio Grande Blend**

1HBCS6142



CRRC ID# – 0942-0057  
Ref: 0.23 / Emi: 0.93 / SRI: 24 / Aged Ref: 0.22

**Salerno Clay**

1HBCS6330



CRRC ID# – 0942-0012  
Ref: 0.17 / Emi: 0.93 / SRI: 17 / Aged Ref: 0.18

**Apple Bark**

1HBCS0431



CRRC ID# – 0942-0007  
Ref: 0.18 / Emi: 0.90 / SRI: 16 / Aged Ref: 0.19

**Casa Grande Blend**

1HBCS6169



CRRC ID# – 0942-0014  
Ref: 0.23 / Emi: 0.91 / SRI: 23 / Aged Ref: 0.22

**Gulfstream**

1HBCS4960



CRRC ID# – 0942-0013  
Ref: 0.21 / Emi: 0.91 / SRI: 21 / Aged Ref: 0.21

# Barcelona 900

## Goldenrod

1HBCS6116

NEW



CRRC ID# - 0942-0043  
Ref: 0.32 / Emi: 0.89 / SRI: 34 / Aged Ref: 0.28

## Charleston

1HBCS6070

NEW



CRRC ID# - 0942-0073  
Ref: 0.29 / Emi: 0.87 / SRI: 29 / Aged Ref: 0.26

## Dunes Tan

1HBCS0198

NEW



CRRC ID# - 0942-0074  
Ref: 0.29 / Emi: 0.89 / SRI: 30 / Aged Ref: 0.26





# Boosted Barcelona Caps



### Installed Weight / Square

- 10% - Approx. 9 caps per sq. 940 - 950 lbs.
- 20% - Approx. 18 caps per sq. 980 - 1000 lbs.
- 30% - Approx. 27 caps per sq. 1020 - 1050 lbs.

Boosted Barcelona Caps is an available installation application when combined with Barcelona 900 field tiles, replicates the appearance of an authentic mortar-boosted tile.

- Available in colors that emulate the warm, rustic tones of natural clay
- Superior manufacturing techniques make Boosted Barcelona Caps simple to install – reducing installation costs

Boosted Barcelona Caps is an available application of Barcelona 900 tile and should be installed with Barcelona 900 field tile.

### Brown Blend

1BLCS3233K



CRRC ID# – 0942-0003  
Ref: 0.20 / Emi: 0.91 / SRI: 19 / Aged Ref: 0.20

### California Mission Blend

1BLCS6464K



CRRC ID# – 0942-0008  
Ref: 0.19 / Emi: 0.91 / SRI: 18 / Aged Ref: 0.19

### Casa Grande Blend

1BLCS6169K



CRRC ID# – 0942-0014  
Ref: 0.23 / Emi: 0.91 / SRI: 23 / Aged Ref: 0.22

### Salerno Clay

1BLCS6330K



CRRC ID# – 0942-0012  
Ref: 0.17 / Emi: 0.93 / SRI: 18 / Aged Ref: 0.18



# Villa 900

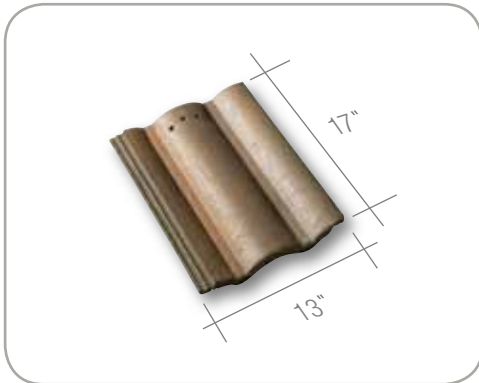

Villa 900 emulates the most popular tile in the world faithfully re-creating the beautiful Mediterranean style popular in Italy and Southern France.

- Unique colors and blends can enhance any architectural theme
- Superior strength and durability of concrete tile

Coverage	Installed Weight / Square
At 3" minimum headlap, 87 field tiles will cover approx. 100 square feet of roof area.	Approx. 930 lbs.





**Pueblo Sienna Blend**

1VICS5537



**Salerno Clay**

1VICS6330



CRRC ID# – 0942-0012  
Ref: 0.17 / Emi: 0.93 / SRI: 17 / Aged Ref: 0.18

**Verona Clay**

1VICS7330



CRRC ID# – 0942-0004  
Ref: 0.20 / Emi: 0.93 / SRI: 20 / Aged Ref: 0.20

**Desert Sage**

1VICS0024



CRRC ID# – 0942-0022  
Ref: 0.27 / Emi: 0.93 / SRI: 29 / Aged Ref: 0.25

**Camino Blend**

1VICS3163



CRRC ID# – Pending  
Ref: 0.20 / Emi: 0.87 / SRI: 17 / Aged Ref: 0.20

**Casa Grande Blend**

1VICS6169



CRRC ID# – 0942-0014  
Ref: 0.23 / Emi: 0.91 / SRI: 23 / Aged Ref: 0.22

**Brown Blend**

1VICS3233



CRRC ID# – 0942-0003  
Ref: 0.20 / Emi: 0.91 / SRI: 19 / Aged Ref: 0.20

**Gulfstream**

1VICS4960



CRRC ID# – 0942-0013  
Ref: 0.21 / Emi: 0.91 / SRI: 21 / Aged Ref: 0.21

**California Mission Blend**

1VICS6464



CRRC ID# – 0942-0008  
Ref: 0.19 / Emi: 0.91 / SRI: 18 / Aged Ref: 0.19

# Villa 900™

## Charleston

1VICS6070

NEW



CRRC ID# - 0942-0073  
Ref: 0.29 / Emi: 0.87 / SRI: 29 / Aged Ref: 0.26

## Sedona Gold - Slurry Finish

1VISS6566



CRRC ID# - 0942-0026  
Ref: 0.44 / Emi: 0.92 / SRI: 51 / Aged Ref: 0.37

## Dunes Tan

1VICS0198

NEW



CRRC ID# - 0942-0074  
Ref: 0.29 / Emi: 0.89 / SRI: 30 / Aged Ref: 0.26

## Marbled Terra Cotta

1VICS6129



CRRC ID# - 0942-0020  
Ref: 0.19 / Emi: 0.91 / SRI: 18 / Aged Ref: 0.19

## Goldenrod

1VICS6116

NEW



CRRC ID# - 0942-0043  
Ref: 0.32 / Emi: 0.89 / SRI: 34 / Aged Ref: 0.28



 In Stock



*Villa Goldenrod*





# Saxony® 900 Hartford® Slate

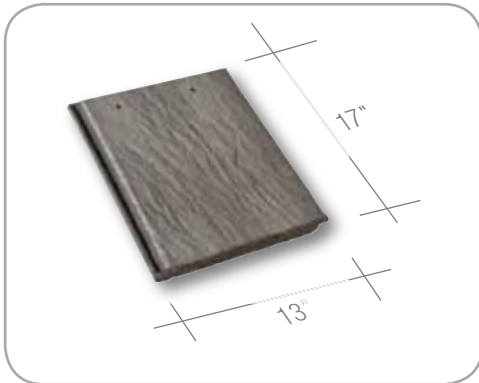

Hartford Slate receives a surface texture designed to emulate the surface of natural slate. Natural slate is the traditional roofing material used for homes in the Eastern States, Great Britain and Northern Europe.

Coverage	Installed Weight / Square
At 3" minimum headlap, 85 field tiles will cover approx. 100 square feet of roof area.	Approx. 910 lbs.





**Stone Mountain Blend**

1FVCD5354



CRRC ID# - 0942-0047  
Ref: 0.17 / Emi: 0.90 / SRI: 15 / Aged Ref: 0.18

**Charcoal Brown Blend**

1FVCD1132



CRRC ID# - 0942-0005  
Ref: 0.18 / Emi: 0.91 / SRI: 17 / Aged Ref: 0.19

**Toffee**

1FVCD0007



CRRC ID# - 0942-0001  
Ref: 0.15 / Emi: 0.93 / SRI: 14 / Aged Ref: 0.17

**Forest Green**

1FVCD4598



CRRC ID# - 0942-0005  
Ref: 0.20 / Emi: 0.93 / SRI: 20 / Aged Ref: 0.20

**Appalachian Blend**

1FVCD0330



CRRC ID# - 0942-0069  
Ref: 0.14 / Emi: 0.89 / SRI: 11 / Aged Ref: 0.16

**Cherrywood**

1FVCD7002



CRRC ID# - 0942-0006  
Ref: 0.19 / Emi: 0.91 / SRI: 18 / Aged Ref: 0.19



# Saxony® 900 Split Old English Thatch

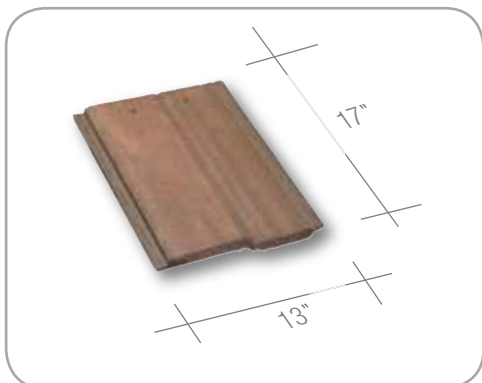

Split Old English Thatch combines the look of a natural slate with the varied appearance of a hand-hewn split tile capturing the charming architecture of an old English countryside

Saxony Split Old English Thatch should be applied in a random, broken-bond with a minimum 3" offset between the sidelaps of adjacent courses. Sidelaps in alternate courses shall not be in direct alignment.

Coverage	Installed Weight / Square
At 4" minimum headlap, 91 field tiles will cover approx. 100 square feet of roof area.	Approx. 980 lbs.



*Split Old English Thatch Cliffside*



*Split Old English Thatch Autumnwood*





**Autumnwood**

1FOCZ3002



CRRC ID# – 0942-0070  
Ref: 0.13 / Emi: 0.87 / SRI: 8 / Aged Ref: 0.15

**Charcoal**

1FOCZ1130



CRRC ID# – 0942-0064  
Ref: 0.08 / Emi: 0.92 / SRI: 5 / Aged Ref: 0.12

**Cliffside**

1FOCZ3940



CRRC ID# – 0942-0017  
Ref: 0.16 / Emi: 0.91 / SRI: 14 / Aged Ref: 0.17

**Toffee**

1FOCZ0007



CRRC ID# – 0942-0001  
Ref: 0.15 / Emi: 0.93 / SRI: 14 / Aged Ref: 0.17

**Vintagewood**

1FOCZ5011



CRRC ID# – 0942-0089  
Ref: 0.12 / Emi: 0.94 / SRI: 11 / Aged Ref: 0.14

**Buckskin**

1FOCZ0141



CRRC ID# – 0942-0009  
Ref: 0.22 / Emi: 0.90 / SRI: 22 / Aged Ref: 0.21



## Saxony® 900 Slate

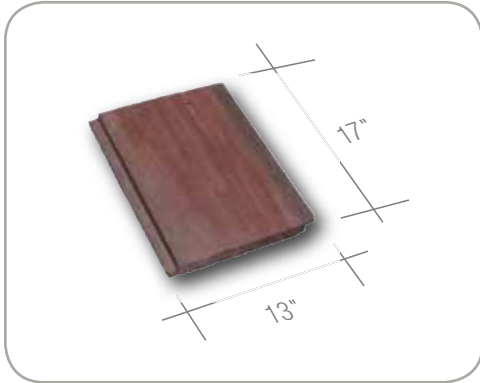

This beautiful design is representative of the roof styles found in England, Northern Europe and the Eastern Seaboard; and is versatile enough to accentuate any architectural style.

Available in a broad range of colors, it faithfully captures the appearance of natural slate.

Coverage	Installed Weight / Square
At 3" minimum headlap, 85 field tiles will cover approx. 100 square feet of roof area.	Approx. 910 lbs.

*Slate Stone Mountain Blend*





**Charcoal Brown Blend**

1FACS1132



CRRC ID# – 0942-0005  
Ref: 0.18 / Emi: 0.91 / SRI: 17 / Aged Ref: 0.19

**California Mission Blend**

1FACS6464



CRRC ID# – 0942-0008  
Ref: 0.19 / Emi: 0.91 / SRI: 18 / Aged Ref: 0.19

**Charcoal**

1FACS1130



CRRC ID# – 0942-0064  
Ref: 0.08 / Emi: 0.92 / SRI: 5 / Aged Ref: 0.12

**Desert Sage**

1FACS0024



CRRC ID# – 0942-0022  
Ref: 0.27 / Emi: 0.93 / SRI: 29 / Aged Ref: 0.25

**Cherrywood**

1FACS7002



CRRC ID# – 0942-0006  
Ref: 0.19 / Emi: 0.91 / SRI: 18 / Aged Ref: 0.19

**Stone Mountain Blend**

1FACS5354



CRRC ID# – 0942-0047  
Ref: 0.17 / Emi: 0.90 / SRI: 15 / Aged Ref: 0.18

**Appalachian Blend**

1FACS0330



CRRC ID# – 0942-0069  
Ref: 0.14 / Emi: 0.89 / SRI: 11 / Aged Ref: 0.16

**Newport Sun**

1FACS6953



CRRC ID# – 0942-0111  
Ref: 0.31 / Emi: 0.90 / SRI: 33 / Aged Ref: 0.28

**Natural Marble**

1FACS5037



CRRC ID# – 0942-0048  
Ref: 0.20 / Emi: 0.90 / SRI: 19 / Aged Ref: 0.20

# Saxony® 900 Slate

## Dunes Tan

1FACS0198

NEW



CRRC ID# - 0942-0074  
Ref: 0.29 / Emi: 0.89 / SRI: 30 / Aged Ref: 0.26

## Charleston

1FACS6070

NEW



CRRC ID# - 0942-0073  
Ref: 0.29 / Emi: 0.87 / SRI: 29 / Aged Ref: 0.26

## Goldenrod

1FACS6116

NEW



CRRC ID# - 0942-0043  
Ref: 0.32 / Emi: 0.89 / SRI: 34 / Aged Ref: 0.28

## Brookside Rosewood Blend

1FACS0212



CRRC ID# - Pending  
Ref: 0.21 / Emi: 0.93 / SRI: 21 / Aged Ref: 0.21

Slate California Mission Blend







*Slate Charcoal*



# Saxony® 900 Shake

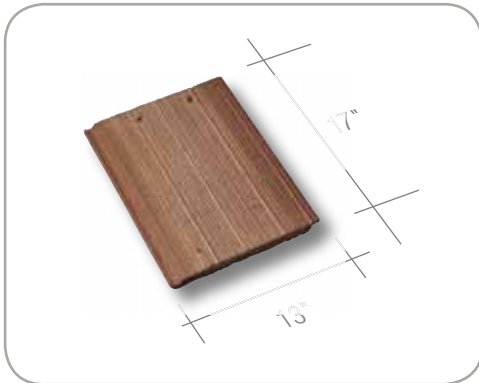

Saxony Shake roof tile perfectly captures the rustic warmth and beauty of country living by recreating the look of hand-hewn shakes. Ideal for French Country, Victorian Craftsman or Cottage architectural styling, these home designs can be enhanced with the diverse color spectrum of the Saxony Shake Collection.

Coverage	Installed Weight / Square
At 3" minimum headlap, 85 field tiles will cover approx. 100 square feet of roof area.	Approx. 910 lbs.





**Cedar Blend**

1FBCF3293



CRRC ID# – 0942-0071  
Ref: 0.17 / Emit: 0.90 / SRI: 15 / Aged Ref: 0.15

**Dove Brown II**

1FBCF3152



**Shadow Grey**

1FBCF5225



**Charcoal Brown Blend**

1FBCF1132



CRRC ID# – 0942-0005  
Ref: 0.18 / Emit: 0.91 / SRI: 17 / Aged Ref: 0.19

**Kocomo Blend**

1FBCF3763



**Dark Ash**

1FBCF5139

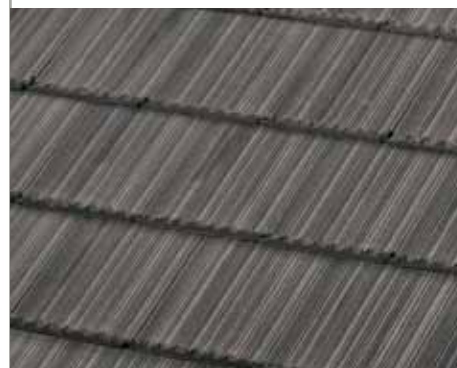

**Shadow Brown**

1FBCF3214



CRRC ID# – 0942-0077  
Ref: 0.17 / Emit: 0.92 / SRI: 16 / Aged Ref: 0.18

**Brown Blend**

1FBCF3233



CRRC ID# – 0942-0003  
Ref: 0.20 / Emit: 0.91 / SRI: 19 / Aged Ref: 0.20

**Charcoal Blend**

1FBCF1430



CRRC ID# – 0942-0072  
Ref: 0.17 / Emit: 0.91 / SRI: 16 / Aged Ref: 0.18

**Toffee**

1FBCF0007



CRRC ID# – 0942-0001  
Ref: 0.15 / Emi: 0.93 / SRI: 14 / Aged Ref: 0.17

**Hickory**

1FBCF3726



CRRC ID# – 0942-0065  
Ref: 0.15 / Emi: 0.93 / SRI: 14 // Aged Ref: 0.17

**Sienna Blend**

1FBCF6614



CRRC ID# – 0942-0082  
Ref: 0.16 / Emi: 0.88 / SRI: 13 / Aged Ref: 0.17

**Charleston**

1FBCF6070

NEW



CRRC ID# – 0942-0073  
Ref: 0.29 / Emi: 0.87 / SRI: 29 / Aged Ref: 0.26

**Dunes Tan**

1FBCF0198

NEW



CRRC ID# – 0942-0074  
Ref: 0.29 / Emi: 0.89 / SRI: 30 / Aged Ref: 0.26



 In Stock

The printed colors shown in this brochure may vary from actual available tile colors.







# Madera 900

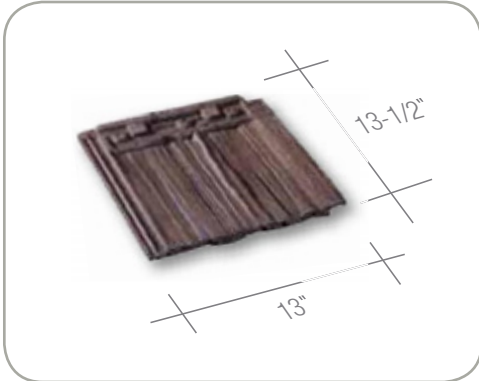

Madera 900 is the most affordable, authentic replication of a hand-split cedar shake roof available. With its realistic wood shake surface, Madera 900 will complement any architectural style.

Coverage	Installed Weight / Square
At 3-1/2" minimum headlap, 120 field tiles will cover approx. 100 square feet of roof area.	Approx. 950 lbs.

**Mountainwood**  
1MDCL5001

CRRC ID# - 0942-0110  
Ref: 0.08 / Emi: 0.93 / SRI: 5 / Aged Ref: 0.12

**Autumnwood**  
1MDCL3002

CRRC ID# - 0942-0070  
Ref: 0.13 / Emi: 0.87 / SRI: 8 / Aged Ref: 0.15

**Vintagewood**  
1MDCL5011

CRRC ID# - 0942-0089  
Ref: 0.12 / Emi: 0.94 / SRI: 11 / Aged Ref: 0.14



 In Stock

The printed colors shown in this brochure may vary from actual available tile colors.











# Finishing Touches

Boral Roofing provides all of the necessary products for a durable and beautiful roof installation. Our trim tile is the most efficient and attractive way to complete your roof. In addition to rake and ridge pieces, Boral Roofing manufactures hip starters and apex tiles that ease installation. All are protected by our Limited Lifetime, Fully Transferable, Non-Prorated Product Warranty for tile.

- Precision production techniques provide a consistent look throughout the project
- Colors and textures complement field tile; no need to mix color mortar
- Easier and faster to install than mortar balls; no second steps
- Reduces labor time and expense

## Barcelona 900



Capri Trim



Capri Hip Starter



Capri Apex 3-Way



## Villa 900



Capri Trim



Capri Hip Starter



Capri Apex 3-Way



## Saxony® 900

Hartford® Slate  
Split Old English Thatch  
Slate  
Shake



90° Rake



3-Sided Ridge



3-Sided Hip Starter



Apex 3-Way



Apex 4-Way



## Madera 900



90° Rake



V-Ridge



Tapered Eave Starter



# Roof System Components

At Boral we view a roof as not a mere tile covering but a dynamic, performing system that protects, breathes and ages with the structure. By studying roof performance characteristics and failure points, we have created Roof System Components – a collection of components that, when installed properly and used comprehensively, result in a tile roof that lasts longer and increases energy savings.

- Ensures all areas of a roof are protected and utilized for optimum performance
- Improves weatherproofing and “breathability” of a tile roof
- Helps prevent water damage
- Increases airflow and ventilation
- Provides aesthetically pleasing design elements

When used together, selected products form Boral’s Energy Efficient Roof System further reinforcing our belief that we must strive to perfect not only a roof’s aesthetic form, but also its primary function. Only then can we provide our customers with a roofing solution unmatched by any other roofing company.

## How much could you save?

### Vents

It is estimated 75% of homes have deficient attic ventilation, which increases energy costs and diminishes the lifespan of roofing underlayments. These products ensure proper ventilation and help reduce energy costs.

### Hip & Ridge

Hips and ridge weather blocking helps prevent wind-driven rain, snow and other debris from entering the peaks and corners of a roof, and increases ventilation.

### Valleys

Channeling water properly helps prevent it from collecting on the deck – which can damage the underlayment and cause the roof deck and underlying structure to rot.

### Fasteners and Tools

While standard roofing nails are typically used according to local code requirements, Boral recommends premium fasteners and tools that offer added performance and security.

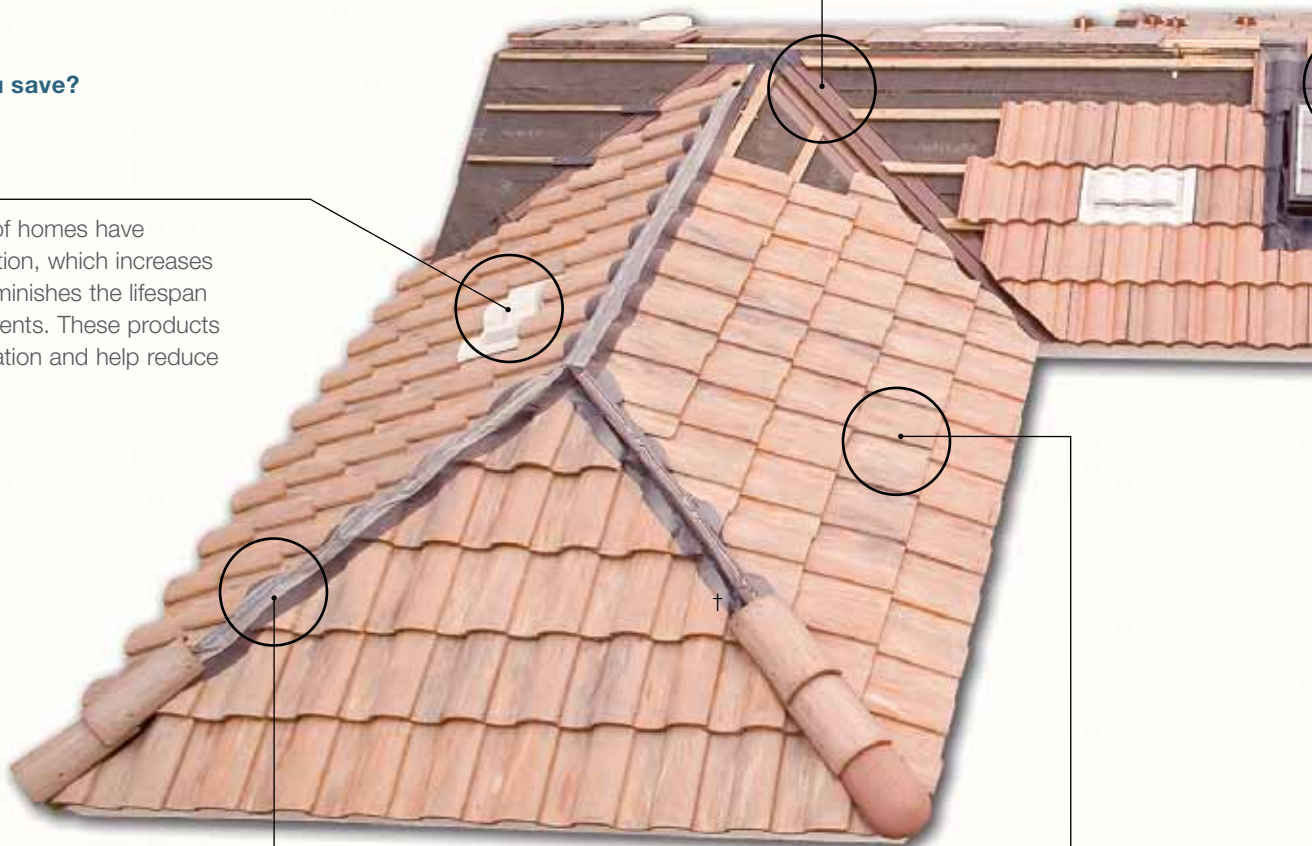



## Flashing

Proper flashings prevent water, snow and debris from entering joints where the walls meet the roof deck. The use of flashing creates the proper barrier in this situation.

## Underlayments

While tile is ultimately the first line of defense against the elements, underlayments provide a secondary level of protection directly on top of the roof deck from deterioration, moisture and leaks.

## Eaves

Proper eave treatment creates a finished look for the roof and enhances its overall functionality. By elevating the first course of tile to the proper height, it completes the overall aesthetic of the roof, and protection against infestation.

## Battens

Our Elevated Battens are a crucial aspect of Boral's Energy Efficient Roof System, and improve the performance of any tile installation. They provide positive anchoring for each tile, raising each tile off the roof deck to provide ventilation and the unrestricted flow of any moisture on the underlayment.

## Rake & Gable End

Boral's alternative to rake tiles provide aesthetic options and protection against weather, animal infestation and debris accumulation.



# Energy Efficient Roof System

## Why should you choose Boral's Energy Efficient Roof System? Highly Energy Efficient and Long Lasting.

### How does it work?



Tile roofs are highly insulating and prevent much of the sun's heat from penetrating the building. Boral offers tiles in a wide range of profiles in highly reflective colors and certain tiles meet Energy Star and U.S. Green Building Council's LEED (Leadership in Energy and Environmental Design) rating.

In addition to tile's thermal mass, the air space between the tile and the roof deck provides a layer of insulation. Boral Roof Tiles goes a step further by naturally ventilating this air space. Nearly all the heat that penetrates through the tiles is vented through the ridge. This keeps the building cooler, reducing your energy bills every year with no electrical or mechanical parts. Letting your roof system breathe will also make it last longer than traditional tile roof construction.



The most common reason for reroofing is deterioration of the roof system beneath the tiles when tiles or flashings are damaged or installed incorrectly.

Boral roof systems allow moisture that may get under the tiles or flashings to flow down and off the roof deck and quickly dry out, keeping the roof system in good condition to last longer.

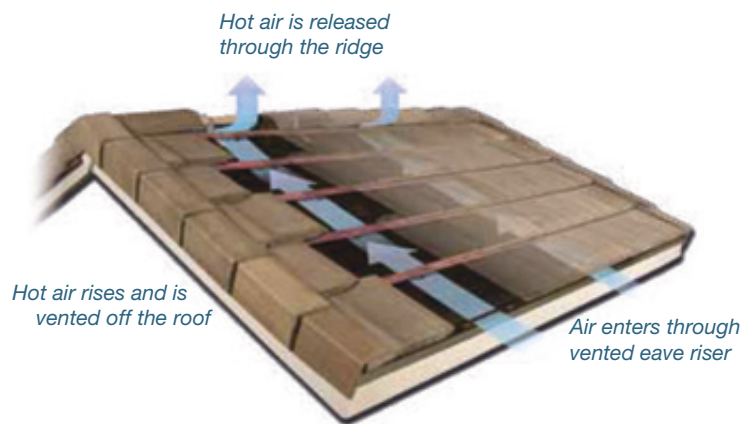

### How much could you save?



A family in a typical single family house could save up to 22% per year on heating and cooling costs compared to the standard asphalt shingle roof.\* A single family house with a Boral's Energy Efficient Roof System could save an average of \$15 to \$20 per month immediately compared to a standard asphalt shingle roof and as energy rates rise year over year, your savings could increase as well and could amount up to \$20,000 over 30 years.\*\*

Calculate how much you could save by visiting [www.monierlifetile.com](http://www.monierlifetile.com) and clicking on the Energy Calculator button.

Asphalt Shingle Roof	BORAL Concrete Tile Roof with Energy Efficient Roof System
Attic Space <b>139°</b> †	Attic Space <b>94°</b> †
High Cooling Needs Higher Energy Bill	Less Cooling Needs Lower Energy Bill

**Up to Approximately \$20,000 in savings over 30 years\*\***

† Temperatures measured in simulated attics using identical heat sources simulating sun's radiation to compare Boral's Energy Efficient Roof System to common asphalt shingle roof system.

\*Steep-slope Assembly Testing of Clay and Concrete Tile with and without Cool Pigmented Colors, Oak Ridge National Laboratory, 2005. Results vary based on profile of tile installed, location, weather and other factors.

\*\*Results based on a 22 square roof in Southern California with no additional energy efficient upgrades during an average annual weather pattern, annual inflation rate of 3%, and annual energy cost increase of 3.5%. Savings may vary based on location, weather and other factors. Savings estimates are based on comparison to similar size asphalt shingle roof.



## Eco-Responsible

### HIGHLY ENERGY EFFICIENT ROOF SYSTEM COMBINING EARTH FRIENDLY MATERIALS WITH ENERGY STAR RATED ROOF TILES

Energy Star rated roof tiles combined with innovative roof ventilation provide a highly energy efficient roof system. Eco-friendly materials such as concrete or clay, sustainably harvested wood and recycled materials are used to build a system that will last longer. The Elevated Batten System™ combined with StrongSeal® recycled tire rubber underlayment provides superior protection against leaks and contains no asphalt.



## Premium

### A SUPERIOR SYSTEM WITH BETTER PROTECTION AGAINST THE ELEMENTS AND SIGNIFICANT ENERGY SAVINGS\*

Premium quality components and construction methods provide superior durability and energy efficiency.\* The Elevated Batten System™ provides natural air insulation and ventilation while eliminating thousands of perforations through the water proofing underlayment. Boral TileSeal® underlayment has a cool white surface and adheres to the deck without nails or staples for better protection against leaks.



## Contractor's Choice

### AFFORDABLE SYSTEM FOR THE COST-CONSCIOUS

This is an affordable energy saving\* roof with better quality and more security than the code minimum standard. This system upgrades a few code required components to create a roof that breathes with the innovative roof ventilation developed by Boral Roofing along with a durable, high performance underlayment at a modest price.



#### Vented Ridge

- Provides weather protection at hips and ridges
- Exhausts heated air from under the tiles
- Also can ventilate the attic

#### Underlayment

- High quality protection from the elements as a secondary water proof barrier under tiles
- Underlayments sold by Boral Roofing are backed by a manufacturer's limited warranty

#### Concrete Tile

- Highly efficient material due to high thermal mass and insulating air space beneath the tiles
- Class A fire rated
- Resistant to rain, snow, hail, fire, noise and high winds - see our Warranty for details\*

#### Vented Eave Riser

- Made to fit the first row of tiles and raise them to proper height
- Provides intake of air for ventilation under the roof tiles
- Profiled styles are decorative and functional

#### Elevated Batten System™ (EBS)

- Elevates tiles to allow free flow of air and water
- Provides effective thermal barrier and ventilation

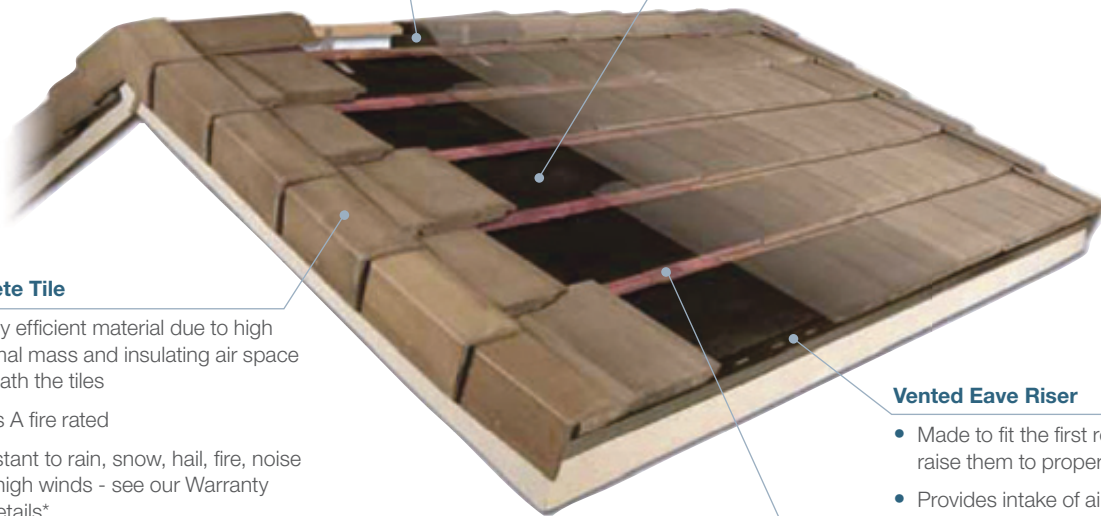

## Corporate Office

### **Boral Roofing**

200 Mansell Court East, Suite 310  
Roswell, GA 30076

## Western Office

### **Boral Roofing**

7575 Irvine Center Drive, Ste. #100  
Irvine, CA 92618  
949 756 1605

## Customer Service

800 571 TILE (8453)

### ABOUT BORAL ROOFING

Boral Roofing is a division of Boral USA, the country's largest premium provider of complete roofing and re-roofing solutions for architects as well as commercial and residential builders. Boral Roofing, which includes US Tile and MonierLifetile, operates 15 clay and concrete tile manufacturing plants throughout the US and Mexico.

### ABOUT BORAL USA

Headquartered in Roswell, Georgia, Boral USA through its subsidiaries employs approximately 1,500 individuals at more than 140 operating and distribution sites across the United States. The U.S. operations include the country's largest brick manufacturer and the largest clay and concrete roof tile manufacturer.



## Sales Offices

**Phoenix, ARIZONA**

**Corona, CALIFORNIA**

**Gilroy, CALIFORNIA**

**Lathrop, CALIFORNIA**

**Stockton, CALIFORNIA**

**Rialto, CALIFORNIA**

**Denver, COLORADO**

**Pompano Beach, FLORIDA**

**Lake Wales, FLORIDA**

**Atlanta, GEORGIA**

**Kapolei, HAWAII**

**Kansas City, MISSOURI**

**Henderson, NEVADA**

**Katy, TEXAS**

**Tacoma, WASHINGTON**

[www.boralna.com](http://www.boralna.com)



Download a QR Code reader app for your smartphone, then take a photo to visit our website.



The Boral Logo is a trade mark of Boral Limited or its affiliates and may be registered in many jurisdictions worldwide.

