

# **bp** Glass Garage Doors

## **The Architects' Choice**

- High Strength Extrusions
- Custom Powder Coated Finishes
- Custom Tapered Sections
- Custom Glazing Options
- Custom Fabrication

**TOLL FREE**

**877-442-1716**

**bp** Bryce Parker Co. LIC # 750084



Phone: 626-442-1716 Fax: 626-579-5320  
www.GlassGarageDoors.com

9412 Gidley Street, Temple City, CA 91780  
Email: Service@bpcompany.net



# Overhead Door Checklist

(For Architects & Contractors)

The following checklist has been designed by Bryce Parker Company to assist Architects & Contractors with important design characteristics of an All Glass Garage Door. Diagrams have been provided (See Attachments) to illustrate key areas of focus. Should additional assistance be necessary, please contact us Toll Free (877) 442-1716.

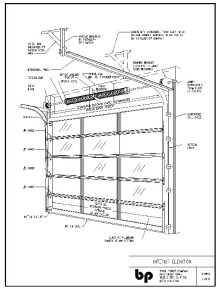

## Interior Elevation - (See Diagram #1 of 5)

Use this illustration to identify the following key design characteristics:

- Spring Pad (centered above header and made of solid backing; steel, concrete, or wood)
- Torsion Bar, Spring Assembly & Bearing Plates (fastened to spring pad and continuous jamb)
- Vertical & Horizontal Track (may not be obstructed in any way from floor to ceiling)
- Electric Operators Supply (1ea. 120v x 20 amp. receptacle mounted & located as per dia. #2 of 5)
- Back Hangers (supported above track from solid backing in ceiling, such as rafters)

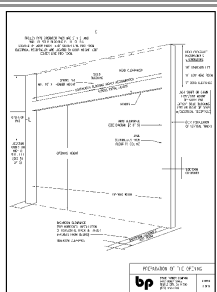

## Preparation of the Opening - (See Diagram #2 of 5)

Cross-reference your door opening with this diagram to note the following:

- Check that the header is flush with the jambs (Both should be on the same vertical plane)
- Available Head Clearance (of solid backing): \_\_\_\_\_ ft. \_\_\_\_\_ in. (Provide info to BP Co.)
- Available Jamb Clearance (of solid backing): \_\_\_\_\_ ft. \_\_\_\_\_ in. (Provide info to BP Co.)
- Opening Height: \_\_\_\_\_ ft. \_\_\_\_\_ in. (Provide info to BP Co.)
- Opening Width: \_\_\_\_\_ ft. \_\_\_\_\_ in. (Provide info to BP Co.)
- Side Clearance: \_\_\_\_\_ ft. \_\_\_\_\_ in. (Should not be obstructed ex. cabinets)
- Backroom Clearance (into room): \_\_\_\_\_ ft. \_\_\_\_\_ in. (Should not be obstructed ex. Cabinets)

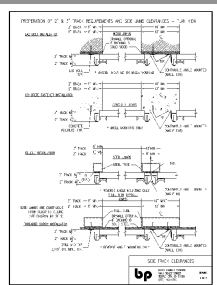

## Side Track Clearances - (See Diagram #3 of 5)

This page is mainly to illustrate the importance of the jamb area with regards to mounting the track. The additional weight of an all glass or aluminum sectional door must be supported properly by one of the following jamb types: (choose jamb type)

- Wood Jambs
- Concrete Jambs
- Steel Jambs
- Concrete & Steel Jambs

Note: It is acceptable for any of these jamb types to have drywall.

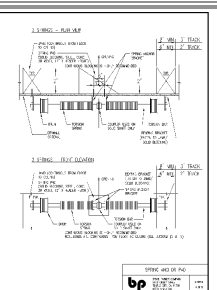

## Spring Anchor Pad Preparation - (See Diagram #4 of 5)

It is important to have solid backing in the header for the spring & electric operator assembly (including zero clearance installations). Since the number of springs and their configuration are determined at installation, it is important to design the spring pad for multiple configurations. The spring pad has a minimum requirement of 12" wide x Header Height (See Preparation Of The Opening Diagram #2). However, we recommend that you design a continuous spring pad (such as a structural header from jamb to jamb) to allow for multiple configurations.

- Spring Anchor Pad

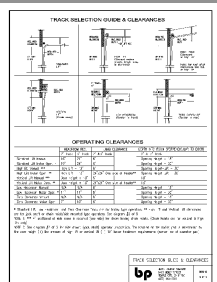

## Track Selection Guide - (See Diagram #5 of 5)

Using the information from Diagram #2 (Preparation of the Opening), you will be able to determine the appropriate track type for your opening.

- Standard Lift
- High Lift
- Roof Pitch
- Vertical Lift
- Low Headroom
- Zero Clearance

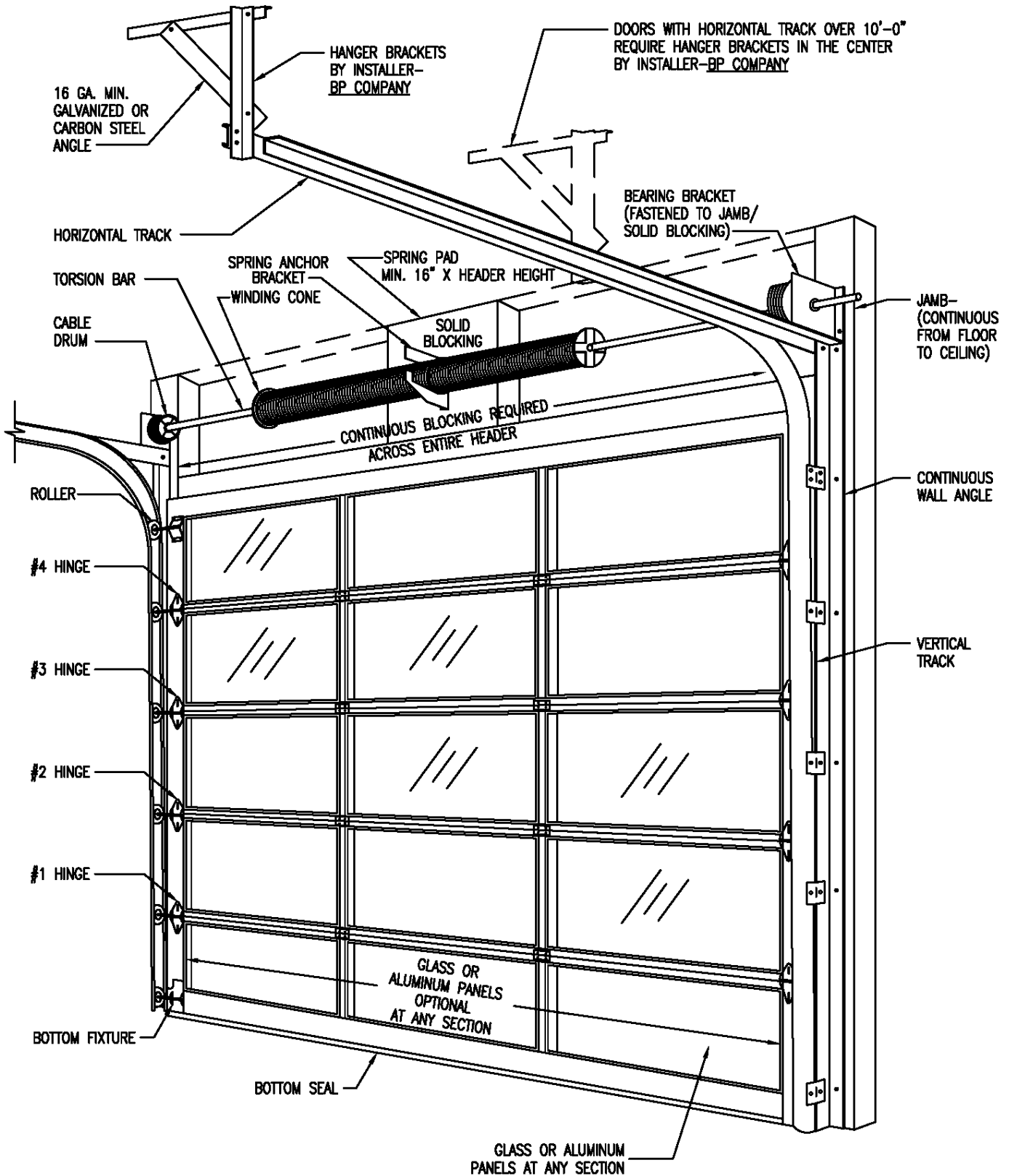

INTERIOR ELEVATION



BRYCE PARKER COMPANY  
 9412 GIDLEY STREET  
 TEMPLE CITY, CA 91780  
 (877) 442-1716

DRAWING  
 1 OF 5

TROLLEY TYPE OPERATOR PADS ARE 2' X 2' AND  
 MADE OF SOLID BLOCKING IN THE CEILING  
 LOCATED BY DOOR HEIGHT +30" CENTER LINE INTO ROOM  
 ELECTRICAL RECEPTACLES ARE LOCATED BY DOOR HEIGHT +36"  
 CENTER LINE INTO ROOM.

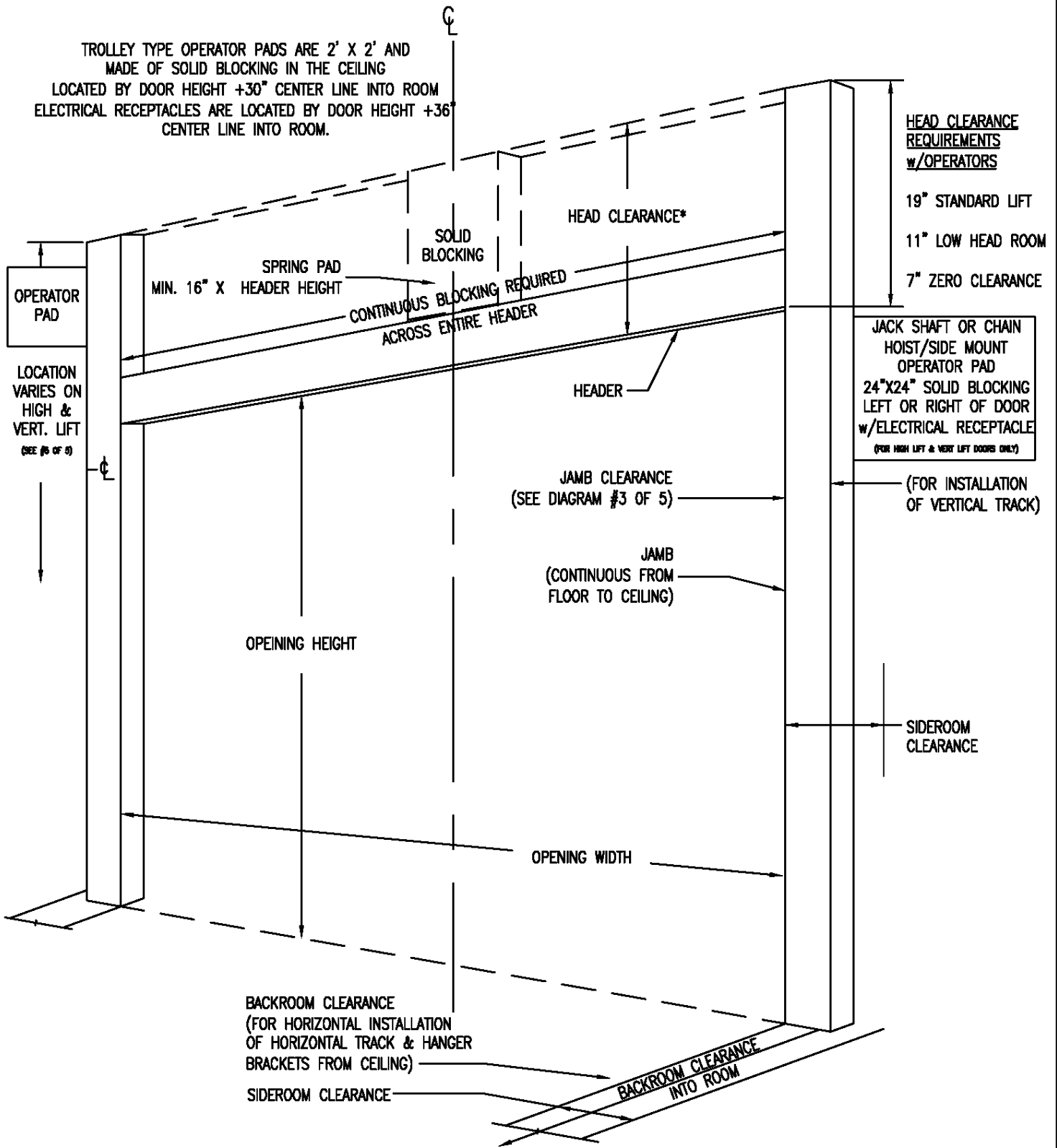

**HEAD CLEARANCE REQUIREMENTS w/OPERATORS**  
 19" STANDARD LIFT  
 11" LOW HEAD ROOM  
 7" ZERO CLEARANCE

JACK SHAFT OR CHAIN  
 HOIST/SIDE MOUNT  
 OPERATOR PAD  
 24"X24" SOLID BLOCKING  
 LEFT OR RIGHT OF DOOR  
 w/ELECTRICAL RECEPTACLE  
 (FOR HIGH LIFT & VERT LIFT DOORS ONLY)

(FOR INSTALLATION OF VERTICAL TRACK)

BACKROOM CLEARANCE INTO ROOM

PREPARATION OF THE OPENING



BRYCE PARKER COMPANY  
 9412 GIDLEY STREET  
 TEMPLE CITY, CA 91780  
 (877) 442-1716

DRAWING  
 2 OF 5

# PREPERATION OF 2" OR 3" TRACK REQUIREMENTS AND SIDE JAMB CLEARANCES - PLAN VIEW

## LAG BOLT INSTALLATION

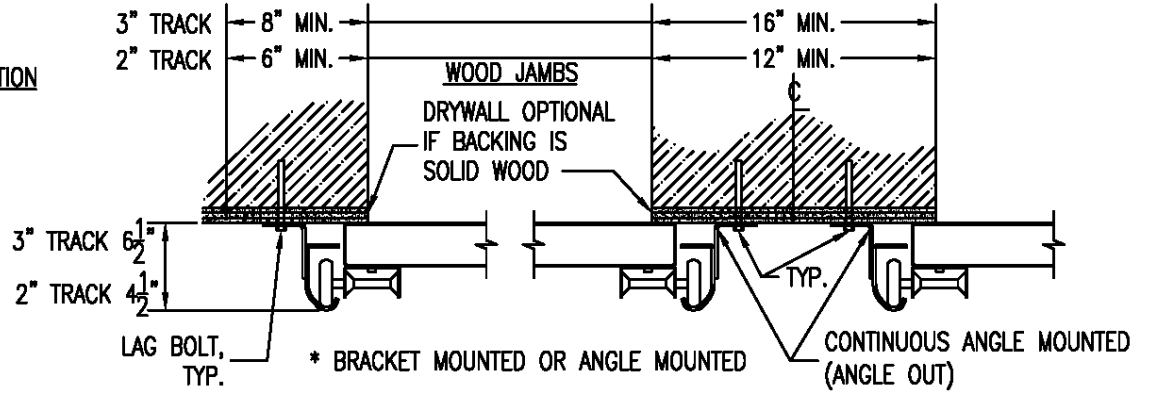

## CONCRETE FASTENER INSTALLATION

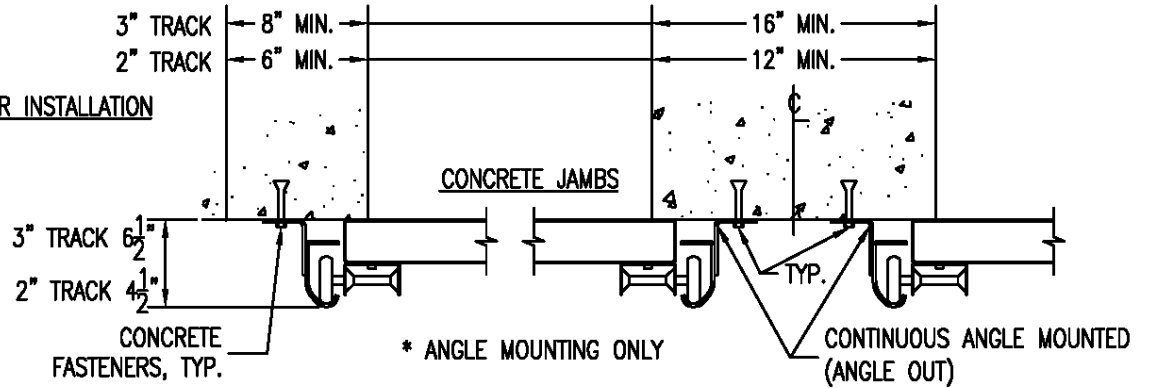

## WELDED INSTALLATION

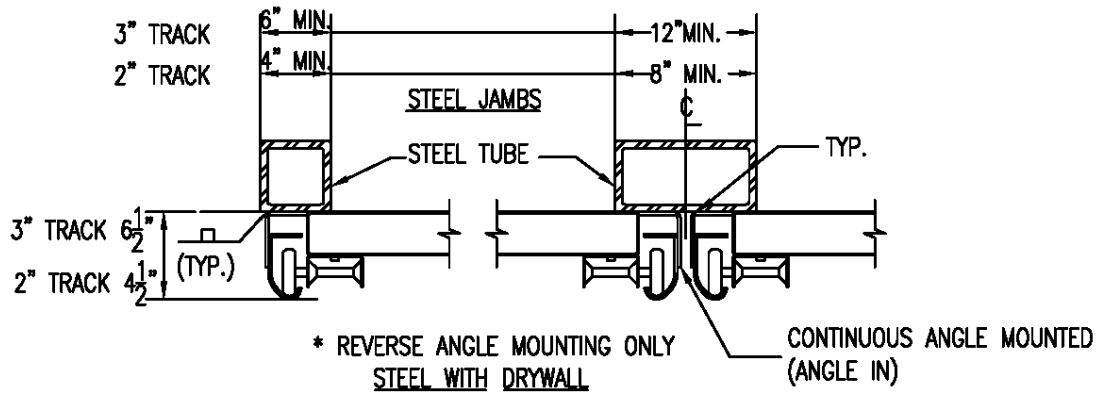

## THREADED SCREW INSTALLATION

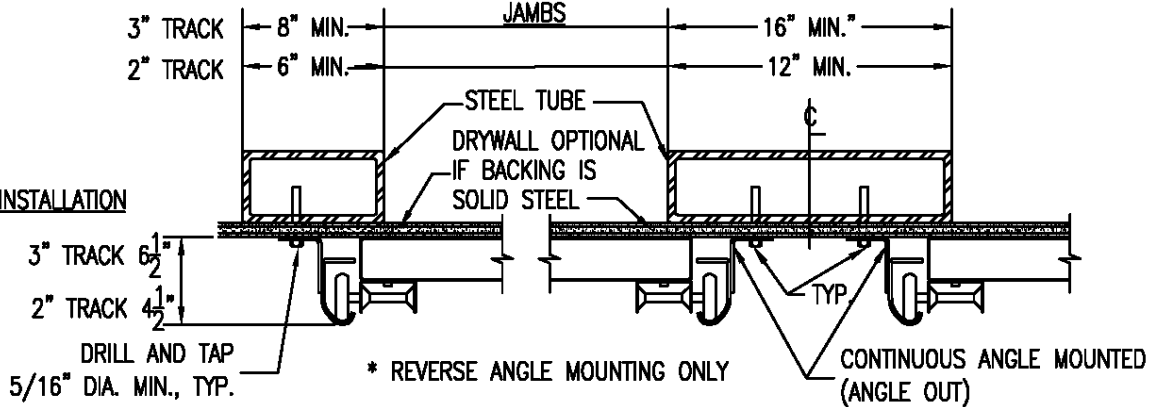

## SIDE TRACK CLEARANCES



BRYCE PARKER COMPANY  
9412 GIDLEY STREET  
TEMPLE CITY, CA 91780  
(877) 442-1716

DRAWING  
3 OF 5

2 SPRINGS - PLAN VIEW

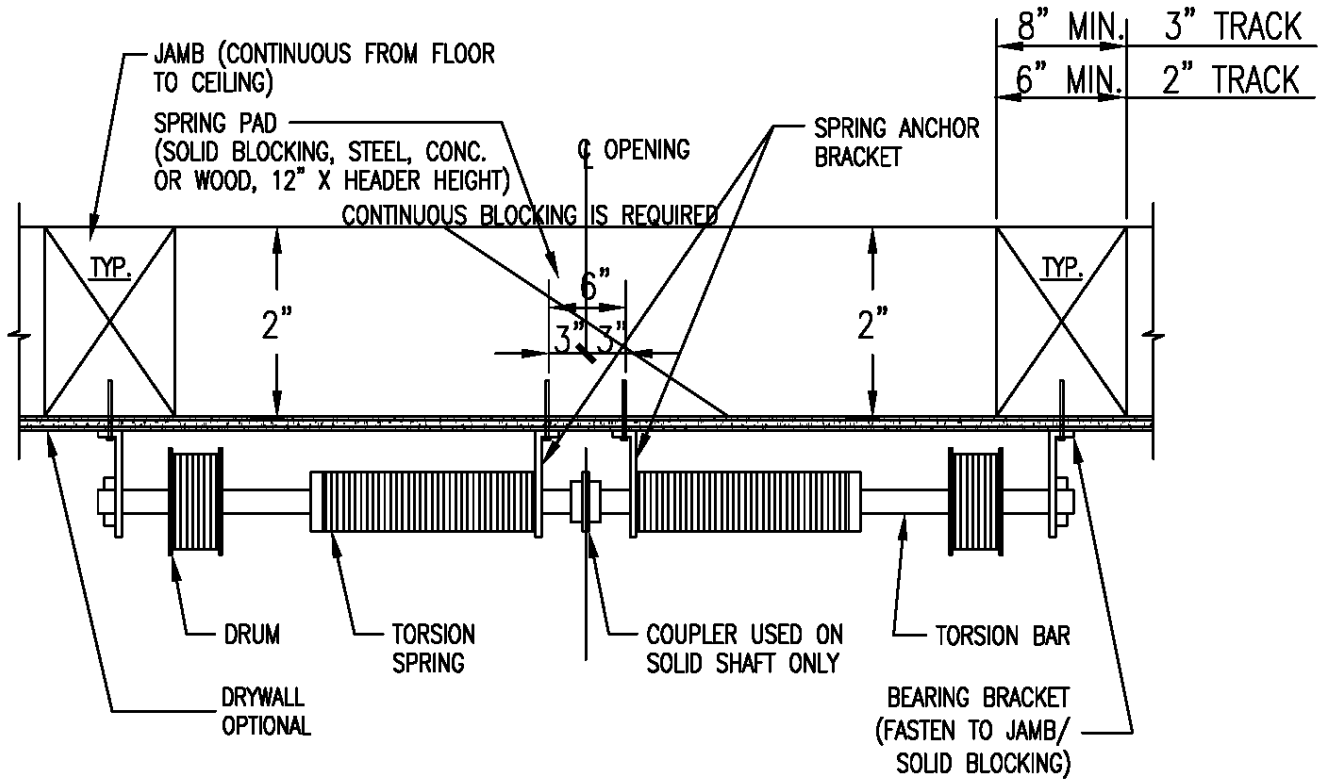

2 SPRINGS - FRONT ELEVATION

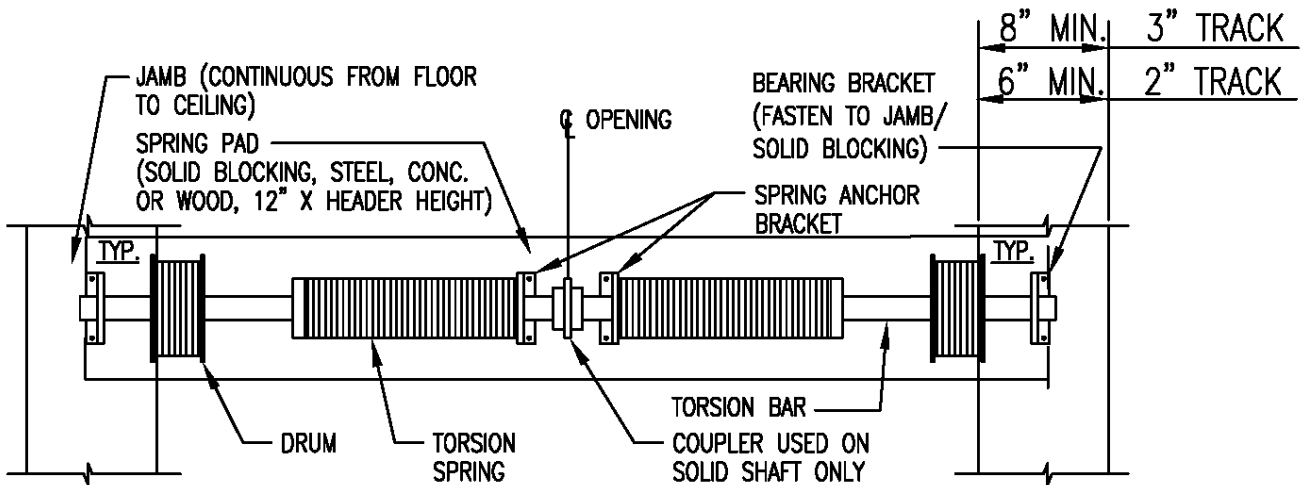

CONTINUOUS BLOCKING IS REQUIRED  
 NOTE: JAMBS ARE CONTINUOUS FROM FLOOR TO CEILING (SEE DIAGRAM #2 OF 5)

SPRING ANCHOR PAD



BRYCE PARKER COMPANY  
 9412 GIDLEY STREET  
 TEMPLE CITY, CA 91780  
 (877) 442-1716

DRAWING  
 4 OF 5

## TRACK SELECTION GUIDE & CLEARANCES

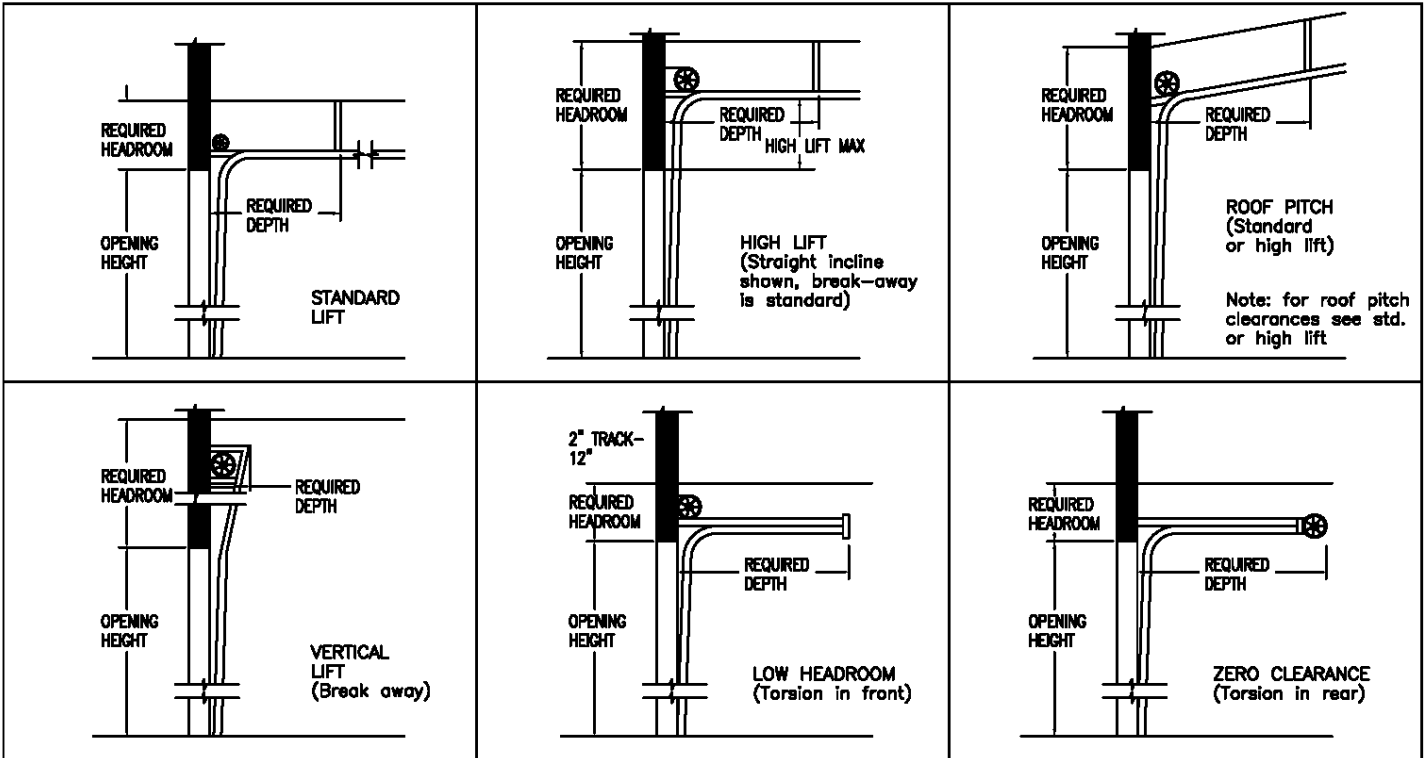

### OPERATING CLEARANCES

	HEADROOM REC.		SIDE ROOM		DEPTH INTO ROOM (PERPENDICULAR TO DOOR)
	2" Track	3" Track	2" Track	3" Track	2" & 3" Track
Standard Lift Manual	16"	21"	6"	8"	Opening Height + 18"
Standard Lift Motor Oper. *	19"	24"	6"	8"	Opening Height + 30"
High lift Manual ***	High Lift + 12"		6"	8"	Opening Height-Lift + 30"
High Lift Motor Oper. **	High Lift + 12"		24"x24" One side of header**		Opening Height-Lift + 30"
Vertical Lift Manual ***	Door Height + 18"		6"	8"	18"
Vertical Lift Motor Oper. **	Door Height + 18"		24"x24" One side of header**		18"
Low Headroom Manual	N/A	N/A	N/A	N/A	Opening Height + 18"
Low Headroom Motor Oper. *	11"	14"	6"		Opening Height + 30"
Zero Clearance Manual	N/A	N/A	N/A	N/A	Opening Height + 18"
Zero Clearance Motor Oper.	7"	10"	6"		Opening Height + 30"

\* Standard Lift, Low Headroom, and Zero Clearance Track are for trolley type operators.

\*\* High Lift and Vertical Lift clearances are for jack shaft or chain hoist/side mounted type operators. See diagram #2 of 5

\*\*\* 4" of additional side room is required (one side) for doors having chain hoists. (Chain hoists are for vertical & high lifts only)

NOTE 1: See diagram #2 of 5 for side mount (jack shaft) operator preparation. The location of the spring pad is determined by the door height (+) the amount of high lift or vertical lift (-) 18" below headroom requirements (center line of operator pad)

### TRACK SELECTION GUIDE & CLEARANCES



BRYCE PARKER COMPANY  
9412 GIDLEY STREET  
TEMPLE CITY, CA 91780  
(877) 442-1716

DRAWING  
5 OF 5

# **bp - GLASS GARAGE DOORS & ENTRY SYSTEMS**

A Product of Bryce Parker Company, Inc.

9412 GIDLEY ST. - TEMPLE CITY, CA 91780

Toll Free: (877) 442-1716 - FAX (626) 579-5320 – WEB: GlassGarageDoors.com

## ARCHITECTURAL SPECIFICATIONS

### **bp - ALUMINUM & GLASS SECTIONAL OVERHEAD DOORS**

**Manufactured for Shipment across the entire USA**

**Factory Direct Installations throughout CA, AZ, NV, and Optional In All Other States**

- MANUFACTURER:** Aluminum & Glass Sectional Overhead Doors: Full Vision Type or Obscured Vision Type  
Manufactured by **bp - Glass Garage Doors** in Temple City, CA - Toll Free (877) 442-1716  
An established manufacturer with 55 years experience specializing in Sectional Glass Doors.
- GENERAL INFO.:** **Models: BP- 350** (4 ft.-12ft. wide x 12 ft. high or 350 lbs max.)  
**BP- 450 HD** (12 ft.-18 ft. wide x 14 ft. high or 700 lbs max.)  
**BP- 550 SHD** (18 ft.-24 ft. wide x 16 ft. high or 1600 lbs max.)
- METAL / FRAMES:** All sections are constructed of **bp** - extruded aluminum alloy. The tensile strength is a minimum of 38 ksi, and approximately double the strength of standard 6063-T5 aluminum alloy.  
All rails are heat treated to maximum hardness as per Aluminum Association Standards.  
**Model BP- 350:** has a minimum wall thickness of .080 inches.  
**Model BP- 450 HD:** has a minimum continuous wall thickness of .105 inches.  
**Model BP- 550 SHD:** has a minimum continuous wall thickness of .188 inches at key structural load points, an imbedded concealed stiffening strut at .135 inches, and Auxiliary concealed stiffening struts at .250 inches for doors 17 ft. - 24 ft. wide.
- STILES AND RAILS:** **Model BP- 350:** Top rails, bottom rails, and end stiles are 3-1/4" wide.  
**Model BP- 450 HD:** Top & Bottom rails are 5-3/8" wide and end stiles are 3-1/4" wide  
**Model BP- 550 SHD:** Top & Bottom rails are 7-3/8" wide and end stiles are 3-1/4" wide  
Horizontal meeting rails have a combined width of 2-3/4".  
Vertical intermediate center mullions are 1-1/2" wide.  
Zinc-plated 5/16" thru-bolts, nuts, and washers are used to rigidly secure all stiles and rails.
- FINISH:** All rails are standard clear anodized at least 4 mill thick for a permanent luster finish.  
Powder coated frame colors must be chosen from the RAL European color standard. (Optional)  
(Kynar paints and custom coatings will be considered & approved on an individual basis only)
- DOOR THICKNESS:** 1-3/4" thick.
- JOINTS:** All joints are mitered to form a tight and smooth fit with the door rails.
- COUNTER BALANCE:** Galvanized torsion springs, head-plates, and center spring supports are mounted on a continuous galvanized torsion bar and calculated to exact weight and travel of each door.  
Cable drums are of die cast aluminum and are paired for the track type specified.  
Lift cables are of high tension galvanized aviation type. (1/8", 3/16", or 1/4" as required by weight)  
Stainless Steel springs, and related hardware can be substituted in lieu of galvanized (Optional)
- TRACK:** 2 inch x 15ga. galvanized continuous angle mounted (15 inch or 20 in. radius x 600lb max.)  
3 inch x 12ga. galvanized continuous angle mounted (15 inch radius x 1200lb max.)  
3 inch x 12ga. Stainless Steel continuous angle mounted (15 inch radius x 1400lb max) (Optional)  
All tracks are tapered to insure a weather-tight fit when in the closed position.  
(See "Track Selection Guide" for headroom requirements on drawing 5 of 5 to specify track type)
- HINGES:** **bp** - Stainless Steel 12ga. universal and offset type, are graduated at each section to insure weather tight fit. **bp** – Stainless Steel hinges do not require lubrication. (Standard)





# bp - GLASS GARAGE DOORS & ENTRY SYSTEMS

A Product of Bryce Parker Company, Inc.

9412 GIDLEY ST. - TEMPLE CITY, CA 91780

Toll Free: (877) 442-1716 - FAX (626) 579-5320 – WEB: GlassGarageDoors.com

## ROLLERS:

2 inch **bp** - Stainless Steel, polymer coated tire, sealed, 500 lb, precision bearing, roller (Standard)  
3 inch **bp** - Stainless Steel, polymer coated tire, sealed, 700 lb, precision bearing, roller (Optional)  
**bp** – Stainless Steel sealed rollers do not require lubrication. (Standard)

## WEATHER-STRIP:

A Santoprene gasket is applied at the factory the full length of the bottom section and at each end of the top rail where contact is made with the bumper spring.

**bp** - Architectural perimeter weather-stripping is made of a three-part extruded aluminum and Santoprene system, which conceals the fasteners with a snap cover. The **bp** – Architectural Perimeter Weather Stripping can be exterior or interior mounted for a clean Architectural finish.

## OPERATORS:

Manual chain-hoists are compatible with standard, roof pitch, high-lift, and full vertical lift tracks. Electric operation must be specified with the following: Push button station, BEST Core Key Switch, and/or remote control operation. Auto reversing safety sensors are required for residential use and optional for most commercial applications. Operator specifications are per **bp – Glass Garage Doors** factory recommendations; based on weight, height, track type, and as required per code. (Note: Low headroom & Zero-clearance track must be electronically operated for safety)

## GLAZING:

Glass, aluminum, or specialty panels ranging from: 1/16” – 1/2” / 1.5mm – 12.7mm thickness are encased in vinyl moldings, held in place by aluminum snap-in beads, and are designed to be easily removed and replaced in case of glass or panel breakage.

## GLASS SPECIFICATIONS:

Glass type must be specified with the following: Transparent or obscured frosted, tempered, laminated safety glass, or insulated glass (IG), and clear or color tinted hues.

**Tempered Glass** meets the quality and strength requirements of ASTM C 1036 and ASTM 1048 for condition A, Quality q3, and Kind FT (Full Tempered). Tempered glass also meets the safety criteria of CPSC 16 CFR 1201 Categories 1 & 2, ANSI Z97.1, and qualifies as the glazing material for use in hazardous locations.

**Laminated Safety Glass** (0.030 PVB or thicker interlayer with two lites of glass) also meets the safety criteria CPSC 16 CFR 1201 Categories 1 & 2, ANSI Z97.1, and ASTM C 1172 Standard Specifications for Laminated Architectural Flat Glass. 1/4" laminated glass has an STC of 35.

**Insulated Glass Units** - IG Units supplied are listed as having CBA Certified Products through IGCC (Insulating Glass Certification Council), as tested in accordance with ASTM E2190 Standards. Insulating glass will consist of two lites of glass separated by a dehydrated airspace and dual-sealed with a polyisobutylene primary sealant, and a silicone secondary sealant.

## OPTIONAL:

1/8” - 1/4” custom glass panels, 1/2” IG Units, 1/2” Insulated Aluminum panels, 1/16” - 1/4” aluminum or specialty panels, ventilation louvers, interior-mounted security bars, Tapered bottom sections (for use when floor is out of square or sloping), custom panel locations, widths, and varying sections heights within the same door can also be accommodated to meet custom designs.

**Florida Building Code Compliant options include:** Miami-Dade NOA 10-0802.02, FL13380. (+65.0 / -65.0 PSF Small and Large Missile Impact Rated)

Products that are required to comply with Miami-Dade County Building Code Compliance Office and the Florida Building Code are approved by Architectural Testing, Inc. for Quality Assurance.

### **Certified Products Options include:**

NFRC400 / ASTM E283 Air leakage resistance

NFRC100 Thermal Ratings for U-factor, SHGC, and VT (IG units only)

NFRC Certified Products participate in a Quality Control & Testing Certification Program by the American Architectural Manufacturers Association (AAMA).

**bp** – Glass Garage Doors may help a project achieve third-party certifications such as USGBC LEED.

VIEW GLASS PANEL OPTIONS & ADDITIONAL INFORMATION ON THE WEB: [www.GlassGarageDoors.com](http://www.GlassGarageDoors.com)



# bp Glass Garage Doors

## "The Architect's Choice"

### bp Advantages (Our Door)



### Competitors' Disadvantage (Competitor Door)



- ➡ **BP- Aluminum Alloy:** High tensile strength at 38 ksi and double the rigidity of standard alloy.
- ➡ **Standard (6063) Aluminum Alloy:** Much weaker and 1/2 the tensile strength of BP - Aluminum Alloy.
- ➡ **Narrow Intermediate Mullions:** Cleaner architectural lines, showing more glass and less structure.
- ➡ **Wide Intermediate Mullions:** Shows less glass, more frame, and is visually less appealing (See above, marked by arrows).
- ➡ **Heavier Wall Thickness:** Allows for more weight and wider glass panels, without deflection. (Ex. Our door has 250 lbs of aluminum vs. a competitor's 100 lbs.)
- ➡ **Thinner Wall Thickness:** Causes vertical and horizontal deflection, which requires stiffening struts that can be seen through the glass. (See above, as marked by red arrows)
- ➡ **Factory Direct Manufacturing Speed:** By strictly focusing on Glass Garage Doors and Entry Doors, our manufacturing time is the best in the industry.
- ➡ **Not Factory Direct:** Orders are placed through a distributor, and can take 6-10 weeks.
- ➡ **Factory Direct Installation (CA, AZ, NV, FL & Optional in all other states):** A factory specified installation produces a smoother and longer lasting garage door.
- ➡ **Not Factory Installation:** An installer other than the factory may not have the expertise or take the time needed to meet a factory specified installation.
- ➡ **Customization:** Our customers can request specific panel sizes, quantities, height of each section, tapered bottom / top sections, and reveal of frame around the door.
- ➡ **Limited Customization:** Our competitors are not set up to accommodate customers' special requests.
- ➡ **Complementing Entry Doors:** We can manufacture Entry Doors and Side Gates with single or multiple glass panels to match your Glass Garage Door. Custom Lock hardware can also be accommodated.
- ➡ **No Complementing Entry Doors:** Our competitors are not set up to accommodate customers' special requests.

- ➡ **Stainless Steel 11-gauge Hinges:** Laser cut, heavy duty hinges for an extra clean Architectural finish. Note: Stainless Hinges do not require lubrication.
- ➡ **Standard Mild Steel Hinges:** Thinner 14 to 18 gauge galvanized hinges are weaker, may break under typical glass weights, and require constant lubrication.
- ➡ **Stainless Steel Rollers:** Heavy Duty, sealed, water resistant rollers of 500lb load capacity each, with no lubrication required.
- ➡ **Standard Metal or Nylon Rollers:** 50lb. load capacity each, non sealed, and require constant lubrication.
- ➡ **Zinc Plated or Stainless Steel Springs:** Rust resistant and do not require lubrication.
- ➡ **Standard Springs:** Raw oil tempered springs rust and require constant lubrication.
- ➡ **Concealed Stiffening Struts:** Stronger, lighter, and are hidden as part of the door rail, which won't be seen from the outside.
- ➡ **Standard Metal Struts:** Weak, heavy, surface mounted, and can be seen through glass. (See above, marked by arrows).
- ➡ **Custom Glass and Frame Colors:** Over 200 types of custom glass, powder coated colors, and panels to choose from.
- ➡ **Limited Glass and Color Options:** A few standard glazing types and color options.
- ➡ **Architectural Weather Stripping:** Made from 3 part extruded aluminum, commercial Santoprene, and installed with concealed fasteners.
- ➡ **Typical Residential Weather Stripping:** Made entirely of poor quality vinyl with exposed nails which rust.
- ➡ **Custom Tapered Sections:** Top and/or bottom sections/panels for out of square driveways and openings. (See picture gallery)
- ➡ **Standard Rectangular Sections:** May otherwise leave large gaps at the floor and header.
- ➡ **Commercial Duty Hardware:** High capacity, long lasting, with minimum lubrication or service required.
- ➡ **Standard Residential Hardware:** Low capacity, which wears out quickly; requiring constant lubrication, and costly service calls.
- ➡ **Extremely Quiet Operation:** Due to the use of premium components, noise-causing friction is dramatically reduced.
- ➡ **Typical Noisy Operation:** Attributed to cheap components, and out of square track; which cause friction and costly repairs.
- ➡ **What Makes bp the best:** In addition to the reasons above, proprietary fabrication methods and classified materials have been incorporated to produce our highly regarded glass doors.
- ➡ **Why Others Can't Compare:** Manufacturers that mass-produce a wide variety of other types of doors are catering to a less discriminating market. In most cases, quality is compromised for quantity.

**You get what you pay for!** Quality engineered and tested designs for over 55 years in business!

---

**The bp Experience :**

Purchasing a sectional garage door from us is just a lot simpler. We manufacture, install, and warranty our own product.



# Sample Colors

## *Special Effect Powder Coating Options*



9017 ACACIA DS403



9026 CHERRY DS403



9026 CHERRY DS402



9052 OAK ASSI DS409



9052 OAK ASSI DS414



9052 OAK ASSI DS403



9053 DOUGLAS DS402



9103 KN PINE DS402

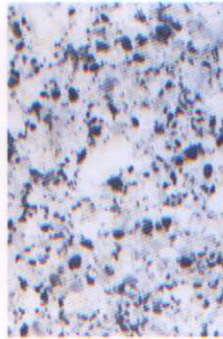

9105 WHITE GRANITE DS404



9128 DK WALNUT DS403



9173 BURLWOOD DS403



9052 OAK ASSI DS402

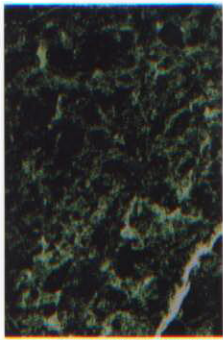

9065 GRN MARBLE DS411/410



9017 ACACIA DS402



9017 ACACIA DS406



9061 CHERRY FLAME DS403



9173 BURLWOOD DS411/410



9057 MARBLE DS404

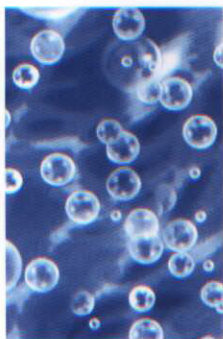

51932 BUBBLE DS404



9053 DOUGLAS DS403

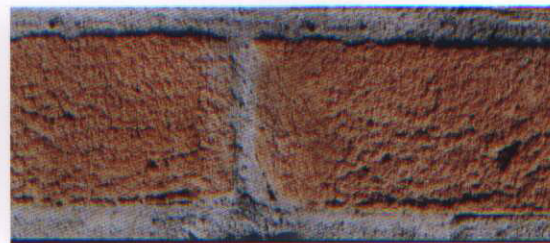

BRICKS

### **About Color:**

The color illustrations shown are as accurate as photography and printing processes allow. Final selection of colors should be made from physical samples.