

TecCrete Access Flooring

Application Guide

Table of Contents

Introduction.....	6
Product Overview	
Statement of Line: Panels	7
Statement of Line: Heads and Bases	8
Statement of Line: Accessories	9
Cornerlock: Bare Panels	11
Rigid Grid: Covered Panels	12
Cornerlock and Non-Cornerlock Product Features	13
TecCrete Cornerlock and Non-Cornerlock Panel Performance Ratings	14
Airflow Panels	15
Airflow Panel Product Features	16
TecCrete Low-Profile Pedestal Assembly.....	17
Standard Cornerlock Understructure	19
Pedestal Bases	20
Rigid Grid Understructure	21
Product Application	
Understructure Applications	22
Cornerlock with Expansion Joint and Expansion Joint Detail	24
Wall Surface Partition and Doorway Applications	26
Angled Wall Applications	31
Specialty Floor Finish Applications: Finish Transitions	32
Floor Area Transitions	34
Bridging Obstructions on Subfloors	37
Ramp Details	38
Mounting Equipment to TecCrete Access Floors	39
Fire and Safety Applications	42
Bathroom Applications	44
Electrical Applications	45
Controlling Air Leakage	46
Proper Air Sealing Before and During Access Floor Installation	48
Plenum Applications	50
Plenum and Air Highway Applications	51
Electrical Overview	
Our Philosophy on Electrical	58
System Overview	59
Statement of Line: Power Base AI	60
Typical Power Base AI Application	62
Voice and Data Overview	
Statement of Line: Pre-Terminated Zone.....	66
LEED®-NC 3	
Introduction.....	68
Energy and Atmosphere	69
Materials and Resources	70
Indoor Environmental Quality.....	73
TecCrete System Performance Ratings	75
TecCrete Access Flooring: Office — Three Part Guide Specification.....	80
TecCrete Access Flooring: Computer Rooms — Three Part Guide Specification	90

TecCrete Product Overview

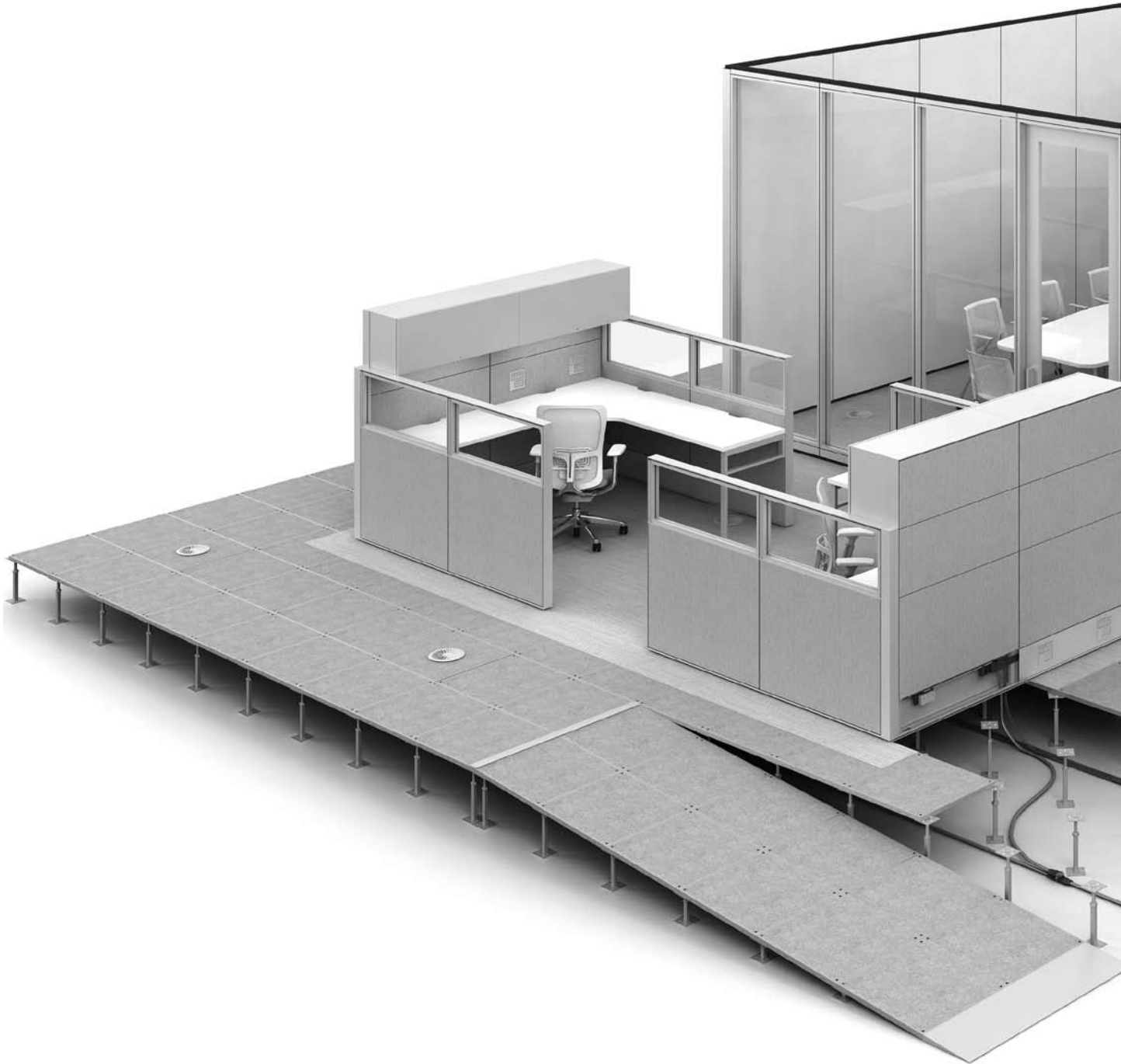



Introduction

Featuring a proprietary concrete-and-steel composite structure and an exposed concrete surface that's beautiful enough to leave bare, Haworth's new TecCrete® builds on a 25-year legacy as the access floor that doesn't feel like one or look like one. It's the strongest and most durable access flooring system in its class. And it's the greenest, manufactured in a Zero Landfill Plant with 58% recycled content. In addition, tight panel gap tolerances and a flat underside make TecCrete ideal for underfloor air distribution. Available bare or with a range of factory-applied finishes, TecCrete is the solid, quiet choice for any environment, from offices to data centers.

Key Features and Benefits

- Designed for office and computer room: TecCrete contains a full range of access floor options.
- Solid underfoot: Flexes 50% less than a conventional raised floor when walked on.
- Durable, weldless construction: Unique steel-and-concrete composite structure eliminates welds that break invisibly during use.
- Stands up to heavy rolling loads: Limits the potential for damage from rolling loads, especially those that occur during construction.
- Solid, single-thickness structure: TecCrete 1250/1500, at 1½" (29mm) thick, and TecCrete 2000/2500, at 1½" (38mm) thick, both have solid concrete and steel construction from end to end.
- "Library Quiet": TecCrete's thickness and density more effectively attenuate sound.
- TecCrete features 58.4% recycled content.
- Flat underside: Allows for easier and more economical installations, sealing of underfloor plenum dividers and tight panel gap tolerances.
- Made from real concrete: Not cementitious slurry like conventional access flooring.
- Beautiful enough to leave bare: The exposed concrete surface offers an aesthetic option not available with other flooring systems.
- Works as a construction platform: Handles the heavier rolling and impact loads that occur during construction and move-in without permanently denting and dishing.
- Rock-solid reliability: No reported failures after 25 years and tens of millions of square feet installed.
- Made in America.

Standard Panel Options

- Strength ratings: Concentrated load of 1,250/1,500 (on stringers) lbs. and 2,000/2,500 (on stringers) lbs.
- Cornerlock and non-cornerlock
- Integral air seal
- Standard grade, finished grade or covered
- Factory supplied cutouts for diffusers, grommets and electrical boxes

Panel Surface Options

- Bare for field applied staining and sealing (finished grade)
- Bare for use under carpeting (standard grade)
- Static dissipative high-pressure laminate with TecTrim
- Static dissipative vinyl with optional vinyl trim
- Conductive vinyl with optional vinyl trim
- Other surfaces available by special order

Companion Products and Systems

- Haworth Power Base AI
- Haworth Pre-Terminated Zone Voice and Data
- Haworth furniture and wall systems

Typical Configuration

- Bare TecCrete 1250/1500 lb. panel corner-locked to pedestals
- Bare TecCrete 1250/1500 lb. or 2000/2500 lb. panel gravity held in a rigid-grid understructure
- Covered TecCrete 1250/1500 lb. or 2000/2500 lb. panel corner-locked with gravity-held rigid-grid understructure
- Covered TecCrete 1250/1500 lb. or 2000/2500 lb. panel non-corner-locked gravity-held rigid-grid understructure

Statement of Line: Panels

Panels

- Panels are available bare, with laminate covering, or vinyl covering.

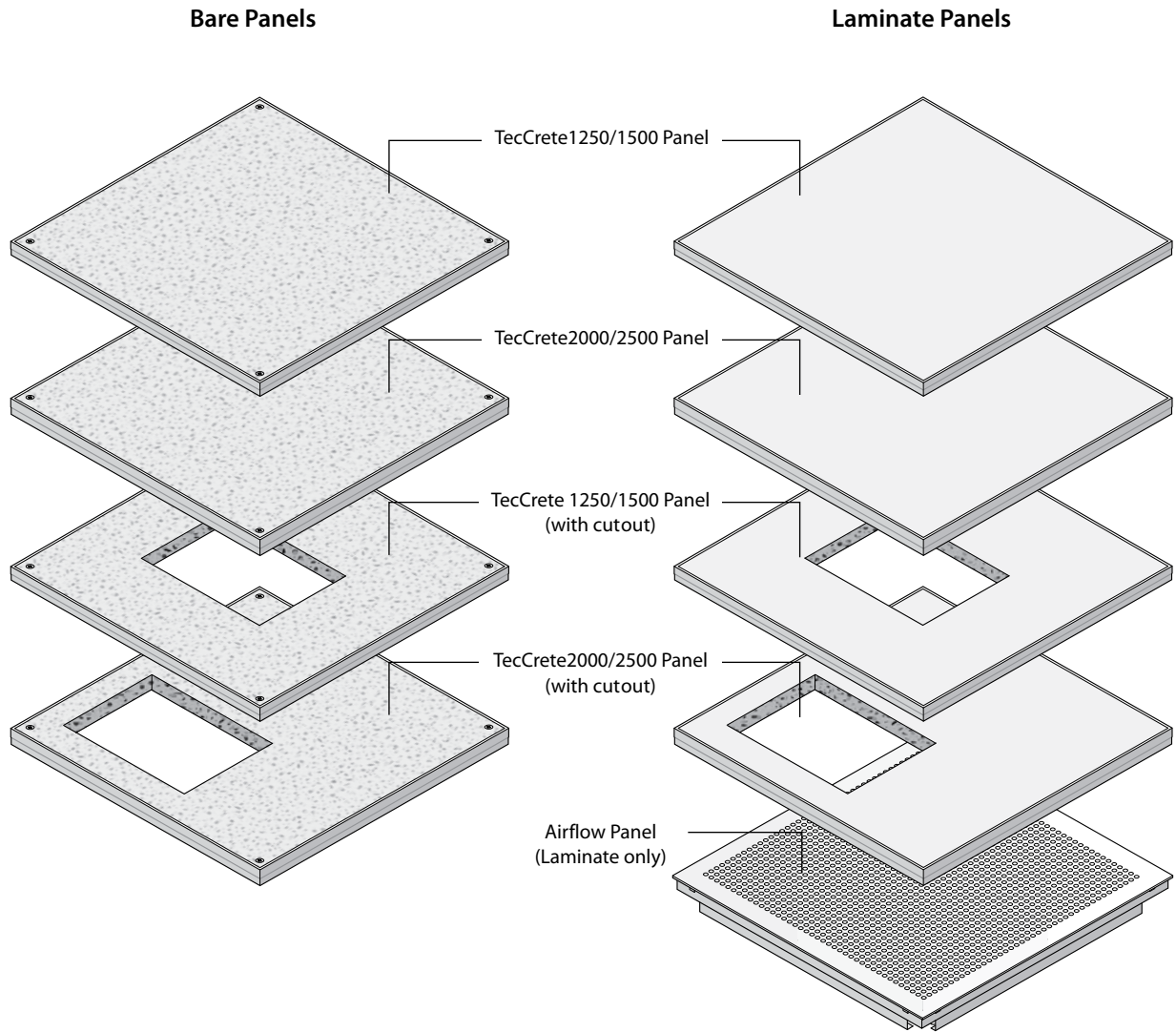

Note See price list for available cutout options.

Statement of Line: Heads and Bases

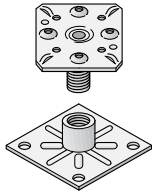

TecCrete Understructure,
Low Profile 3" (76mm) FFH

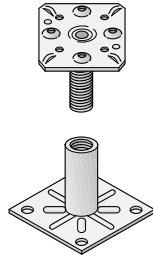
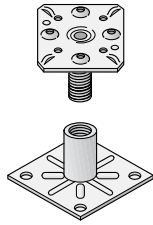

TecCrete Understructure,
Low Profile 4" (102mm), and 5" (127mm) FFH

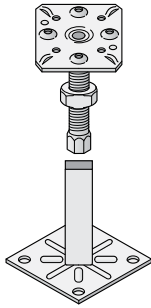

TecCrete1250 Understructure,
Standard Profile 6" (152mm) Minimum
to 30" (762mm) Maximum FFH

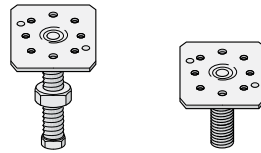

All TecCrete bases are available in
Cornerlock Field Heads or Perimeter Heads
shown above in standard
and low profile versions.

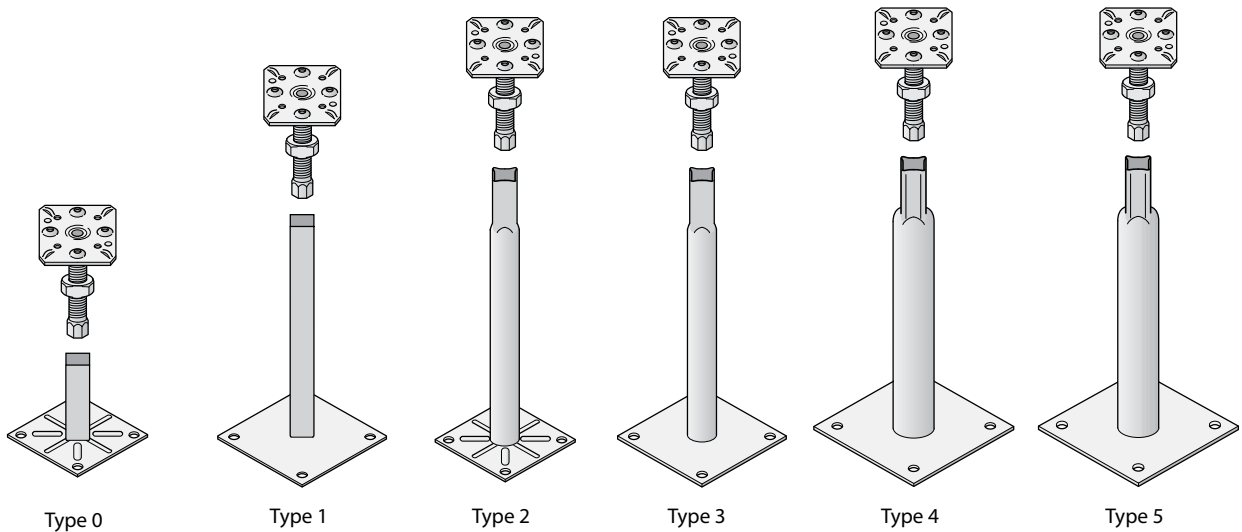

Type 0

Type 1

Type 2

Type 3

Type 4

Type 5

TecCrete1250 Seismic Understructure

Note For additional seismic base options, please see page 20.

Statement of Line: Accessories

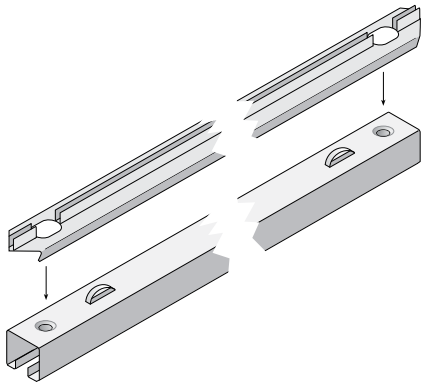

Steel Stringer with Gasket: 2' and 4'

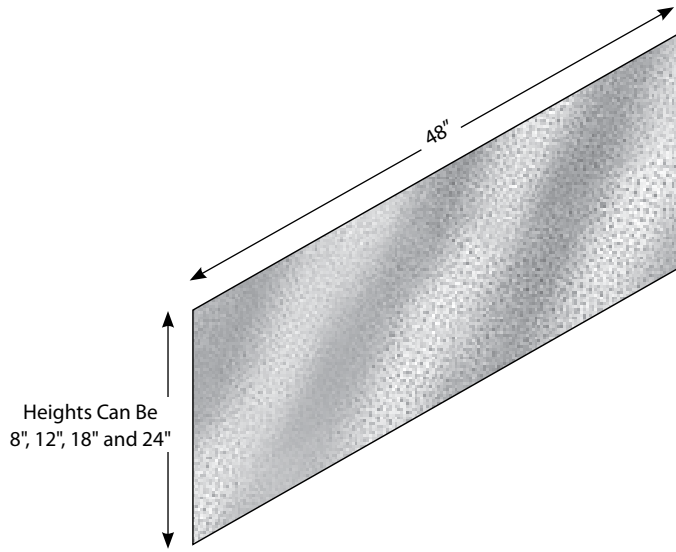

Steel Fascia Plates

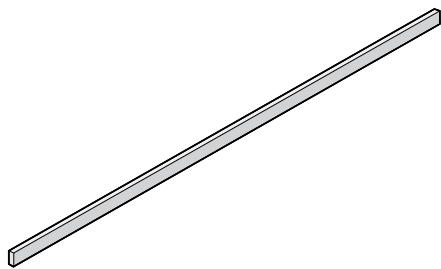

Air Seal

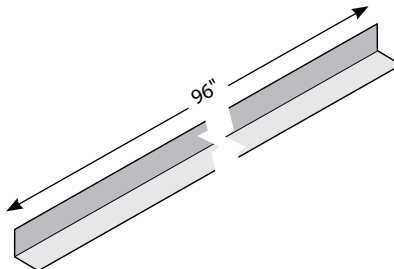

Steel Fascia Bottom Angle

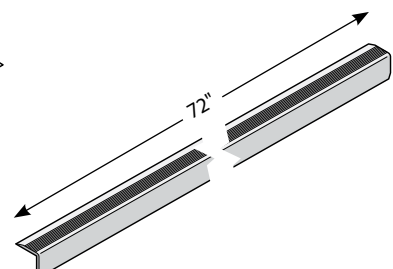

Aluminum Fascia Top Angle

Note: Panel can be ordered with optional integral air seal.

TecCrete Panel Ramp and Components

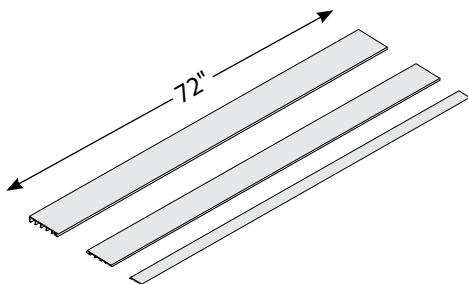
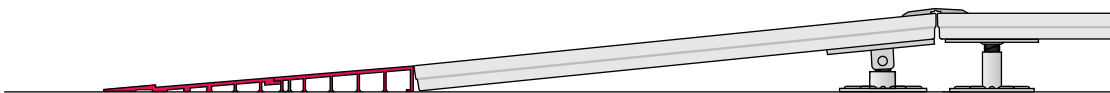

Ramp Shoe Components

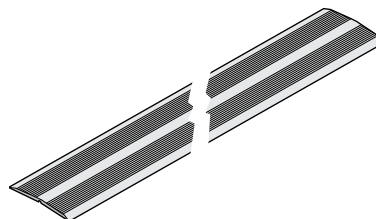

Ramp Threshold

Statement of Line: Accessories



Standard or High-Strength Adhesive

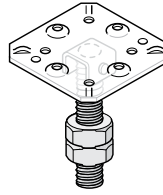

Swivel-Head Pedestal

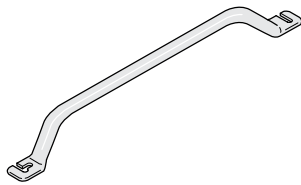
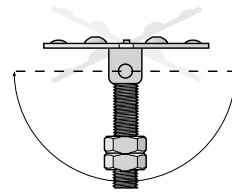

Lifting Bar



Small Single-Cup Laminate Panel Lifter

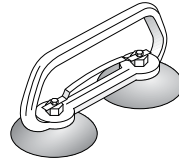

Double-Cup Laminate Panel Lifter

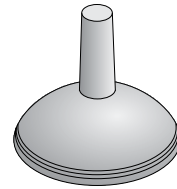

Large Single-Cup Laminate Panel Lifter



Grommet: 1 7/8" and 3"

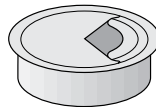
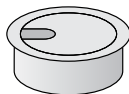

Grommet: 4" and 5"

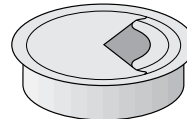

Grounding Screw

Cornerlock: Bare Panels

Self-Positioning
Corner Locks

Light-Weight,
High-Strength Concrete

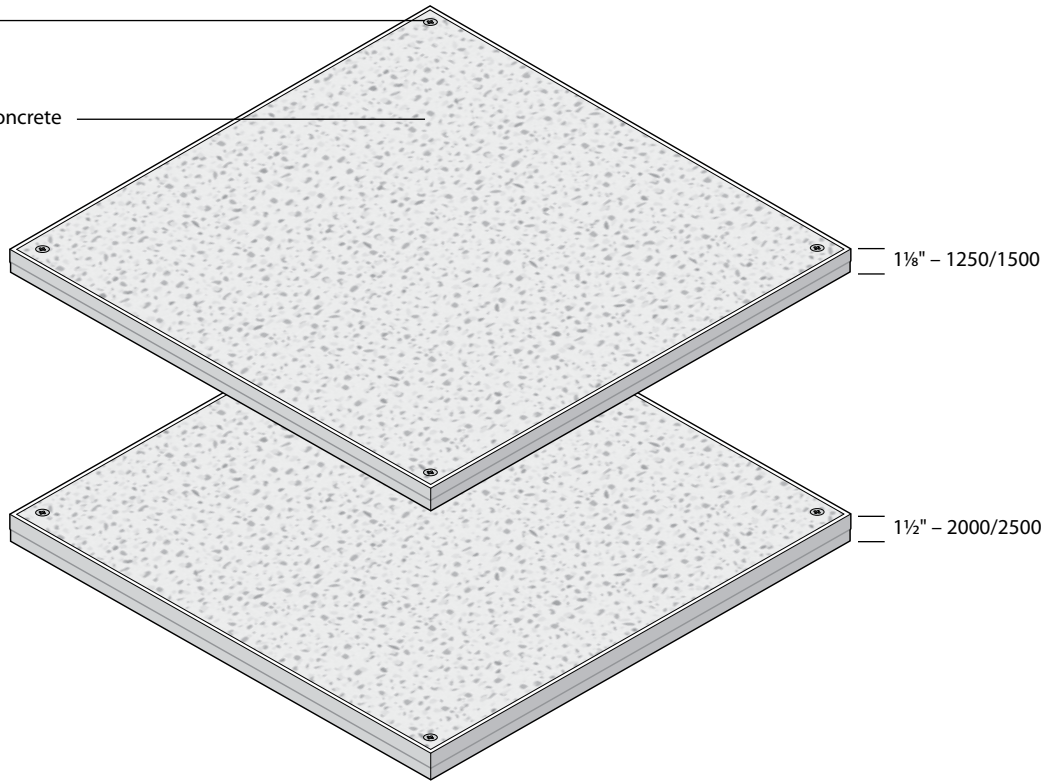

Full Panel

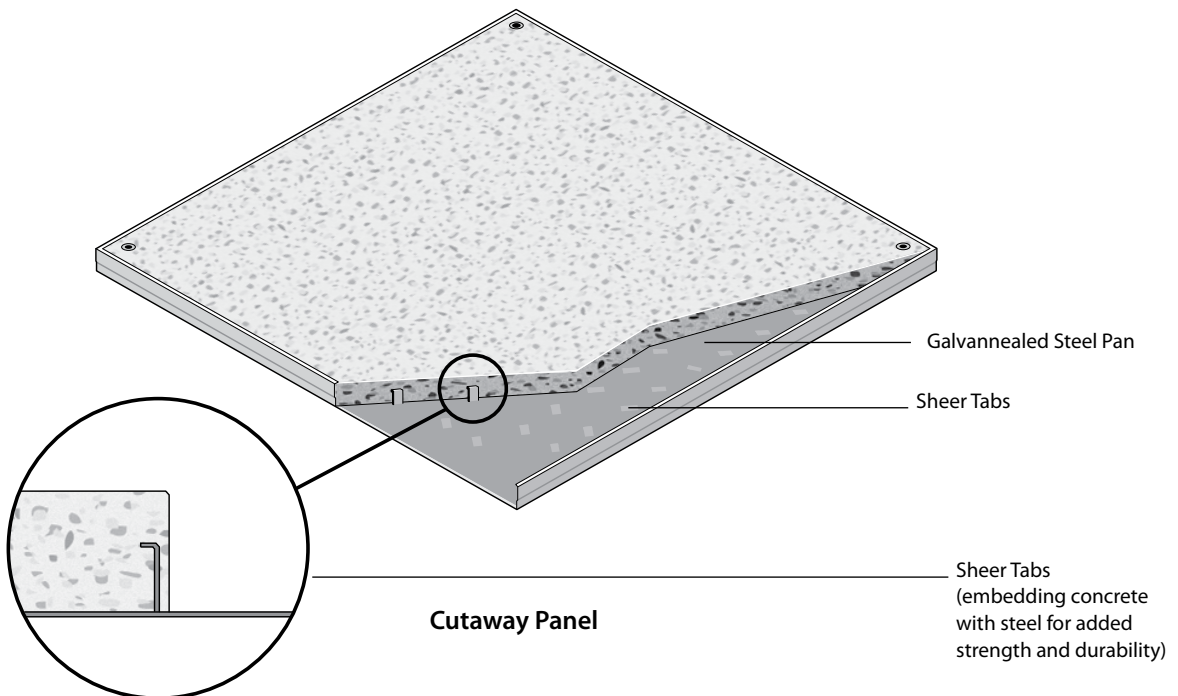

Rigid Grid: Covered Panels

Laminate with TecTrim

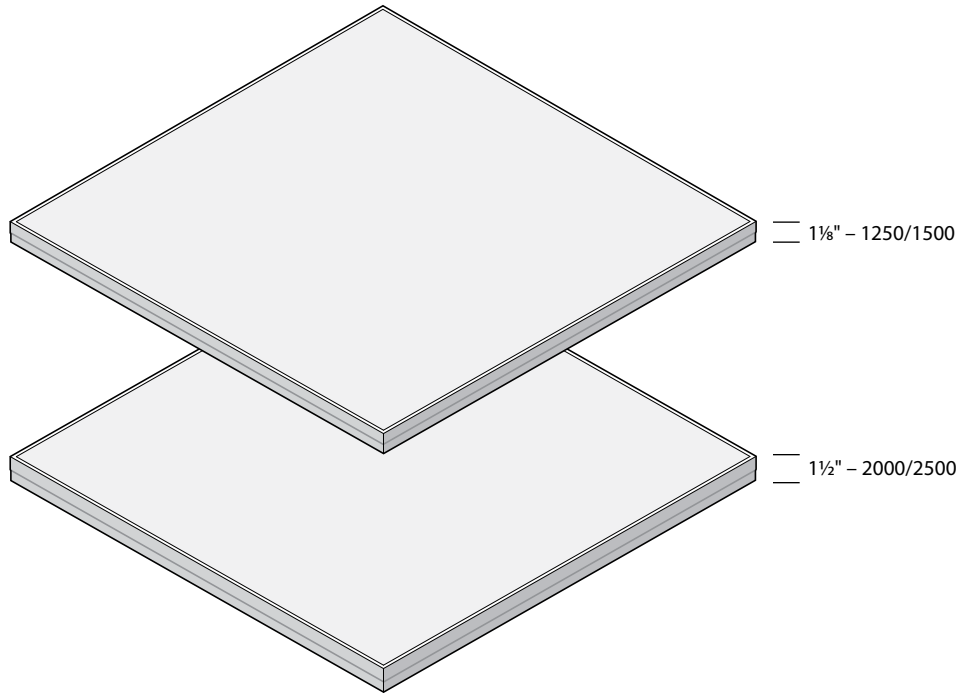

Full Panel

Cornerlock and Non-Cornerlock Product Features

General Information

Construction:	<ul style="list-style-type: none"> • Lightweight high-strength concrete in a galvanized steel pan. Non-combustible.
Panel Size (nominal):	<ul style="list-style-type: none"> • 24" x 24" (610mm x 610mm)
Panel Thickness:	<ul style="list-style-type: none"> • 1250/1500 – 1½" (29mm) high bare finish • 2000/2500 – 1½" (38mm) high bare finish
Panel Weight:	<ul style="list-style-type: none"> • 1250/1500 – 10.5 lbs./ft² (51.27 kgs/m²) bare finish • 2000/2500 – 13.8 lbs./ft² (67.38 kgs/m²) bare finish
System Weight:	<ul style="list-style-type: none"> • 1250/1500 – 11.2 lbs./ft² (54.68 kgs/m²) bare with cornerlock • 1250/1500 – 11.9 lbs./ft² (58.1 kgs/m²) laminate, without cornerlock • 2000/2500 – 14.2 lbs./ft² (69.33 kgs/m²) laminate, without cornerlock
Finished Floor Height:	<ul style="list-style-type: none"> • 3" to 68" (76mm x 1727mm) – Other heights available
Panel Finish:	<ul style="list-style-type: none"> • Bare for field applied staining and sealing (finished grade) • Bare for use under carpeting (standard grade) • Static dissipative high-pressure laminate with TecTrim • Static dissipative vinyl with optional vinyl trim • Conductive vinyl with optional vinyl trim • Other surfaces available by special order
Fire Resistance:	<ul style="list-style-type: none"> • Non-combustible

Panel Options

- Factory supplied water jet cutouts for diffusers, grommets and electrical boxes.
- Integral air seal.
- Factory-applied finishes.

Understructure Options

- Cornerlock pedestal, field, and perimeter understructure is available for low 3" (76mm), 4" (102mm), and 5" (127mm), and standard, 3" to 68" (76mm to 1727mm) finished floor heights.
- Seismic options are also available.
- For non-standard pedestal options, please contact your Haworth representative.
- Stringers are rated at 450 lbs. and available in 24" (610mm) and 48" (1219mm) lengths.
- TecCrete's flat underside allows placement of pedestals anywhere under the panel, making support of partial panels at walls and columns easier and more secure.

Electrical Grounding

- A grounding screw can be used for stringered applications where the panel-to-pedestal resistance is required to be less than 10 ohms.

Underfloor Air Applications

- Integral air seal strip can be specified for plenum applications not utilizing carpet tile or stringers to minimize cost and optimize underfloor air system performance.
- TecSeal™ air seal strip provides a plenum seal when TecCrete is used with a bare finish in an underfloor air application. TecSeal is a trademark of Haworth, Inc.

Companion Products and Systems

- Haworth Power Base AI Modular Power.
- Haworth Pre-Terminated Zone Voice and Data.
- Haworth furniture and wall systems.

TecCrete Cornerlock and Non-Cornerlock Panel Performance Ratings

Access Floor Performance Ratings	Dynamic Load Rating			Static Load Rating		
	ROLLING 10 PASSES	ROLLING 10,000 PASSES	IMPACT 36" DROP	CONCENTRATED PSI	UNIFORM PSF	ALLOWABLE/ DESIGN LOAD
TecCrete 1250/1500 1 1/8" without Stringers	1,200 lbs.<0.040 (554 kg)	800 lbs.<0.040 (363 kg)	150 lbs. (68 kg)	1,250 lbs.<0.10 (568 kg)	600 PSF (272 kg)	2,720 lb. 12099 N
TecCrete 1250/1500 1 1/8" with Stringers	1,500 lbs.<0.040 (682 kg)	1250 lbs.<0.040 (568 kg)	150 lbs. (68 kg)	1,500 lbs.<0.10 (682 kg)	700 PSF (318 kg)	3,800 lb. 16903 N
TecCrete 2000/2500 1 1/2" with Stringer	2,000 lbs.<0.040 (907 kg)	1,750 lbs.<0.040 (794 kg)	150 lbs. (68 kg)	2,500 lbs.<0.10 (1136 kg)	1100 PSF. (500 kg)	3,800 lb. 16903 N

Note For detailed information on testing and system performance ratings, please see page 75.

Airflow Panels

The airflow panel is used to cool high-density computer equipment typically found in a server room, data center, or telecommunications center. The airflow panel is constructed from a welded grid frame and top sheet assembly perforated to create a 23.6% open area. At 0.1 inches water gauge pressure, it produces 14% more CFM than similar airflow panels.

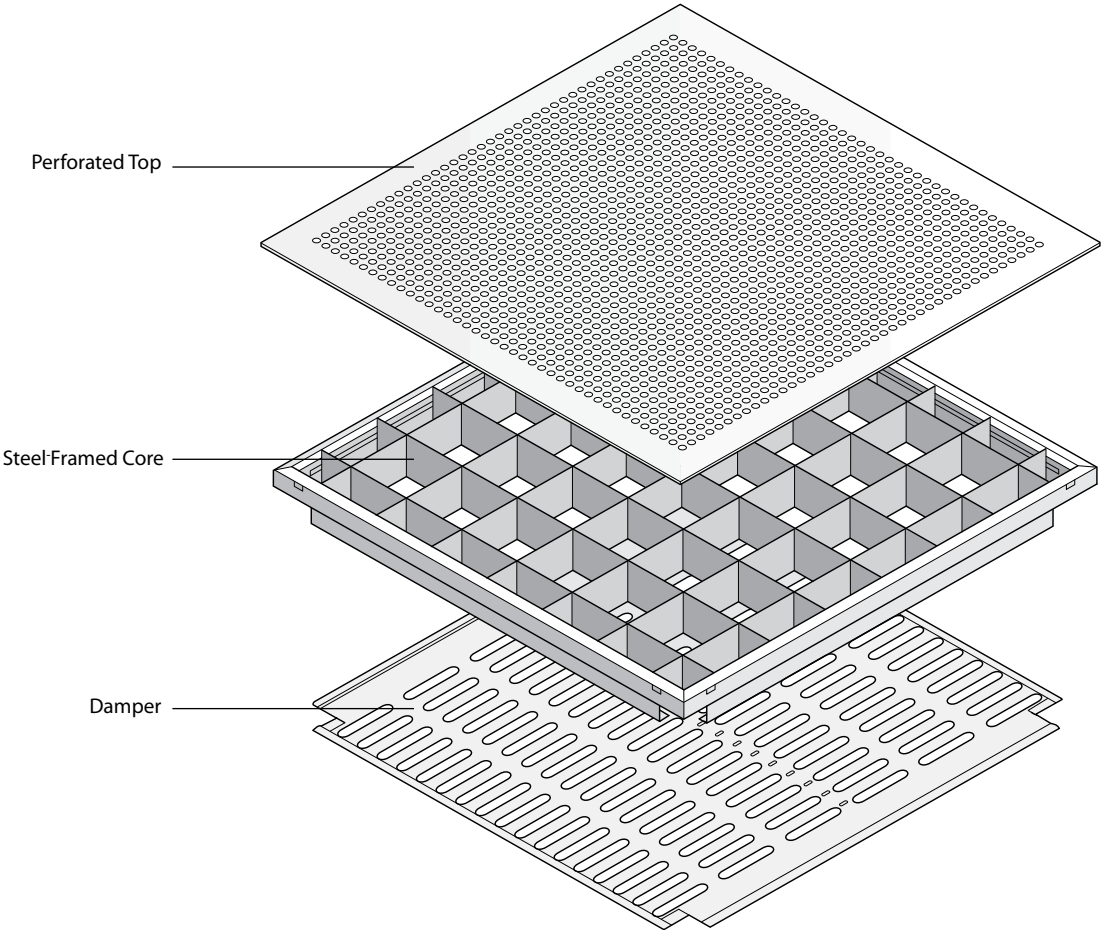

Airflow Panel Product Features

General Information

Construction:	• Classic welded steel frame and top sheet
Panel Size (nominal):	• 24 x 24 (610mm x 610mm)
Panel Thickness:	• 1 $\frac{1}{8}$ " (36.5mm) with high-pressure laminate (HPL) or vinyl
Panel Weight*:	• 30.0 lbs. (4.54 kgs) with HPL and damper
System Weight:	• 8.0 lbs./ft ² (4.54 kgs/m ²) with HPL and damper
Finished Floor Height:	• 6" to 68" (152mm x 1727mm) – Other heights available
Panel Finish:	• Static dissipative high-pressure laminate with integral trim • Static dissipative vinyl with optional vinyl trim • Conductive vinyl with optional vinyl trim • Other surfaces available by special order
Fire Resistance:	• Non-combustible

Panel Options

- Damper

Understructure Options

- Understructure is available from 6" (152mm) to 68" (1727mm) finished floor heights.
- One pedestal head addresses field and perimeter applications.
- Seismic options are also available.
- For non-standard pedestal options, please contact your Haworth representative.
- Stringers are available in 2' (610mm) and 4' (1219mm) lengths.
- Shims may be required when a 1 $\frac{1}{8}$ " laminate airflow panel will be used next to a 1 $\frac{1}{8}$ " HPL on solid standard panels.

Companion Products and Systems

- Haworth furniture and wall systems.

TecCrete Airflow Panel Performance Ratings**

Access Floor Performance Ratings	Dynamic Load Rating		Static Load Rating
	ROLLING 10 PASSES	ROLLING 10,000 PASSES	CONCENTRATED PSI
TecCrete Airflow	1000 lbs.	650 lbs.	1250 lbs.

*At 12 finished floor height with stringers and without floor coverings.

**10-pass and 10,000-pass rolling load ratings allow for maximum 0.040 permanent set. Rolling, concentrated, and ultimate concentrated load tests performed according to "Recommended Test Procedures for Access Flooring" as established by the Ceiling and Interior Systems Construction Association (CISCA).

TecCrete Low-Profile Pedestal Assembly

Low-profile pedestals are used to support TecCrete 1 1/8" floor panels with 3" (76mm), 4" (102mm), or 5" (127mm) finished floor heights. Cornerlock pedestals are used where four panel corners meet in a floor layout. Perimeter heads support TecCrete panels that are used against a perimeter wall, or where two different types of floors meet.

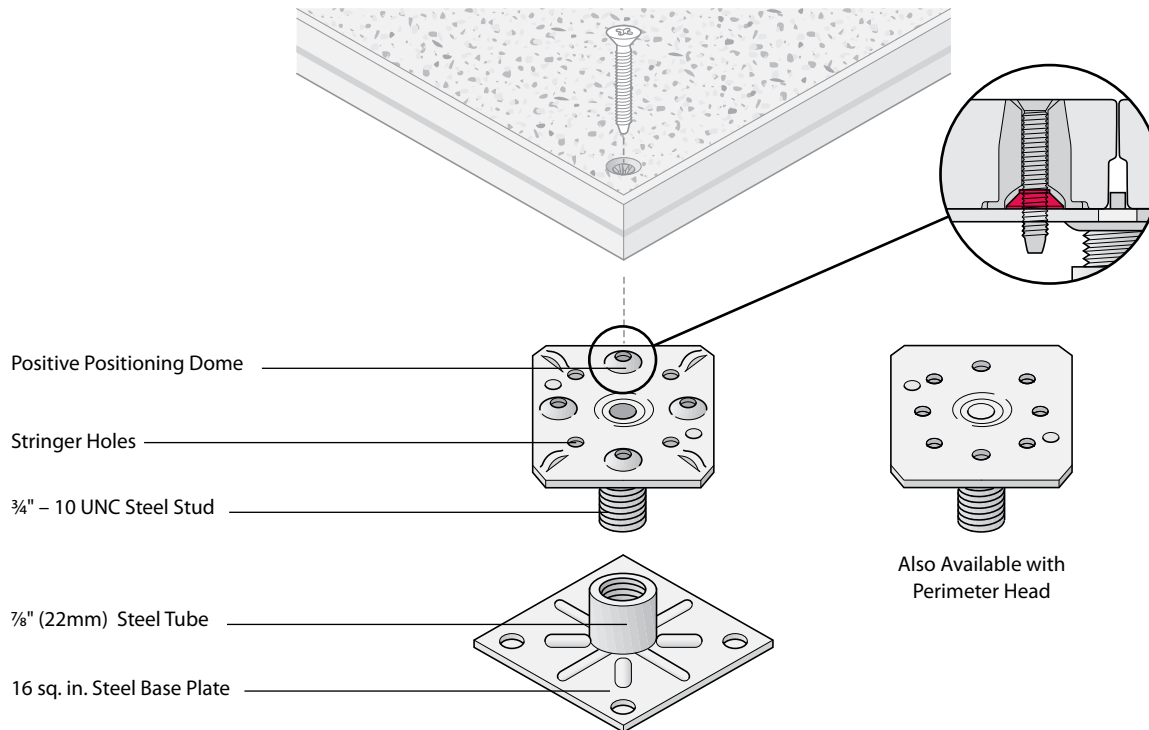

TecCrete Low-Profile Pedestal Assembly

Stability

When recommended pedestal adhesive is used on a clean, unsealed concrete slab, pedestal assemblies have an overturning moment of 1,000 inch-pounds (115.6 Nm).

Load Rating

Pedestal assemblies can support a 6,000lb. (2,6689 N) axial load without permanent deformation.

Finished Floor Height: Low Profile Pedestal Assembly

Standard finished floor heights are 3" (76mm), 4" (102mm), and 5" (127mm).

Pedestal Adjustment

Pedestal assemblies provide adjustment of ½" (12.7mm) up, and ½" (12.7mm) down, 1" (25.4mm) total adjustment for leveling, with a minimum finished floor height of 3" (76mm).

Pedestal Base

Pedestal bases are 16 sq. in., and are made of hot-dipped galvanized steel. Pedestal tubes are made of 7/8" (21mm) round hot-dipped galvanized steel.

Pedestal Head

- There are two standard TecCrete head options that can be used with standard cornerlock or seismic pedestal bases:
 - Pedestal head for cornerlock field applications.
 - Pedestal head for perimeter applications.
- Pedestal heads are made in America.
- Pedestal heads are made of die-formed hot-dipped galvanized steel, attached to a threaded rod. The galvanized nut is ¾" – 10 UNC in diameter.
- Pedestal heads have tapped holes for engagement of cornerlock and stringer screws, the heads provide alignment guides and locating points for positioning and containing floor panels with or without use of screws.
- Solid-steel studs are ¾" (19mm) in diameter.

Stringers

Stringers may be connected for additional support of heavy loads or to accommodate gravity-held rigid-grid applications.

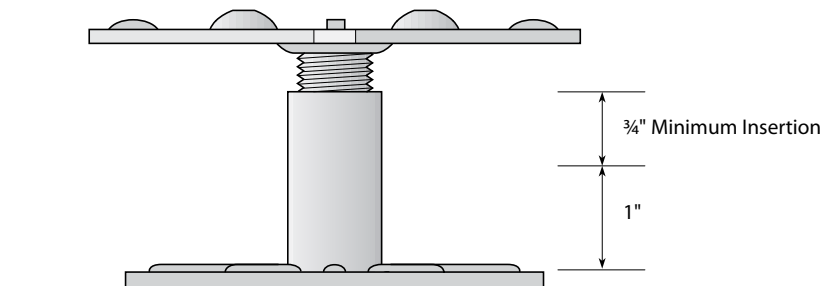

Standard Cornerlock Understructure

Standard cornerlock pedestals are used to support floor panels for 6" to 68" (152mm to 1727mm) finished floor heights. Standard cornerlock pedestals are used to support four panels by their corners. Perimeter heads support TecCrete panels that are used against a perimeter wall, or where two different types of floors meet.

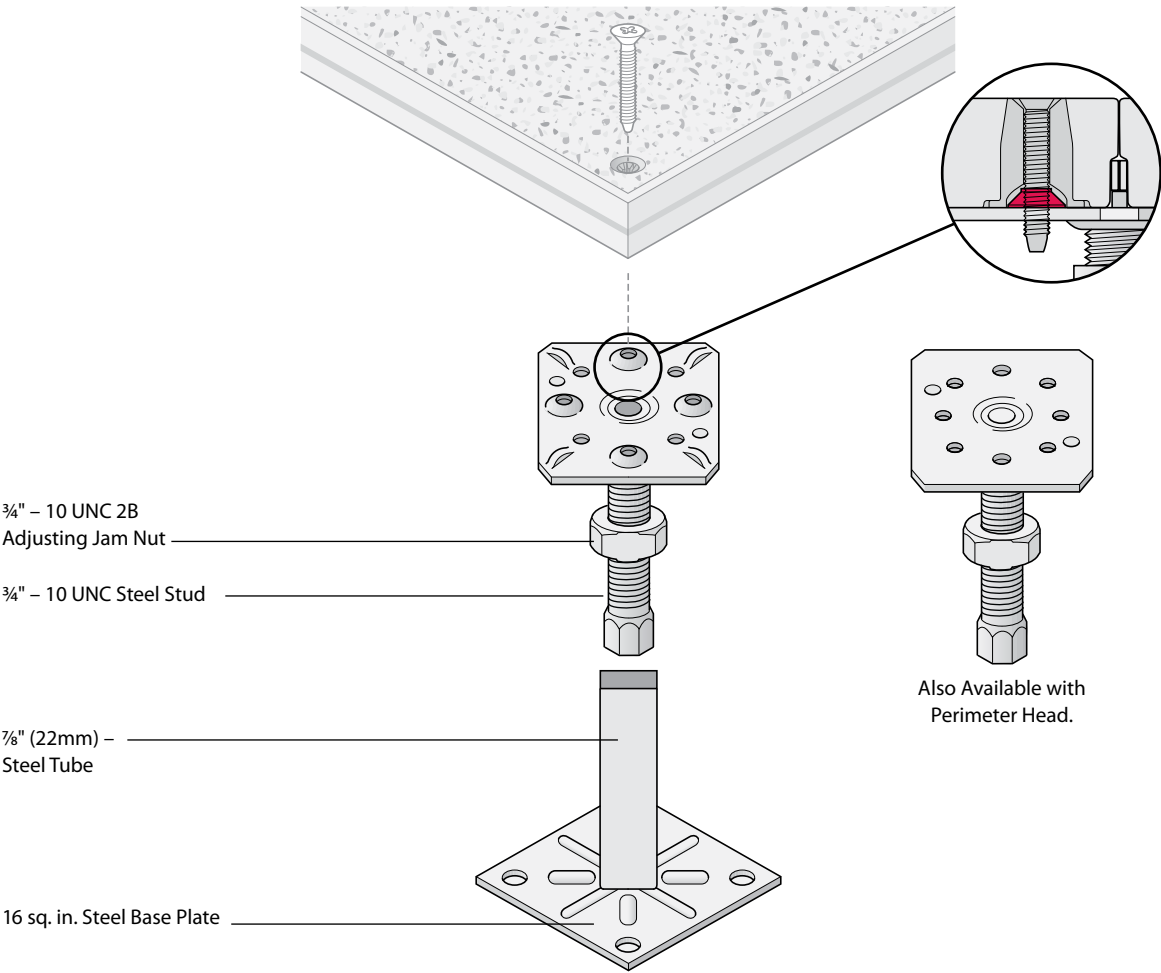

Note Standard pedestal bases are specified separately, for use with your choice of cornerlock field pedestal heads, or perimeter/transition pedestal heads.

Pedestal Bases

General Information

Construction	<ul style="list-style-type: none"> • Pedestal bases are made of hot-dipped galvanized steel to prevent zinc whiskers. • Pedestal tubes are made of 7/8" (21 mm) hot-dipped galvanized steel. • Bases are at least 16" (406mm) square. • Made in America.
Stability and Load Rating	<ul style="list-style-type: none"> • To obtain overturning moment and axial load test values please contact your Haworth representative.
Finished Floor Height	<ul style="list-style-type: none"> • Finished floor heights are 6" to 68" (152mm to 1727mm). Other heights available.
Pedestal Adjustment	<ul style="list-style-type: none"> • Pedestal assemblies provide an adjustment range of ± 1" (25mm) when finished floor height is 6" (152mm) or more, adjustable at 1/64" (0.4mm) increments. • Minimum finished floor height is 6" (152mm) for TecCrete 1250/1500 without stringers, or 7" (178mm) for TecCrete 1250/1500 with stringers. TecCrete 2000/2500 will be a minimum of 7 3/8" with stringers.
Pedestal Head	<ul style="list-style-type: none"> • There are two standard TecCrete head options that can be used with standard cornerlock or seismic pedestal bases: <ul style="list-style-type: none"> - Pedestal head for field applications. - Pedestal head for perimeter applications. • Pedestal heads are made of steel with bright zinc finish attached to a threaded tube with a galvanized 3/4" diameter - 10 UNC nut. • Pedestal heads have tapped holes for engagement of cornerlock and stringer screws, the heads provide alignment guides and locating points for positioning and containing floor panels with or without use of screws. • Solid-steel studs are 3/4" (19mm) in diameter.
Head Options (Specified Separately)	<ul style="list-style-type: none"> • Perimeter pedestals are also available to support floor panels adjacent to columns and walls.
Stringers	<ul style="list-style-type: none"> • Stringers may be connected for additional support of heavy loads, or to accommodate gravity-held rigid-grid applications..

Note When stringers are used, pedestal bases must be specified 1" shorter for any floor height.

Pedestal Base Dimensions

BASE TYPE	FINISHED FLOOR HEIGHT RANGE	MIN. FINISHED FLOOR HEIGHT	SQUARE BASE DIMENSIONS	TUBE DIAMETER (OUTSIDE)	TUBE LENGTH	PEDESTAL ADJUSTMENT	ADJUSTMENT INCREMENTS
Type 0	6" to 30" (152mm to 762mm)	6" (152mm)	4" x 4" x 0.0994" (102mm x 102mm x 3mm)	0.875" square (22mm)	3" to 27" (76mm to 686mm)	±1" (±25mm)	1/64" (0.4mm)
Type 1	6" to 30" (152mm to 762mm)	6" (152mm)	5" x 5" x 0.1853" (102mm x 102mm x 5mm)	0.875" square (22mm)	3" to 27" (76mm to 686mm)	±1" (±25mm)	1/64" (0.4mm)
Type 2	12" to 30" (305mm to 762mm)	12" (305mm)	4" x 4" x 0.0994" (102mm x 102mm x 3mm)	1.163" (29.54mm)	9" to 27" (229mm to 686mm)	±1" (±25mm)	1/64" (0.4mm)
Type 3	12" to 30" (305mm to 762mm)	12" (305mm)	5" x 5" x 0.1853" (127mm x 127mm x 5mm)	1.163" (29.54mm)	9" to 27" (229mm to 686mm)	±1" (±25mm)	1/64" (0.4mm)
Type 4	12" to 30" (305mm to 762mm)	12" (305mm)	6" x 6" x 0.1853" (152mm x 152mm x 5mm)	1.500" (38.1mm)	9" to 27" (229mm to 686mm)	±1" (±25mm)	1/64" (0.4mm)
Type 5	12" to 30" (305mm to 762mm)	12" (305mm)	6" x 6" x 0.25" (152mm x 152mm x 6mm)	1.500" (38.1mm)	9" to 27" (229mm to 686mm)	±1" (±25mm)	1/64" (0.4mm)

Rigid Grid Understructure

Rigid Grid and Cornerlock with Bare Panel

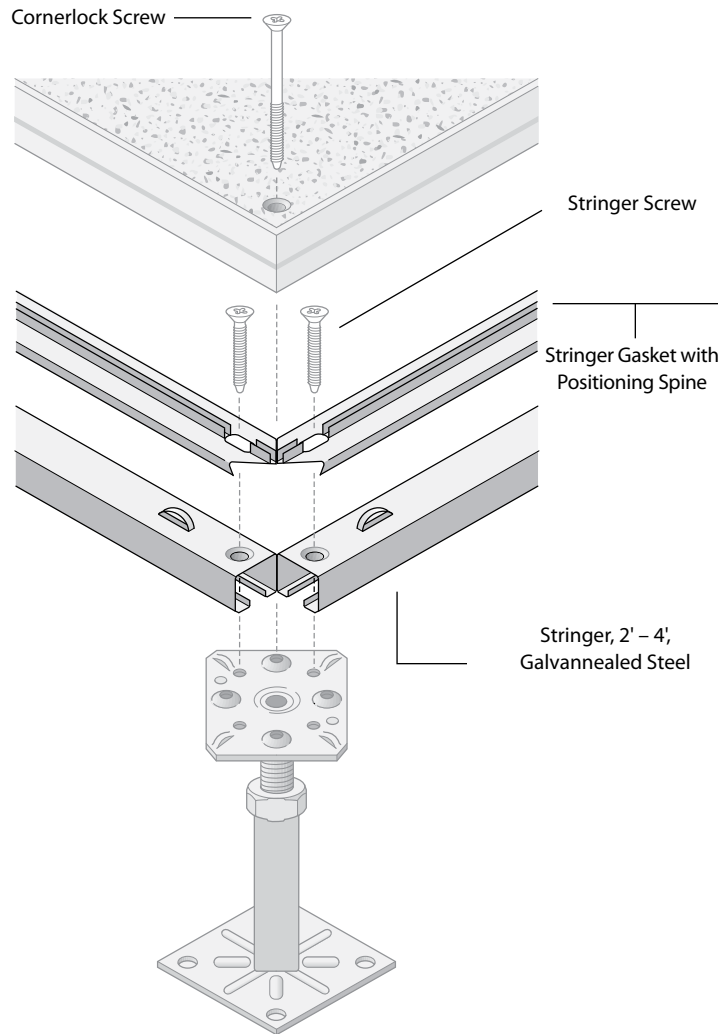

Rigid Grid and Cornerlock with Laminate Panel

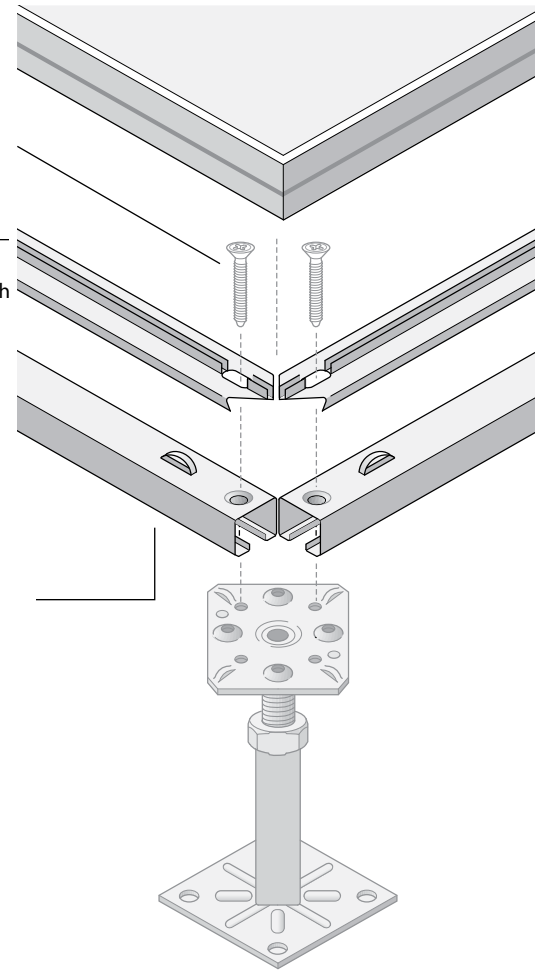

Construction

Stringers are roll formed 16 gauge galvannealed steel.

Load Rating

Stringers can support a concentrated load of 450 lbs (205 kg) at a center of a 24" (610mm) span without exceeding a 0.010" (0.25400mm) permanent set.

Grid Pattern Options

Stringer grid patterns are 2' x 2' (610mm x 610mm), 2' x 4' (610mm x 1219mm), or 4' x 4' (1219mm x 1219mm).

Floor Height

Pedestal bases must be specified 1" (32mm) shorter when using stringers to arrive at the correct finished floor height.

Electrical Grounding

A grounding screw can be used for stringered applications where the panel-to-pedestal resistance is required to be less than 10 ohms.

Understructure Applications

Field Pedestal Attachment without Stringers

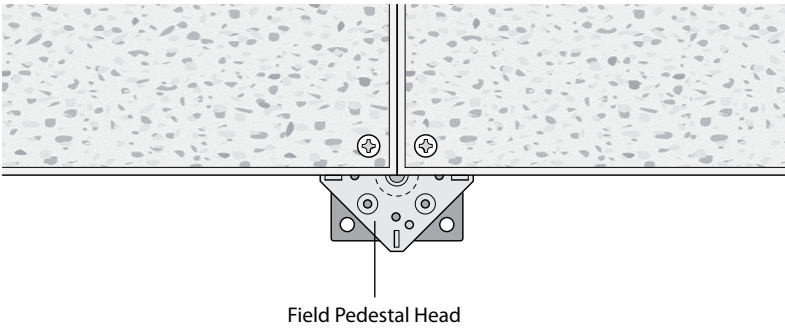

Field Pedestal Attachment with Stringers

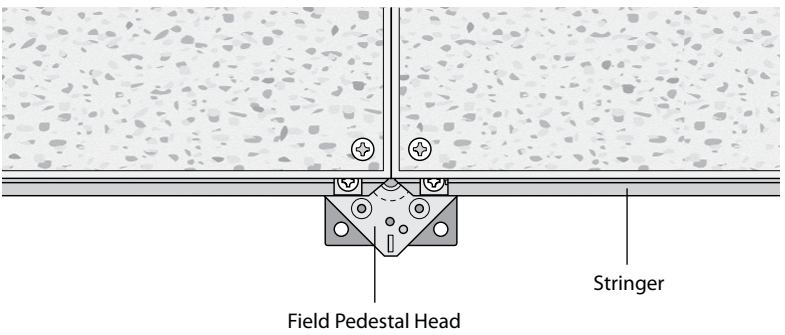

Field Pedestal Attachment Detail without Stringers

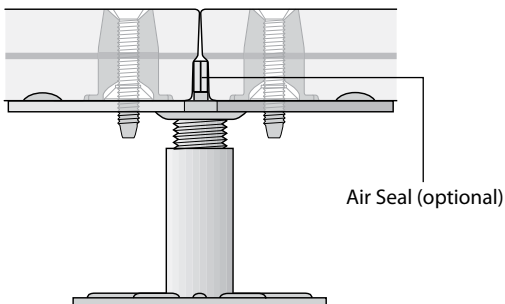

Field Pedestal Attachment Detail with Stringers

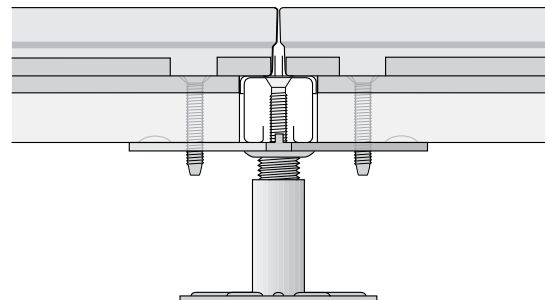

Understructure Applications

Perimeter Wall Condition without Stringers

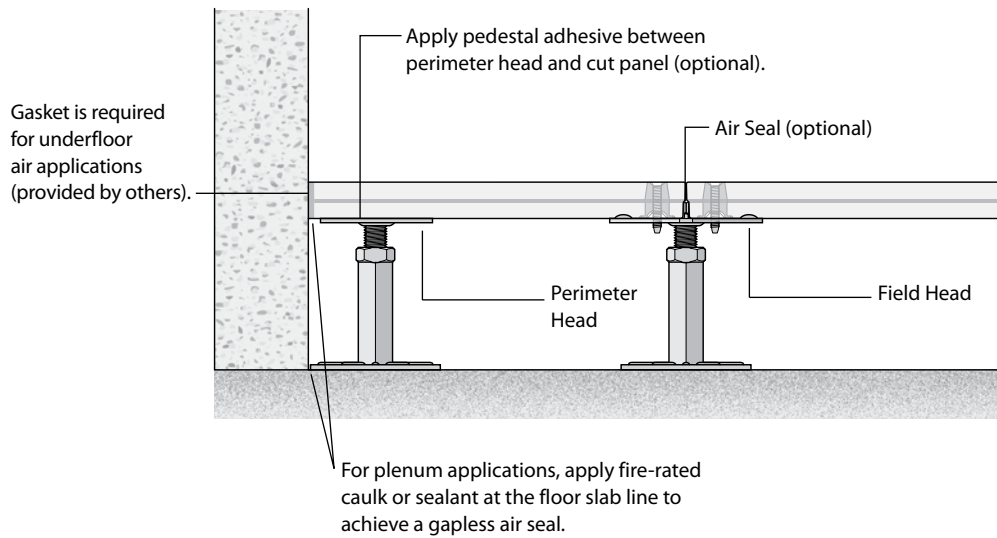

Perimeter Wall Condition with Stringers

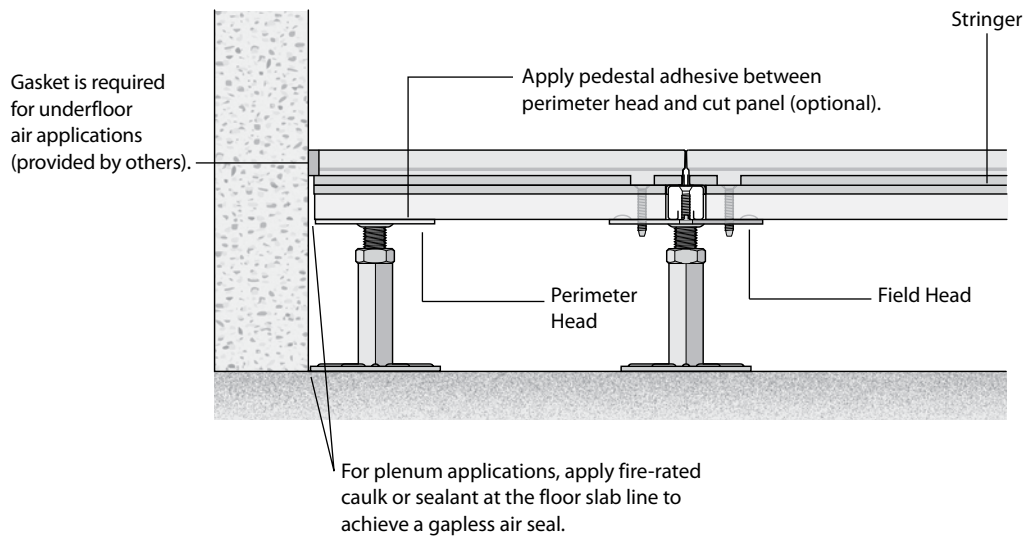

- Notes**
- Perimeter heads should be located as close to the edge of the panel as possible on 24" centers, maximum.
 - For plenum applications not utilizing carpet tile or stringers, an integral air seal may be specified on panels to optimize underfloor air system performance.
 - All application details apply to low and standard height, except where noted.

Cornerlock with Expansion Joint and Expansion Joint Detail

Expansion Joint Application and Detail without Stringers

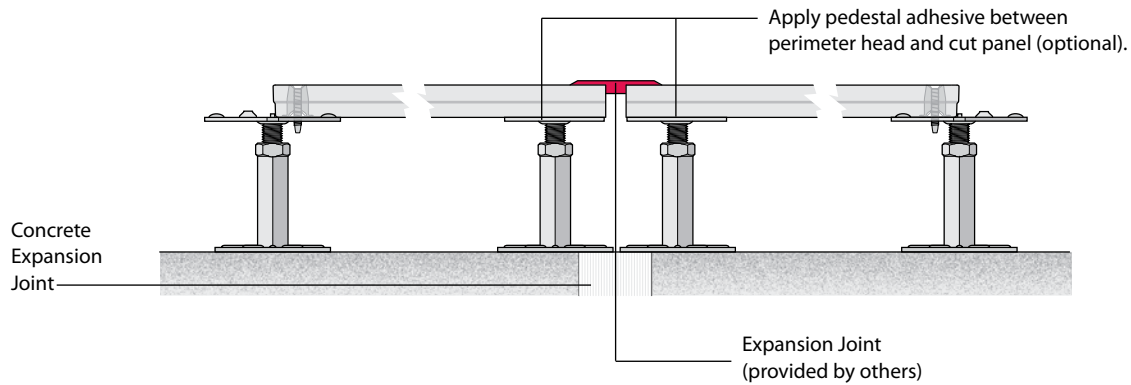

Expansion Joint Application and Detail with Stringers

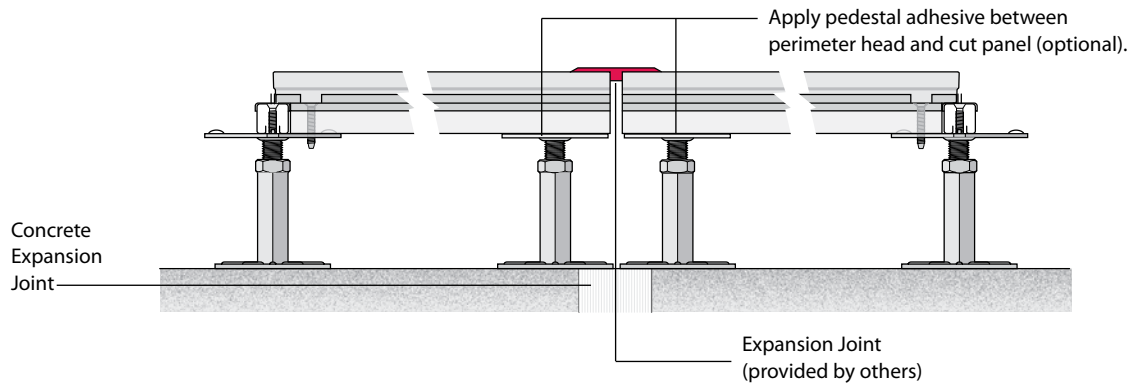

Curb Application without Stringers

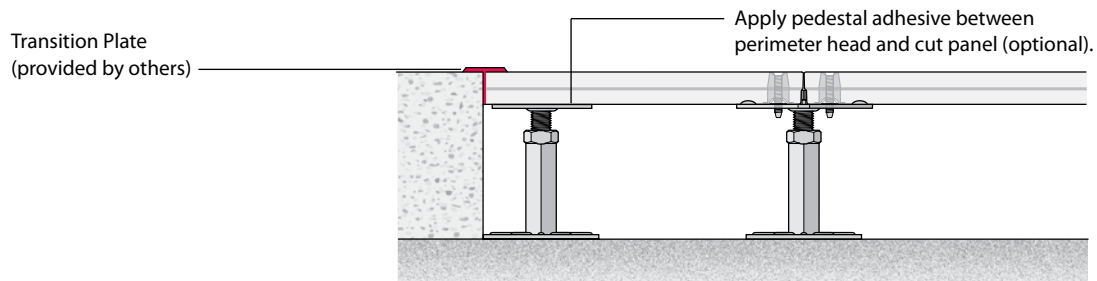

Curb Application with Stringers

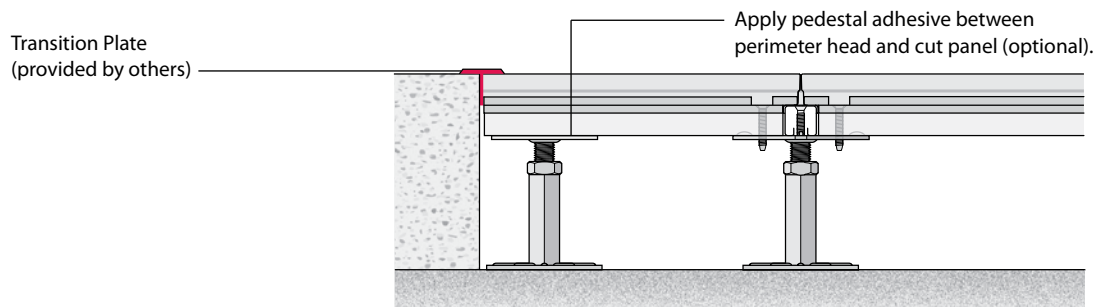

Cornerlock with Expansion Joint and Expansion Joint Detail

Fascia Application without Stringers

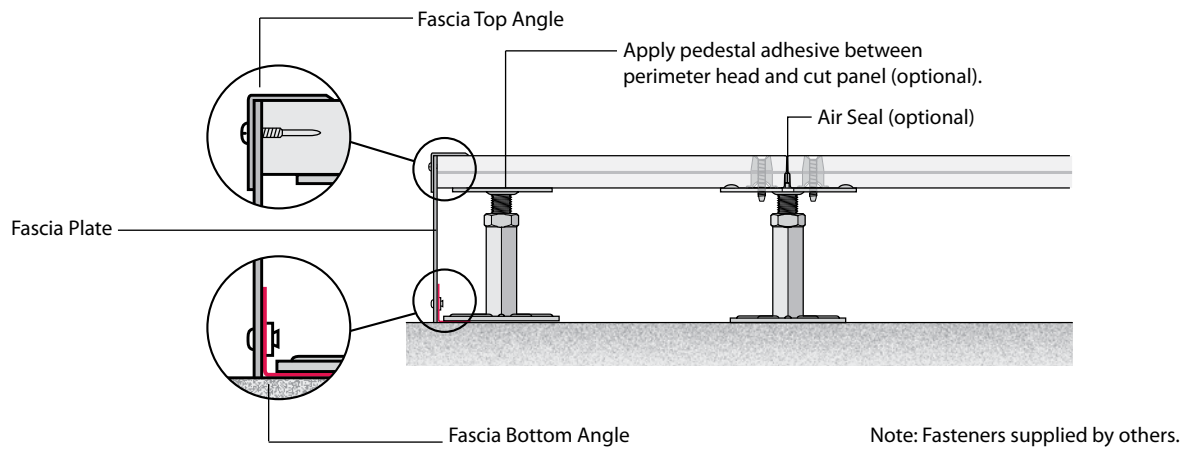

Fascia Application with Stringers

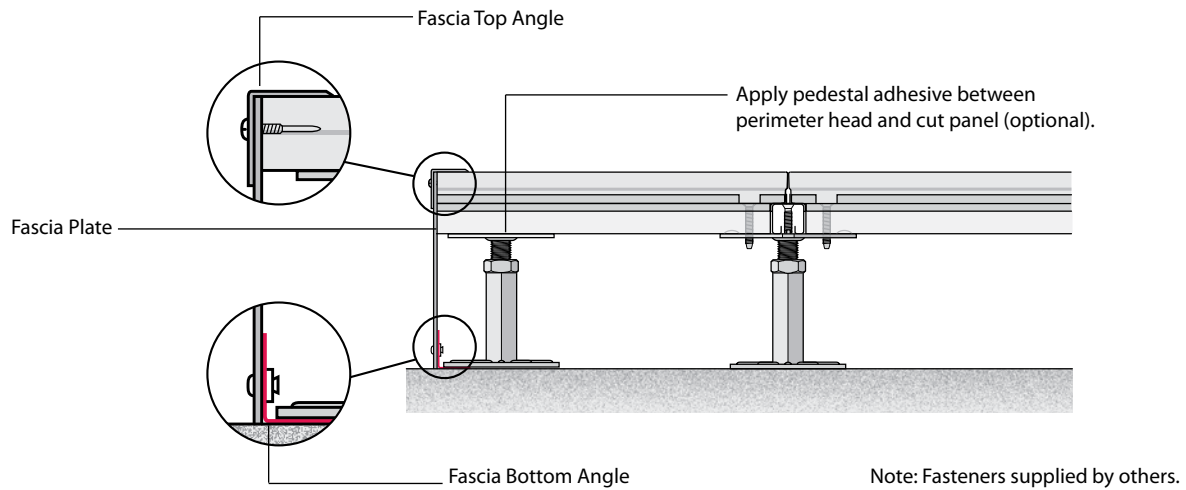

Wall Surface Partition and Doorway Applications

Penetrating Wall without Stringers

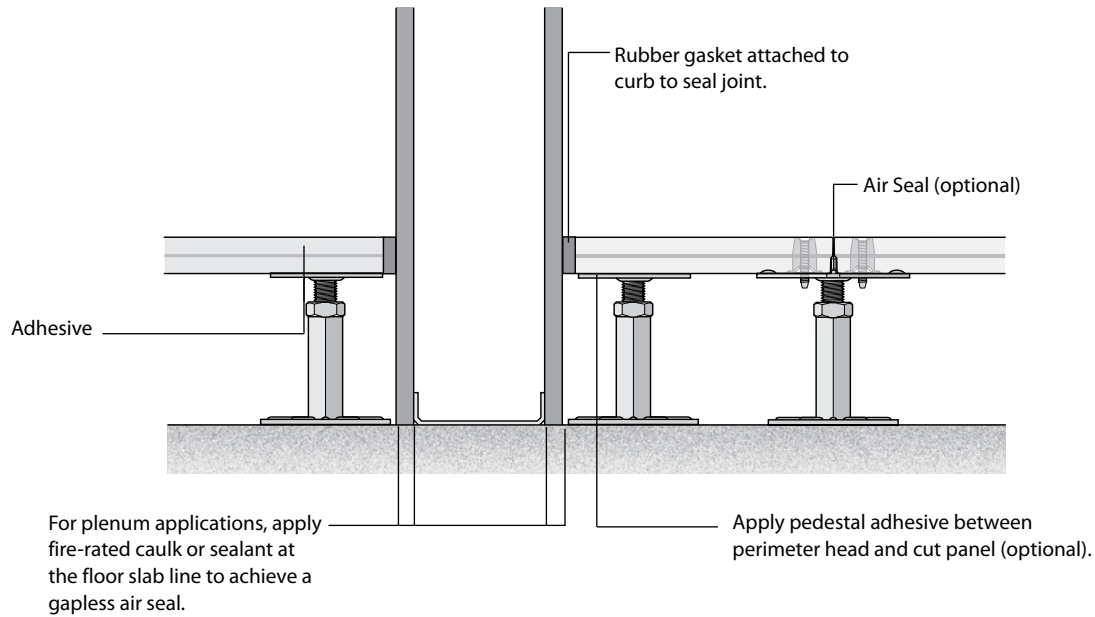

Note For plenum applications not utilizing carpet tile or stringers, specify an integral air seal on panels to minimize cost and optimize underfloor air system performance.

Penetrating Wall with Stringers

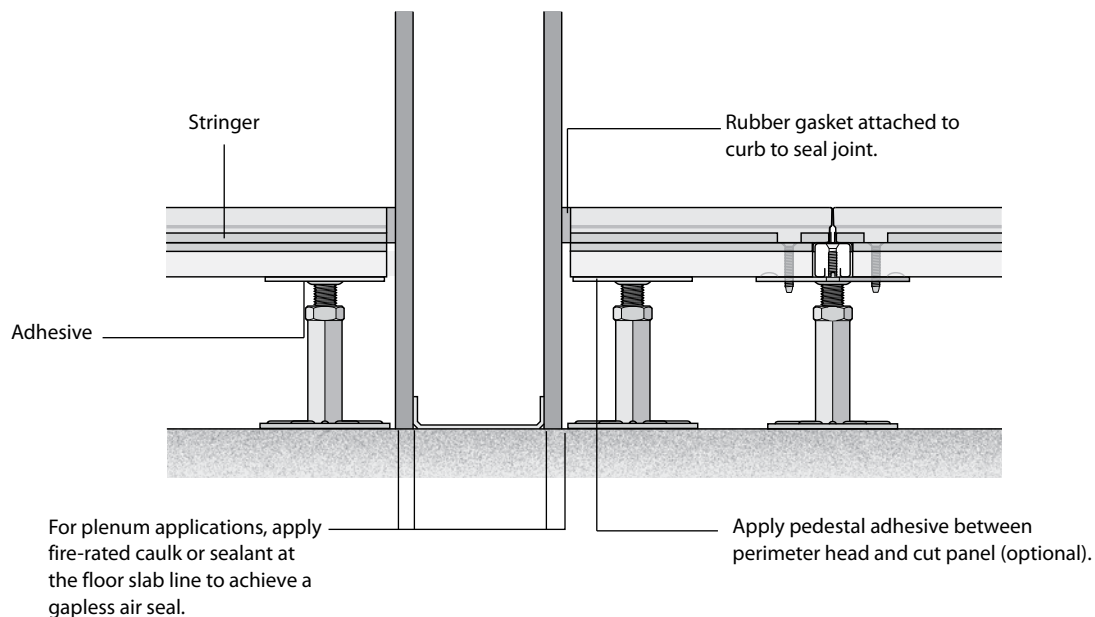

Wall Surface Partition and Doorway Applications

Surface Wall Partition Detail (without Stringers)

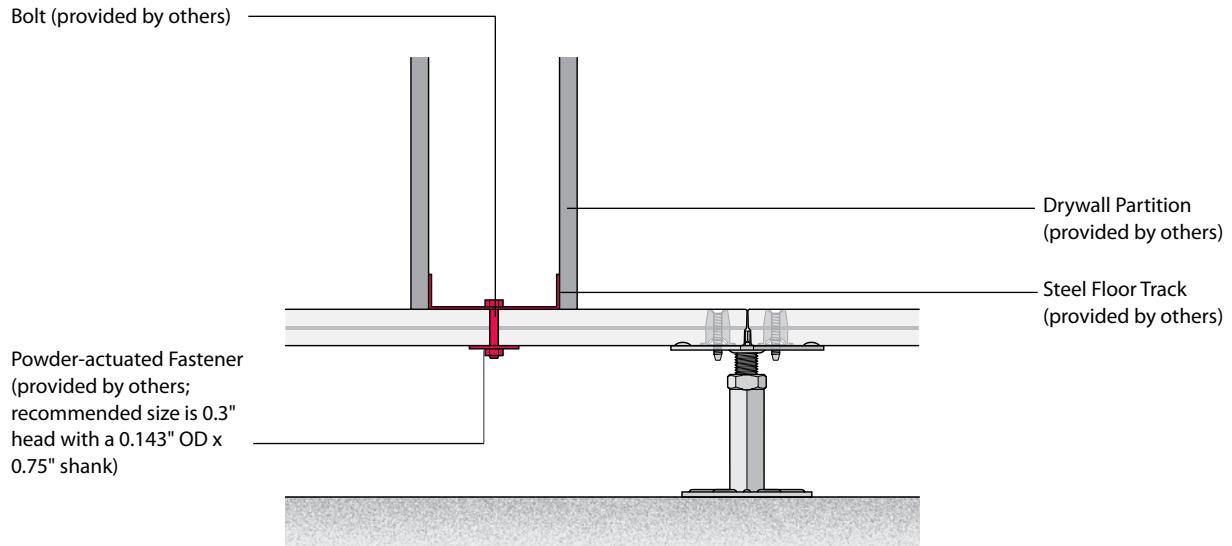

Alternative attachment method: If walls are secured at ceiling level, or stabilized by attached perpendicular walls, then powder actuated pins (with a 0.3" diameter head and a 0.143" diameter $\frac{3}{4}$ " long shank), spaced at 16-inch intervals, can be used to fasten floor track to the surface of the TecCrete panel.

Note For plenum applications not utilizing carpet tile or stringers, specify an integral air seal on panels to minimize cost and optimize underfloor air system performance.

Surface Wall Partition Detail (with Stringers)

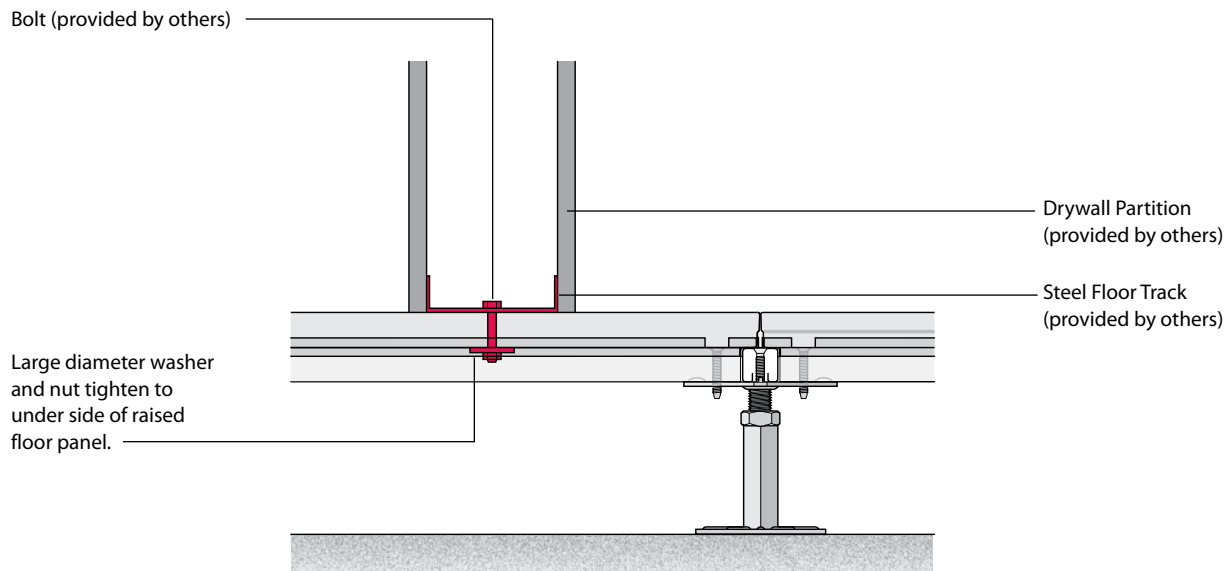

Alternative attachment method: If walls are secured at ceiling level, or stabilized by attached perpendicular walls, then powder actuated pins (with a 0.3" diameter head and a 0.143" diameter $\frac{3}{4}$ " long shank), spaced at 16-inch intervals, can be used to fasten floor track to the surface of the TecCrete panel.

Wall Surface Partition and Doorway Applications

Access Floor Interface at Glass Wall (without Stringers)

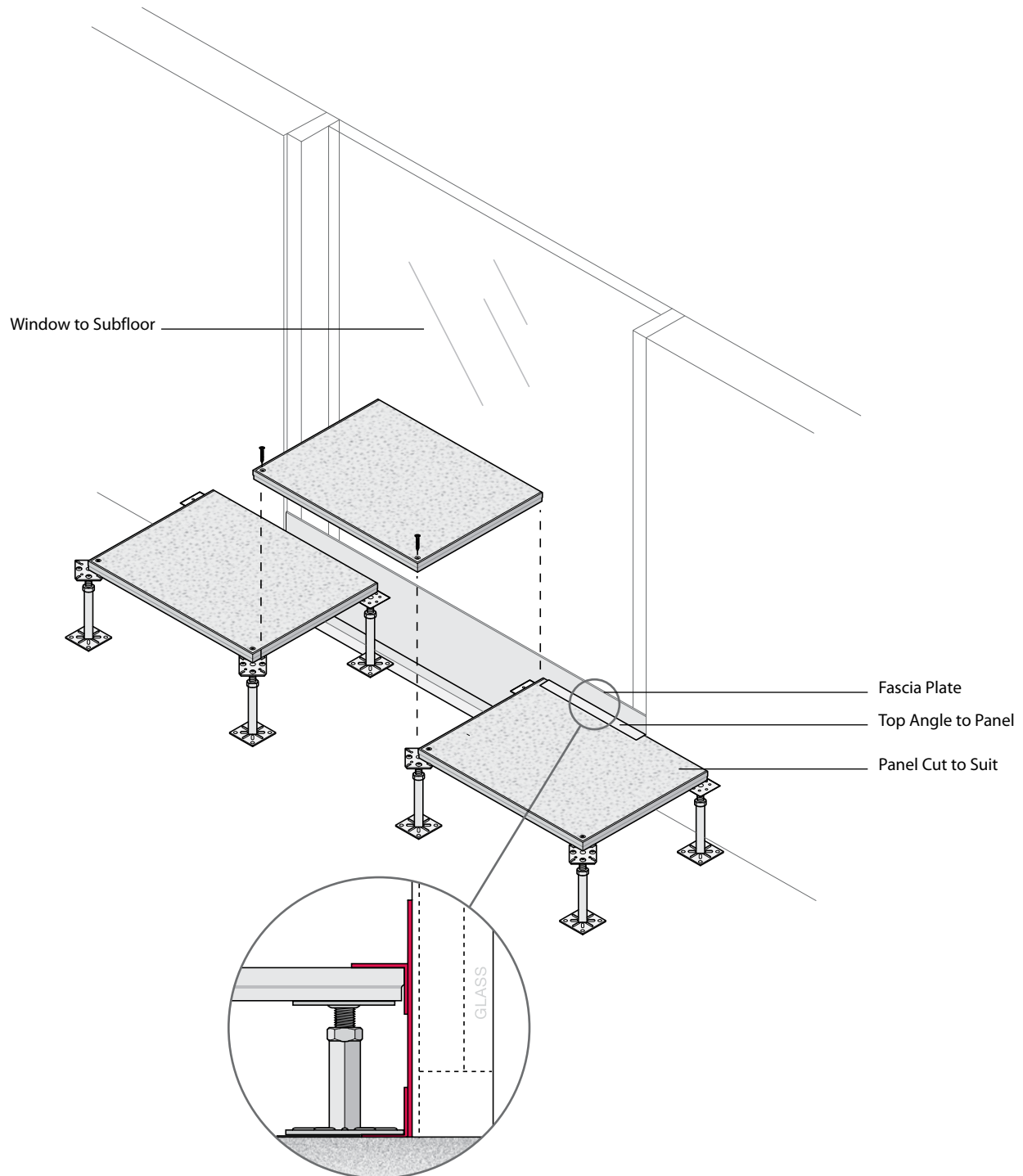

- Notes**
- Apply pedestal adhesive on top of flat pedestal head and cut panel.
 - For plenum applications not utilizing carpet tile or stringers, an integral air seal may be specified on panels to optimize underfloor air system performance.

Wall Surface Partition and Doorway Applications

Access Floor Interface at Glass Doorway: Non-Stringer Application

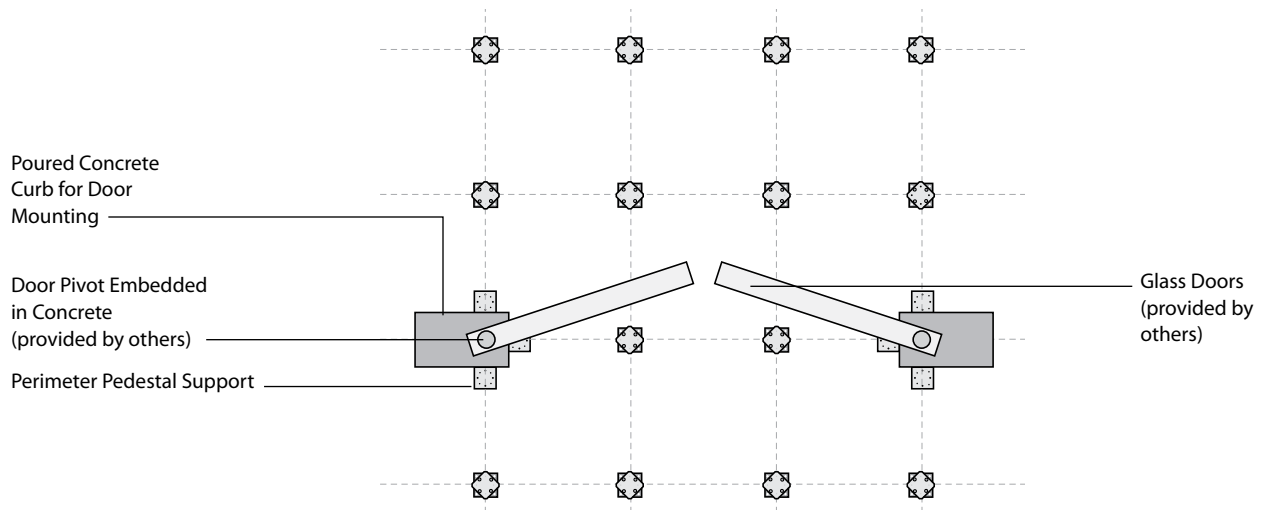

Access Floor Interface at Glass Doorway: Stringer Application

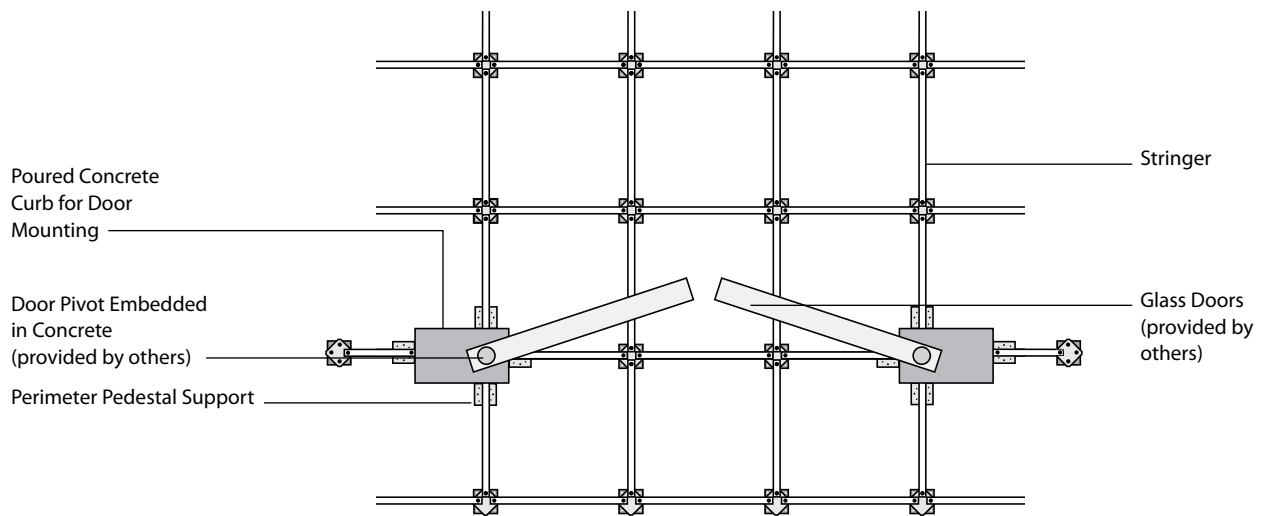

Wall Surface Partition and Doorway Applications

Access Floor Interface at Glass Doorway Detail: Stringer Application

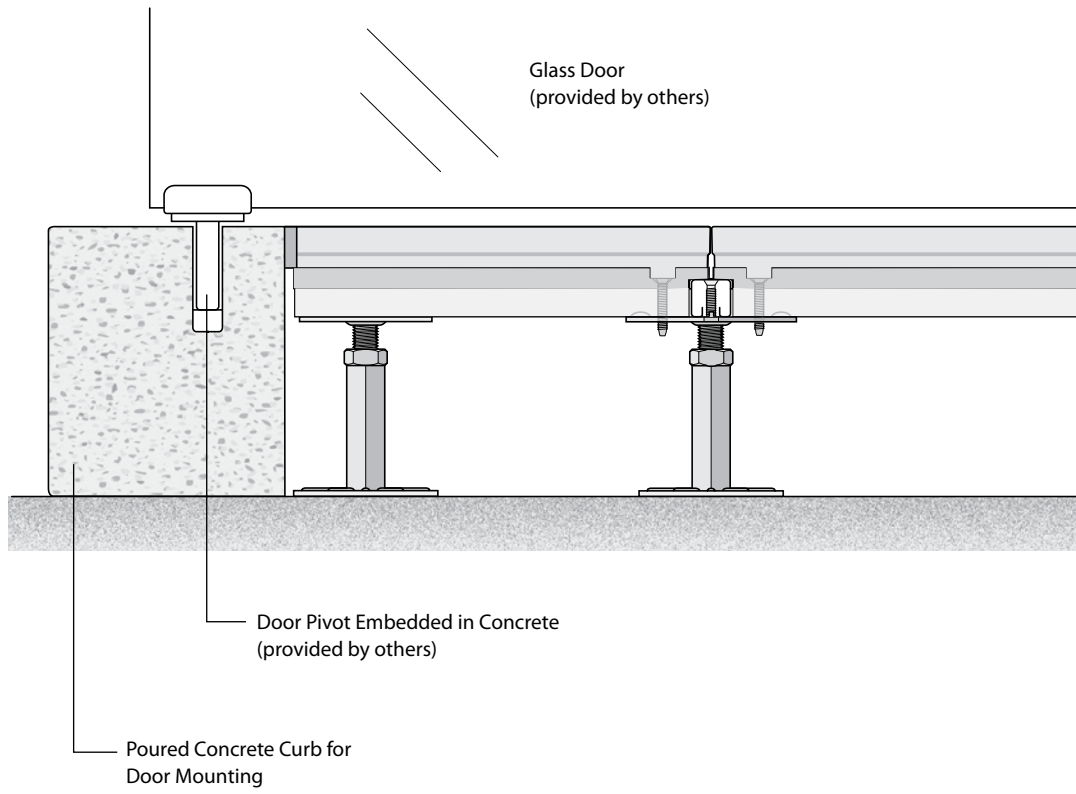

Angled Wall Applications

Perimeter Condition at Angled Wall with Stringers

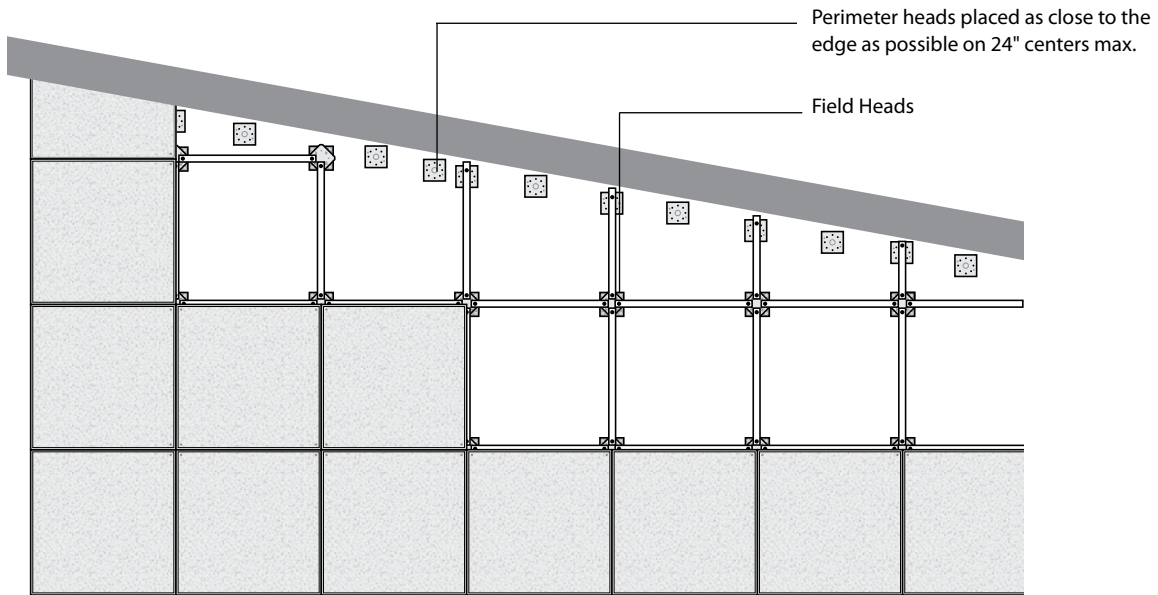

Perimeter Condition at Angled Wall without Stringers

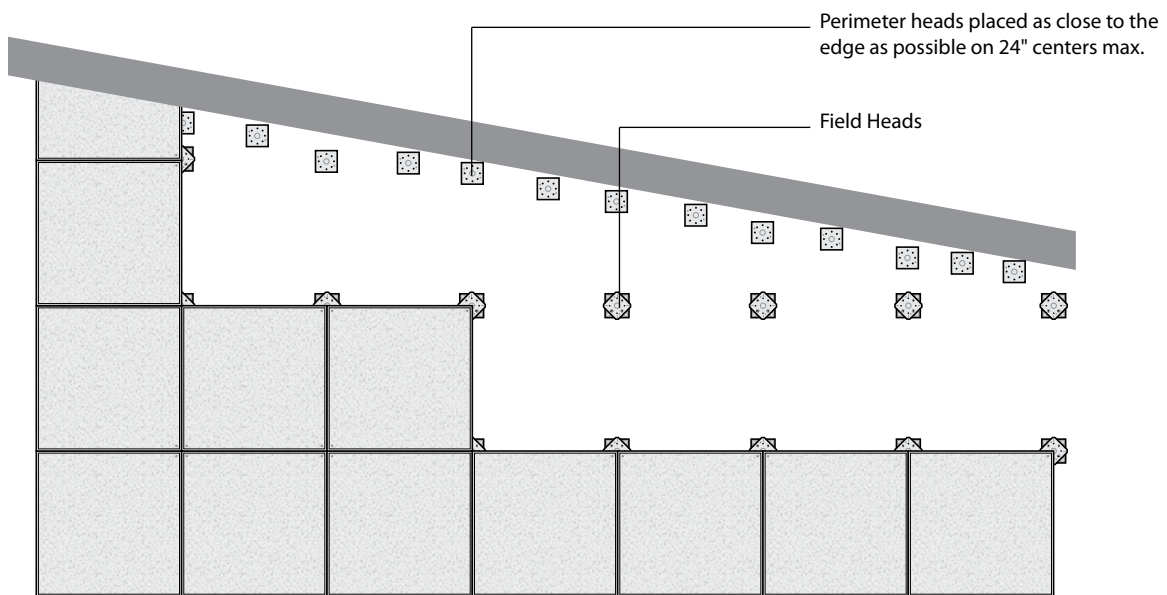

Specialty Floor Finish Applications: Finish Transitions

Bare Panel Application

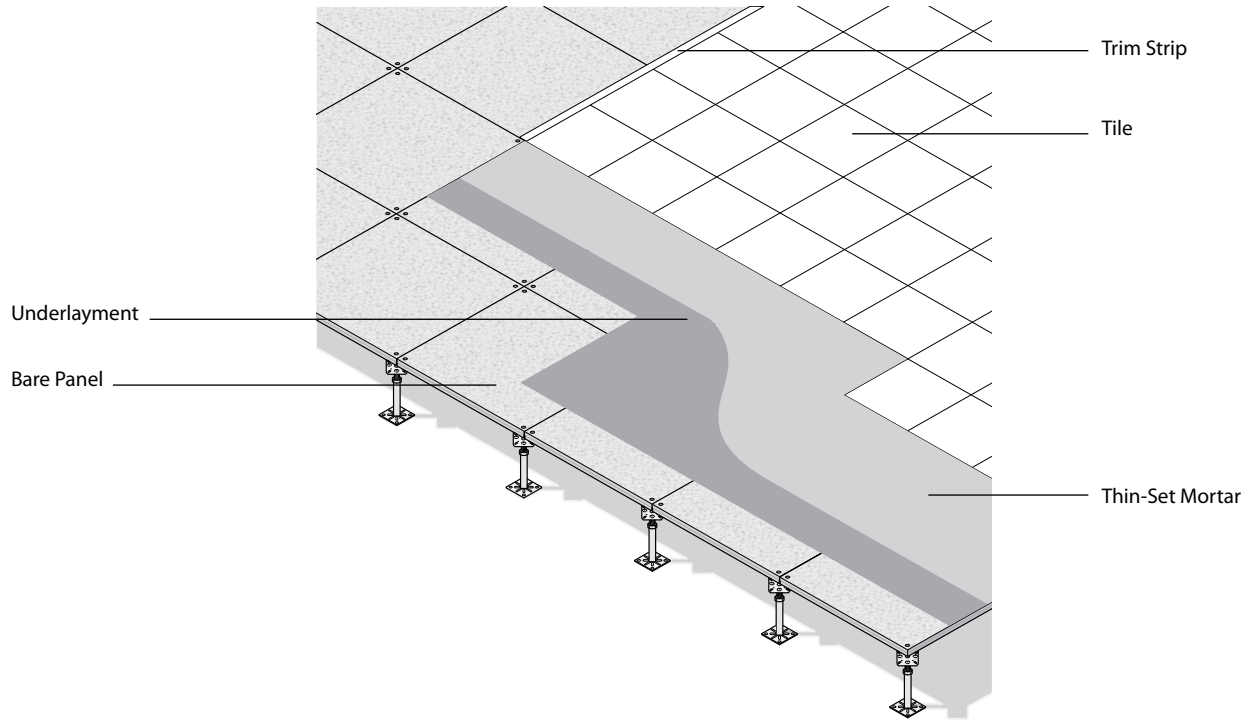

Ceramic Tile/Carpet with Trim Strip Transition

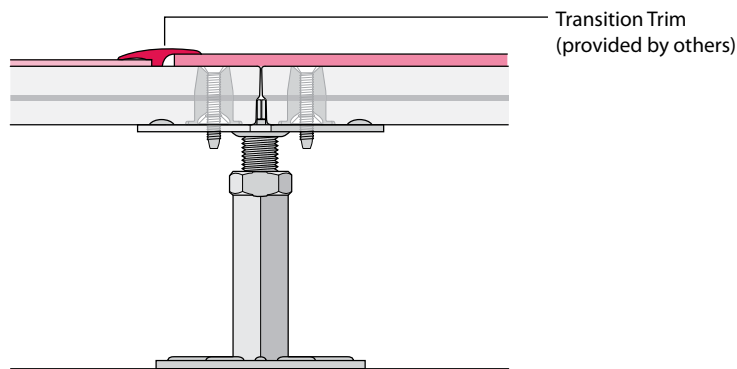

Specialty Floor Finish Applications: Finish Transitions

Transition from Cornerlock to Stringer-Supported Panels

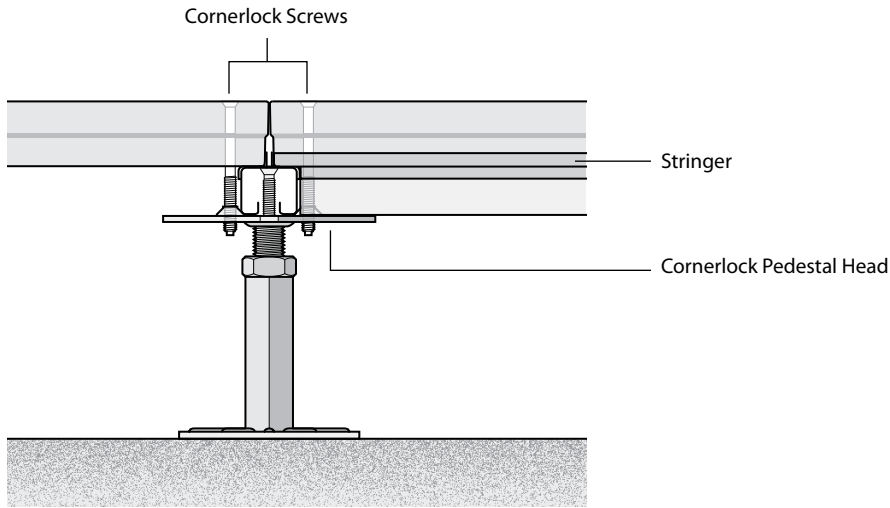

Transition Made Using Adjustable Head without Stringers

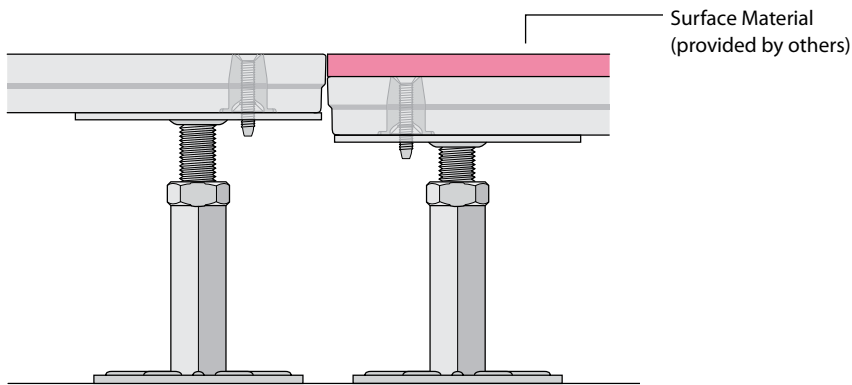

Transition Made Using Adjustable Head with Stringers

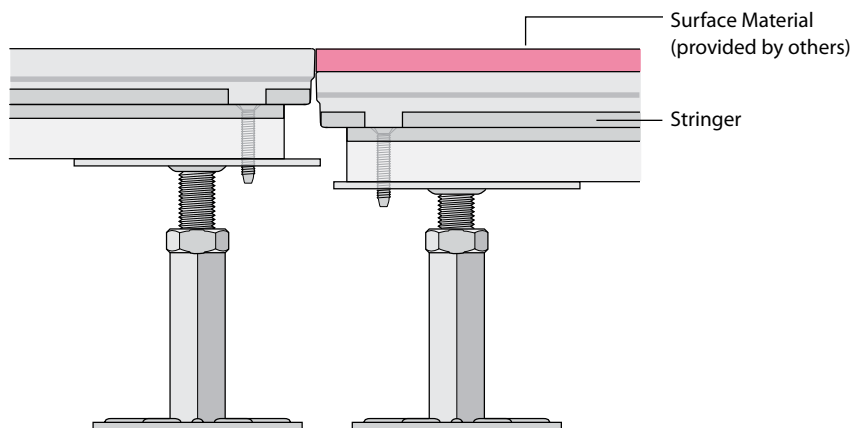

Floor Area Transitions

Transition Between Access Floor Levels

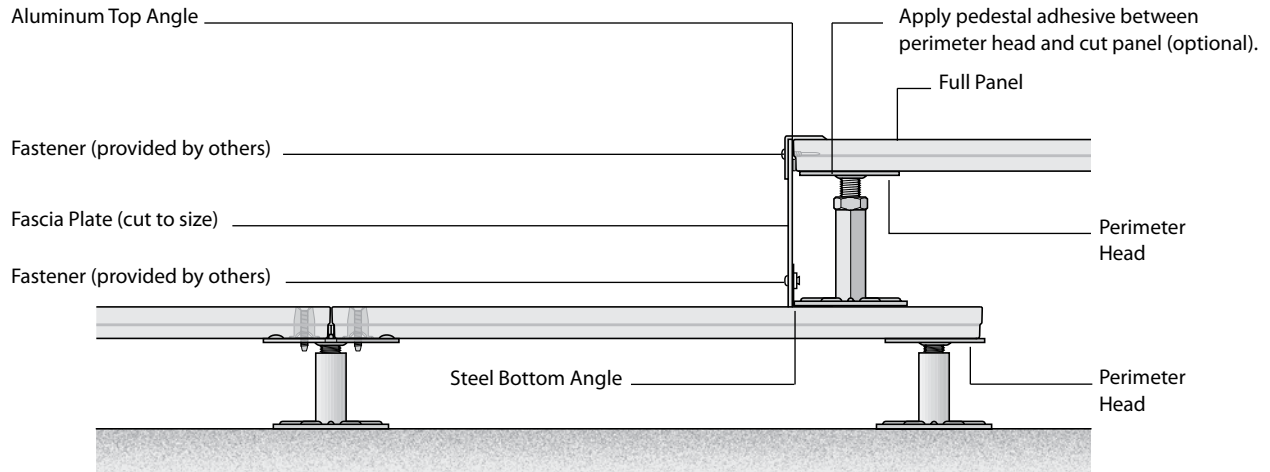

Transition Between Access Floor Levels: Floor Supported

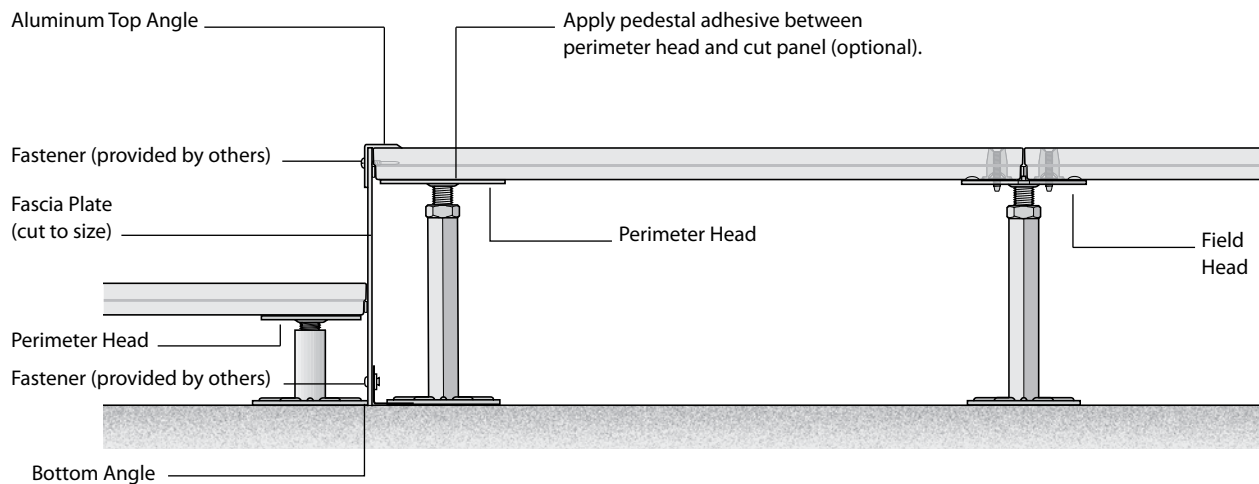

Transition Between Access Floor Levels: Steps

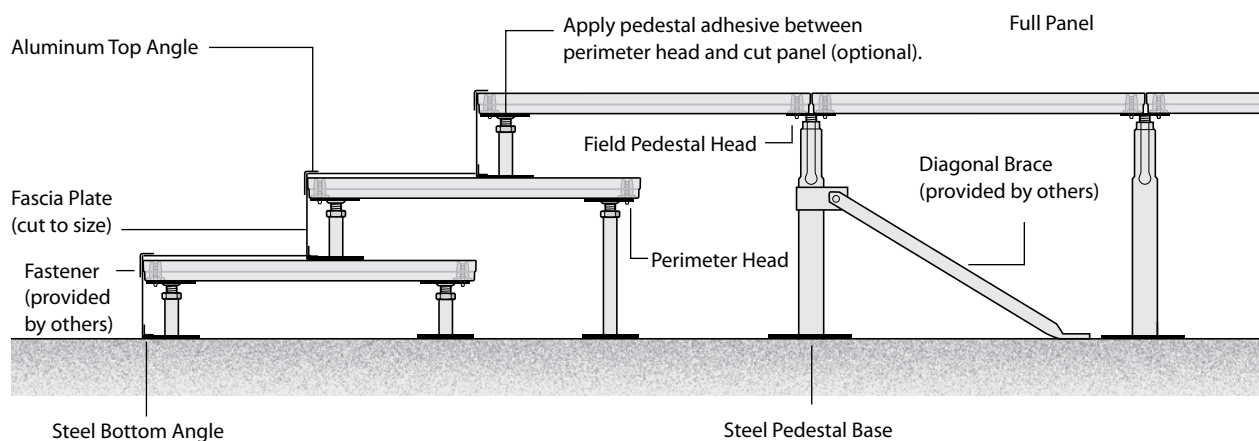

Floor Area Transitions

Step Detail at Recessed Slab

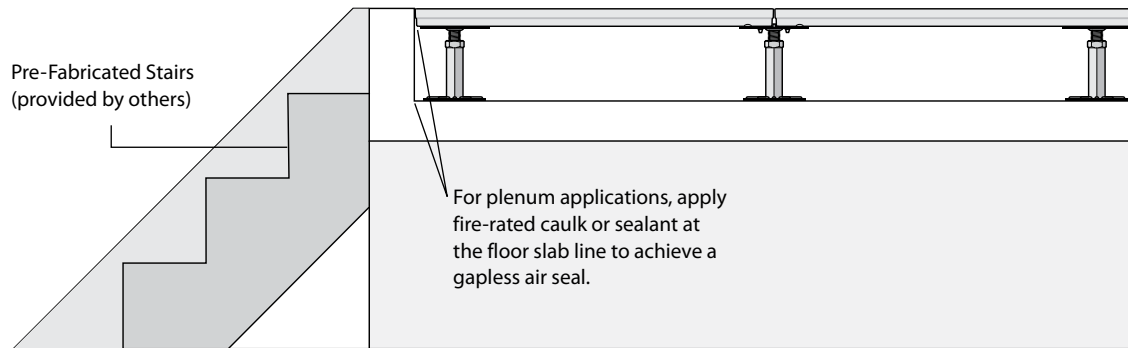

Note For plenum applications not utilizing carpet tile or stringers, an integral air seal may be specified on panels to optimize underfloor air system performance.

Transition from Elevators/On-Slab Doorways

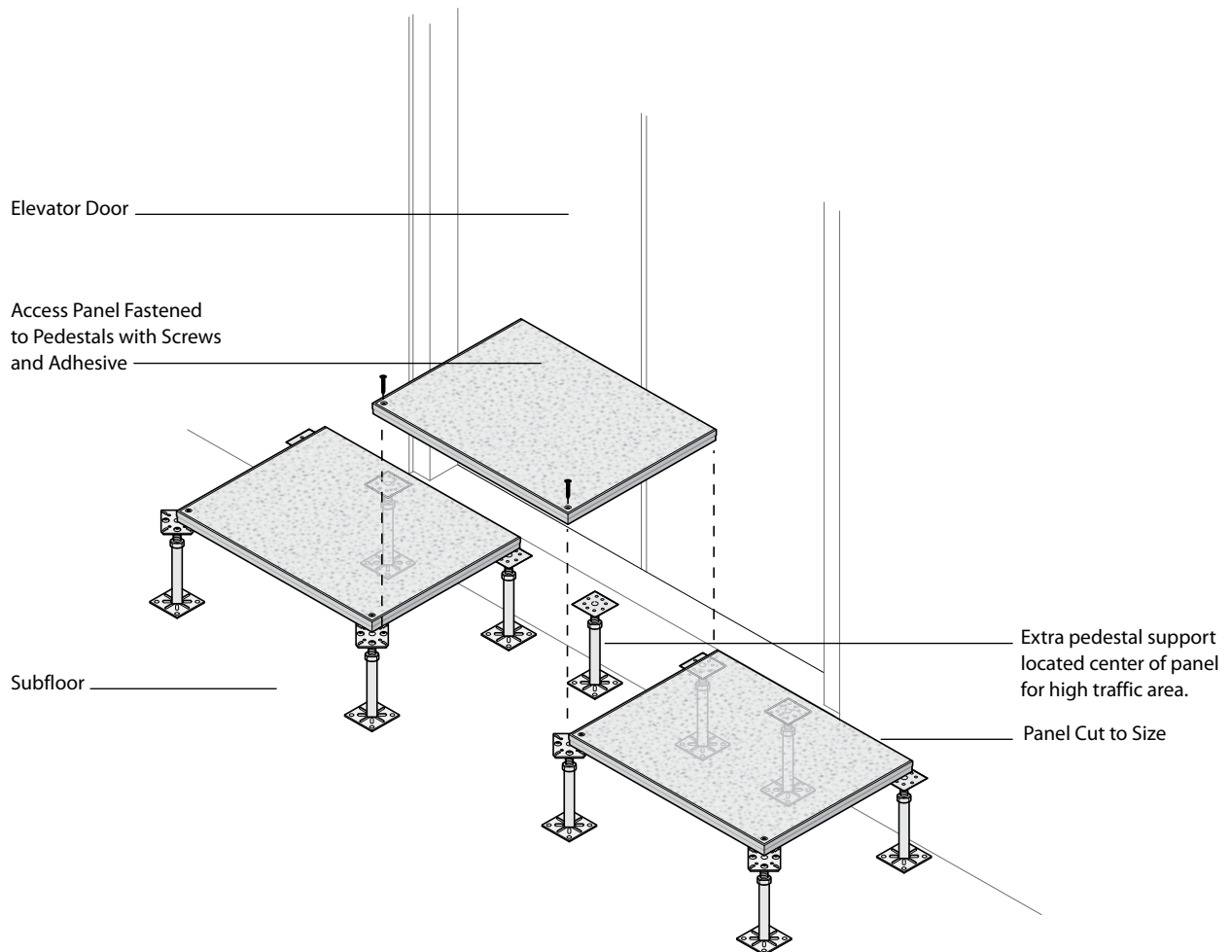

Notes

- Apply pedestal adhesive between perimeter head and cut panel.
- For plenum applications not utilizing carpet tile or stringers, an integral air seal may be specified on panels to optimize underfloor air system performance.

Floor Area Transitions

Transition from Core Area to Access Floor

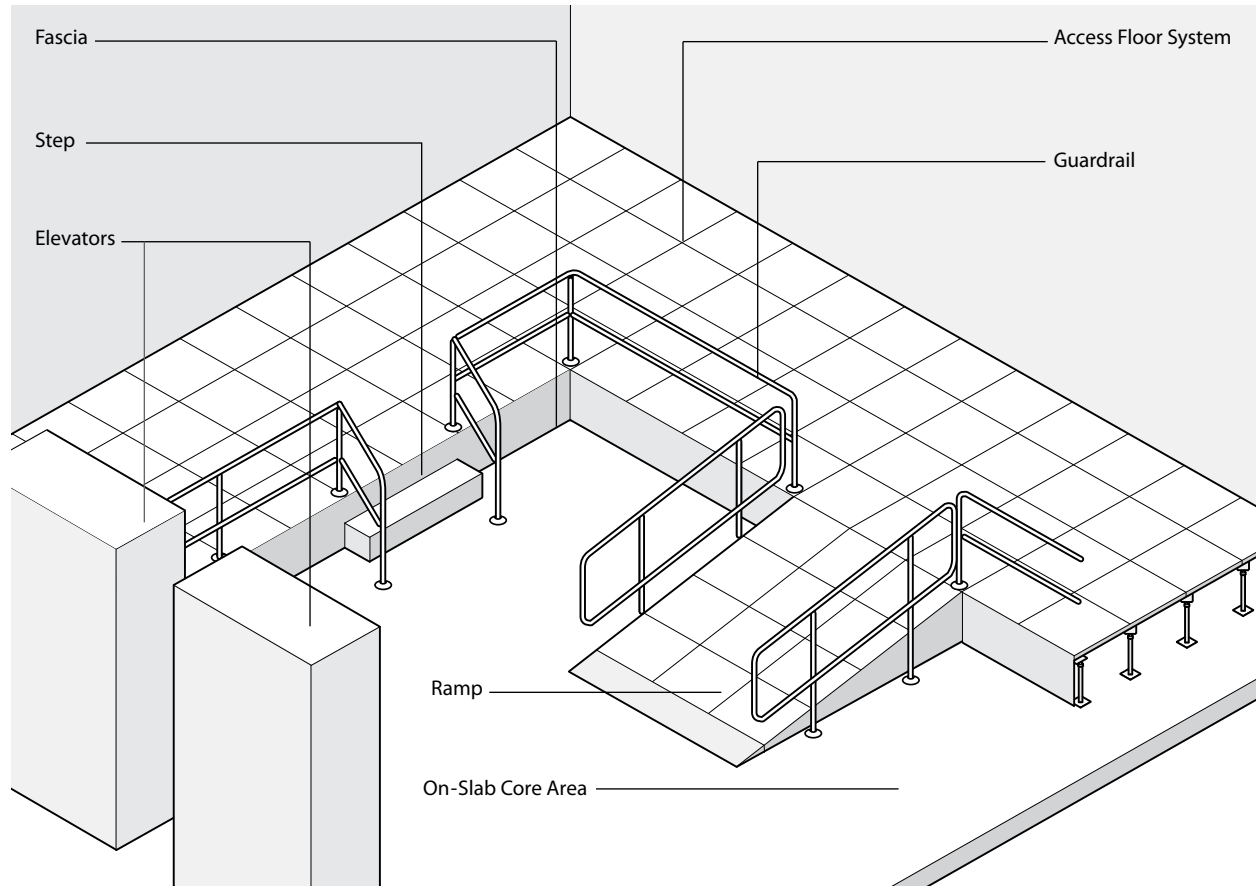

Bridging Obstructions on Subfloors

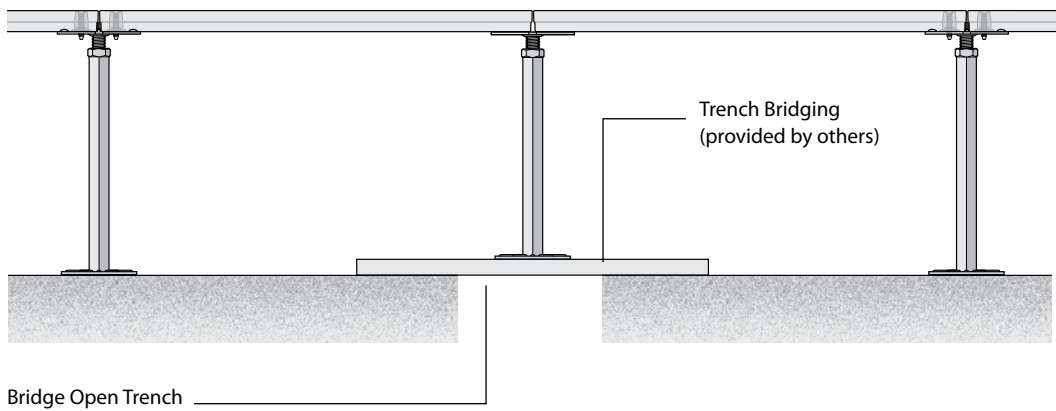
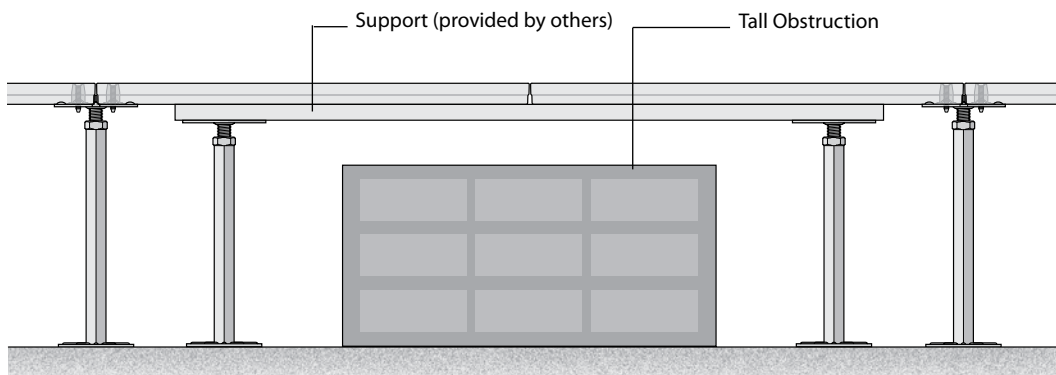
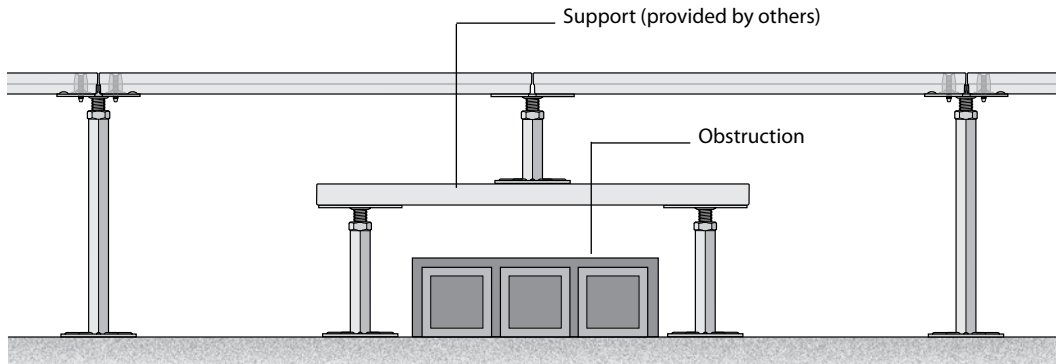

Ramp Details

Ramp without Stringers

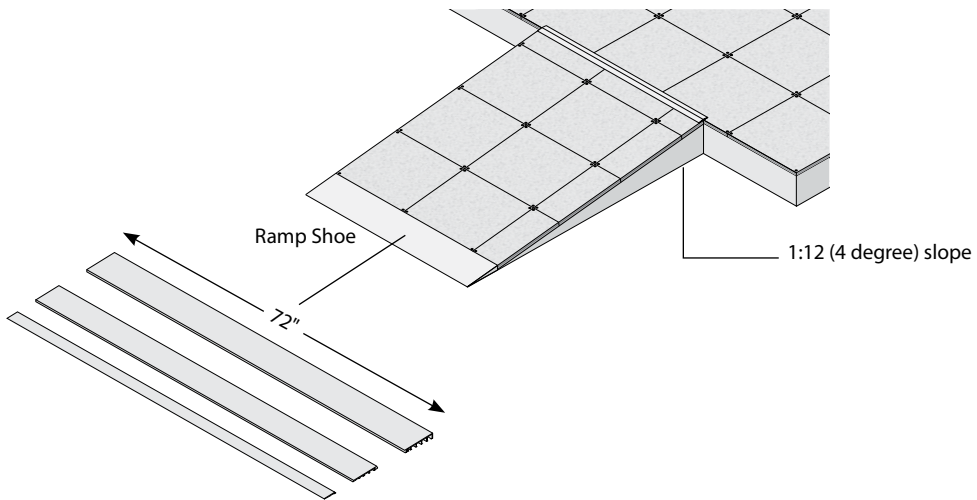
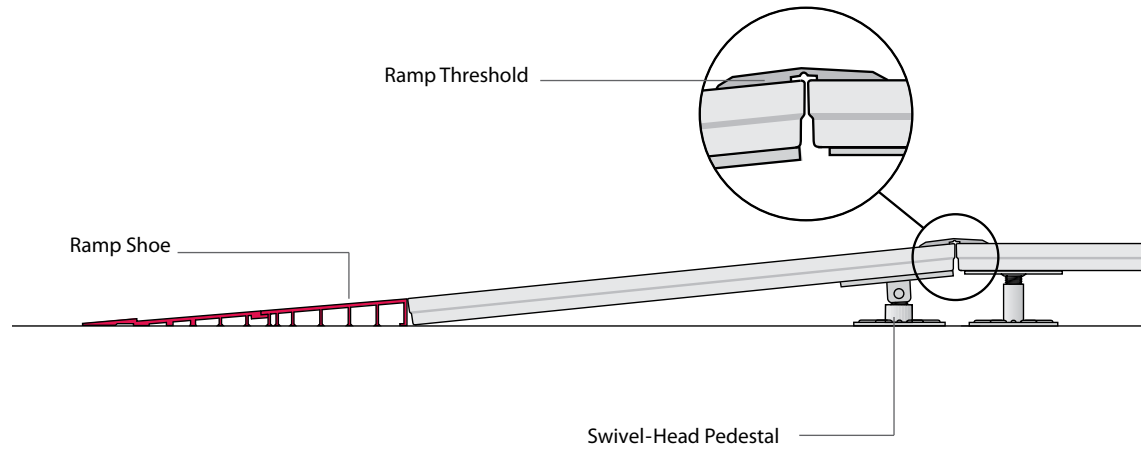

Mounting Equipment to TecCrete Access Floors

Mounting Equipment to Access Floors without Stringers

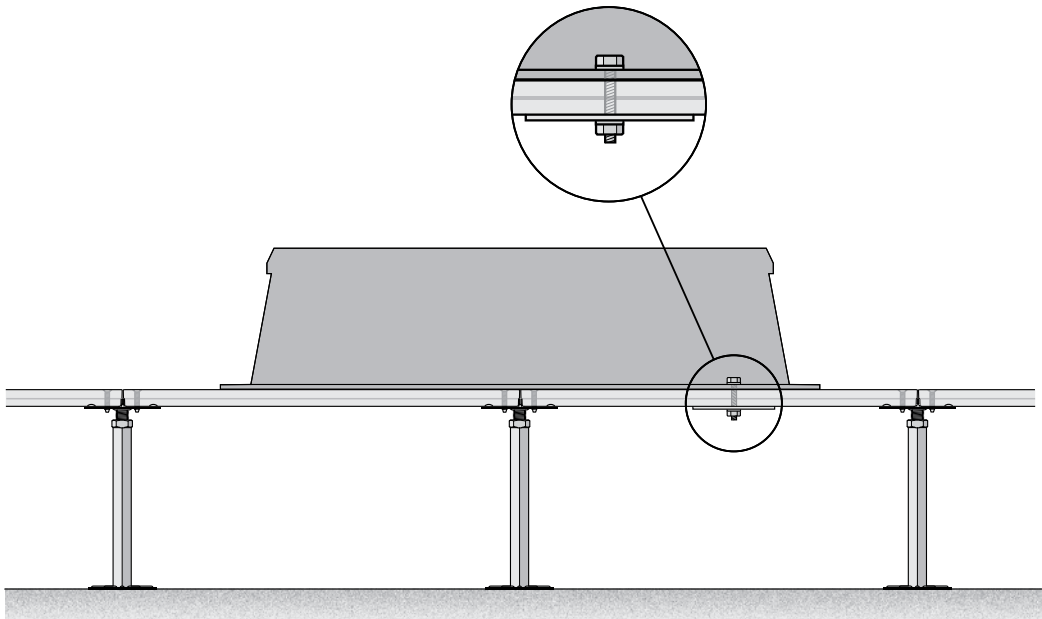

Mounting Equipment to Access Floors with Stringers

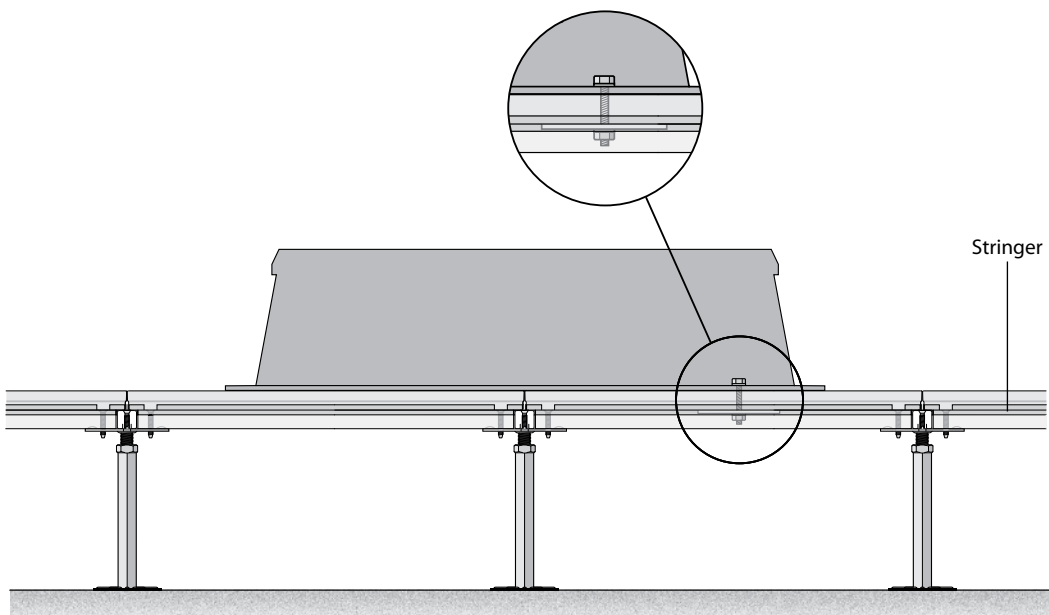

Mounting Equipment to TecCrete Access Floors

Mounting Equipment to Subfloors without Stringers

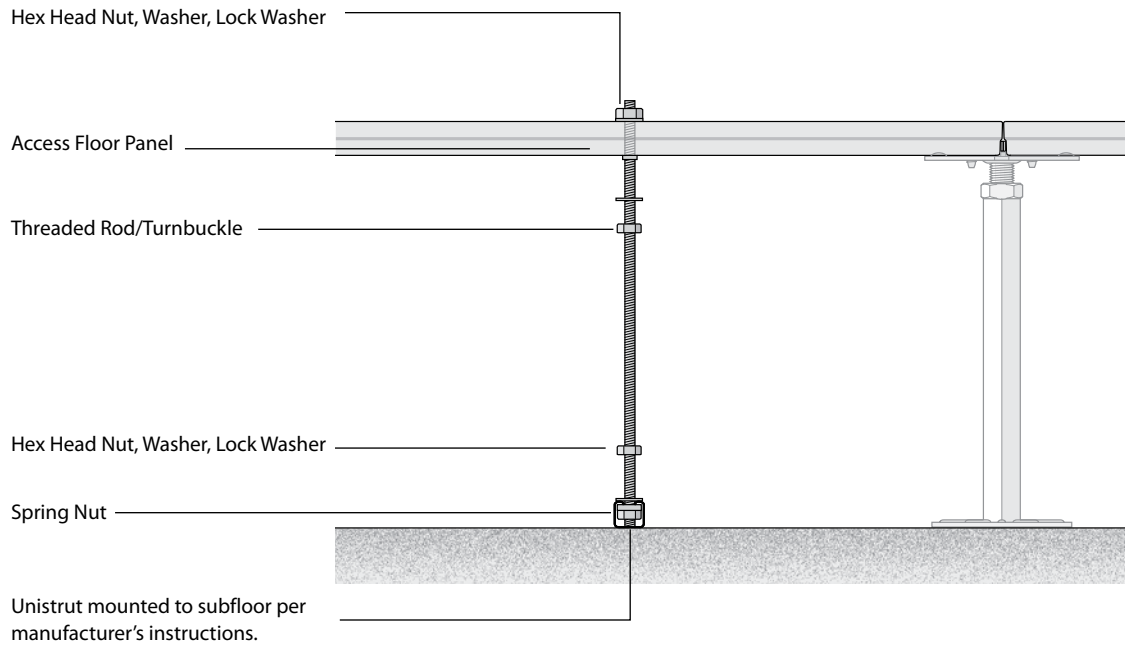

Mounting Equipment to Subfloors with Stringers

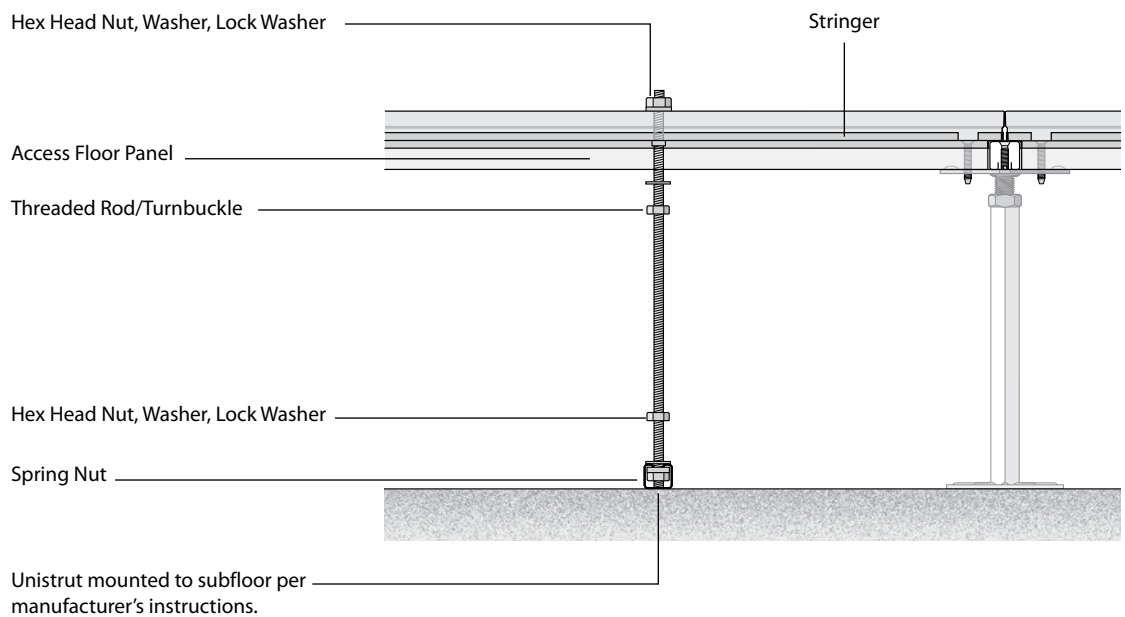

Mounting Equipment to TecCrete Access Floors

Supplemental Support for Heavy Equipment without Stringers

- Heavy load is any load that exceeds the concentrated load rating of the panel.

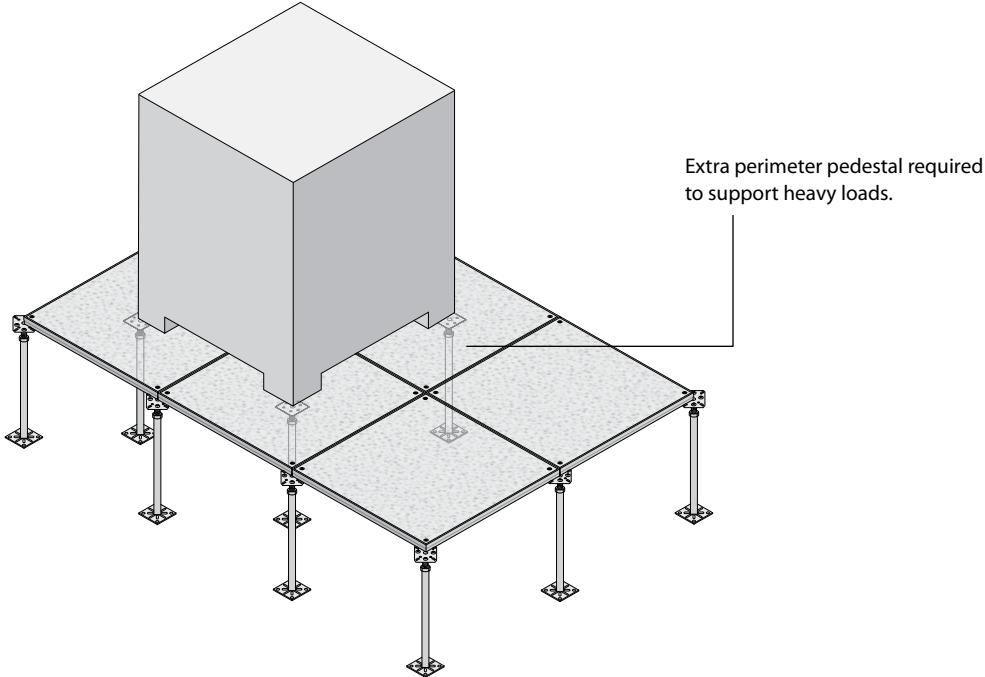

Supplemental Support for Heavy Equipment with Stringers

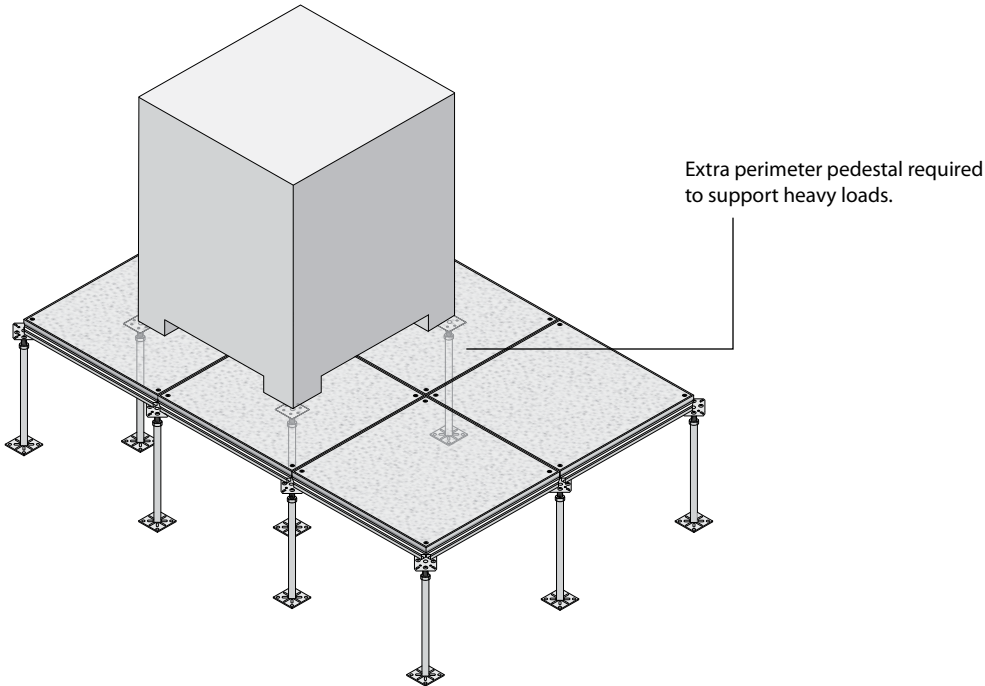

Fire and Safety Applications

Handrail Assemblies

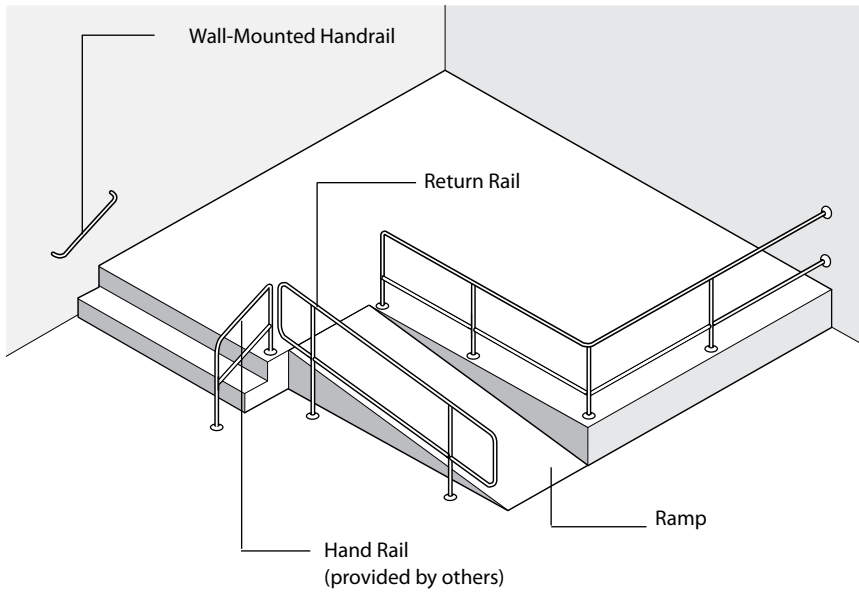

Fire Barrier at Door Threshold

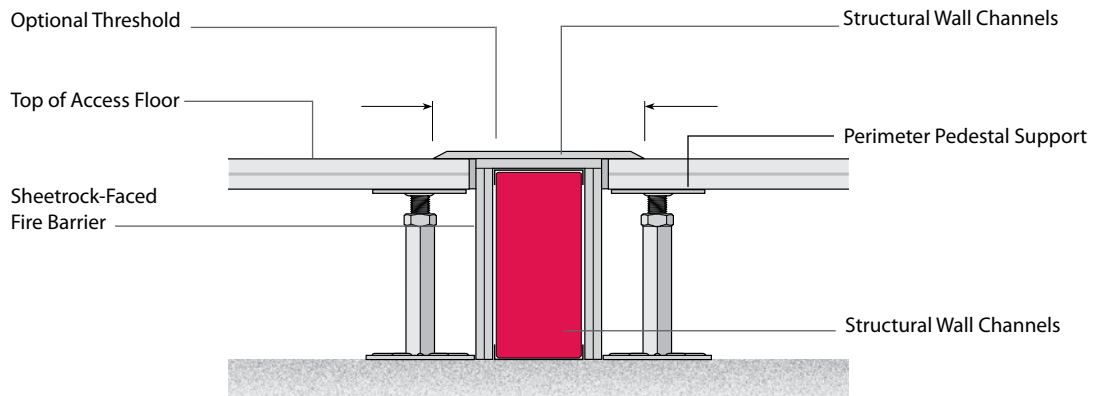
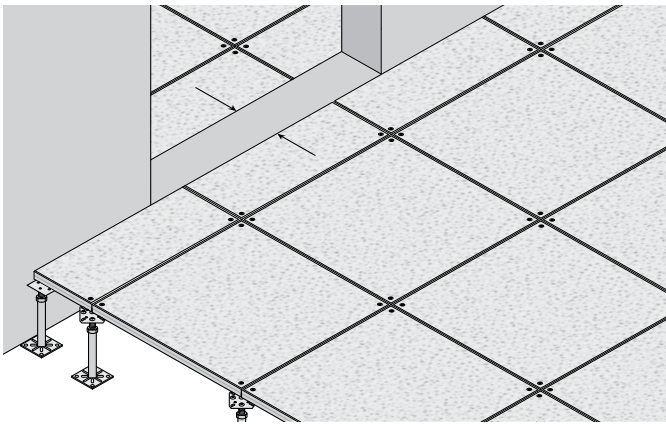

Fire and Safety Applications

Air Duct Through a Firewall

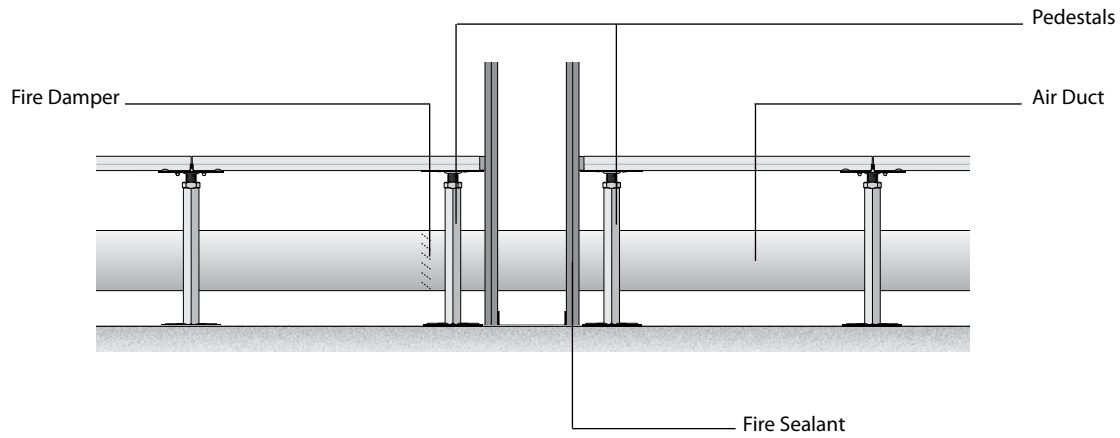

Thru-Slab Sprinkler Detail

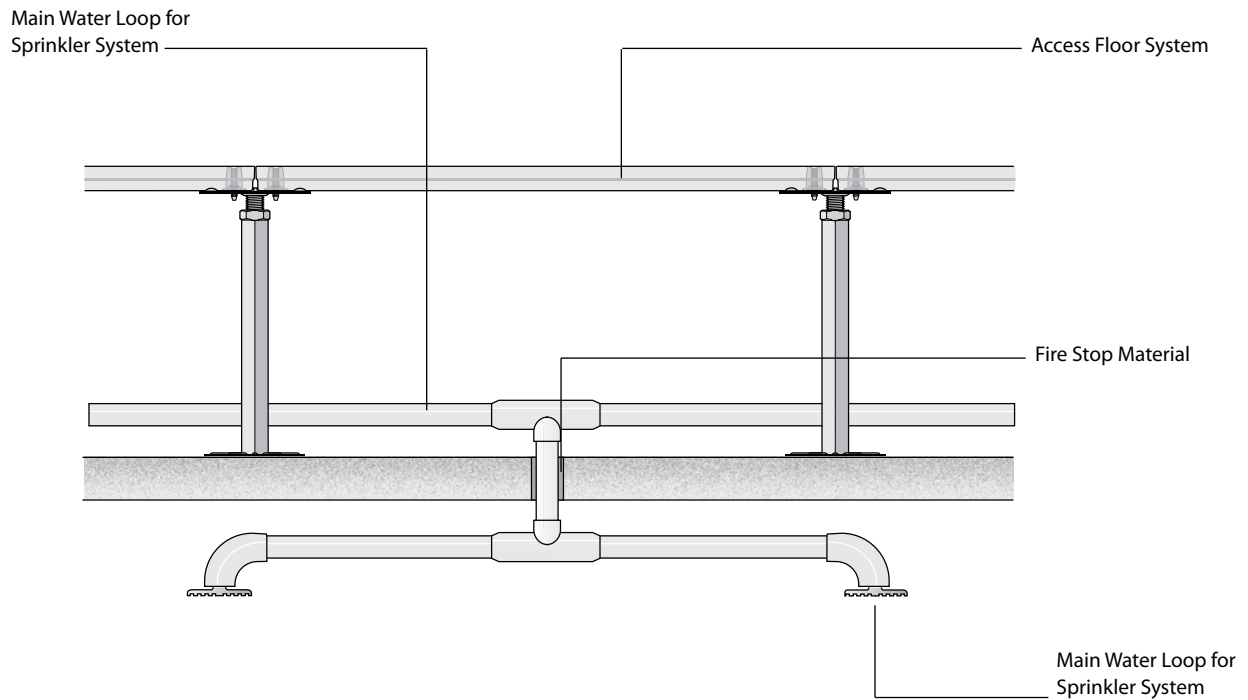

Note For plenum applications not utilizing carpet tile or stringers, an integral air seal may be specified on panels to optimize underfloor air system performance.

Bathroom Applications

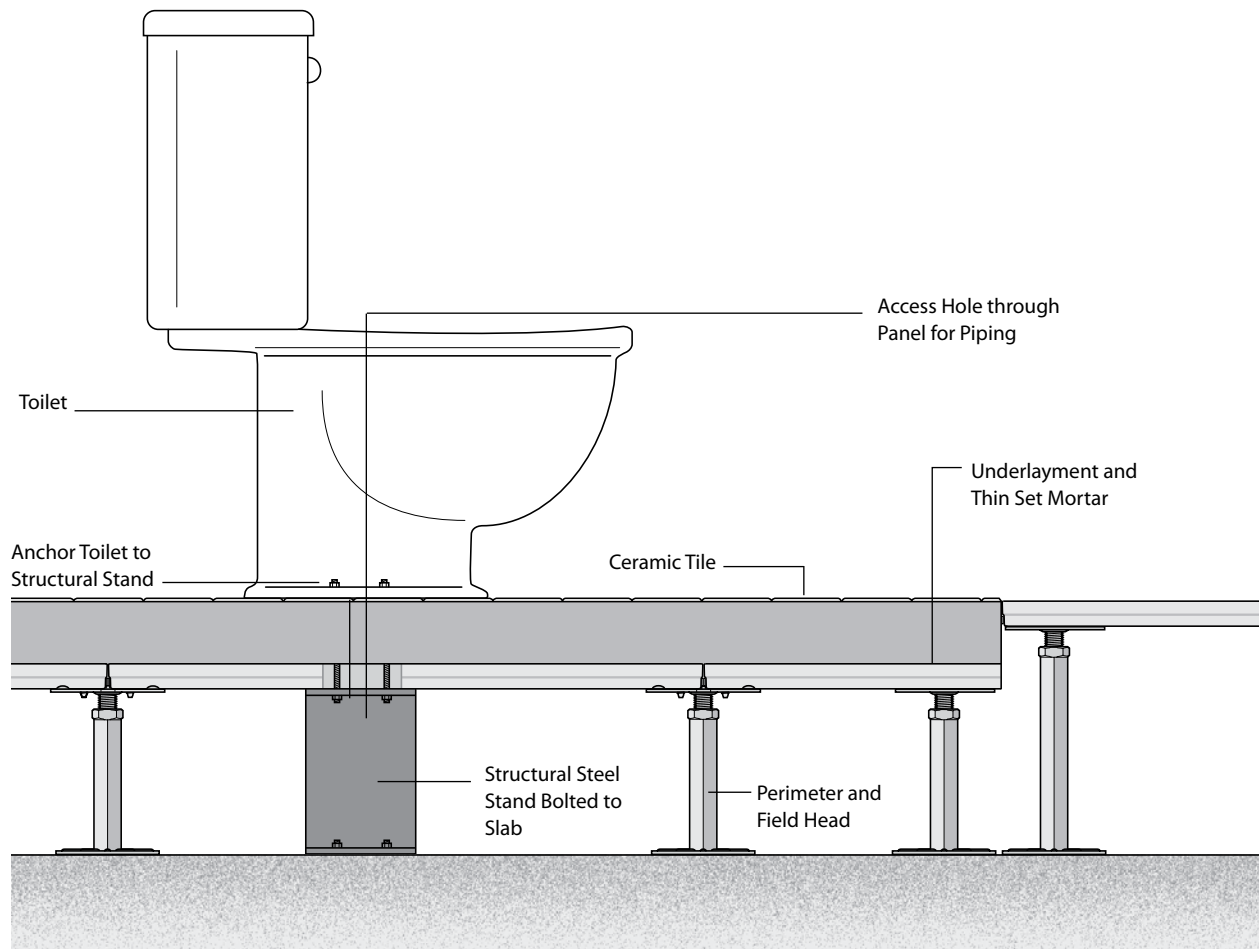

Electrical Applications

Electrical Box in Floor

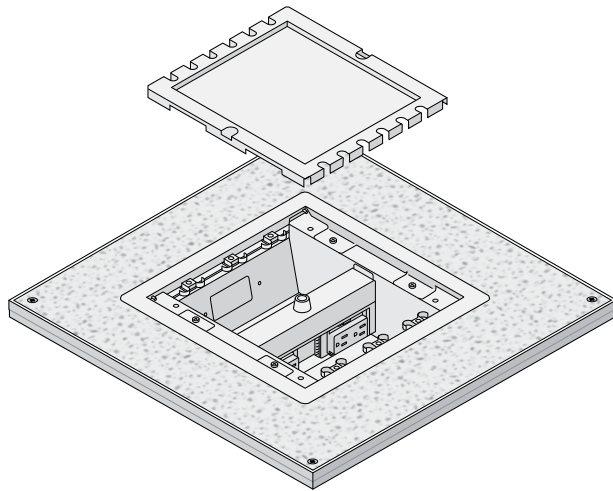

TecCrete Conductive Path to Ground without Stringers

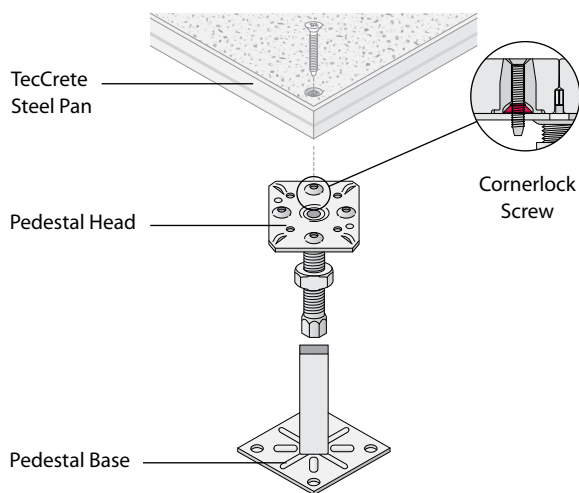

TecCrete Conductive Path to Ground with Stringers

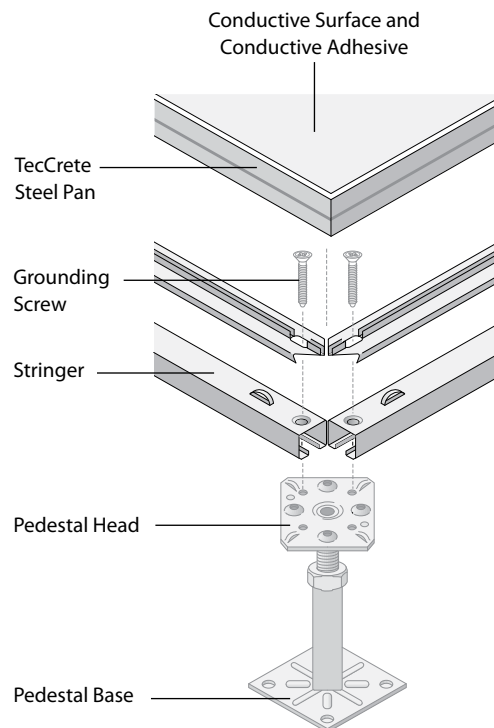

- Notes**
- Bare panel conductive path to ground: a cornerlock screw connects the steel pan to the pedestal head which is connected to the pedestal base — creating a ground path.
 - Covered panel conductive path to ground: conductive surface and conductive adhesive contact the TecCrete steel pan which contacts the grounding screw. The grounding screw is attached to the stringer which is also connected to the pedestal head and base — creating a ground path.

Controlling Air Leakage

TecCrete access flooring is often used to create an underfloor cavity for air distribution. When TecCrete is applied in this way, care must be taken to prevent unintentional air leakage from the underfloor cavity into the occupied space.

Unintentional air leakage occurs when pressurized air from an HVAC system enters the environment from sources other than the air diffusers. These sources can include gaps at access floor perimeters, columns, wall and slab openings, and around conduits, pipes and other obstructions. Although a properly installed access floor will minimize the possibility of unintentional air leakage, it is important to keep air control in mind during all phases of building construction and access floor installation. When each trade does its part to maintain the overall condition of subfloors, access floors, building cavities, and air passage points, the end result will be a well-sealed environment with minimal air leakage.

Air Tightness Specification

TecCrete access floor panels show exceptional air control properties. TecCrete specifications are twice as high as those of typical die-cut floor panels.

Air Distribution System Static Pressure	0.05"	0.10"
TecCrete floor panel with carpeted surface	No greater than 0.10 CFM / sq. ft	No greater than 0.10 CFM / sq. ft

Note Leak rates do not include leakage at floor perimeters.

TecCrete Air Tightness Performance

TecCrete panels, with and without installed carpet tiles, have shown exceptional air leakage control in laboratory tests.

Air Distribution System Static Pressure	0.05"	0.10"
TecCrete Panel Bare Floor with Air Seal Leak Rates	0.36 CFM / sq. ft.	0.44CFM / sq. ft.
TecCrete Panel with Solid-Backed Carpet Tiles – Leak Rates	0.04 CFM / lin. ft.	0.04 CFM / lin. ft.

Note The leak rates do not include leakage at floor perimeters; the carpet tiles overlapped the panel seams in the tests.

Controlling Air Leakage

Controlling Air Leakage During Construction and Access Floor Installation

There are many ways to effectively prevent unintentional air leakage in a TecCrete access floor installation. Your general contractor should make sure that every slab-to-ceiling wall fits tightly and is correctly sealed at the slab-line before access flooring is installed. Irregular wall surfaces may require gaskets, caulking, or tape to properly seal access floor-to-wall connections.

Building contractors must completely seal cavity seams where walls rest on subfloors, and where access flooring connects with slab-to-ceiling walls, columns and other obstructions.

It is also important that all utility access points — such as openings for air ducts, conduits, cables, and pipes — be carefully sealed. All openings in building elements for plumbing, electricity and voice/data cabling must be sealed by the trades that do those installations and should be inspected before access floors are installed. If additional openings are cut for utilities after the access floor is installed, those should be inspected for seal quality before carpet tiles are installed.

Your carpet installer also plays an important role in ensuring proper air sealing by fitting carpets snugly against walls and other vertical surfaces, and by consistently overlapping floor panel joints with carpet tiles. Extending carpet tiles all the way to the wall, carefully fitting perimeter panels, and tightly installing wall bases, all help to seal access floor perimeters.

Note For plenum applications not utilizing carpet tile or stringers, an integral air seal may be specified on panels to optimize underfloor air system performance.

Proper Air Sealing Before and During Access Floor Installation

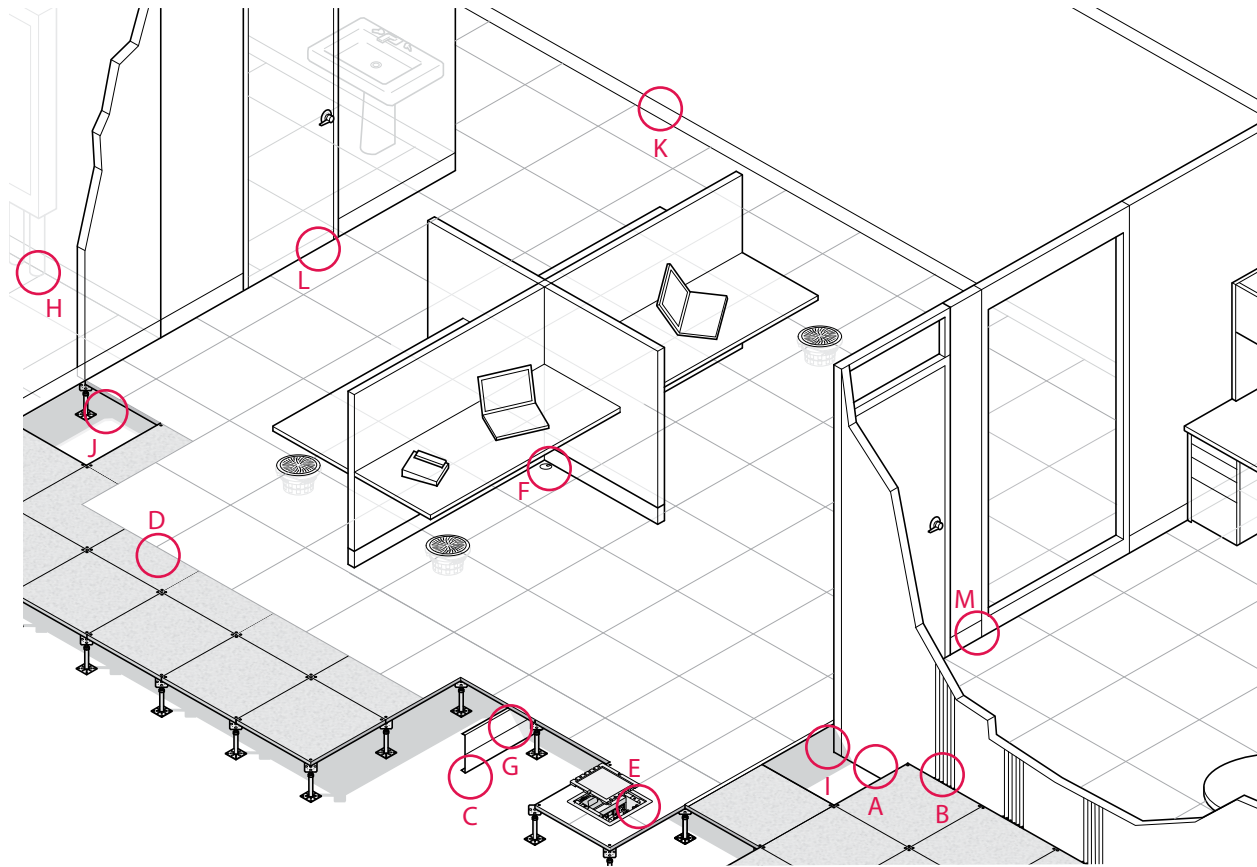

At Perimeters:

A Seals at flat perimeter walls and surfaces:

- All walls passing through the access floor must extend completely to the slab and be sealed at the slab line. Floor panels should fit to within $\frac{1}{16}$ " of perimeter walls, columns, and other vertical surfaces.
- If carpet tiles are used, they must also be cut to fit tightly against perimeter walls and surfaces as an additional layer of airseal protection.
- Wall bases should be installed tightly against carpet and access floor to cover joints.

B Seals at non-flat perimeter walls or other surfaces:

- Floor panels should fit to within $\frac{1}{16}$ " of perimeter walls.
- If the wall does not have a completely flat surface because it is shaped, textured, or slightly irregular, foam strips or rubber tape can be mounted flush with the floor surface to fill in gaps.
- The use of caulk or sealant to fill joints between floor panels and vertical surfaces is also an option. Using caulk or sealant instead of carpet adhesives will allow for easier removal of access floor panels later.
- If carpet tiles are used, they must also be cut to fit tightly against perimeter walls and surfaces as an additional layer of airseal protection.
- Wall bases should be installed tightly against carpet and access floor to cover joints.

C Seals at fascia or exposed edges:

- Fascia plates should be cut to align with the tops of floor panels.
- If there are any gaps between floor panel top edges and fascia, duct tape, or metal tape can be used to cover the joints before carpet installation.
- If carpet tiles are used, they must also be cut to fit all the way over fascia. Fascia and carpet tiles should be covered by angle trim pieces for airseal protection.

Proper Air Sealing Before and During Access Floor Installation

D Seals at curb interfaces:

- When access floor coverings extend all the way to the curb, cut the floor panels to within 1/16" of perimeter.
- Attach sealing foam or rubber tape to the curb if a gap exceeds 1/16" before floor panels are installed.
- Install carpet tiles by overlapping from access floor to curb.
- When access floor coverings do not extend all the way to the curb, cut the floor panels to within 1/16" of perimeter.
- Attach sealing foam or rubber tape to the curb if a gap exceeds 1/16" before floor panels are installed.
- Install carpet tiles by overlapping from access floor to curb.
- Seal the joint with a transition strip or threshold at top.

E Seals at utility access points

F Seals at cable cutouts:

- Cut foam to fit snugly into openings and support ledges.
- Install manufacturer's trim for cable cutouts.

G Seals at plenum dividers:

- Cut openings into the plenum divider that are sized for the dimensions of the ducts, pipes, conduit, and cable bundles that need to pass through.
- If there are any gaps, duct tape, or metal tape can be used to fill them before access floor installation.
- All gaps in building architecture should be sealed and inspected before the access floor is installed.

H Seals at pipe openings through access flooring:

- Cut openings into the access floor sized specifically for the diameters of the pipes that need to pass through.
- Seals at subfloor pipe openings.
- Seal gaps around pipes with caulk or sealant with firestop system materials before installing the access floor.

I Seals at fire barriers

J Seals at firewall utility access points:

- Wherever there is a gap between ducts, pipes, conduits or cable bundles, and the openings cut into firewalls to accommodate utility access, fill the gaps with approved firestop system materials.
- All gaps in building architecture should be sealed and inspected before the access floor is installed.

K Seals at firewalls at the access floor:

- Floor panels should fit to within 1/16" of perimeter walls, columns, and other vertical surfaces.
- If carpet tiles are used, they must also be cut to fit tightly against perimeter walls and surfaces as an additional layer of airseal protection.
- Wall bases should be installed tightly against carpet and access floor to cover joints.

L Seals at access floors at fire barrier below door threshold:

- Floor panels should be cut to fit to within 1/16" of the fire barrier.
- Joints can be sealed by installing a threshold plate with a gasket attached to the bottom.
- Another option for sealing joints is to attach a gasket to the vertical surface of the fire barrier and floor panels.
- A third option is to install floor panels and use a fire-rated caulk or sealant to fill any gaps between the panels and the fire barrier.
- If carpet tiles are used, they must also be cut to fit tightly against perimeter walls and surfaces as an additional layer of airseal protection.

M Seals at firewalls at the subfloor:

- Seal the firewall along the slab-line with fire-rated caulk or sealant that has rating equal to that of the wall assembly before installing access flooring.

Note Please refer to the TecCrete installation instructions for more detailed information.

Plenum Applications

Without Stringer

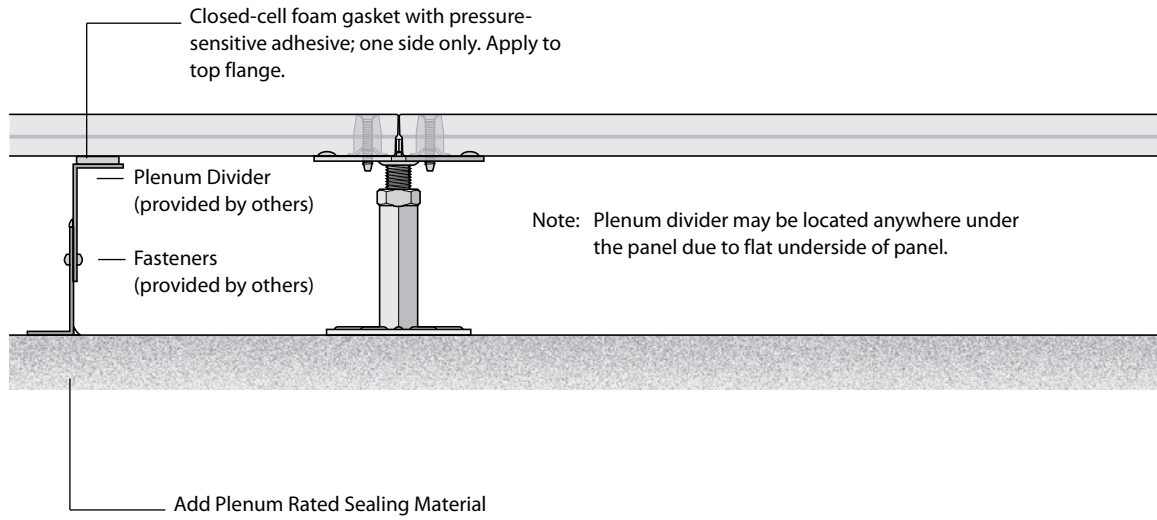

With Stringer

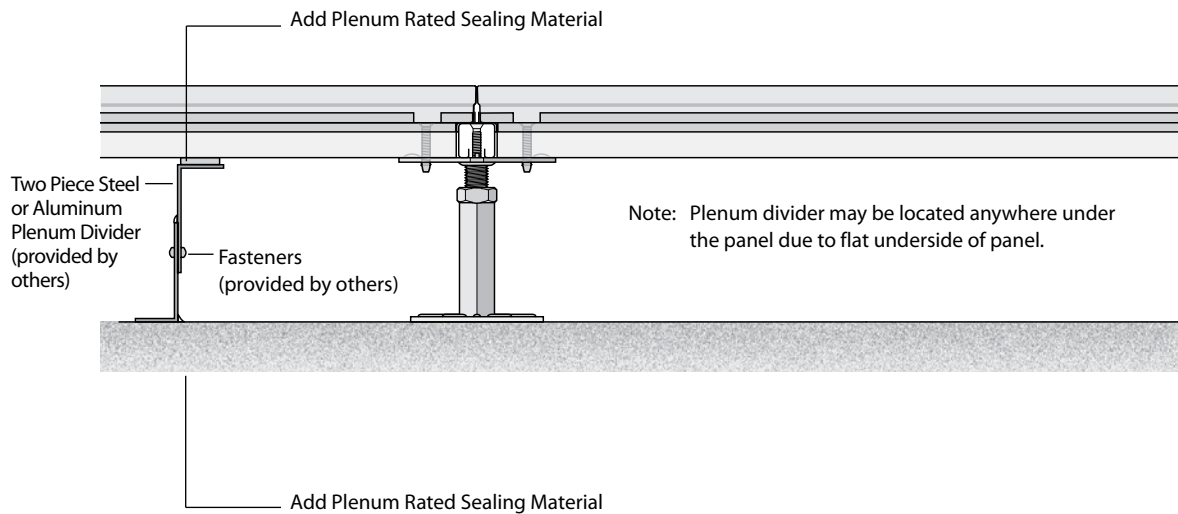

Plenum and Air Highway Applications

Plenum Divider/Plenum Divider Detail

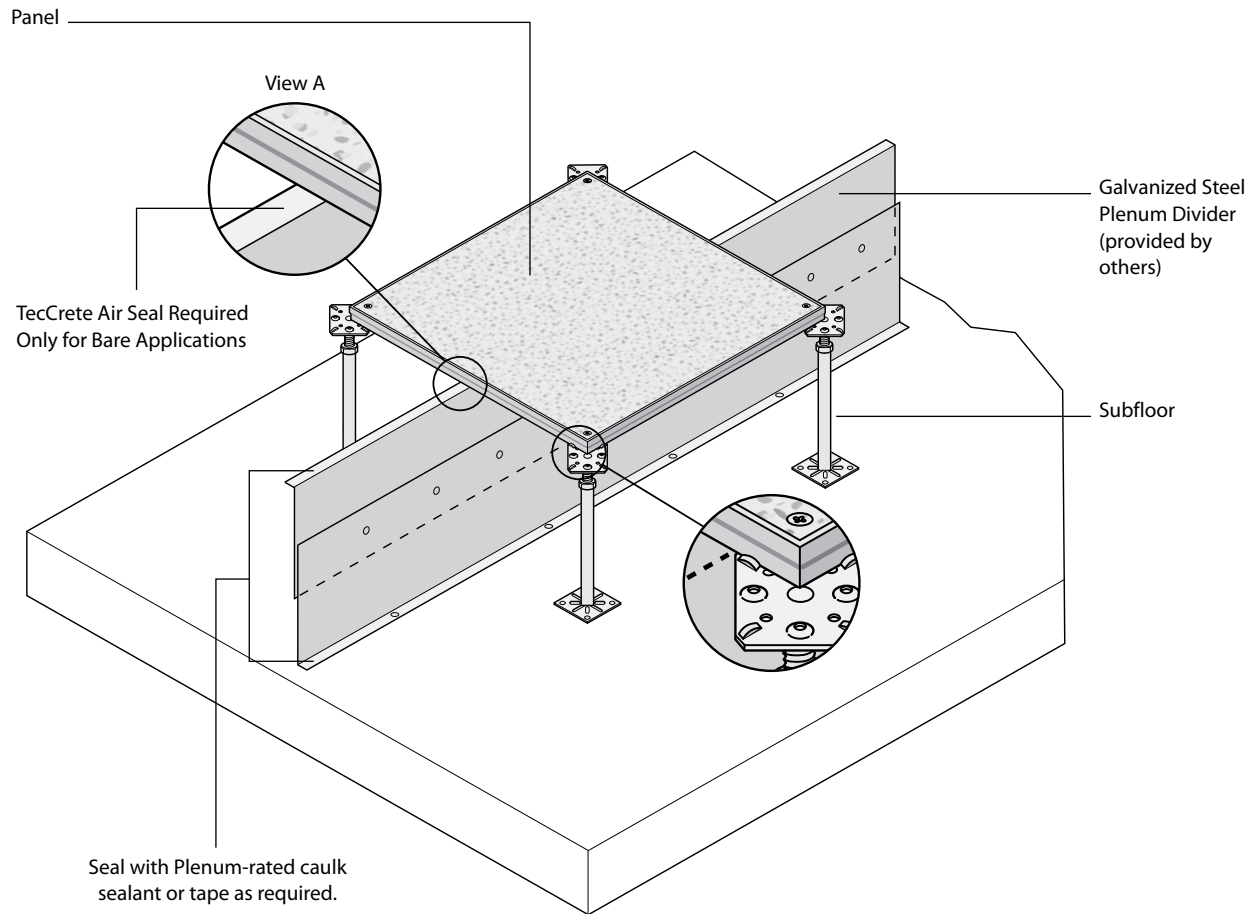

View A Detail: Side View

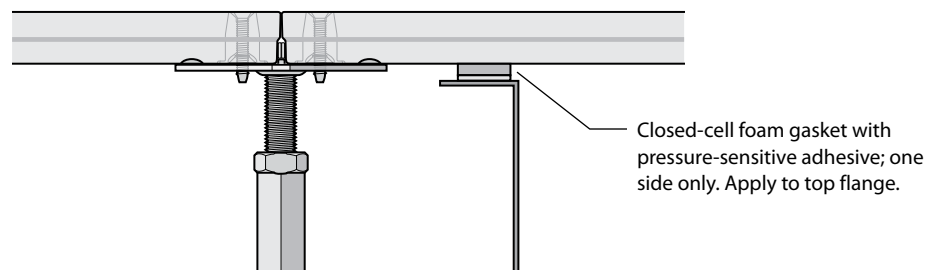

Plenum and Air Highway Applications

Air Highway: Interior

Air seal should be used in a bare panel installation. No air seal is required if the panel will be covered with another material.

Add plenum rated sealing material top and bottom.

Galvanized Steel Plenum Divider (provided by others)

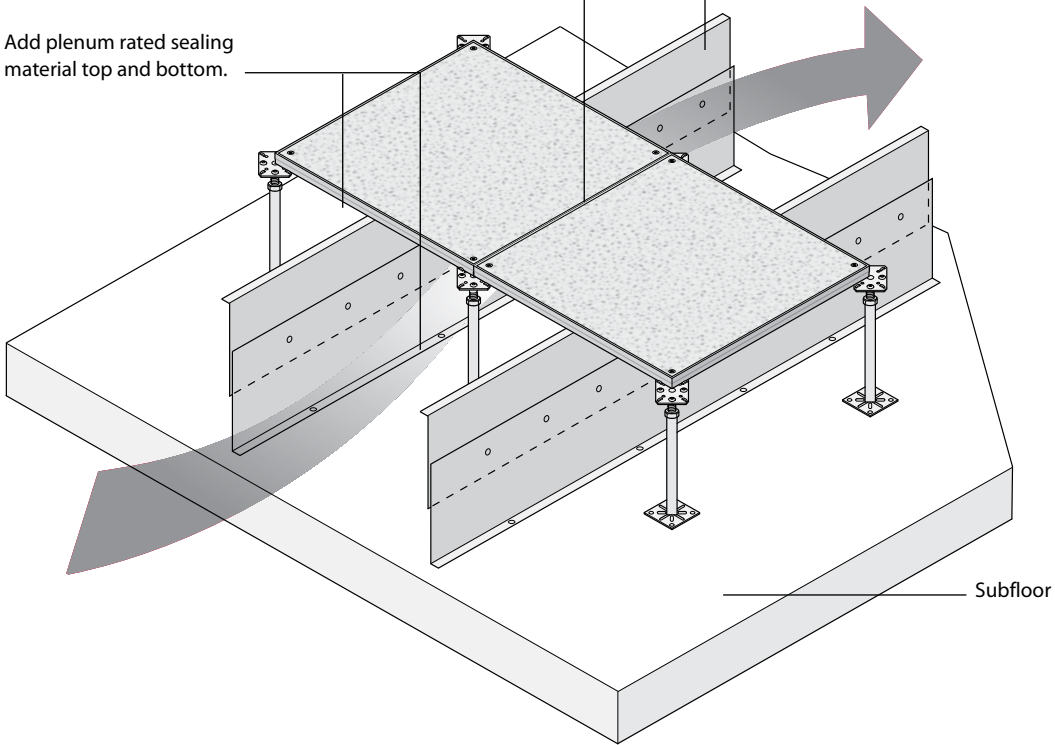

HVAC Duct

No air seal is required when ducting is used.

Panel

Subfloor

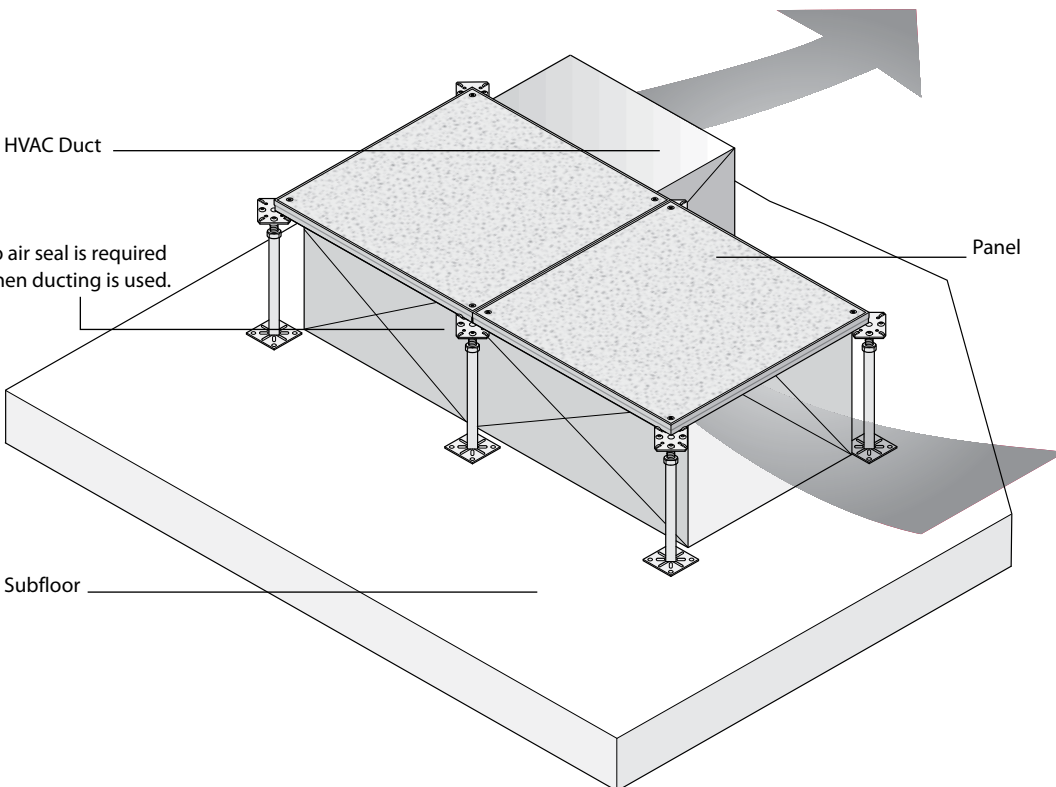

Plenum and Air Highway Applications

Air Highway and Divider Detail

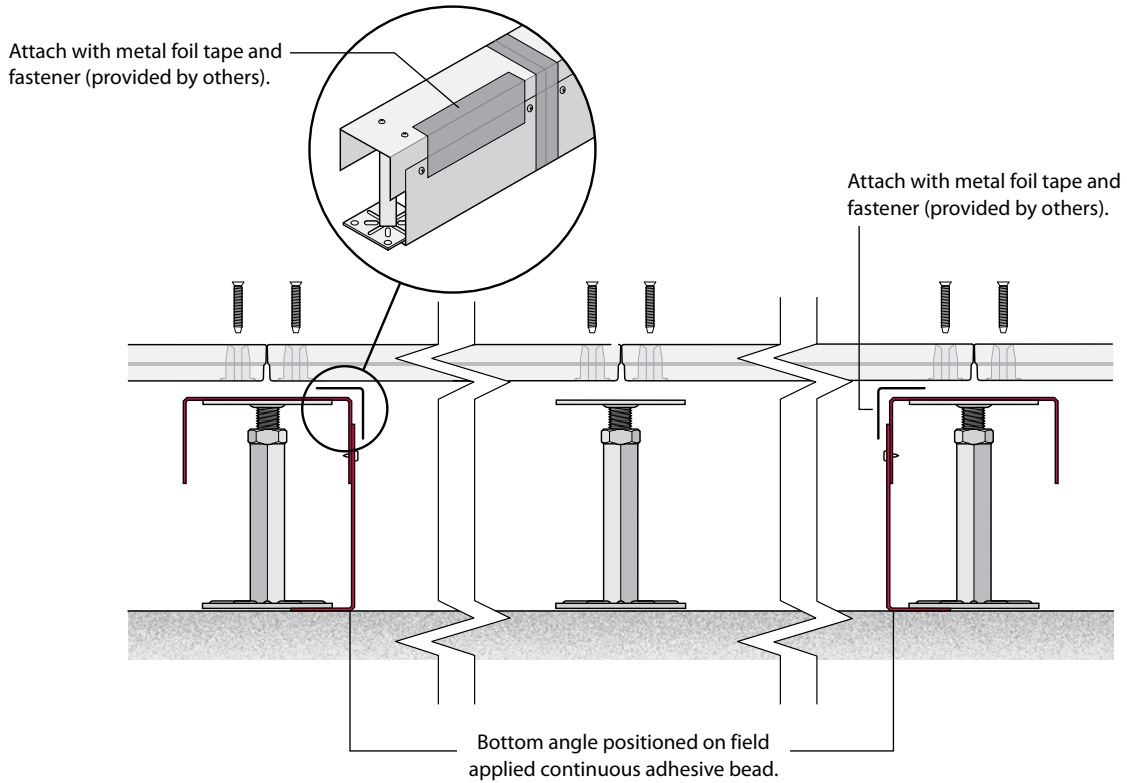

Air Highway with Utilities Pass-Through

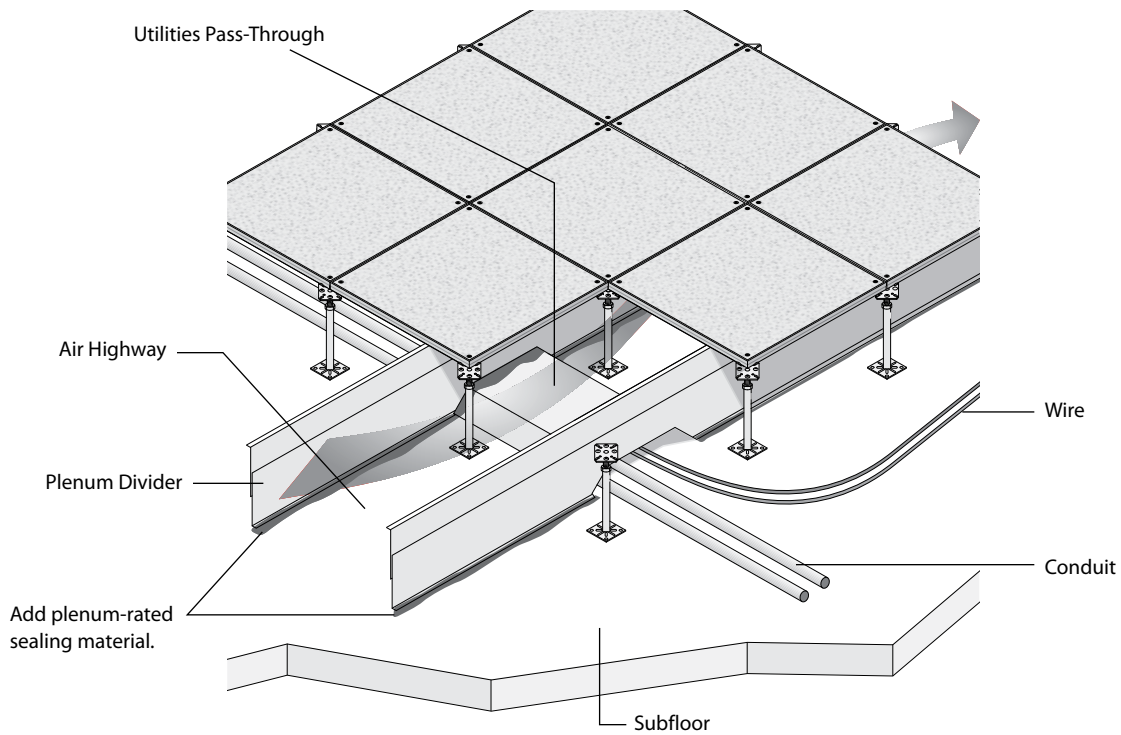

Plenum and Air Highway Applications

Plenum Zone Divider Detail

- TecCrete's flat panel underside delivers a gapless seal no matter where a plenum divider is positioned under the panel.

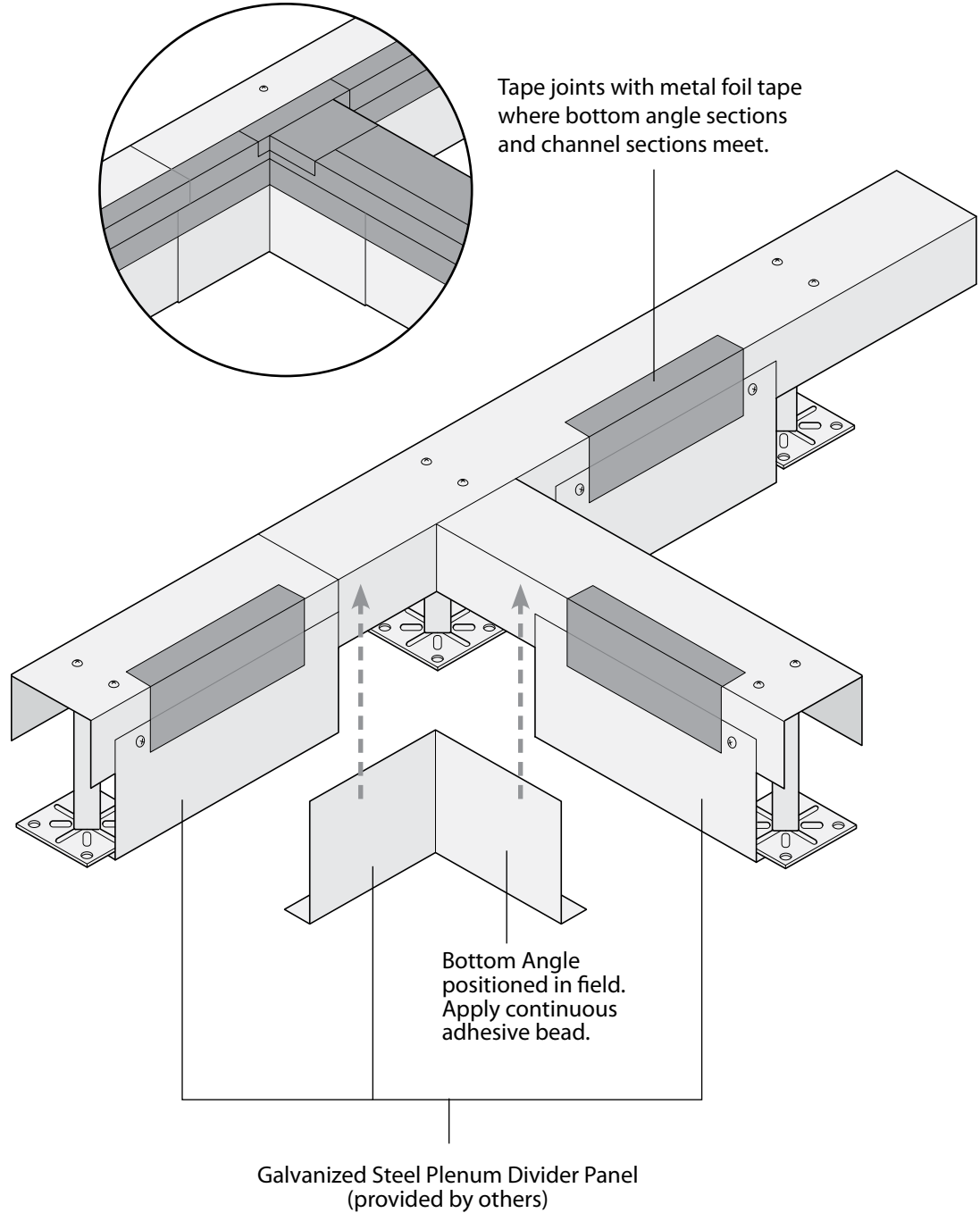

Plenum and Air Highway Applications

Penetration through Plenum Divider

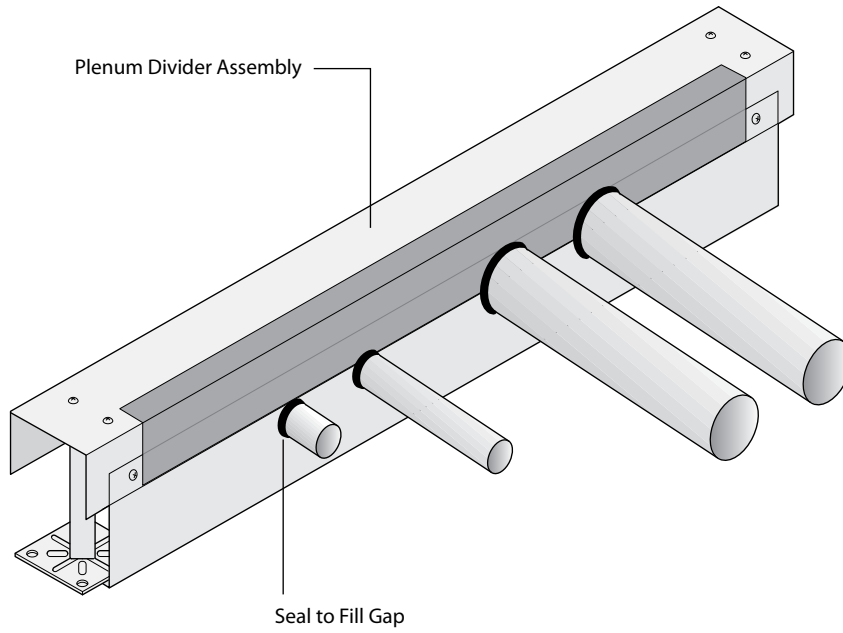

Air Seal Detail (optional)

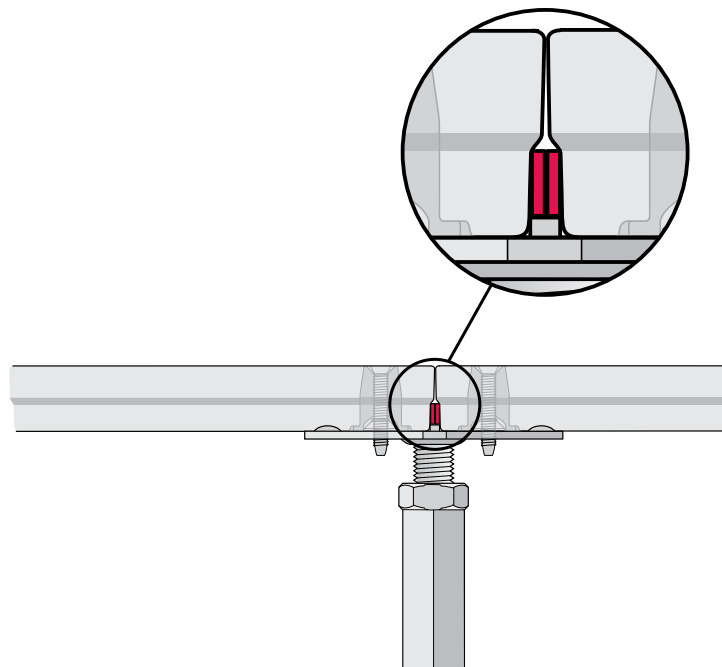

Note For plenum applications not utilizing carpet tile or stringers, an integral air seal may be specified on panels to optimize underfloor air system performance.

This page intentionally left blank.

Electrical Overview: Introduction

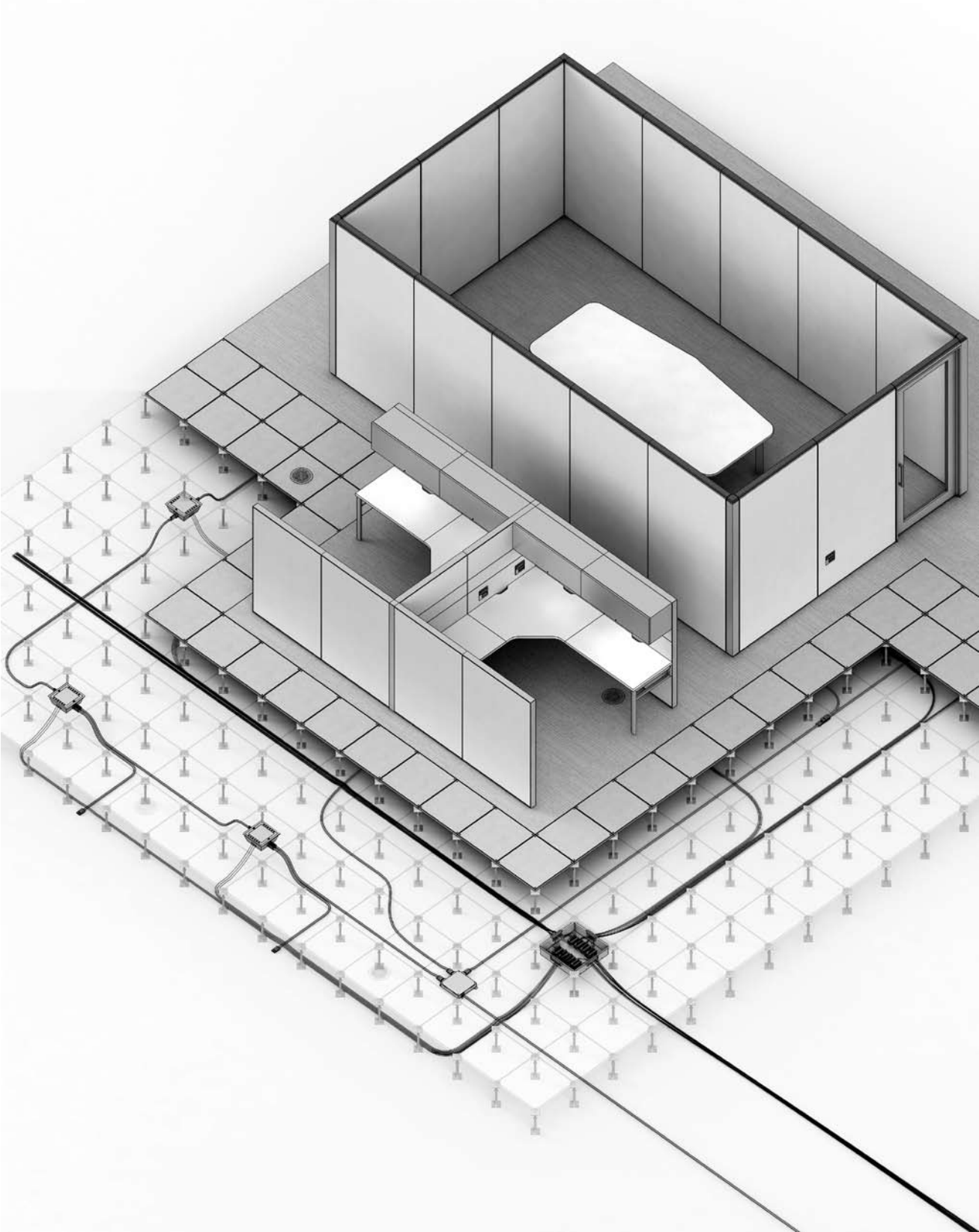

Our Philosophy On Electrical

Haworth has a unique approach when it comes to Electrical Distribution and its ever changing layout. Our philosophy is to design and install for tomorrow rather than conventionally wiring for today. How do we do that? By running everything right beneath your feet using plug-and-play technology and a zone distribution methodology that delivers power to where the customer needs it. This ensures that your electrical infrastructure will be able to respond to today's fast pace and fast rate of change. Being flexible today is critical to tomorrow's survival.

Reconfiguring should be fast, growing should be easy, and with Haworth Power Base AI, it is. Our quick-connect systems power you up ...fast!

Haworth offers Power Base AI, a modular power system for raised floor applications, which helps to ensure quick installation and future flexibility. Quick installation reduces construction schedule risk and controls jobsite labor overruns. Future flexibility helps increase tenant satisfaction and lowers operating and renovation costs.

Haworth has developed two power distribution systems to accommodate the electrical needs of all major North American office furniture manufacturers: The 3-Circuit and the 4-Circuit systems. Each has been specifically designed for use in Haworth Access Flooring and is based on plug-and-play connectivity.

The 3-Circuit separate neutral system provides individual branch circuits for power quality and multiple power source flexibility not available in 4-Circuit applications. The 4-Circuit shared neutral version helps to maximize the number of circuits while staying within the common 1/2" trade conduits. This modular power system is UL Listed, CSA Certified, and complies with NEC Article 604.

The Power Base AI system consists of six main elements to distribute power. They include the following:

- Zone Distribution Box
- Jumper
- Splitter
- Service Module
- Modular Receptacle
- Haworth Plug-and-Play Furniture Base Feed

Above Ceiling Application

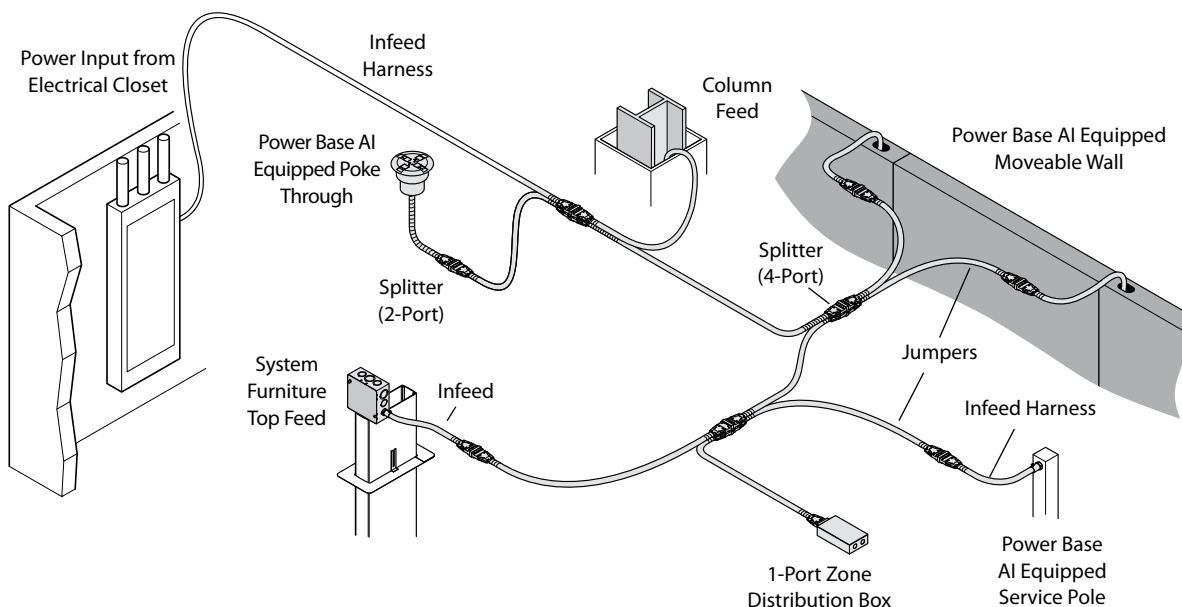

System Overview

Power is typically routed from the electrical closet through pre-wired flexible conduit to separate zones of the floor plate. Power is then distributed within each zone using modular wiring. Modular wiring puts flexibility out in the area where most day-to-day reconfigurations occur. Power can be routed from the electrical closet with the pre-wired Zone Distribution Box or an Infeed Harness. The Zone Distribution Box is available with factory installed pre-wired conduits with three sets up to 125', and two sets of circuits up to 200', or the field wired Zone Distribution Box can be used with locally supplied MC cable or conduit. The infeed harness routes a single set of circuits and is available in lengths up to 100'. Power is routed within the zone by 8-Wire modular flex conduit Jumpers. The Jumpers are fully populated with all eight wires so all circuits are available for future moves. The Flush Service Module provides Modular Receptacles under a hinged lid. The Modular Receptacles allow fast change of circuits as users' needs change. Flush Service Modules can be moved to other floor tile locations by re-routing the flex conduit Jumpers. The Service Modules allow for multiple Jumpers to connect (two Dual Service Modules/four Quad Service Modules) for branching within a zone. The Splitter is used to join up to four Jumpers. By using Splitters, the zone can be expanded to meet future needs. For more extensive renovations, the Zone Distribution Box can be moved by re-routing the flex conduit feed.

Under Floor Application

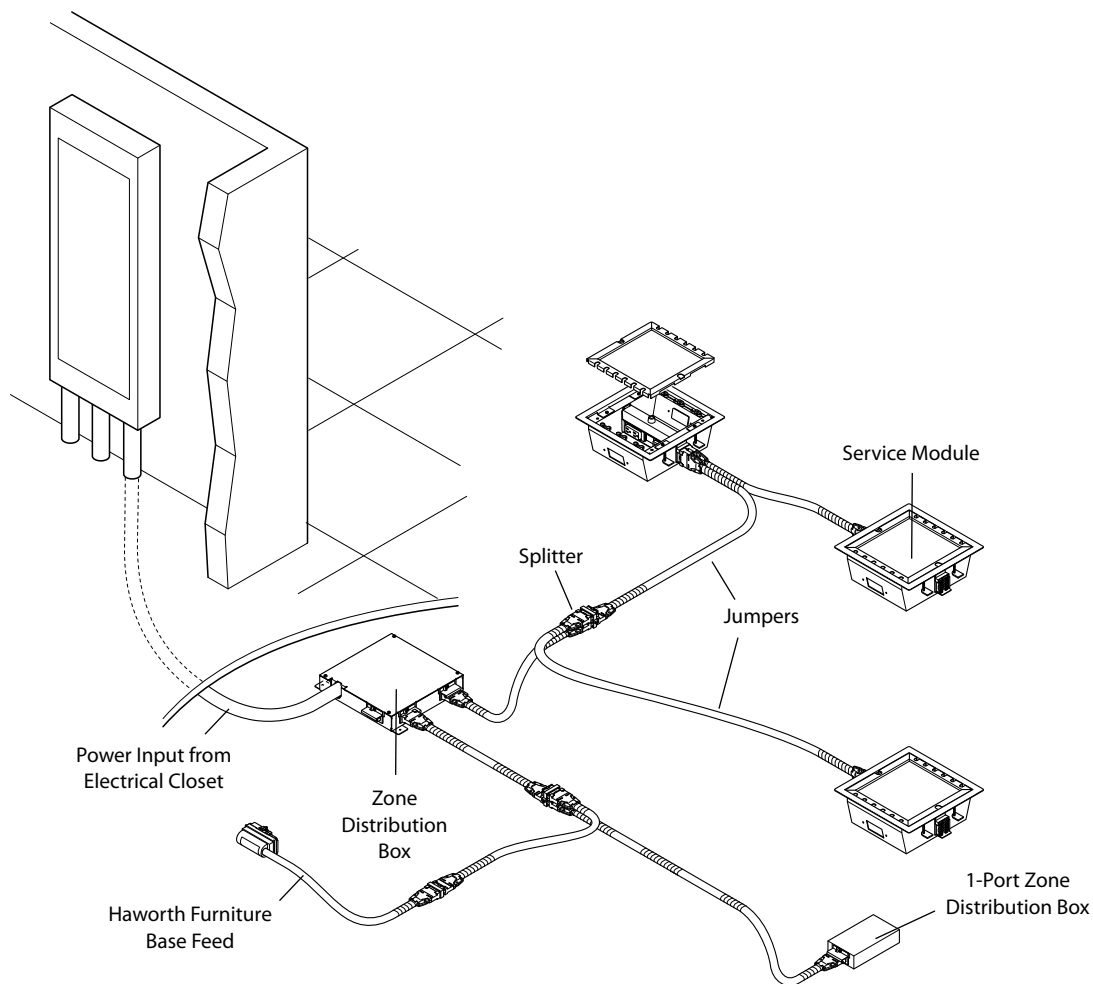

Note MC Cable = Metal Clad Cable in this document.

Statement of Line: Power Base AI

3- and 4-Circuit

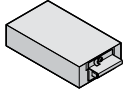

Field-Wired 1-Port
Zone Distribution Box

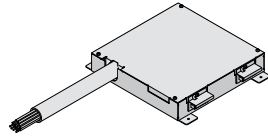

Pre-Wired 2-Port
Zone Distribution Box

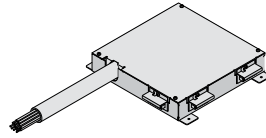

Pre-Wired 3-Port
Zone Distribution Box

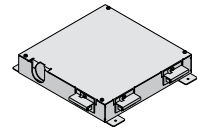

Field-Wired 3-Port
Zone Distribution Box

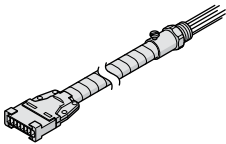

Infeed Harness
15', 10', 25', 50', 75', or 100' Long

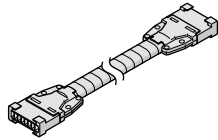

Jumper
5', 10', 15', 20', 35', or 50' Long

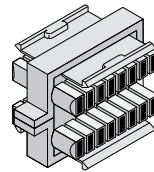

4-Port Splitter

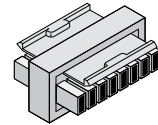

2-Port Splitter

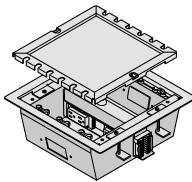

Quad Service Module

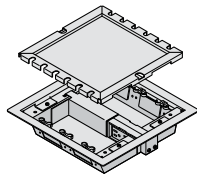

Dual Service Module

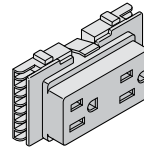

Modular Receptacle
(15 Amp Duplex)

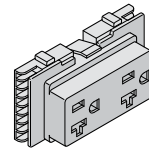

Modular Receptacle
(20 Amp Duplex)

Hardwire

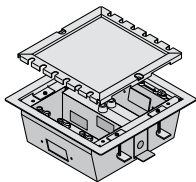

Quad Service Module
(Field-Wired)

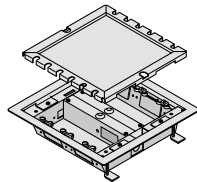

Dual Service Module
(Field-Wired)

Statement of Line: Power Base AI

Accessories

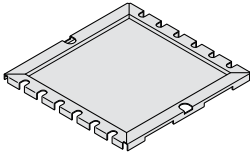

Service Module Lid

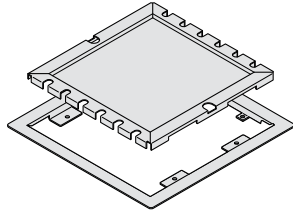

Service Module Lid and Trim Ring

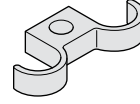

Cord Manager Loop

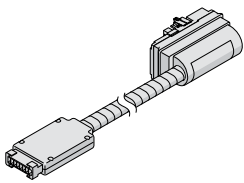

PREMISE®, Moxie®, and Compose™
Floor Infeed

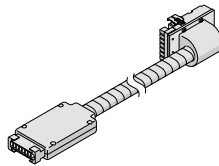

PLACES®, UniGroup®, and Tactics®
Floor Infeed

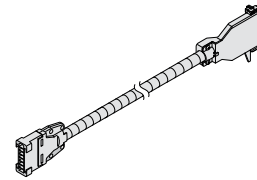

Floor Infeed

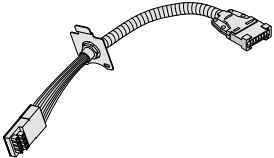

RACE® Single Harness Connector

Typical Power Base AI Application

Using Power Base AI with Enclose® or LifeSPACE® allows for maximum flexibility in reconfiguration of office space:

- To move an Enclose or LifeSPACE panel a short distance, simply move the panel to any new location within the jumper cable length.
- When reconfiguration requires a new layout, simply disconnect the jumper from the Enclose or LifeSPACE panel and Zone Distribution Box, move the Enclose or LifeSPACE panel to the new location, and reconnect the jumper to the Enclose or LifeSPACE panel and Zone Distribution Box.

- Notes**
- All ground fault circuit interrupter (GFI) outlets must be hard wired. If using LifeSPACE® electrical panels, the installation drawings for the wall panels and Power Base AI must be coordinated.
 - For more information, please see “Application Guidelines” on pages 23-25 of Haworth’s Power Base AI Application Guide.

This page intentionally left blank.

Pre-Terminated Zone Voice and Cabling

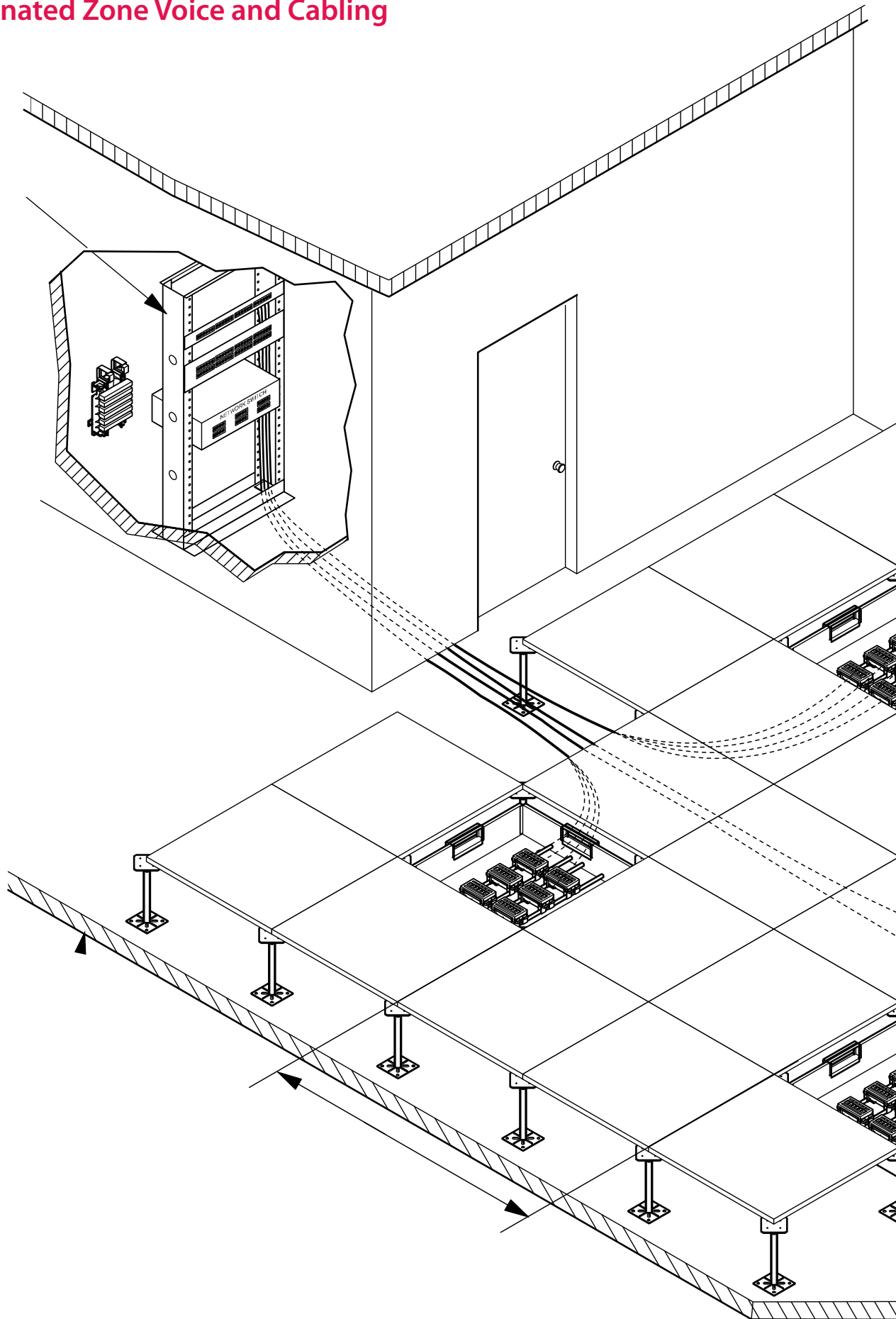

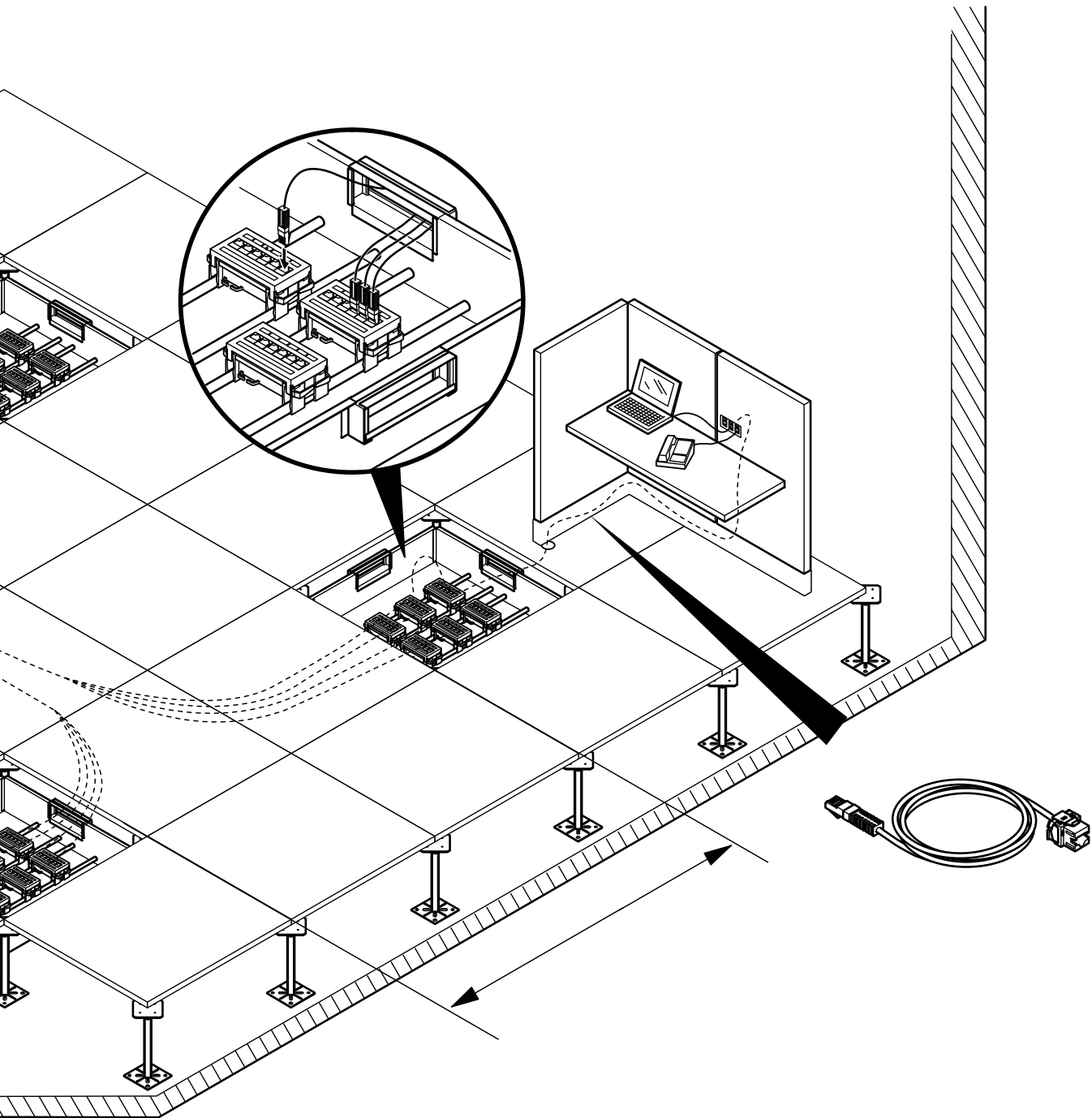

Statement of Line: Pre-Terminated Zone

Haworth offers Pre-Terminated Zone Voice and Data for access floor applications which help to ensure quick installation, future flexibility, reduced construction schedules, increased tenant satisfaction and lower operating and renovation costs.

Haworth's product solutions for voice and data include many familiar components in the following five categories:

1. Standard Components: 7' Equipment Racks, Patch Panels, and Ring Wire Managers

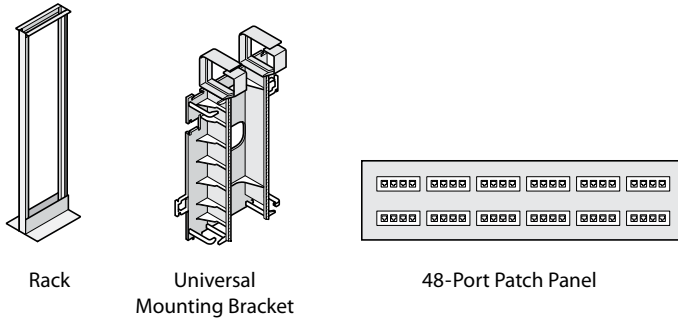

Rack

Universal
Mounting Bracket

48-Port Patch Panel

2. Standard Horizontal Cabling: Communication Cabling and Consolidation Points

Communication cabling (Cat 5e or Cat 6) that is routed through the ceiling or floor to a consolidation point (UMS Patch Panels, Ultim8, etc.). It is available in non-plenum and plenum rated jacket.

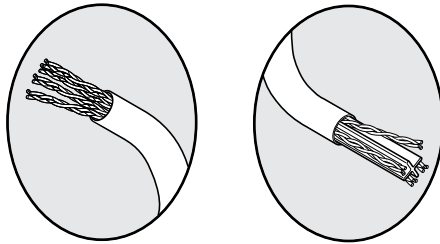

3. Pre-Terminated Zone Consolidation Points

Available products include 12-port zone consolidation box, UMS patch panels, 24- and 48-port patch panels, and external consolidation point housings. In addition, a plenum box is available for air handling applications. Each type of consolidation point device acts as a modular connection point for outlet taps.

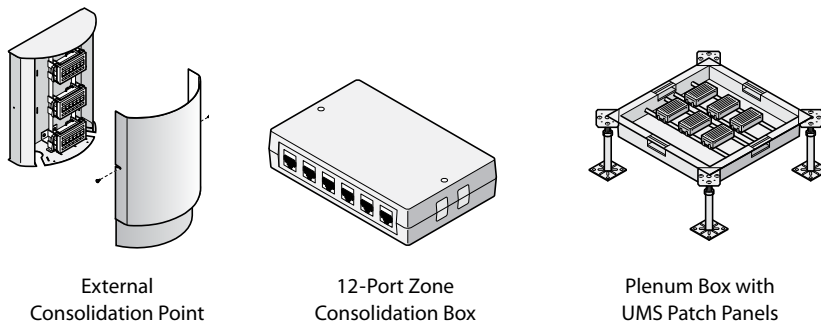

External
Consolidation Point

12-Port Zone
Consolidation Box

Plenum Box with
UMS Patch Panels

Statement of Line: Pre-Terminated Zone

4. Outlet Taps

Outlet taps include an outlet jack on one end (RJ45) and a modular plug on the other. Plenum-rated versions are available. In addition, the outlet tap can be unterminated.

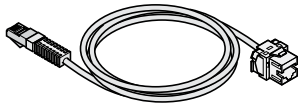

Outlet Tap with Jack



Outlet Tap Unterminated

5. Faceplates and Patch Cords

Modular furniture and single-gang faceplates are available, along with TrueNet patch cords in 4', 7', 10', and 15' lengths.

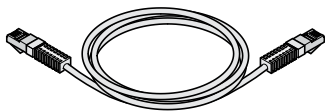

Patch Cord

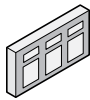

3-Port Modular Faceplate

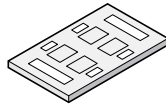

4-Port Flush Modular Faceplate

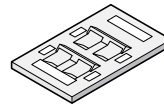

4-Port Angled Faceplate

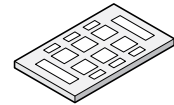

6-Port Flush Mount Faceplate

Note For additional information, please refer to Haworth's Voice and Data Price List.

Introduction

TecCrete® Contributions Toward Meeting LEED®-NC 3

TecCrete Access Flooring can play an important role in projects that are seeking certification under the LEED for New Construction rating system.

Key considerations include:

Air Quality. The materials in TecCrete products do not adversely impact indoor air quality. Also, the concrete top surface of TecCrete can be sealed with low-or-no VOC sealers.

Design for Environment (DfE). TecCrete is a very durable product that is 100% reusable. Designing product that maximizes the years of useful life is one of many strategies related to Design for Environment (DfE).

Recycled Content. TecCrete product contains recycled content materials. Steel pedestals are 25-30% recycled content and steel pans are 80% recycled content.

Because LEED is a holistic building rating system and sustainable design guideline, there is no such thing as a LEED-certified product; there are only ways of using and applying products to meet LEED criteria. In some cases, TecCrete product contributes directly to individual LEED points, but in other cases can only help contribute to the overall intent of the point. There are relatively few instances where selection of any one product from any manufacturer will lead directly to acquisition of a point(s) under LEED.

The information provided below discusses direct impacts as well as application tips and strategies to maximize the contribution of TecCrete products toward their project’s LEED certification.

Credit Description	Direct Impact	Indirect Impact
EA Prerequisite 2 – Minimum Energy Performance		•
EA Credit 1 – Optimize Energy Performance		•
MR Credit 1.2 – Building Reuse, Maintain Interior Non-Structural Elements	•*	
MR Credit 2 – Construction Waste Management		•*
MR Credit 3 – Materials Reuse	•*	
MR Credit 4 – Recycled Content	•	
MR Credit 5 – Regional Materials	•	
IEQ Prerequisite 1 – Minimum IAQ Performance		•
IEQ Credit 2 – Increased Ventilation	•	
IEQ Credit 3.1 – Construction IAQ Management Plan		•
IEQ Credit 4.1 – Low Emitting Materials (Adhesives and Sealants)		•
IEQ Credit 4.3 – Low Emitting Materials (Flooring Systems)		•
IEQ Credit 6.2 – Controllability of Systems (Thermal Comfort)	•	
IEQ Credit 7.1 – Thermal Comfort	•	
IEQ Credit 8.1, 8.2 – Daylight and Views	•	

*For TecCrete product that is part of the existing building

- Notes**
- LEED® -NC rating system is continually updated, please refer to www.usgbc.org for the most current versions.
 - Intent and Requirement information is paraphrased from the U.S. Green Building Council publication “LEED Reference Guide for Green Building Design and Construction V3”. For exact wording consult the U.S.G.B.C website at www.usgbc.org.

Energy and Atmosphere

EA Prerequisite 2: Minimum Energy Performance

Intent

- Establish the minimum level of energy efficiency for the proposed building and systems.

How TecCrete Helps Meet This Requirement

- TecCrete Access Flooring enables underfloor air distribution, which has been shown to reduce the energy costs required for cooling interior spaces by 5%-30%, thus helping to reduce the overall design energy cost of the building.

EA Credit 1: Optimize Energy Performance (1-10 pts)

Intent

- Achieve increasing levels of energy performance above the prerequisite standard to reduce environmental impacts associated with excessive energy use.

How TecCrete Helps Meet This Requirement

- TecCrete Access Flooring enables underfloor air distribution, which has been shown to reduce the energy costs required for cooling interior spaces by 5% – 30%, thus helping to reduce the overall design energy cost of the building.

Note Intent and Requirement information is paraphrased from the U.S. Green Building Council publication “LEED Reference Guide for Green Building Design and Construction V3”. For exact wording consult the U.S.G.B.C website at www.usgbc.org.

Materials and Resources

MR Credit 1.2: Building Reuse (1-2 pts)

- Maintain 75% (100%) of Interior, Non-Structural Elements

Intent

- Extend the life cycle of existing building stock, conserve resources, retain cultural resources, reduce waste, and reduce environmental impacts of new buildings as they relate to materials manufacturing and transport.

How TecCrete Helps Meet This Requirement

- Contribution to this credit is dependent on TecCrete being part of the prior structure. However, adding TecCrete and modular power and data systems will create value for buildings that pursue LEED for future major updates.
- Raised floors are typically left intact, with all changes to walls occurring between the raised floor and the ceiling.
- TecCrete is 100% reusable. It is designed for easy disassembly and movement from one space to another. The ability to reuse building materials significantly reduces budgets for new spaces, with an equivalent decrease in resource demands.
- Underfloor air distribution systems are inherently reusable. Tiles with diffusers need only be relocated, and not discarded and replaced in order to accommodate changes in mechanical loads. In addition, underfloor air distribution reduces the need for ductwork (up to 80% less ductwork than conventional HVAC), so changes to the cooling system do not generate additional waste.
- Flooring finishes used with Haworth raised floors, such as carpet, are also modular tile systems, which can be removed and re-laid in new configurations and locations.
- Though not recognized yet by LEED for the initial installation, raised floors minimize life cycle costs and address future material conservation and reuse. This will create value for buildings which pursue LEED for future major updates.

MR Credit 2: Construction Waste Management (Divert from Disposal 50% [1pt] / 75% [2pts])

Intent

- Divert construction and demolition debris from disposal in landfills and incineration facilities. Redirect recyclable recovered resources back to the manufacturing process and reusable materials to appropriate sites.

How TecCrete Helps Meet This Requirement

- TecCrete does not directly impact this point. However, waste reduction through intelligent design can decrease the amount of construction waste generated in installation and prevent additional waste generation during changes to the space or when moving to a new space.
- Modular power and data systems used with access flooring allow the installation of technology infrastructure with near zero waste. This eliminates conduit, electrical wiring, and data wiring waste.
- Raised floor systems generate very little construction waste, with only a few tiles that need to be trimmed to size or need to have penetrations installed on-site that generate scrap. Even this waste can be minimized with careful planning.
- TecCrete is also 100% reusable, eliminating waste on future reconfigurations.

Note Intent and Requirement information is paraphrased from the U.S. Green Building Council publication “LEED Reference Guide for Green Building Design and Construction V3”. For exact wording consult the U.S.G.B.C website at www.usgbc.org.

Materials and Resources

MR Credit 3: Materials Reuse (1-2 pts)

Intent

- Reuse building materials and products to reduce demand for virgin materials and reduce waste, thereby lessening impacts associated with the extraction and processing of virgin resources.

How TecCrete Helps Meet This Requirement

- Contribution to this credit is dependent on these products being part of the prior structure. However, adding TecCrete and modular power and data systems will create value for buildings which pursue LEED for future major updates.
- TecCrete is 100% reusable. It is designed for easy disassembly and movement from one space to another.
- The ability to reuse building materials significantly reduces budgets for new spaces, with an equivalent decrease in resource demands.
- Underfloor air distribution systems are inherently reusable. Tiles with diffusers need only be relocated, and not discarded and replaced in order to accommodate changes in mechanical loads. In addition, underfloor air distribution reduces the need for ductwork (up to 80% less ductwork than conventional HVAC), so changes to the cooling system do not generate additional waste.
- Modular power and data systems used with access flooring are also 100% reusable. It is designed for easy disassembly and movement from one space to another. This replaces conduit, electrical wiring, and data wiring that is not recoverable or reusable.

MR Credit 4: Recycled Content (1-2 pts)

Intent

- Increase demand for building products that incorporate recycled content materials, thereby reducing impacts resulting from extraction and processing of virgin materials.

TecCrete Recycled Content

Material	Material Weight	Post-Consumer Recycled Content	Pre-Consumer Recycled Content
Steel	7.51 lbs. (16%)	4.25 lbs	2.46 lbs.
Gypsum	35.10 lbs. (78%)	0.00 lbs	19.92 lbs.
Portland Cement			
Aggregate			
Water	3.02 lbs. (6 %)	0.00 lbs.	0.00 lbs.
Total	45.63 lbs. (100%)	4.25 lbs. (9.3%)	22.40 lbs. (49.1%)
Total Recycled Content: (4.25 lbs. + 22.40 lbs.) / 45.63 lbs. = 58.4%			

How TecCrete Helps Meet This Requirement

- TecCrete has recycled content values as listed:
 - 58.4% Total Recycled Content % by weight
 - 9.3% Post-Consumer Content % by weight
 - 49.1% Post-Industrial Content % by weight
 - 33.9% LEED RC (PC+½PI) % by value

Note Intent and Requirement information is paraphrased from the U.S. Green Building Council publication “LEED Reference Guide for Green Building Design and Construction V3”. For exact wording consult the U.S.G.B.C website at www.usgbc.org.

Materials and Resources

MR Credit 5: Regional Materials (1 pt)

Intent

- Increase demand for building materials and products that are extracted and manufactured within the region, thereby supporting the use of indigenous resources and reducing the environmental impacts resulting from transportation.

How TecCrete Helps Meet This Requirement

- TecCrete products are produced in Kentwood, Michigan. TecCrete is manufactured within a 500-mile radius of approximately 50% of the population of the United States. Contribution to this credit depends on the location of the project.

Raw Material Components of TecCrete (including understructure)

Raw Material	Extraction Source
Gypsum	Ft. Dodge, Iowa
Aggregate	Brooklyn, Indiana
Portland Cement	Alpena, Michigan
Coil and Other Steel	Butler, Indiana
Other Materials	Michigan

Indoor Environmental Quality

IEQ Prerequisite 1: Minimum IAQ Performance

Intent

- Establish minimum indoor air quality (IAQ) performance to enhance indoor air quality in buildings, thus contributing to the comfort and well-being of the occupants.

How TecCrete Helps Meet This Requirement

- Underfloor air distribution systems (UFAD) are inherently likely to meet or exceed the requirements of ASHRAE 62.1-2007 because their much higher ventilation effectiveness makes delivery of high quality air into the occupied zone easier.
- Underfloor air distribution also operates at much lower air velocities, which reduces the risk of airborne contaminants.
- TecCrete raised floor product can accommodate UFAD systems and help meet this prerequisite.

IEQ Credit 2: Increased Ventilation (1 pt)

Intent

- Provide additional outdoor air ventilation to improve indoor air quality (IAQ) and promote occupant comfort, well being, and productivity.

How TecCrete Helps Meet This Requirement

- Underfloor air distribution is a preferred strategy to meet the requirements of this credit. Raised floor systems combined with underfloor air distribution and user controlled swirl diffusers typically have air change effectiveness of 0.9 or greater. This is significantly easier to achieve with underfloor air systems than it is with overhead air distribution (air change effectiveness typically <0.7) because air is discharged directly into and all mixing of air occurs within the occupied zone.
- TecCrete raised floor product can accommodate UFAD systems and help meet this credit.

IEQ Credit 3.1: Construction IAQ Management Plan (During Construction): (1 pt)

Intent

- Prevent indoor air quality problems resulting from construction or renovation and promote the comfort and well-being of construction workers and building occupants.

How TecCrete Helps Meet This Requirement

- Underfloor air distribution systems (UFAD) installed along with access floor solutions eliminate 80% of the overhead ductwork and produce much less construction waste and dust than conventional overhead HVAC systems.
- TecCrete access floor product can accommodate UFAD systems and help meet this credit.

IEQ Credit 4.1: Low Emitting Materials (Adhesives and Sealants) (1 pt)

Intent

- Reduce the quantity of indoor air contaminants that are odorous, irritating, and/or harmful to the comfort and well-being of installers and occupants.

How TecCrete Helps Meet This Requirement

- Haworth sells adhesives that meet the requirements of this credit.
- Haworth keeps a list of sealants that work with the TecCrete system meeting the requirements of this credit.

Indoor Environmental Quality

IEQ Credit 4.3: Low Emitting Materials (Flooring Systems) (1 pt)

Intent:

- To reduce the quantity of indoor air contaminants that are odorous, irritating and/or harmful to the comfort and well-being of installers and occupants.

How TecCrete Helps Meet This Requirement

- TecCrete floor system has been SCS Indoor Advantage Gold certified, assuring that it meets tough indoor air quality standards including the requirements of South Coast Air Quality Management District (SCAQMD) Rule 1113, Architectural Coatings, effective January 1, 2004.

IEQ Credit 6.2 Controllability of Systems: Thermal Comfort (1 pt)

Intent

- Provide a high level of thermal comfort system control by individual occupants or groups in multi-occupant spaces (i.e. classrooms or conference areas) to promote their productivity, comfort and well-being.

How TecCrete Helps Meet This Requirement

- Underfloor air distribution systems (UFAD) using swirl diffusers provide every occupant and/or group within a building the ability to control the airflow and temperature within their space.
- TecCrete raised floor product can accommodate UFAD systems and swirl diffusers to help meet this credit.

IEQ Credit 7.1 Thermal Comfort: Compliance with ASHRAE 55-1992 (1 pt)

Intent

- Provide a comfortable thermal environment that promotes occupant productivity and well-being.

How TecCrete Helps Meet This Requirement

- Buildings with access floors that utilize underfloor air distribution (UFAD) have an inherent advantage in meeting and exceeding ASHRAE Standard 55-2004. Discharge temperatures are much closer to normal ambient temperatures, minimizing the presence of hot and cold spots in the environment.
- Systems operate at lower pressures and lower air velocities than overhead systems, eliminating drafts and excess heating/cooling for occupants who sit immediately adjacent to HVAC diffusers.
- TecCrete access floor product can accommodate UFAD systems to meet this credit.

IEQ Credit 8.1 Daylight and 8.2 Views (Daylight 75% and Views 90% of Spaces): (1-2 pts)

Intent

- Provide for the building occupants a connection between indoor spaces and the outdoors through the introduction of daylight and views into the regularly occupied areas of the building.

How TecCrete Helps Meet This Requirement

- TecCrete Access Flooring used in conjunction with underfloor air distribution can reduce the amount of overhead ductwork (up to 80% reduction in ductwork over conventional HVAC) and increase the overall height of the wall space available for exterior glazing.

Note Intent and Requirement information is paraphrased from the U.S. Green Building Council publication "LEED Reference Guide for Green Building Design and Construction V3". For exact wording consult the U.S.G.B.C website at www.usgbc.org.

TecCrete System Performance Ratings

Haworth Access Floors are tested according to "Recommended Procedures for Access Flooring" as established by the Ceiling and Interior Systems Construction Association (CISCA).

TecCrete 1250 System Performance Ratings

Rolling Load

- 1,200 lbs. applied through a 3" (76mm) dia. x 1³/₁₆" (46mm) wide caster for 10 cycles over the same path with a maximum of 0.040" (1 mm) top surface permanent set.
- 800 lb. applied through a hard rubber-surfaced wheel 6" (152mm) dia. x 2" (51mm) wide for 10,000 cycles over the same path with a maximum of 0.040" (1mm) top surface permanent set.

Impact Load Rating

150 lb. load dropped from 36" (914mm) onto a one-inch square indenter shall not render the system unserviceable.

Concentrated Load Rating

1,250 lb. load on one square inch (25mm) at any location with a top surface deflection not to exceed 0.10" (3mm), and a permanent set not to exceed 0.010" (0.25mm).

Uniform Load Rating

With a top surface deflection not exceeding 0.040" (1mm), TecCrete can hold 600 pounds per square foot evenly distributed over the surface of the panel with a permanent set not exceeding 0.010" (0.25mm).

Ultimate Load

- 1,800 lb. per square inch minimum at weakest point.

TecCrete 1500 System Performance Ratings

Rolling Load

- 1,500 lbs. applied through a 3" (76mm) dia. x 1³/₁₆" (46mm) wide caster for 10 cycles over the same path with a maximum of 0.040" (1mm) top surface permanent set.
- 1,250 lb. applied through a hard rubber-surfaced wheel 6" (152mm) dia. x 2" (51mm) wide for 10,000 cycles over the same path with a maximum of 0.040" (1mm) top surface permanent set.

Impact Load Rating

150 lb. load dropped from 36" (914mm) onto a one-inch square indenter shall not render the system unserviceable.

Concentrated Load Rating

1,500 lb. load on one square inch (25mm) at any location with a top surface deflection not to exceed 0.10" (3mm), and a permanent set not to exceed 0.010" (0.25mm).

Uniform Load Rating

With a top surface deflection not exceeding 0.040" (1mm), TecCrete can hold 700 pounds per square foot evenly distributed over the surface of the panel with a permanent set not exceeding 0.010" (0.25mm).

Ultimate Load

- 2,500 lb. per square inch minimum at weakest point.

TecCrete System Performance Ratings

TecCrete 2000/2500 System Performance Ratings

Rolling Load

- 2,000 lbs. applied through a 3" (76mm) dia. x 1 $\frac{3}{8}$ " (46mm) wide caster for 10 cycles over the same path with a maximum of 0.040" (1mm) top surface permanent set with edge supported stringers.
- 1,750 lb. applied through a hard rubber-surfaced wheel 10" (254mm) dia. x 4" (102mm) wide for 10,000 cycles over the same path with a maximum of 0.040" (1mm) top surface permanent set with edge support stringers.

Impact Load

A 150 lb. load dropped from 36" (914mm) onto a one-inch square indenter shall not render the system unserviceable.

Concentrated Load Rating

Allows for maximum 2,500 lbs. at 0.10" deflection and 0.015" permanent set.

Uniform Load

With a top surface deflection not exceeding 0.040" (1mm), TecCrete can hold 1100 pounds per square foot evenly distributed over the surface of the panel with a permanent set not exceeding 0.010" (0.25mm).

Ultimate Load

- 3,100 lb. per square inch minimum at weakest point with edge support stringers.

This page intentionally left blank.

This page intentionally left blank.

TecCrete Access Flooring: Office

Three Part Guide Specification

PART 1 - GENERAL

An editable Microsoft® Word version of this document is available for download at www.haworth.com.

1.01 Description

- A. The access floor system shall consist of interchangeable panels, understructure, and all labor, material, equipment, and installation as called for in the specifications and/or shown on the Architect's Drawings.
- B. Access floor manufacturer shall be ISO9001:2000 certified demonstrating it has a robust and well documented quality management system with continual improvement goals and strategies.
- C. Access floor manufacturer's facilities shall be ISO14001:2004 certified demonstrating that they maintain an environmental management system.
- D. Access floor product must be indoor air quality certified to conform to CA Section 01350 Specification for classroom and standard office.
- E. Access floor product shall be manufactured in a zero landfill facility.
- F. Related Work Specified Elsewhere:
 - 1. Concrete work and concrete floor sealer is specified in Section 03 30 00.
 - a) Concrete sealer and pedestal adhesive must be chemically compatible with each other.
 - 2. Carpet and carpet tile work as specified in Section 09 68 00 (09680 MasterFormat 95).
 - 3. Mechanical air distribution as specified in Section 23 30 00 (15800 MasterFormat 95).
 - 4. Electrical connections and grounding as specified in Section 26 05 00 (16100 MasterFormat 95).
- G. Access Floor Air Plenum Requirements
 - 1. The access floor contractor is aware that the space beneath the access floor will be used as an air delivery plenum and as such will take the necessary precautions when installing their work so as not to impact the integrity of the plenum space specific to air leakage and cleanliness.
 - 2. Panel construction shall have a flat steel bottom to create a fully sealed plenum.
 - 3. When panels are to be used bare without carpet or other floor coverings an optional air sealing gasket may be used to prevent air leakage.

1.02 Environmental Conditions for Storage and Installation

- A. The General Contractor must provide a dry accessible area to receive and unload material with a free path to elevators, hoists, and/or the area receiving the access floor.
- B. Prior to and during installation, a secure and dry storage space closed to the weather must be made available for the access floor materials, with recommended environment at 40° F to 120° F and approximately 35% to 70% relative humidity, 24 hours a day during and after installation.
- C. The subfloor surface must be free of moisture, dust, dirt and other debris. Once installed, the access floor must be maintained in the same manner.

PART 1 - GENERAL

1.03 Design Performance and Certification of Product

- A. Provide access flooring system consisting of moveable assemblies composed of modular floor panels supported on pedestals with stringers forming accessible underfloor cavities to accommodate electrical, mechanical, and HVAC services and complying with performance requirements specified. Raised floor panels must be interchangeable with each other except where cut for special conditions.
- B. Where applicable load testing shall be performed according to "Recommended Test Procedures for Access Flooring" as established by the Ceiling and Interior Systems Construction Association (CISCA). These procedures shall be used as a guideline when presenting load performance product information.

The following applies to TecCrete 1250 Raised Access Flooring only:

1. Concentrated Load: 1,250 lb. on one square inch (25mm) at any location with a top surface deflection not to exceed 0.10" (2.5mm), and a permanent set not to exceed 0.010" (0.25mm).
2. Uniform Load: With a top surface deflection not exceeding 0.040" (1mm), TecCrete can hold 600 pounds per square foot evenly distributed over the surface of the panel with a permanent set not exceeding 0.010" (0.25mm).
3. Ultimate Load: 1,800 lb. per square inch minimum at weakest point.
4. Rolling Load: Panels shall withstand a rolling load of 1,200 lbs. applied through a 3" (76mm) dia. x 1¹³/₁₆" (46mm) wide caster for 10 cycles over the same path with a maximum of 0.040" (1mm) top surface permanent set. Panels shall withstand a rolling load of 800 lb. applied through a hard rubber-surfaced wheel 6" (152mm) dia. x 2" (51mm) wide for 10,000 cycles over the same path with a maximum of 0.040" (1mm) top surface permanent set.
5. Impact Load: A 150 lb. load dropped from 36" (914mm) onto a one-inch square indenter shall not render the system unserviceable.
6. Flammability: Bare panel system shall meet Class A requirements for Flame spread and smoke development when tested in accordance with ASTM-E84 and a maximum Flame spread of 25, Smoke development of 50 based on the average of three runs when tested in accordance with CAN/ULC S102.
7. Combustibility: All components of the access floor system shall qualify as noncombustible by demonstrating compliance with requirements of ASTM E 136, Standard Test Method for Behavior of Materials in a Vertical Tube Furnace at 750° C.
8. Recycled Content: Panel and understructure system shall be required to have a minimum recycled content of 50%.

The following applies to TecCrete 1500 Raised Access Flooring only:

1. Concentrated Load: 1,500 lb on one square inch (25mm) load at any location with a top surface deflection not to exceed 0.10" (2.5mm) and a permanent set not to exceed 0.010" (0.25mm).
2. Uniform Load: With a top surface deflection not exceeding 0.040" (1mm), TecCrete can hold 700 pounds per square foot evenly distributed over the surface of the panel with a permanent set not exceeding 0.010" (0.25mm).
3. Ultimate Load: Panel shall be designed to withstand load of 2,500 lb. minimum at weakest point with stringer.

PART 1 - GENERAL

4. Rolling Load: Panels shall withstand a rolling load of 1,500 lbs. applied through a 3" dia. (76mm) x 1³/₁₆" (46mm) wide caster for 10 cycles over the same path with less than 0.040" top surface permanent set. Panels shall withstand a rolling load of 1,250 lb. applied through a hard rubber-surfaced wheel 6" (152mm) dia. x 2" (51mm) wide for 10,000 cycles over the same path. Permanent set at the conclusion of the test shall not exceed 0.040" (1mm).
5. Impact Load: A 150 lb. load dropped from 36" (914mm) onto a one-inch square indenter shall not render the system unserviceable.
6. Flammability: Bare panel system shall meet Class A requirements for Flame spread and smoke development when tested in accordance with ASTM-E84 and a maximum Flame spread of 25, Smoke development of 50 based on the average of three runs when tested in accordance with CAN/ULC S102.
7. Combustibility: All components of the access floor system shall qualify as noncombustible by demonstrating compliance with requirements of ASTM E 136, Standard Test Method for Behavior of Materials in a Vertical Tube Furnace at 750° C.
8. Recycled Content: Panel and understructure system shall be required to have a minimum recycled content of 50%.

The following applies to TecCrete 2000/2500 Raised Access Flooring only:

1. Concentrated Load: 2,500 lb on one square inch (25mm) load at any location with a top surface deflection not to exceed 0.10" (2.5mm) and a permanent set not to exceed 0.015" (4mm).
 2. Uniform Load: With a top surface deflection not exceeding 0.040" (1mm), TecCrete can hold 1100 pounds per square foot evenly distributed over the surface of the panel with a permanent set not exceeding 0.010" (0.25mm).
 3. Ultimate Load: Panel shall be designed to withstand load greater than 3,100 lbs at weakest point with stringer.
 4. Rolling Load: Panels shall withstand a rolling load of 2,000 lbs. applied through a 3" dia. (76mm) x 1³/₁₆" (46mm) wide caster for 10 cycles over the same path with less than 0.040" top surface permanent set. Panels shall withstand a rolling load of 1,750 lb. applied through a hard rubber-surfaced wheel 6" (152mm) dia. x 4" (102mm) wide for 10,000 cycles over the same path. Permanent set at the conclusion of the test shall not exceed 0.040" (1mm).
 5. Impact Load: A 150 lb. load dropped from 36" (914mm) onto a one-inch square indenter shall not render the system unserviceable.
 6. Flammability: Bare panel system shall meet Class A requirements for Flame spread and smoke development when tested in accordance with ASTM-E84 and a maximum Flame spread of 25, Smoke development of 50 based on the average of three runs when tested in accordance with CAN/ULC S102.
 7. Combustibility: All components of the access floor system shall qualify as noncombustible by demonstrating compliance with requirements of ASTM E 136, Standard Test Method for Behavior of Materials in a Vertical Tube Furnace at 750° C.
 8. Recycled Content: Panel and understructure system shall be required to have a minimum recycled content of 50%.
- C. Product testing shall be completed by an accredited independent testing laboratory with a minimum of five (5) years experience testing access floor components in accordance with CISCA test methods.

PART 1 - GENERAL

1.04 Country of Origin

- A. Access floor materials shall comply with the provisions outlined in FAR Subpart 25.2–Buy American Act–Construction Materials.

1.05 Submittals

- A. Samples: Submit a sample of the floor panel and each understructure component.
- B. Shop Drawings:
 - 1. Submit drawings showing raised floor panel layout including starting point of installation.
 - 2. Include details of components panels, and pedestals. If required show edge details of ramps, steps, handrails, and anchoring of pedestal bases to subfloor.
- C. Certificates:
 - 1. Submit independent testing organization certificates indicating compliance with specified design criteria when tested and reported according to CISCA "Recommended Test Procedures for Access Floors."
 - 2. Submit seismic calculations if required in accordance with local and state building codes as specified. Calculations shall be performed using current seismic program and submitted to a local structural engineer licensed in the state where the project is located. The structural engineer shall sign and seal these calculations confirming that these calculations meet all local and state codes for seismic pedestal assemblies. A signed copy of these calculations must be given to the architect and local building department as required.

1.06 Quality Assurance

- A. Installer: A company with minimum of five years experience in the installation of access floor systems of comparable size and complexity.
- B. Tolerances:
 - 1. Manufacturing tolerance:
 - a) Nominal panel size ± 0.015 " (0.4mm) or less.
 - b) Panel flatness ± 0.020 " (.5mm) or less.
 - c) Panel squareness ± 0.015 " (0.4mm) or less.
 - d) Panel interchangeability — all panels, except those modified to meet special conditions, shall be interchangeable.
 - 2. Installation Tolerance:
 - a) Finished installation shall be level within ± 0.060 " (2mm) in 10 feet (3m) and ± 0.100 " (3mm) for the entire floor.

1.07 Project Conditions

- A. The General Contractor and/or Owner shall provide a clean, level, dry subfloor, temperature controlled, and protected from the weather.
- B. Access flooring storage and installation areas shall be maintained at a temperature between 40° F and 120° F, and between 35% to 70% relative humidity for 24 hours a day before, during and after installation.
- C. Overhead construction work must be completed before installing access floor to avoid damage to panels and finishes. Any damage to panels or finishes resulting from construction work done after floor is installed shall be the responsibility of the general contractor or others.

PART 2 - PRODUCTS

2.01 Materials

- A. Manufacturer: The access flooring system shall be as manufactured by Haworth Inc. located in Grand Rapids, Michigan 49512.
1. Substitutions will be considered, providing the alternative products meet or exceed the feature requirements as indicated herein and the performance requirements including the rolling load as outlined in section 1.06 and receive prior written approval by the Architect. The manufacturer shall certify that all panels meet or exceed the stated design criteria.
- B. Floor Panels: TecCrete 1250/1500 or 2000/2500 Panels shall be integrated steel pan construction with exposed top surface of lightweight concrete fill. Floor Panels are bare cornerlock.
1. Panels shall be nominal 24" (610mm) square x 1½" (29mm) or 1½" (38mm) deep, manufactured with galvanized steel pan having shear tabs that integrally bond to the lightweight, high-strength concrete fill. Panel corners shall be manufactured to receive the pedestal head positioning dome and containing a cornerlock/grounding insert. Each panel shall accept a flush-fit metal fastener which securely fastens each panel corner to the pedestal head.
 2. Panel Finish: Floor panel surface shall be factory standard bare concrete for field installed carpet tile. Panels shall have a maximum electrical resistance of 10 ohms or less from the top edge of the panel, less surface covering, to the understructure.
- C. Air Supply Panels:
1. Provide and/or install passive floor diffusers and factory cutouts as indicated on drawings.
 2. Factory cutouts shall be (centered) (quadrant) as shown. Panels with cutouts that are located in traffic areas as shown on the drawings shall have extra pedestal assemblies under the panel to support the cutout.
 3. For underfloor air applications, provide air strip gaskets for exposed concrete panels, or high-pressure air highways, as indicated.
- D. Understructure:
1. Pedestal assemblies shall be of hot-dip galvanized steel.
 2. The base shall be a minimum of 16 square inches and shall be stamped and/or embossed on its underside and shall be adhered to the subfloor with an adhesive recommended by the access flooring manufacturer.
 3. Where mechanical anchors are required for seismic zones, provide same as required by project specific seismic calculations.
 4. The threaded stud will be ¾" (19mm) diameter steel.
 5. The head assembly shall be designed so that the panels will be held in place with or without cornerlock fasteners.
 6. Pedestal assembly shall provide an adjustment range of +/- 1" (25mm) when finished floor height is 6" (152mm) or more, adjustable at ¼" (0.4mm) increments.
 7. The assembly shall provide a mechanical means to lock the floor in a level plane and adjustments

PART 2 - PRODUCTS

shall be capable of being made without special tools.

8. For cornerlock system, the head of the all-steel assembly shall be designed to accept a metal fastener to mechanically lock the panels in place.
 9. Pedestal assembly shall support not less than 6,000 lb. axial load and shall resist an average 1,000 inch-pound overturning moment when bonded to a clean concrete slab.
- E. Stringers:
1. Stringer shall capture panels and be capable of supporting a 450 lb. concentrated load at mid span with less than 0.010" permanent set after the load is removed.
 2. Stringers shall be individually and rigidly fastened to the pedestal with one machine screw for each foot of stringer length. Bolts shall provide positive electrical contact between the stringers and pedestals. Connections depending on gravity or spring action are unacceptable.
 3. Stringer shall be either 2' x 2' or 4' x 4' pattern and shall be secured by a fastener.
- F. Accessories:
1. Furnish ramps, steps, lateral bracing, fascia, handrails, cutouts, and miscellaneous items where indicated.
 2. Manufacturer of the access floor shall also provide a modular power system, including in-floor service outlets for power, communications, and data wiring in locations as shown on Drawings.
 - a. Zone Distribution Box: Used as transition point to convert from bulk power distribution into easily reconfigurable modular power distribution components. Supports "plug-and-play" power distribution within each power zone.
 - i. 3-Port Distribution box is constructed of 0.0575" – 0.0635" (16 gauge) thick black zinc plated steel box with cover. Provided with one 1¼" conduit containing 21 - 10 AWG wires in lengths up to 125 feet. This is intended to be connected to the building Circuit Breaker box. Three modular ports are factory wired, ready for modular jumpers. Available in 8 wire 3- or 4-Circuit wiring configuration.
 - ii. 2-Port Distribution box is constructed of 0.0575" – 0.0635" (16 gauge) thick black zinc plated steel box with cover. Provided with one 1¼" conduit containing 14 - 8 AWG wires in lengths of 150 to 200 feet. This is intended to be connected to the building Circuit Breaker box. Two modular ports are factory wired, ready for modular jumpers. Available in 8 wire 3- or 4-circuit wiring configuration.
 - iii. Field Wired Distribution box is constructed of 0.0575" – 0.0635" (16 gauge) thick black zinc plated steel box with cover. This is intended to be connected to the building Circuit Breaker box by a licensed electrician using 1¼" conduit and appropriately sized wire. Terminal strips inside the box are connected to three modular ports, which are factory wired, ready for modular jumpers. Available in 8 wire 3- or 4-Circuit wiring configuration.
 - iv. Low Profile Distribution box is constructed of 0.0575" – 0.0635" (16 gauge) thick black zinc plated steel box with cover. This is intended to be connected to the building Circuit Breaker box by a licensed electrician using ½" conduit and appropriately sized wire. Wire leads inside the box are connected to a modular port, ready for a modular jumper. Available in 8 wire 3- or 4-Circuit wiring configuration.
 - b. Jumpers: Used to interconnect modular power components within each power zone. Flexible conduit construction with quick connect modular male power connector heads. Available in 8 wire 3-or 4-Circuit wiring configuration. Connector populated with all 8 wires to support future reconfigurations of the power distribution system. Available in 5', 10' 15' and 20' lengths. Available with either all 10 gauge or 10/12 gauge wires, all 10 gauge is a ¾" oval flexible metal conduit and the 10/12 gauge is ⅝" ovalflexible metal conduit.

PART 2 - PRODUCTS

- c. Splitters: Act as 'splitter' to interconnect up to four Jumpers within each power zone. Constructed with 8 tin plated copper busbars within polymeric enclosure with integral latching system. Available in 3- or 4-Circuit configurations. Typically one acts as the inlet and the others are outbound branches.
- d. Service Modules: Used to provide power and/or data outlets at floor level.
 - i. 2.5" Dual Flush Service Module constructed of 0.0575 – 0.0635" (16 gauge) thick black zinc plated steel box with 2 integral female connectors. Receptacle/Data plates are concealed under hinged lid. Powdercoat painted (black) lid and trim ring with hinged cord exit port. Lid accepts carpet insert. Unit fits in 10½" square opening in raised access floor tile. Unit is secured to floor tile using four mounting screws. Available in 8 wire 3- or 4-Circuit configurations. Unit accepts two modular receptacles, which are specified separately, with common or isolated ground receptacles. Available in 2.5" 2-gang configuration.
 - ii. 4.5" Quad Flush Service Module constructed of 0.0575 – 0.0635" (16 gauge) thick black zinc plated steel box with 4 integral female connectors. Receptacle/Data plates are concealed under hinged lid. Powdercoat painted (black) lid and trim ring with hinged cord exit port. Lid accepts carpet insert. Unit fits in 10½" square opening in raised access floor tile. Unit is secured to floor tile using four mounting screws. Available in 8 wire 3- or 4-Circuit configurations. Unit accepts four modular receptacles, which are specified separately, with common or isolated ground receptacles. Available in 4.5" 4-gang configuration.
- e. Systems Furniture Feed: Used to connect systems furniture modular wiring directly to zone power distribution.
 - i. Haworth Base Feeds are constructed with male connector head for quick connect attachment to Jumpers of zone power system. Available in 3- or 4-Circuit configuration, depending on type of power available in the Haworth Furniture. Base feeds are UL/CSA listed for direct connection to the Jumpers.

PART 3 - EXECUTION

3.01 Inspection

- A. Examine the subfloor which is to receive access flooring for dryness, cleanliness, unevenness, or any irregularities that will affect the quality of the access flooring.
 - 1. Verify that material storage and installation areas are at recommended temperature and relative humidity before, during, and after installation.
 - 2. Verify that substrate is level to within $\frac{1}{8}$ " (3mm) in 10' (3m).
 - 3. Do not commence installation of access flooring until subfloor is clean and dry, temperature controlled, and protected from the weather.

3.02 Installation

- A. Pedestal locations shall be established from approved shop drawings so that mechanical and electrical work can be installed without interfering with pedestal locations.
- B. Installer is to coordinate with other trades to maintain the integrity of the installed access flooring. All traffic on access floor shall be controlled by the installer only. No traffic other than the access floor installation crew shall be permitted on any floor area for 48 hours to allow the pedestal adhesive to set. Access floor panels shall not be removed by other trades for 72 hours after their installation.
- C. Floor system and accessories shall be installed by an authorized factory-trained installation company with a minimum of five (5) years experience.
- D. No dust or debris producing operations by other trades shall be allowed in areas where access floor is being installed to ensure proper bonding of pedestals to subfloor.
- E. Installer shall keep the subfloor broom clean as installation progresses.
- F. Install floor diffusers if required as indicated on Mechanical Plans.
- G. Finished installation shall be level within +/- 0.060" (2mm) in 10' (3m) and +/- 0.100" (3mm) for the entire floor area.
- H. Replace damaged materials prior to the application of field applied surfaces.
- I. **The General Contractor or Subcontractor shall assure compatibility between the concrete sealer and the pedestal adhesive provided by the access floor manufacturer.**

3.03 Acceptance

- A. General Contractor or Owner shall accept completed access floor in whole or in part, prior to allowing other trades to perform work which affects the installed access floor.
- B. General Contractor shall suitably protect the accepted access floor and accessories from damage, contamination, or overloading.
- C. The General Contractor shall be responsible for the final underfloor cleaning.

This page intentionally left blank.

TecCrete Access Flooring: Computer Rooms

Three Part Guide Specification

PART 1 - GENERAL

An editable Microsoft® Word version of this document is available for download at www.haworth.com.

1.01 Description

- A. The access floor system shall consist of interchangeable panels, understructure, and all labor, material, equipment, and installation as called for in the specifications and/or shown on the Architect's Drawings.
- B. Access floor manufacturer shall be ISO9001:2000 certified demonstrating it has a robust and well documented quality management system with continual improvement goals and strategies.
- C. Access floor manufacturer's facilities shall be ISO14001:2004 certified demonstrating that they maintain an environmental management system.
- D. Access floor product must be indoor air quality certified to conform to CA Section 01350 Specification for classroom and standard office.
- E. Access floor product shall be manufactured in a zero landfill facility.
- F. Related Work Specified Elsewhere:
 - 1. Concrete work and concrete floor sealer is specified in Section 03 30 00.
 - a) Concrete sealer and pedestal adhesive must be chemically compatible with each other.
 - 2. Carpet and carpet tile work as specified in Section 09 68 00 (09680 MasterFormat 95).
 - 3. Mechanical air distribution as specified in Section 23 30 00 (15800 MasterFormat 95).
 - 4. Electrical connections, grounding, and modular power systems as specified in Section 26 05 00 (16100 Master Format 95).

1.02 Environmental Conditions for Storage and Installation

- A. The General Contractor must provide a dry accessible area to receive and unload material with a free path to elevators, hoists, and/or the area receiving the access floor.
- B. Prior to and during installation, a secure and dry storage space closed to the weather must be made available for the access floor materials, with recommended environment at 40° F to 120° F and approximately 35% to 70% relative humidity, 24 hours a day during and after installation.
- C. The subfloor surface must be free of moisture, dust, dirt and other debris. Once installed, the access floor must be maintained in the same manner.

1.03 Design Performance and Certification of Product

- A. Provide access flooring system consisting of moveable assemblies composed of modular floor panels supported on pedestals forming accessible underfloor cavities to accommodate electrical, mechanical, and HVAC services and complying with performance requirements specified. Raised Floor panels must be interchangeable with each other except where cut for special conditions.
- B. Where applicable load testing shall be performed according to "Recommended Test Procedures for Access Flooring" as established by the Ceiling and Interior Systems Construction Association (CISCA). These procedures shall be used as a guideline when presenting load performance product information.

PART 1 - GENERAL

The following applies to TecCrete 1250 Raised Access Flooring only:

1. Concentrated Load: 1,250 lb. on one square inch (25mm) at any location with a top surface deflection not to exceed 0.10" (2.5mm), and a permanent set not to exceed 0.010" (0.25mm).
2. Uniform Load: With a top surface deflection not exceeding 0.040" (1mm), TecCrete can hold 600 pounds per square foot evenly distributed over the surface of the panel with a permanent set not exceeding 0.010" (0.25mm).
3. Ultimate Load: 1,800 lb. per square inch minimum at weakest point.
4. Rolling Load: Panels shall withstand a rolling load of 1,200 lbs. applied through a 3" (76mm) dia. x 1³/₁₆" (46mm) wide caster for 10 cycles over the same path with a maximum of 0.040" (1mm) top surface permanent set. Panels shall withstand a rolling load of 800 lb. applied through a hard rubber-surfaced wheel 6" (152mm) dia. x 2" (51mm) wide for 10,000 cycles over the same path with a maximum of 0.040" (1mm) top surface permanent set.
5. Impact Load: A 150 lb. load dropped from 36" (914mm) onto a one-inch square indenter shall not render the system unserviceable.
6. Flammability: Bare panel system shall meet Class A requirements for Flame spread and smoke development when tested in accordance with ASTM-E84 and a maximum Flame spread of 25, Smoke development of 50 based on the average of three runs when tested in accordance with CAN/ULC S102.
7. Combustibility: All components of the access floor system shall qualify as noncombustible by demonstrating compliance with requirements of ASTM E 136, Standard Test Method for Behavior of Materials in a Vertical Tube Furnace at 750° C.
8. Recycled Content: Panel and understructure system shall be required to have a minimum recycled content of 50%.

The following applies to TecCrete 1500 Raised Access Flooring only:

1. Concentrated Load: 1,500 lb on one square inch (25mm) load at any location with a top surface deflection not to exceed 0.10" (2.5mm) and a permanent set not to exceed 0.010" (0.25mm).
2. Uniform Load: 700 lb. per square foot with a maximum top surface deflection not to exceed 0.040" (1 mm), and a permanent set not to exceed 0.010" (0.25mm).
3. Ultimate Load: With a top surface deflection not exceeding 0.040" (1mm), TecCrete can hold 700 pounds per square foot evenly distributed over the surface of the panel with a permanent set not exceeding 0.010" (0.25mm).
4. Rolling Load: Panels shall withstand a rolling load of 1,500 lbs. applied through a 3" dia. (76mm) x 1³/₁₆" (46mm) wide caster for 10 cycles over the same path with less than 0.040" top surface permanent set. Panels shall withstand a rolling load of 1,250 lb. applied through a hard rubber-surfaced wheel 6" (152mm) dia. x 2" (51mm) wide for 10,000 cycles over the same path. Permanent set at the conclusion of the test shall not exceed 0.040" (1mm).
5. Impact Load: A 150 lb. load dropped from 36"(914mm) onto a one-inch square indenter shall not render the system unserviceable.

PART 1 - GENERAL

6. **Flammability:** Bare panel system shall meet Class A requirements for Flame spread and smoke development when tested in accordance with ASTM-E84 and a maximum Flame spread of 25, Smoke development of 50 based on the average of three runs when tested in accordance with CAN/ULC S102.
7. **Combustibility:** All components of the access floor system shall qualify as noncombustible by demonstrating compliance with requirements of ASTM E 136, Standard Test Method for Behavior of Materials in a Vertical Tube Furnace at 750° C.
8. **Recycled Content:** Panel and understructure system shall be required to have a minimum recycled content of 50%.

The following applies to TecCrete 2000/2500 Raised Access Flooring only:

1. **Concentrated Load:** 2,500 lb on one square inch (25mm) load at any location with a top surface deflection not to exceed 0.10" (2.5mm) and a permanent set not to exceed 0.015" (4mm).
 2. **Uniform Load:** With a top surface deflection not exceeding 0.040" (1mm), TecCrete can hold 1100 pounds per square foot evenly distributed over the surface of the panel with a permanent set not exceeding 0.010" (0.25mm).
 3. **Ultimate Load:** Panel shall be designed to withstand load greater than 3,100 lbs at weakest point with stringer.
 4. **Rolling Load:** Panels shall withstand a rolling load of 2,000 lbs. applied through a 3" dia. (76mm) x 1³/₈" (46mm) wide caster for 10 cycles over the same path with less than 0.040" top surface permanent set. Panels shall withstand a rolling load of 1,750 lb. applied through a hard rubber-surfaced wheel 6" (152mm) dia. x 4" (102mm) wide for 10,000 cycles over the same path. Permanent set at the conclusion of the test shall not exceed 0.040" (1mm).
 5. **Impact Load:** A 150 lb. load dropped from 36" (914mm) onto a one-inch square indenter shall not render the system unserviceable.
 6. **Flammability:** Bare panel system shall meet Class A requirements for Flame spread and smoke development when tested in accordance with ASTM-E84 and a maximum Flame spread of 25, Smoke development of 50 based on the average of three runs when tested in accordance with CAN/ULC S102.
 7. **Combustibility:** All components of the access floor system shall qualify as noncombustible by demonstrating compliance with requirements of ASTM E 136, Standard Test Method for Behavior of Materials in a Vertical Tube Furnace at 750° C.
 8. **Recycled Content:** Panel and understructure system shall be required to have a minimum recycled content of 50%.
- C. Product testing shall be completed by an accredited independent testing laboratory. with a minimum of five (5) years experience testing access floor components in accordance with CISCA test methods.

1.04 Country of Origin

- A. Access floor materials shall comply with the provisions outlined in FAR Subpart 25.2–Buy American Act–Construction Materials.

1.05 Submittals

PART 1 - GENERAL

- A. Samples: Submit a sample of the floor panel and each understructure component.
- B. Shop Drawings:
 - 1. Submit drawings showing raised floor panel layout including starting point of installation.
 - 2. Include details of floor panel layout including ramps, steps, handrails and anchoring of pedestal bases to subfloor and panel edge details.
- C. Certificates:
 - 1. Submit independent testing organization certificates indicating compliance with specified design criteria when tested and reported according to CISCA "Recommended Test Procedures for Access Floors."
 - 2. Submit seismic calculations if required in accordance with local and state building codes as specified. Calculations shall be performed using current seismic program and submitted to a local structural engineer licensed in the state where the project is located. The structural engineer shall sign and seal these calculations confirming that these calculations meet all local and state codes for seismic pedestal assemblies. A signed copy of these calculations must be given to the architect and local building department as required.

1.06 Quality Assurance

- A. Installer: A company with minimum of five years experience in the installation of access floor systems of comparable size and complexity.
- B. Tolerances:
 - 1. Manufacturing tolerance:
 - a) Nominal panel size ± 0.015 " (0.4mm) or less.
 - b) Panel flatness ± 0.020 " (0.5mm) or less.
 - c) Panel squareness ± 0.015 " (0.4mm) or less.
 - d) Panel interchangeability — all panels, except those modified to meet special conditions, shall be interchangeable.
 - 2. Installation Tolerance:
 - a) Finished installation shall be level within ± 0.060 " (2mm) in 10 feet (3m) and ± 0.100 " (3mm) for the entire floor.

1.07 Project Conditions

- A. The General Contractor and/or Owner shall provide a clean, level, dry subfloor, temperature controlled, and protected from the weather.
- B. Access flooring storage and installation areas shall be maintained at a temperature between 40° F and 120° F, and between 35% to 70% relative humidity for 24 hours a day before, during and after installation.
- C. Overhead construction work must be completed before installing access floor to avoid damage to panels and finishes. Any damage to panels or finishes resulting from construction work done after floor is installed shall be the responsibility of the General Contractor or others.

PART 2 - PRODUCTS

2.01 Materials

- A. Manufacturer: The access flooring system shall be as manufactured by Haworth Inc. located in Grand Rapids, Michigan 49512.
1. Substitutions will be considered, providing the alternative products meet or exceed the feature requirements as indicated herein and the performance requirements including the rolling load as outlined in section 1.03 and receive prior written approval by the Architect. The manufacturer shall certify that all panels meet or exceed the stated design criteria.
- B. Floor Panels: TecCrete 1250/1500 or 2000/2500 Panels shall be integrated steel pan construction with exposed top surface of lightweight concrete fill covered with a factory applied finish.
1. Panels shall be nominal 24" (610mm) square x 1 1/8" (29mm) deep or 1 1/2" (38mm) deep, manufactured with galvanized steel pan having shear tabs that integrally bond to the lightweight, high-strength concrete fill. Panel corners shall be manufactured to receive the pedestal head positioning dome and containing a cornerlock/grounding insert. Each panel shall accept a flush-fit metal fastener which securely fastens each panel corner to the pedestal head or stringer.
 2. Panel Finish: Floor panel surface shall be factory applied 1/8" or 1/16" thick high-pressure laminate, static dissipative or conductive vinyl as indicated on the Architectural Plans. High-pressure laminates shall be optionally finished with the TecTrim edge. One-piece vinyl tile shall be optionally finished at the edges with vinyl trim, as indicated on the Architectural Plans. Panels shall have a maximum electrical resistance of 10 ohms or less from the top edge of the panel to the understructure, less surface covering, as tested according to NFPA 99 modified.
- C. Air Supply Panels:
1. Provide and/or install passive floor diffusers and factory cutouts as indicated on drawings.
 2. Factory cutouts shall be (centered) (quadrant) as shown. Panels with cutouts that are located in traffic areas as shown on the drawings shall have extra pedestal assemblies under the panel to support the cutout.
 3. For underfloor air applications, provide air strip gaskets for exposed concrete panels, or high-pressure air highways, as indicated.
- D. Understructure:
1. Pedestal assemblies shall be galvanized steel.
 2. The base shall be a minimum of 16 square inches and shall be stamped and/or embossed on its underside and shall be adhered to the subfloor with an adhesive recommended by the access flooring manufacturer.
 3. Where mechanical anchors are required for seismic zones, provide same as required by project specific seismic calculations.
 4. The threaded stud will be 3/4" (19mm) diameter steel.
 5. The head assembly shall be designed so that the panels will be held in place with or without cornerlock fasteners.

PART 2 - PRODUCTS

6. Pedestal assembly shall provide an adjustment range of +/- 1" (25mm) when finished floor height is 6" (152mm) or more, adjustable at 1/4" (0.4mm) increments without rotating pedestal head.
 7. The assembly shall provide a mechanical means to lock the floor in a level plane and adjustments shall be capable of being made without special tools.
 8. For cornerlock system, the head of the all-steel assembly shall be designed to accept a metal fastener to mechanically lock the panels in place.
 9. Pedestal assembly shall support not less than 6,000 lb. axial load and shall resist an average 1,000 inch-pound overturning moment when bonded to a clean concrete slab.
- E. Stringers:
1. Stringer shall capture panels and be capable of supporting a 450 lb. concentrated load at mid span with less than 0.010" permanent set after the load is removed.
 2. Stringers shall be individually and rigidly fastened to the pedestal with one machine screw for each foot of stringer length. Bolts shall provide positive electrical contact between the stringers and pedestals. Connections depending on gravity or spring action are unacceptable
 3. Stringer shall be either 2' x 2' or 4' x 4' pattern and shall be secured by a fastener.
- F. Accessories:
1. Furnish ramps, steps, lateral bracing, fascia, handrails, cutouts and miscellaneous items where indicated.
 2. Provide modular power system, including in-floor service outlets for power, communications, and data wiring in locations as shown on Drawings.

PART 3 - EXECUTION

3.01 Inspection

- A. Examine the subfloor which is to receive access flooring for dryness, cleanliness, unevenness, or any irregularities that will affect the quality of the access flooring.
 - 1. Verify that material storage and installation areas are at recommended temperature and relative humidity before, during, and after installation.
 - 2. Verify that substrate is level to within $\frac{1}{8}$ " (3mm) in 10 feet (3m).
- B. Do not commence installation of access flooring until subfloor is clean and dry, temperature controlled, and protected from the weather.

3.02 Installation

- A. Pedestal locations shall be established from approved shop drawings so that mechanical and electrical work can be installed without interfering with pedestal locations.
- B. Installer is to coordinate with other trades to maintain the integrity of the installed access flooring. All traffic on access floor shall be controlled by the installer only. No traffic other than the access floor installation crew shall be permitted on any floor area for 48 hours to allow the pedestal adhesive to set. Access floor panels shall not be removed by other trades for 72 hours after their installation.
- C. Floor system and accessories shall be installed by an authorized factory-trained installation company with a minimum of five (5) years experience.
- D. No dust or debris producing operations by other trades shall be allowed in areas where access floor is being installed to ensure proper bonding of pedestals to subfloor.
- E. Installer shall keep the subfloor broom clean as installation progresses.
- F. Install floor diffusers if required as indicated on Mechanical Plans.
- G. Finished installation shall be level within ± 0.060 " (2mm) in 10 feet (3m) and ± 0.100 " (3mm) for the entire floor area.
- H. Replace damaged materials prior to the application of field applied surfaces.
- I. The General Contractor or Subcontractor shall assure compatibility between the concrete sealer and the pedestal adhesive provided by the access floor manufacturer.

3.03 Acceptance

- A. General Contractor or Owner shall accept completed access floor in whole or in part, prior to allowing other trades to perform work which affects the installed access floor.
- B. General Contractor shall suitably protect the accepted access floor and accessories from damage, contamination, or overloading.
- C. The General Contractor shall be responsible for the final underfloor cleaning.

This page intentionally left blank.

This page intentionally left blank.

HAWORTH®

For more information call 800.344.2600 or 616.393.3000.



Cover is printed on 100% chlorine-free paper. Internal pages are manufactured with 10% post-consumer fiber.

Haworth is a registered trademark of Haworth, Inc.
Printed in USA ©Haworth, Inc. 2009 07.09 Item #1238

haworth.com | haworth-europe.com | haworth-asia.com