

COUNTRY[®] ESTATE FENCE



RAIL FENCE PLANNING & INSTALLATION GUIDE

TABLE OF CONTENTS

Description	Page No.
General Information	3
Sketch a Layout	3
Allow for Slope	5
Allow for Expansion and Contraction	5
Post Spacing	7
Standard Rail Spacing	7
Post Depth	7
Setting Posts and Post Footings	10
Gate Posts	12
Gates and Gate Hardware	13
 Installing Rail Fencing with Brackets	 14
 Installing Rail Fencing with Routed Posts and Notched Rails/Rail Locks/Spring Clips	 16
Warranty	19

Country Estate installation practices and recommendations do not purport to address all of the safety concerns and/or local code requirements, associated with it's use. It is the responsibility of the user of these prescribed installation practices to establish appropriate safety, health, and installation practices and determine the applicability of regulatory limitations prior to use.

Safety — All work shall be performed in safe and orderly fashion in accordance with the Williams-Steiger Occupational Safety and Health Act of 1970.

For more information on



Call Toll-Free
1-800-445-2887
1-308-784-2500



NEBRASKA PLASTICS, INC.
 P.O. Box 45 • Cozad, NE 69130 • FAX (308) 784-3216

GENERAL INFORMATION

Country Estate Fencing is known for its ease of installation. Other than the need to allow for greater expansion and contraction than is typical with traditional fencing materials, all of the techniques used by experienced fence installers is directly applicable to Country Estate Fencing products. This guide shares techniques developed by experienced installers and is offered to make your installation as easy and as professional as possible.

PLANNING YOUR PROJECT

There are a number of decisions you must make before ordering your Country Estate Fence. Although each project is different, there are some considerations which are common to every project. The following information is offered to assist you. If you have questions not covered here, please ask your Country Estate representative for assistance.

SKETCH A LAYOUT

Drive stakes to locate proposed corner posts and gate posts. Look for obstacles in the proposed fence line (trees, bushes, structures, etc.). Measure the distances between the stakes and take a few moments to sketch a layout of your project. Consider which direction you want your gates to swing. Some neighborhoods have building codes which restrict fence height and set back from property lines. If you are planning a property line fence, you will want to confirm your property lines before ordering your fence.

KNOW ABOUT LOCAL ORDINANCES

Building permits are typically required in most new installations. Local codes may require clearances or have height restrictions. Where an existing fence is being replaced, permits are not usually required — but it is good to investigate before beginning.

CHECK WITH YOUR LOCAL UTILITY COMPANIES

As a safety precaution, allow the utility companies to mark the location of buried lines, pipes and/or cables. Most companies will do this free of charge.



**All Country Estate® PVC Products
may be Recycled.**



Typical routed post design.

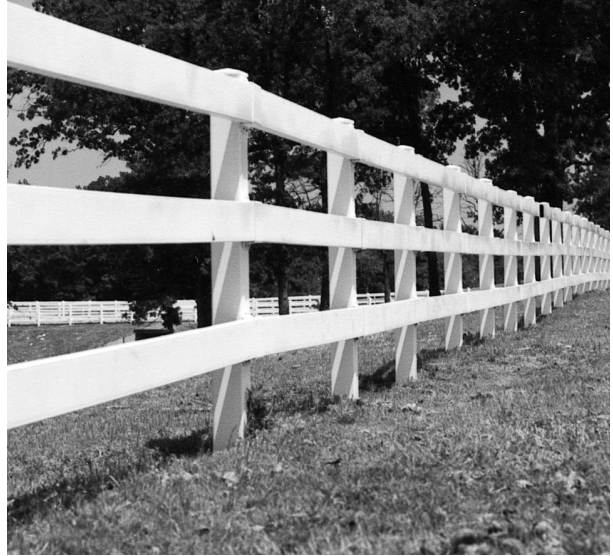

Post and bracket mount.



Round rail routed post design.



CAUTION

Failure to follow recommended installation procedures will result in loss of Manufacturer's Warranty. Alternate procedures or post spacing in excess of 8'-1/2" will require a Written Authorization from Nebraska Plastics, Inc., to retain warranty rights.

ALLOW FOR SLOPE

How to check for slope.

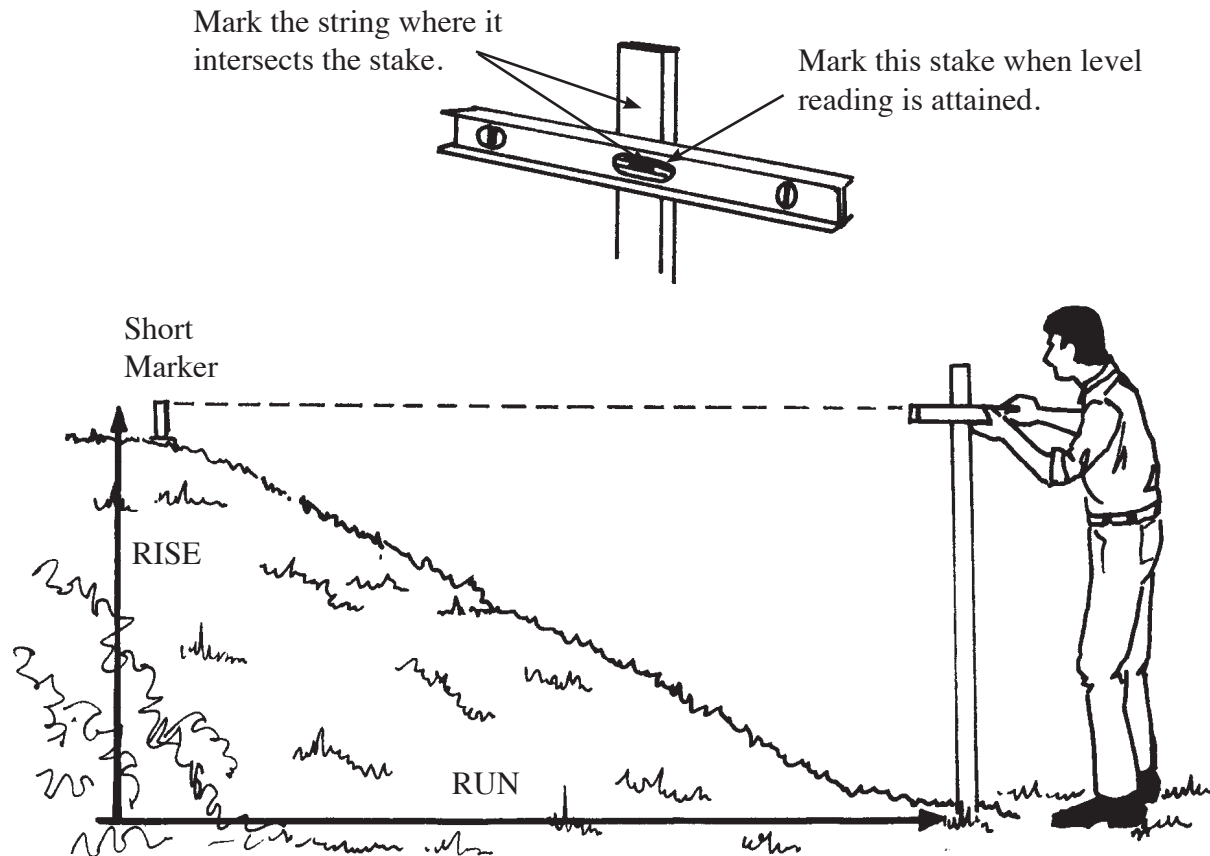

The slope-gauging method pictured above may be used to estimate the amount of slope on the site to be fenced. While this method is not as exact as using a transit or laser, it can be used to determine whether the slope is great enough that it must be considered in the installation. On extremely steep grades 8' rails should be considered to facilitate ease of installation.

ALLOW FOR EXPANSION AND CONTRACTION

Due to their many advantages, vinyl building products have gained wide acceptance. However, vinyl products experience greater expansion and contraction from temperature changes than wood and metal. (A 100° F temperature change will cause a 16' PVC fence rail to expand or contract approximately 5/8".) Country Estate's rail fencing may be constructed with either post brackets or routed posts with either notched rails or rail locks. When properly installed, both systems provide for an expansion gap between the ends of the rails. This gap allows space for the rails to expand and contract.

Continued on next page.

POST BRACKETS

With bracketed fencing, the expansion gap is hidden in the center of the bracket. The center of each 16' rail should be restrained to the post or bracket. This allows the ends of the rail to expand and contract under the post brackets. Eight foot rails should be restrained at one end. To restrain bracketed rails, screw a stainless steel screw through the bottom of the bracket and into the rail. By placing the screw in this location, the screw will not be seen and the screw head will not create a rough surface for horses to rub on. (See illustration on page 8.)

On bracketed fencing, failure to center the expansion gaps will result in insufficient seating depth in the bracket which may allow the rail to fall out during cold weather or deflection of the fence. During hot weather, an insufficient gap may cause the rails to appear to have warped.

ROUTED POSTS WITH NOTCHED RAILS/RAIL LOCKS/SPRING CLIPS (Round Rail Only)

With notched rails, rail locks or spring clips, the expansion gaps occur in the center of the routed post. If the rails do not extend into the post far enough, cold weather may cause them to pull out. If the ends of the rails butt against each other on the inside of the post, warm weather may cause them to appear to have warped. (See illustration on page 8.)

If, during installation, the post spacing and straightness cannot be controlled sufficiently, it is best to set posts slightly less than 8 feet apart and trim the planks as necessary to assure proper fit. Additional information and a drawing of a typical 4-rail installation can be found on page 8.

IMPORTANT —

With bracketed, notched rails, rail locks, and spring clips, the ends of the rails must be installed with gaps to allow for expansion. These gaps should vary from 1/4" when installed on hot summer days to 1/2" when installed on cold days.

- With brackets, the expansion gaps must always be centered on the post.
- With brackets, the 16' rails must be restrained at the center of each rail. The 8' rails must be restrained at one end of each rail.

POST SPACING

With rail fencing, the maximum recommended spacing is 8'-1/2" from post center to post center. Rails are available in 16' standard lengths. The posts in the illustration on page 8 have been cut-away to allow a view of the actual configuration inside the post. If the rails are hung on the side of the posts with mounting brackets, allow the same combination of spacing and staggered rail ends. The rail joints are staggered every other rail (Use a combination of 8' and 16' rails at the starting points).

STANDARD RAIL SPACING

These standard measurements apply to both 1-1/2" x 5-1/2" rails, 2"x 6" rails, and 3" round rails.

- On all Country Estate rail fencing, the top rail is mounted 2" from the top of the post.
- On two-rail and three-rail fencing, there is 11 inches between rails.
- On four-rail fencing, there is 9 inches between the rails.
- Other spacings may be designated based on special applications.

POST DEPTH RECOMMENDATIONS

Determining the post depth you want to use is very important because no fence is better than the stability of its posts. But many conditions may affect your decision with regard to post depth. Following is a list of considerations, but due to regional differences, this list should not be considered all inclusive. Consider each carefully and also check with local or regional installers for specifics in your area.

- General Rule: To determine post depth, divide the total above ground height of fence (including infill) by 3, (Height divided by 3 = minimum post depth).
- Areas with extreme frost depth or ground heave should consider post depths one foot deeper than what is considered normal in milder climates.
- Where there are light, unstable soils, use deeper post depths.
- Weather conditions (wind levels) are very important!!!
- High traffic areas (children climbing/playing).
- Weight of the fence per lineal foot. This is more significant with privacy fences than with rail fences.

Typical Staggered Four-Rail Fence Installation.

(The measurements between rails are for 2" x 6" rails.)

This staggered-rail technique is also applicable on two and three rail fencing, and it also applies to routed posts and notched rails. In this sketch, we have not drawn the brackets so that you can see how the expansion gap should be centered on the post. The center of the rails are anchored to the post bracket with a screw. Joints are staggered every other rail. Where necessary, use 8' rails at starting and ending points. With bracketed fencing, the ends of the rails remain "floating" within post brackets to allow for expansion and contraction. With routed posts and notched rails, the ends of the rails "float" on the inside of the posts.

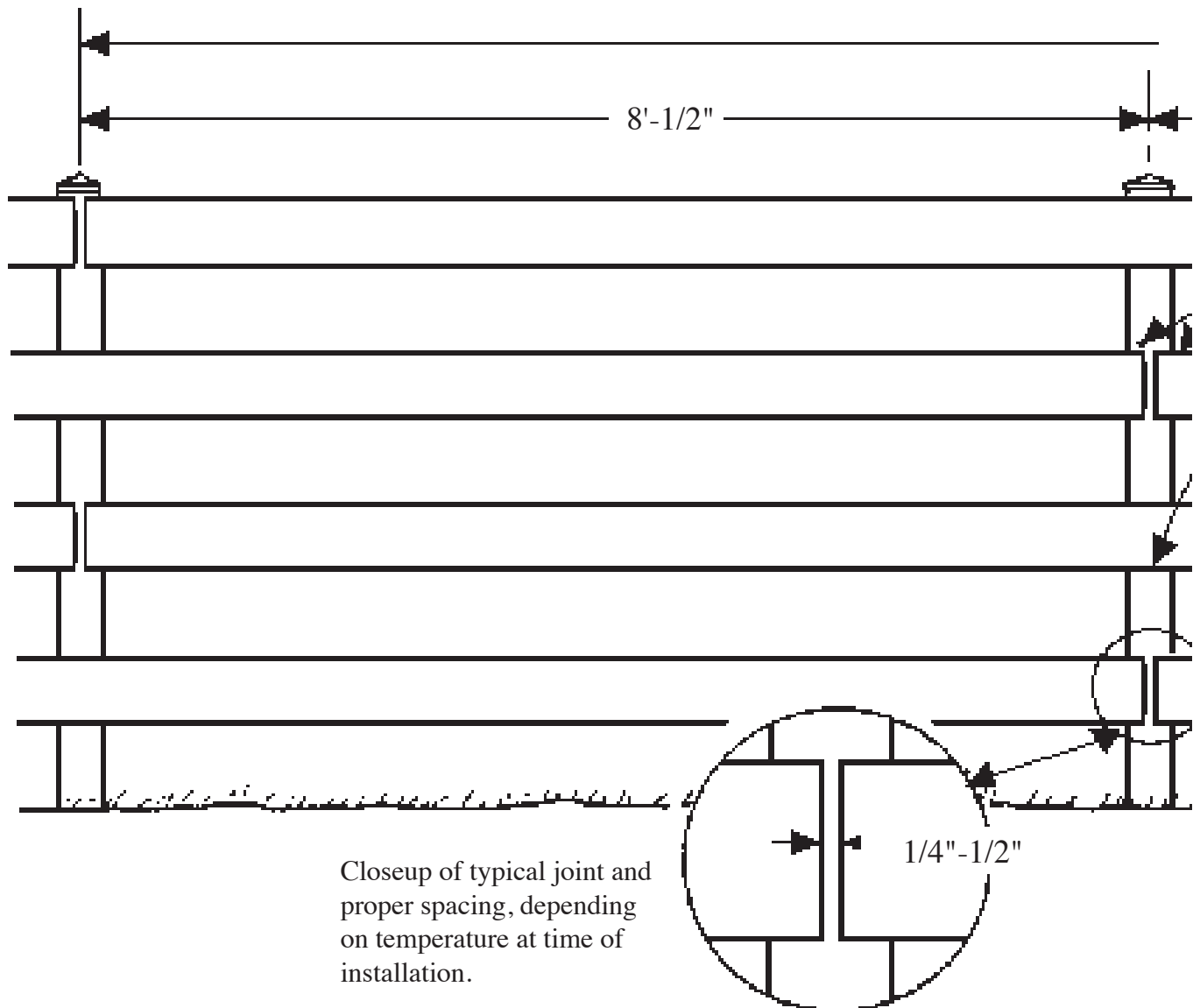

Country Estate installation practices and recommendations do not purport to address all of the safety concerns and/or local code requirements, associated with it's use. It is the responsibility of the user of these prescribed installation practices to establish appropriate safety, health, and installation practices and determine the applicability of regulatory limitations prior to use.

Safety — All work shall be performed in safe and orderly fashion in accordance with the Williams-Steiger Occupational Safety and Health Act of 1970.

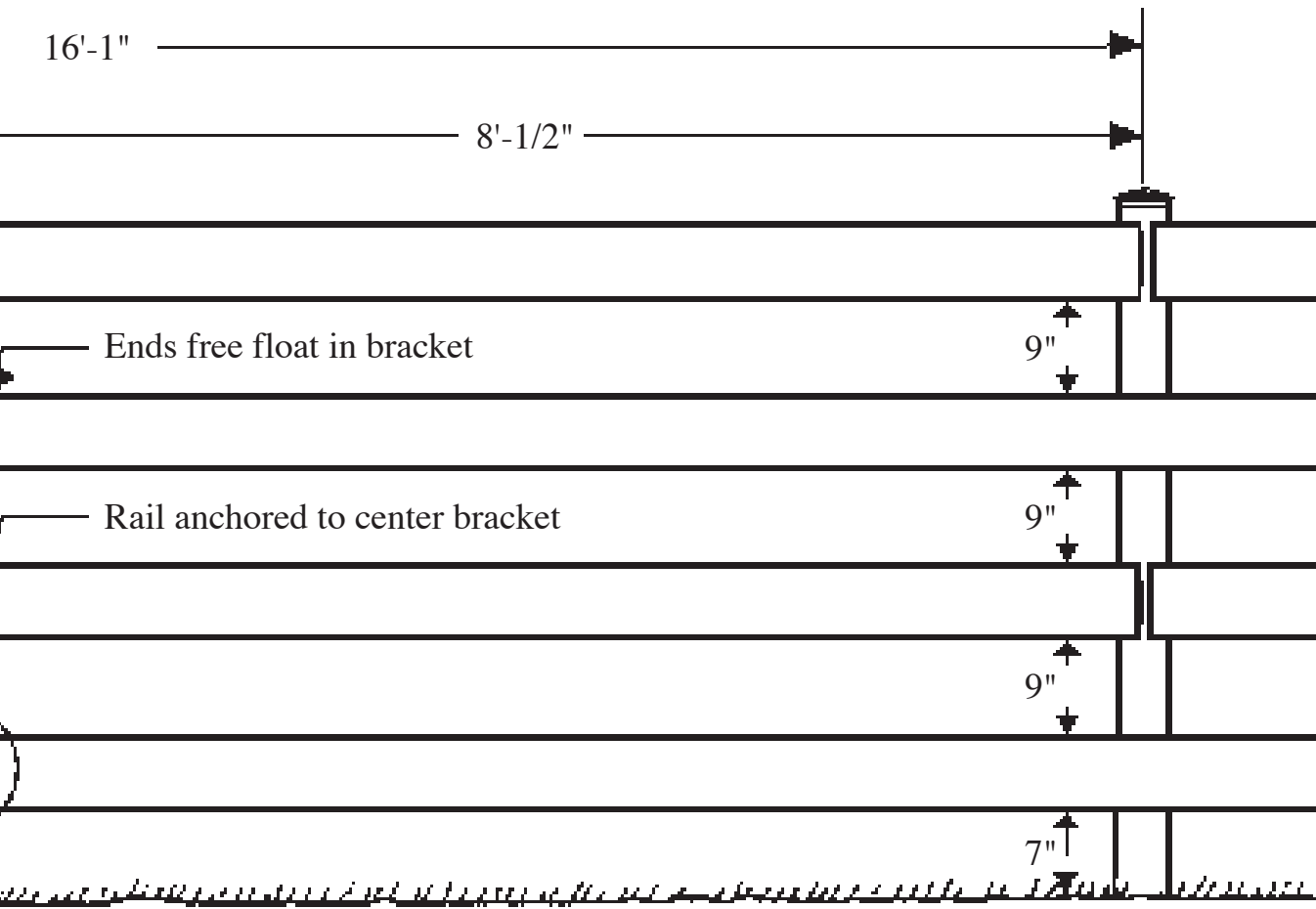

SETTING POSTS AND POST FOOTINGS

To assure a straight and level fence for the life of the material, the installation of the posts is very important. Before digging or augering your post holes, set a string line or steel cable to assist in determining the proper location of your post holes. Country Estate fence recommends using a steel cable for several reasons. Steel cables do not stretch like string and other materials, and you can have the post hole centers marked on the steel cable. The markings will assure accuracy and ease of placement. (See drawing)

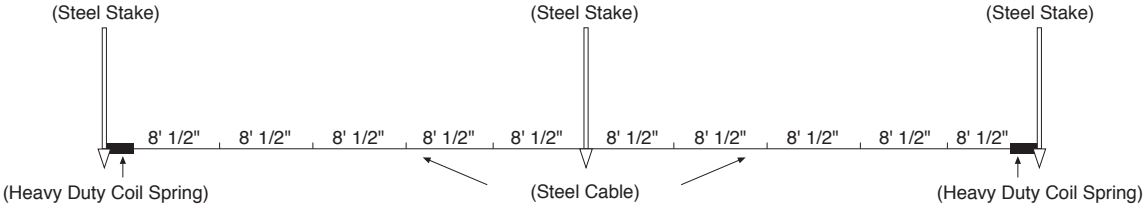

The steel stakes should be very secure to maintain accuracy. For convenience, the steel cable should have a heavy-duty spring and hook at each end of the cable. This provides for the removal of the cable while digging or augering the hole. When you wish to check post hole centers, you simply re-hook the cable to the steel stake.

POST FOOTINGS-INSTALLATION OF POSTS (IN ACCORDANCE WITH ASTM F1999)

Adequate post footings are required to assure a straight and level fence for the life of the material. The following sketch shows four different accepted footings, for specific conditions. Due to the added stability provided, concrete is generally preferred. You may use either wet concrete or a dry-pre-mix concrete. Dry-pre-mix has the advantage that it can be backfilled and tamped like dirt. This allows installers to continue working and not have to wait for the concrete to set. Dry-pre-mix concrete draws moisture from the earth and after seven to ten days it will be as strong as wet concrete.

Due to the added stability provided, concrete is generally preferred; however, in some areas, dirt fill is used.

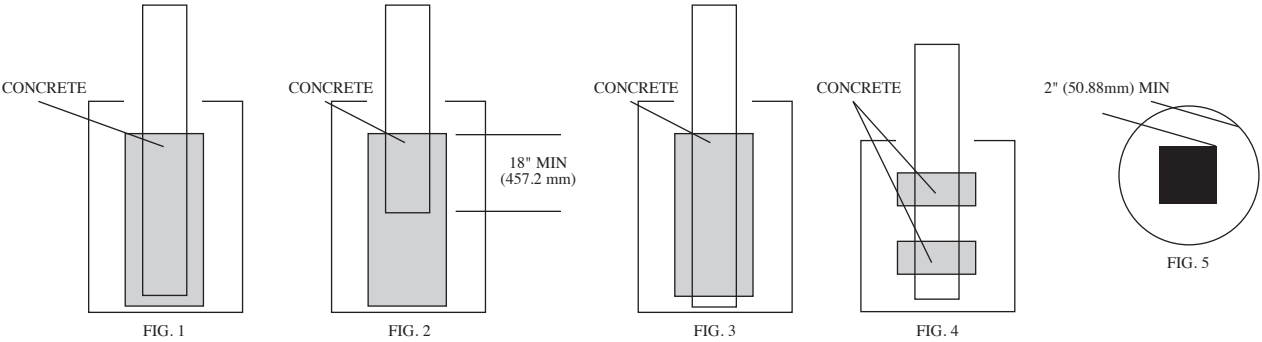

Preparation of Post Holes:

Set posts in concrete in holes of diameter and depth as follows. Intended use and local conditions shall determine post-footing dimensions, that is, under normal conditions the diameter shall be 4 in. (101 mm) greater than the largest cross section of the post. The depth shall be a minimum of 24 in. (609 mm) plus an additional 3 in. (76 mm) for each 1-ft. (305 mm) increased fence height over 4 ft. (1.22 m). In areas where frost is common, the footing shall extend a minimum of 6 in. (152.4 mm) below the maximum frost level.

Preparation of Post – To secure post vertically, provide a means such as, but not limited to, notching, drilling, roughing, pinning, etc.

Installation of Posts:

This practice includes three post-setting methods. Method 1 should be used where there are mucky or loose soil conditions.

Method 1 – Partially fill holes with concrete, then set the post into the concrete leaving approximately 2 to 4 in. (51 to 101 mm) of concrete below the bottom of the post (see FIG.1). Continue filling the hole with concrete to within 6 to 9 in. (152.4 to 228.6 mm) of the top. Fill the remainder of the hole with soil or fine rocks. Where frost is not likely, the hole may be filled to ground level with concrete (see Note1). The post shall extend a minimum of 18 in. (457.2 mm) into the concrete (see FIG. 2). Check to see that the post remains plum until the concrete has set.

Note 1 – Filling hole to top with concrete in frost areas will enhance upheaval of post and footers as concrete freezes faster than fill.

Method 2 – Tap the post into the bottom of the hole until the desired height of the post above ground level is reached (see Note 2 and FIG. 3). Add concrete around the post to the level specified in Method 1. Check to see the post remains plumb until the concrete has set.

Note 2 – This method should not be used where there are mucky or loose soil conditions as without concrete under the post, it may sink if downward pressure is applied.

Method 3 – Tap the post into the bottom of the hole until the desired height of the post above ground level is reached (see FIG.4). Fill the hole one fourth of the depth with concrete, then add fine rocks or gravel (see Note1). Check to see that the post remains plumb until the concrete has set.

Even if concrete is not used on line posts, it should be used on corner posts and gate posts (See "For extra fence post stability"). Your post will be best stabilized if the post hole provides room for a minimum of 2"-3.5" of firmly compacted dirt or concrete on all sides of the post.

For extra fence post stability,

the following suggestions should be considered:

- The option of a double-wall post versus a single-wall post.
- When longer (wider) gates are used, additional concrete should be placed around base of post.
- Remember, all sections should be in place before securing post with rebar and concrete (such as end posts, corner posts, or gate posts).

The following method of securing an end post, corner post or gate post will improve stability and prevent sagging gates.

Method 1 – Steps

1. **Dig Post Hole** (10" or 12" dia.)
NOTE: When using larger heavier gates, hole diameters should be kept at 12" or bigger.
2. **Drill holes near bottom of post, spaced approximately 4" from bottom, 6" apart. Place 1' lengths of 1/2" rebar in holes.** (Allow approximately equal amounts on each side of post).

3. **Set post and place concrete around post base.**
4. **Put sections together and fill post with concrete.**
NOTE: Cover ends of rails or section rails with duct tape to prevent concrete seepage into rails.
5. **Push rebar down through wet concrete inside of post. (5" x 5" post, 2 lengths of 1/2" rebar; 4" x 4" and 3 1/2" x 3 1/2" post, 1 length of 1/2" rebar)** NOTE: Rebar should be as long as post.
6. **Mount all hardware and/or place brackets on post while concrete is wet.** NOTE: By doing this step last, will help prevent air pockets in concrete around screws and rebar.

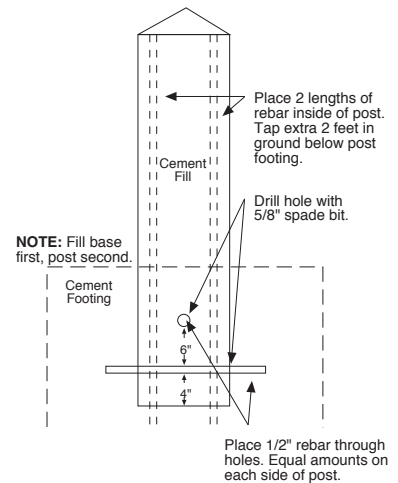

Method 2 – Country Estate Fence carried aluminum post inserts that greatly assist in post stability, also by using aluminum post inserts there is less time needed for concrete to set as it is only at the base of the post. This really helps reduce installation times generally as a rule by one day.

NOTE: Method 2 is recommended in areas where temperatures drop below freezing (32° F) and all other temperature climates.

Infill is the material placed around the post at and above ground level. Infill aids in water drainage and runoff. This is sometimes called crowning. Keeping water away from the posts aids in maintaining alignment.

IMPORTANT: The installation of the posts and the maintaining of their alignment is the most critical step in fence construction.

GATE POSTS

IMPORTANT: Country Estate rail gates and most other rail gates are available for gate openings of 4', 6', 8', 10', and 12'. For example: For a 4' gate, the space between the gate post and the latch post is 4'. To allow for the hardware, the gate itself is 4" less than the actual gate opening.

Your gate will not be better than the post on which it is hung. If the weight of the gate causes it to shift in the soil, it will appear that your gate is sagging and it may not open properly. To assure a trouble-free installation, the gate post must be extremely stable. It should be mounted in an extra amount of concrete. Fill the inside of the post with concrete reinforced with rebar, or aluminum post inserts are available for 3.5", 4", and 5" gate posts, rather than using concrete and rebar. If an aluminum post insert is used, extend it well below the concrete used to stabilize the post in the posthole. You may also wish to use these same installation procedures on your latch posts.

When hanging gates, CEF recommends the use of aluminum post insert inside the gate post as discussed above. As an alternative method, we have seen the use of a gate post which extends above the gate and a supporting cable is strung from the top of the gate post to the far end of the gate. You may have a rust problem with the cable system. **CAUTION:** The cable system should not be used where animals are present because it is possible for them to get their heads wedged in the angle created where the cable attaches to the top of the gate. **EXTREME CAUTION:** The cable system is also a hazard for small children who may play on the gate.

Remember: If your gate requires a bolt/screw through the post and/or latch or if the hardware screws into the gate and/or latch post, mount your hardware on the posts while the concrete is still wet. If you are using aluminum inserts this will not be necessary, but the pre-drilling of screw holes will be to help facilitate securing hardware.

TYPICAL FASTENING TECHNIQUES:

ROUTED POST / INSERTED RAIL:

Our most popular rail-mounting method. The central mounting makes the fence appear the same from either side. In this technique, the post is routed and the rail inserted. Twin notches are made on both sides of each rail, and as the illustration shows, the horizontals are easily inserted, but will not slip out after snapping into the post.

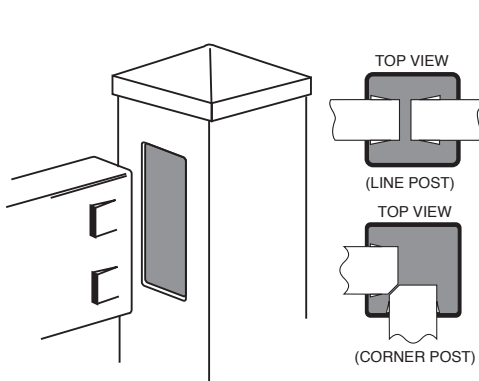

DOWEL ROD MOUNTED RAILS:

May be used in high traffic areas, corrals, runways, etc. In this technique 1/2" holes are drilled all the way through both ends of a top horizontal rail and after horizontal is inserted into routed hole a 1/2" dowel rod is inserted through the hole. The dowel rod is crimped at the top to prevent dropping through the hole.

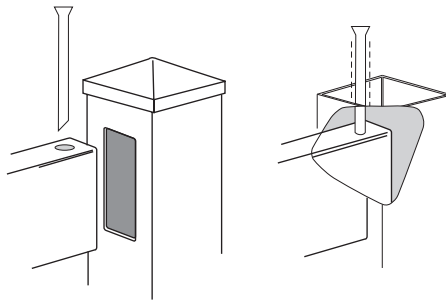

SIDE MOUNTED RAILS:

Some equine operations prefer this method of mounting to prevent injury to horses, should they collide with a post when "running the rail". The bracket simply attaches to the post, and the junction of the two rails occurs behind the bracket.

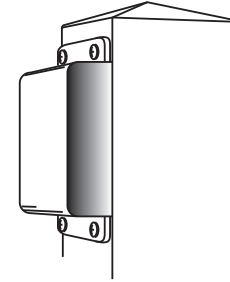

NOTE: Dowel rod is generally used only in the top horizontal at both ends of the horizontal for enhanced stability in high traffic areas. 1/2" Holes are drilled at both ends to accommodate insertion of dowel rod.

PLANNING AND INSTALLING GATES AND GATE HARDWARE

Give considerable thought to the convenient location and proper installation of your gates. They will be the most visible part of your fence project. If they are the wrong size or if they do not swing conveniently, they can become an annoyance rather than a convenience. The following considerations are provided to help you plan for the most appropriate gate size, location, and hardware.

- Will you need both walk-through and drive-through gates?
- Will your walk-through gates be used for wheel barrows, bicycles, lawn mowers, etc? If so, make certain your gate will open wide enough. If you plan to use the gate for a riding lawn mower, double check the mower's width.
- Gates for accessing automobiles must have a minimum opening of 8'. After the gate is mounted, the opening is reduced to less than 8'. If you will use the gate on a daily basis, you will want a 10' or 12' opening.
- If you have a high traffic area that requires a gate opening exceeding 8', consider covering the opening with double gates. In some ways, two five-foot gates are less handy than one large gate, but they are more trouble free. The use of two gates is particularly practical if the gates are most commonly left open. Two gates should be considered if swing space is limited.
- If you plan the use of a 10' gate, give special consideration to the stability of the gate post. See our Gate Post recommendations.
- Consider where your gates will swing when they are open. Will you need to hold them open? (cane bolt/latch)?
- You will need to decide which direction you want your gate to swing. The manner in which the hinges are mounted will determine the direction the gate will open.
- To the extent possible install gate at a flat location. This will greatly assist the installation, mounting and operation of your gate, allowing it to swing more freely as designed.

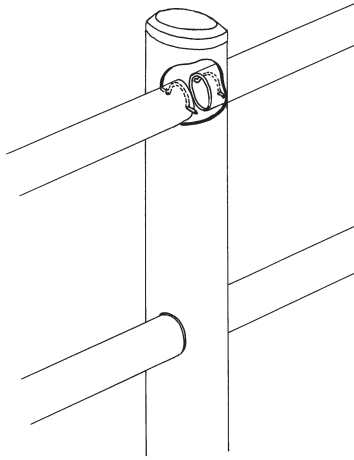

**ROUND ROUNDED POST/
INSERTED RAIL**
The round rail uses a heavy duty spring clip to secure the rail inside the post.

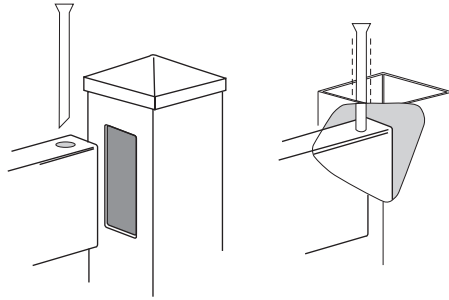

DOWEL ROD MOUNTED RAILS:
May be used in high traffic areas, corrals, runways, etc. In this technique 1/2" holes are drilled all the way through both ends of a top horizontal rail and after horizontal is inserted into routed hole a 1/2" dowel rod is inserted through the hole. The dowel rod is crimped at the top to prevent dropping through the hole.

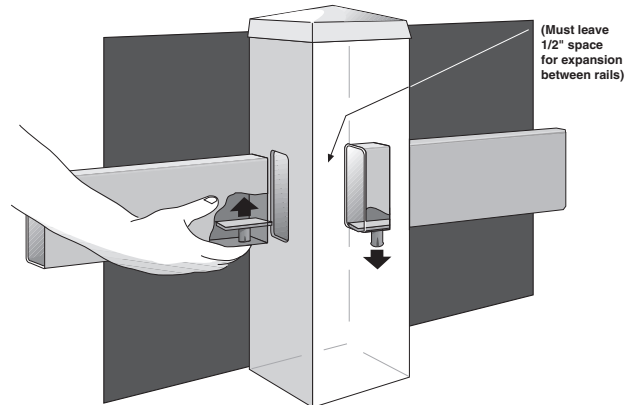

ROUTED POST/GRAVITY LOCK
This Country Estate Fence lock is used exclusively with the 2" x 6" or 1-1/2" x 5-1/2" horizontals. Its special design enhances ease of installation allowing rails to be secured but also can be removed without damaging horizontals.

INSTALLING RAIL FENCING USING BRACKETS

(1-1/2" x 5-1/2" RAILS OR 2" x 6" RAILS)

Steps

1. **Tools and Supplies.** You will need:
 1. A variable speed electric drill or a power driver with a No. 3 phillips drive.
 2. A post hole auger with a 10" or 12" bit.
 3. A tape measure longer than 16'.
 4. A string line and stakes. If available, use a spring-loaded cable with a hook on the end (See page 10). With spray paint, mark the cable at 8'-1/2" intervals.
 5. Carpenter's level.
 6. Large mallet and a piece of hard wood.
 7. A can of brightly colored spray paint.
 8. In frost areas you will want coarse gravel to fill the first several inches of each post hole.
 9. Either dry mix or wet concrete for stabilizing posts.
 10. PVC cement for attaching post caps and rail plugs.
2. **Setting the String Line or Spring-loaded Cable.** Set the string line (or spring-loaded cable) at the outer edge of the desired post location. Use the spray paint to mark each post location.
3. **Digging the Post Holes.** In frost areas, drill the post hole slightly deeper than the desired post depth. In frost-free and rock-free areas, drill the post holes slightly shallower than the desired post depth.
4. **Setting and Aligning Posts.** In frost areas, backfill the first several inches of the post hole with coarse gravel. In frost-free areas, set the post in the hole, place a block of wood on the top of the post and use the mallet to tap the post down to the desired height. Use your string line, carpenter's level, and tape measure to make certain that each post is set exactly on 8' 1/2" centers, that each post is exactly perpendicular, and that both the top and bottom of each post center is on exact 8' 1/2" centers. If you backfill with dry-mix concrete, tamp and pack the backfill tightly. If you backfill with wet concrete, use care not to slop the concrete on to the post (See pages 7 and 10). Make certain each post is the correct height.

5. **Attach Brackets to Rails.** If you use wet concrete, wait until the concrete has set up before attempting to mount brackets. Mount brackets on the inside (enclosure side) of the fence. Drill a starter hole for each screw. Attach the top of each bracket to the post. Mount the top bracket so that the top of the top rail is 2" below the top of the post. On two-rail and three-rail fences, space the rails 11" apart. On four-rail fences, space the rails 9" apart. If your installation includes gates, check the spacing of the rails on your gates so the spacing of the gate-rails and the spacing of the fence-rails will match.
6. **Mount Rails.** Put the rails in place. Stagger the 16' rails (See page 8). Install the bottom bracket screws. **IMPORTANT:** Make certain you allow the proper expansion gap between the rail ends (See page 6). **IMPORTANT:** Make certain the expansion gap occurs at the exact center of the post. **IMPORTANT:** Stabilize the center of each 16' rail by placing a screw through the bottom of each center bracket and into the center of the rail (See page 6).
7. **Install Caps and Rail Plugs.** On external caps, place a small bead of PVC cement on the inside of the cap lip. On internal caps, place a small bead of PVC cement on the inside of the post.
8. **Clean Fence.** During installation, your fence will have collected dirt and finger marks. These may be wiped off with "Soft Scrub" or a comparable product. Light solutions of bleach and water will work. Some professional installers wipe down the fence with rags lightly soaked with lacquer thinner. Lacquer thinner works very well, but use it sparingly.

Notes:

Standard finished fence brackets will permit the mounting of fence boards at up to a 10° angle from horizontal by placing the bracket on the post at an angle (See illustration A). The brackets will also permit up to a 10° offset on fence boards by placing the bracket angle between the offset and running each board into the bracket at a 5° angle (See illustration B).

For applications requiring an angle greater than 10°, unfinished bracket stock is available. It can be cut to any required angle on a radial arm saw or large miter box. For boards without an offset, the stock should be cut to the standard 4-1/2" bracket width on the required angle (See illustration C). For boards with an offset greater than 10°, two 2-1/4" width brackets must be used, each cut at the required angle (See illustration D).

When constructing large installations of bracketed fence, you may wish to mount the top of each bracket to the post before the post is set. Once the posts are set, pop the rails into the brackets and secure the bottom of the bracket. This method is not practical if the site rolls or has considerable slope.

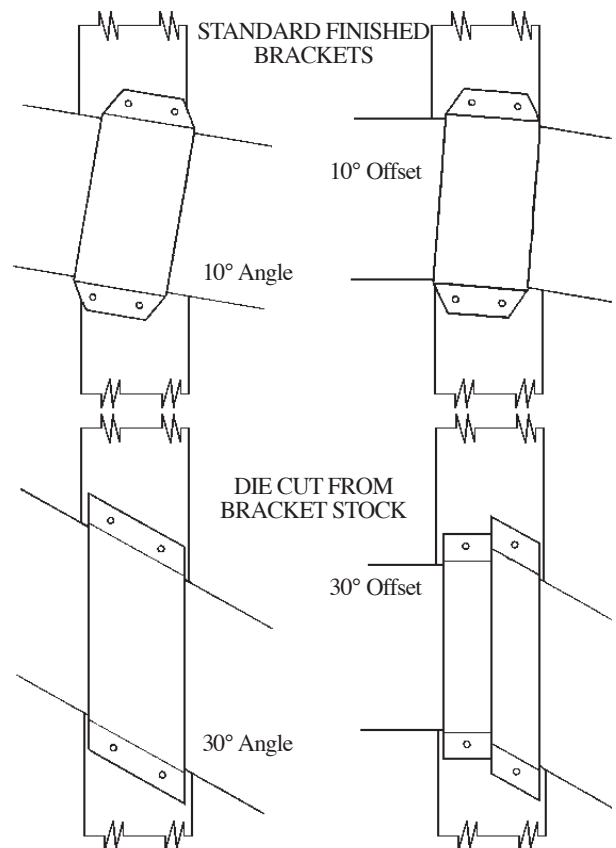

INSTALLING ROUTED POSTS WITH NOTCHED RAILS/RAIL LOCKS/ DOWEL RODS/SPRING CLIPS (Round Rail Only)

(1-1/2" x 5-1/2" NOTCHED RAILS/RAIL LOCKS/DOWEL RODS OR 2" x 6" NOTCHED RAILS/RAIL LOCKS/DOWEL RODS OR 3" ROUND RAILS/SPRING CLIPS)

Steps

- 1. Tools and Supplies.** You will need:
 1. A post hole auger with a 10" or 12" bit.
 2. A tape measure longer than 16'.
 3. A string line and stakes. If available, use a spring-loaded cable with a hook on the end (See page 10). With spray paint, mark the cable at 8'-1/2" intervals.
 4. Carpenter's level.
 5. Large mallet and a piece of hard wood.
 6. A can of brightly colored spray paint.
 7. In frost areas you will want coarse gravel to fill the first several inches of each post hole.
 8. Either dry mix or wet concrete for stabilizing posts.
 9. PVC cement for attaching post caps and rail plugs.
- 2. Setting the String Line or Spring-loaded Cable.** Set the string line (or spring-loaded cable) at the outer edge of the desired post location. Use the spray paint to mark each post location.
- 3. Digging the Post Holes.** In frost areas, drill the post hole slightly deeper than the desired post depth. In frost-free, set the post in the hole, place a block of wood on the top of the post, and use a mallet to tap the post down to the desired height. Use your string line, carpenter's level, and tape measure to make certain that each post is set exactly on 8'-1/2" center, that each post is exactly perpendicular, and that both the top and bottom of each post center is on exact 8'-1/2" centers. If you backfill with dry-mix concrete, tamp and pack the backfill tightly. If you backfill with wet concrete, use care not to slop the concrete on to the post (See pages 7 and 10). Make certain each post is the correct height.
- 4. Thread the Rails into the Routed Holes in the Posts.** Starting with the bottom rail, thread the 16' rail through the post that will be in the middle of that 16' rail. Snap the notches of the lead end of the rail into the starter post. Then snap the tail end of the rail into its post. You will have to bow the rail to snap in the tail end. **IMPORTANT:** To allow for expansion and contraction, make certain the notched end of the rail does not abut the far side of the starter post or against the end of an adjoining rail (See page 6). Stagger the rails (See page 8). To stagger the rails, you will need 8' starter rails. When 16' sections are cut to provide the need for shorter rails, the cut end must be notched with a special notching tool. If the notching tool is not available, you may create an effective restraint by putting one large headed stainless steel screw into the middle of each side of the rail's side wall. The screws should be 1" from the end of the rail. Drill starter holes for the screws. By squeezing the sides of the rail, insert the end through the notched hole. The heads of the screws will function as substitutes for the notches in the rail.

NOTE: Dowel rod is generally used only in the top horizontal at both ends of the horizontal for enhanced stability in high traffic areas. 1/2" Holes are drilled at both ends to accommodate insertion of dowel rod.

5. **Install Caps and Rail Plugs.** On external caps, place a small bead of PVC cement on the inside of the cap lip. On internal caps, place a small bead of PVC cement on the inside of the post.
6. **Clean Fence.** During installation, your fence will have collected dirt and finger marks. These may be wiped off with "Soft Scrub" or a comparable product. Light solutions of bleach and water will work. Some professional installers wipe down the fence with rags and lacquer thinner. Lacquer thinner works very well, but use it sparingly.

The photographs on pages 17 and 18 demonstrate how to thread notched rails through the routed holes. Notice that the rail fence in these photographs was not constructed for horses. Therefore the installers did not stagger the rails as recommended on page 8.

If you are constructing a routed fence on a curve, cut halfway through the 16' rails at the mid point. If properly done, the cut should be on the outside of the curve and it will allow the rail to "bend" around the curve. When the rail is threaded into the posts, the cut will be on the inside of the post.



Holes dug, posts aligned and initially tamped in dry cement, water is being added to set the posts.



Threading the first rails, starting at the bottom. If spacing permits, rails are staggered at the joints.



Country Estate rails utilize wedge locks that allow expansion without uncoupling, once pushed through the routed post opening.



Rails are threaded through the pre-routed posts.

Rails are added, working from the ground, upward.



Aligning the fully assembled fence before final tamping.

Once aligned, each post is tamped for fence rigidity.

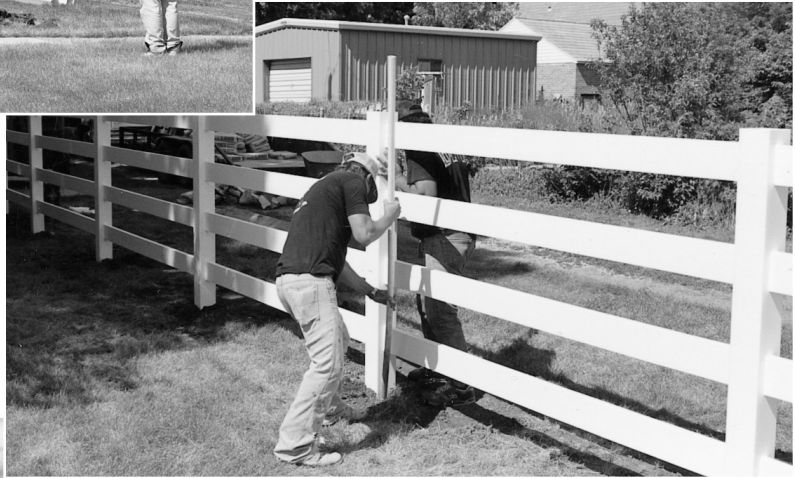

The last step—applying PVC cement or weatherable silicone sealant and mounting caps.

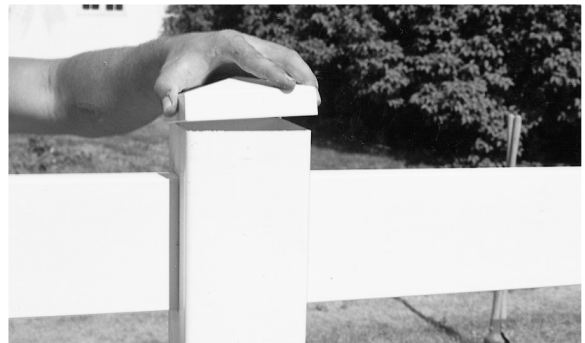

CAUTION

Failure to follow recommended installation procedures will result in loss of Manufacturer's Warranty. Alternate procedures or post spacing in excess of 8'-1/2" will require a Written Authorization from Nebraska Plastics, Inc., to retain warranty rights.

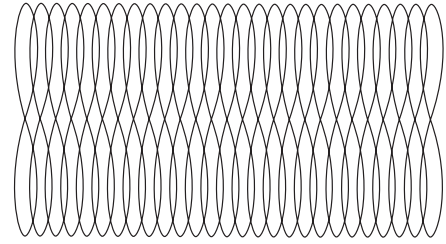
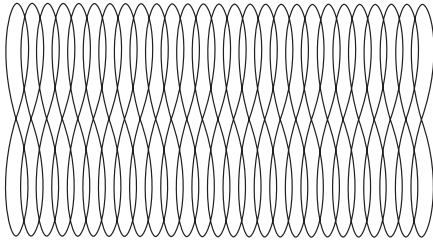

Nebraska Plastics, Inc., warrants that it will provide the original consumer purchaser of PVC Country Estate Fence, Deck, Railing and Country Manor Garden Accessories with products that are free from defective raw materials and manufacturing defects. As a result, these products will not peel, flake, rust, blister or corrode. Furthermore, Nebraska Plastics, Inc., warrants that these products will not require the painting and traditional maintenance normally associated with fencing manufactured from raw materials other than PVC, nor will they exhibit abnormal weathering, discoloration and brittleness, nor will they be damaged by insects.

What materials are covered by this warranty?

- All PVC products manufactured and sold as Country Estate Fence, Deck Railing and Country Manor Garden Accessories are covered by this 50-year warranty if the original consumer purchaser registers his/her warranty with Nebraska Plastics within 30 days of his/her purchase. Products sold by Nebraska Plastics, Inc., but not manufactured of PVC are not covered by this warranty.

What does this warranty cover?

- Product failure resulting from defective raw materials and/or manufacturing defects.

How long will the warranty be effective?

- For residential consumer purchases, the warranty shall be fully effective without proration for fifty years from the date of purchase or until the original consumer purchaser sells his property without effecting a properly executed warranty transfer or until the warranted materials are moved from their original location and/or altered from their original Country Estate approved designs. No combination of events will extend the warranty beyond fifty years from the original residential consumer's purchase.
- For commercial purchases, the warranty shall be effective without proration for twenty years from the date of purchase or until the original commercial property owner sells the property or until the warranted materials are moved from their original location and/or altered from their original Country Estate approved designs. Warranties on commercial purchase are not transferable.

Are registered Country Estate and Country Manor warranties transferable?

- Properly registered Country Estate and/or Country Manor warranties are eligible for a one-time transfer by the original residential consumer owner to a subsequent residential consumer purchaser of the real estate on which the warranted products were originally installed if:
 1. The warranty to be transferred was properly registered with Nebraska Plastics, Inc., within 30 days after the original purchase.
 2. The request for transfer is made within ten years of the original purchase.
 3. The product has not been moved from its original location and/or altered from its original Country Estate approved design or modified in any manner that compromises the product's original integrity.
 4. Nebraska Plastics, Inc., receives a written request for transfer within 30 days of the real estate transfer.
 5. Nebraska Plastics, Inc., receives proof of the original purchase and receives a copy of the original warranty that was signed by the Authorized Independent Country Estate Dealer/Installer establishing that the installation is 100% Country Estate products.
 6. Nebraska Plastics, Inc., receives a \$25 processing fee paid in full prior to the transfer.
 7. Warranties on commercial purchases are not transferable.

NOTICE: A TRANSFER OF THE WARRANTY WILL NOT EXTEND THE OVERALL WARRANTY PERIOD BEYOND 50 YEARS FROM THE ORIGINAL PURCHASE DATE.

What will Nebraska Plastics, Inc., do if problems develop?

- Nebraska Plastics, Inc., will furnish the registered owner of record with materials that are not defective.

How does the owner of record obtain warranty replacement materials?

- Contact the dealer who sold and/or installed the Country Estate Fence, Deck, Railing and/or Country Manor Products or write to Nebraska Plastics, Inc., P. O. Box 45, Cozad, Nebraska 69130 or call Nebraska Plastics, Inc. at 1-800-445-2887.

What is not covered by this warranty?

- Compensation other than being furnished replacement materials.
- Compensation for defective fabrication and/or installation work not performed by Nebraska Plastics, Inc., employees. The Authorized Independent Country Estate Installer must provide the warranty covering his/her fabrication and installation work. (On request, Nebraska Plastics, Inc., will provide the installer

and the consumer purchaser with installation manuals that describe recommended installation procedures or installation instructions and recommendations may be found at www.countryestate.com.)

- Compensation relating to projects where PVC materials manufactured by companies other than Nebraska Plastics, Inc., have been combined with Nebraska Plastics, Inc., PVC.
- Compensation for removing materials and/or mildew applied and/or accumulated on the products after the product was manufactured.
- Compensation for hardware or other non-PVC items replacement or removal.
- Compensation for damage due to misuse, vandalism, accidents or acts of God.
- Compensation for an insurable loss.
- Compensation for Country Estate Fence, Deck, Railing and/or Country Manor products that have been combined or incorporated into structures other than those manufactured by Nebraska Plastics, Inc., or that have been altered by the addition of paints and/or chemicals not recommended for use with Polyvinyl Chloride (PVC).
- Movement, distortion, collapse or settling of the ground or structure on which the fence, deck or railing is installed.
- Any other cause of failure not involving material and/or manufacturing defects in the product.
- Recoveries for consequential or incidental damages.
- Compensation for Country Estate Fence, Deck, Railing and/or Country Manor products for discoloration or other damage caused by air pollution (including but not limited to metal oxides or metallic particles), exposure to harmful chemicals or normal weathering from the elements.
- Compensation for normal and expected weathering. (Normal weathering shall be defined as exposure to ultra-violet light and extremes of weather and atmospheric conditions that will cause any colored surfaces to experience changes within the weather and color hold standards established in ASTM Specification D-4726.)

Other considerations limiting a purchaser's rights under this warranty:

- Nebraska Plastics shall have sole discretion to determine, based on reasonable criteria, whether the Country Estate Fence, Deck or Railing and/or Country Manor Products exhibit abnormal weathering. If the fence, deck or railing weathers to a degree determined by Nebraska Plastics to be beyond normal, Nebraska Plastics will, at its option, make repairs it deems appropriate or provide replacement material as it deems appropriate. Nebraska Plastics also reserves the right to refund the amount paid by the original owner for the Country Estate Fence, Deck or Railing and/or Country Manor Products materials and accessories.
- Nebraska Plastics retains the right to discontinue or modify any of its products, including the color, without notice to the homeowner/consumer, nor shall Nebraska Plastics be liable in the event the replacement material may vary in color or gloss in comparison to the original product as a result of normal weathering. If Nebraska Plastics replaces any material under this warranty, it may substitute products designated by Nebraska Plastics to be of comparable quality or price range in the event the product initially installed has been discontinued or modified.
- All disputes shall be governed by Nebraska law.

How does state law relate to this warranty?

- You may have rights other than those specified in this warranty. These rights vary from state to state.

How do you preserve your rights as a purchaser of Country Estate Products?

- On completion of your Country Estate project, your Authorized Independent Country Estate dealer should provide an official copy of the warranty that includes a registration card that must be signed by the Authorized Independent Country Estate Dealer/Installer and that card must be returned to Nebraska Plastics, Inc. If your dealer does not provide a copy of the warranty, call 1-800-445-2887.

Nebraska Plastics, Inc., will acknowledge receipt of your warranty registration.