



POSITIVE PRESSURE RELIEF DOOR MODEL BO

FUNCTION: To open outward to prevent damage to ductwork under excessive positive pressure.

CONSTRUCTION

- FRAME: 12 GA. galvanized steel.
- DOOR: 12 GA. galvanized steel.
- SEAL: 1/4" thick foam gasket.
- RANGE: Available factory preset for release pressure of 3" to 8" water gauge.
- SPRINGS: (2) Coiled return springs.
- INSTALLATION: Vertical only. Weld on or use high pressure sealing cement and screws or rivets.
- LATCH: Adjustable:
 - Factory set at the desired relief pressure.
 - Pressure must be given at time of order to properly size the latch.
 - Latch release setting can be fine-tuned in the field.
- INSULATION: Available as an option.
- WINDOW: Available as an option.

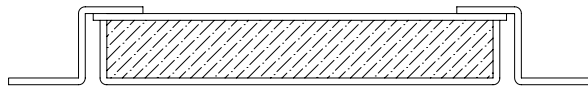

Optional 1" Double Wall Insulation

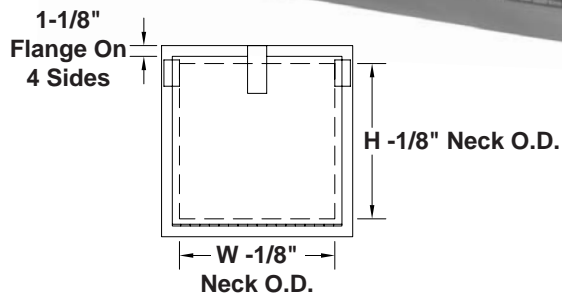

BO Latch

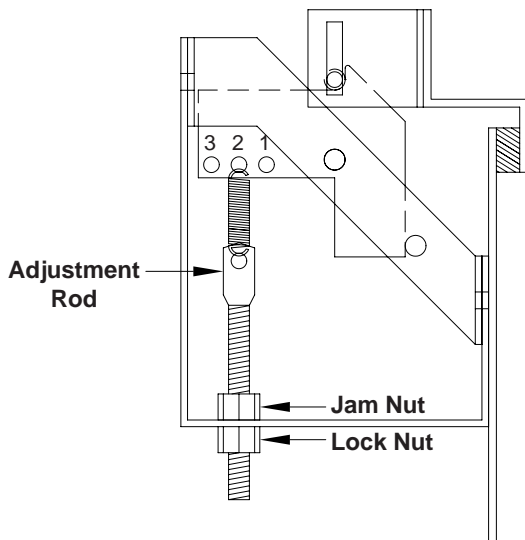

4 STANDARD SIZES
Other Sizes Available Upon Special Request

24 x 10	18 x 18
24 x 12	24 x 24

Qty.	Size		Relief Pressure In. Water Gauge	Options
	W	H		

FOR PERFORMANCE AND SELECTION INFORMATION, REFER TO FORM "BO/BI PERFORMANCE".

To maintain KEES' policy of continuous product improvement, we reserve the right to change prices, specifications, ratings or dimensions without notice or obligation.

Project			Location			
Engineer			KEES INCORPORATED 400 S. Industrial Dr. • P.O. Box L Elkhart Lake, WI 53020 Phone: (920) 876-3391 Fax: (920) 876-3065 Website: www.kees.com			
Architect		Dwg. No.				SD-BO
Contractor		Date				08/08



NEGATIVE PRESSURE RELIEF DOOR MODEL BI

FUNCTION: To open inward to prevent collapsing of ductwork under excessive negative pressure.

CONSTRUCTION

- FRAME: 12 GA. galvanized steel.
- DOOR: 12 GA. galvanized steel.
- SEAL: 1/4" thick foam gasket.
- RANGE: Available factory preset for release pressure of 3" to 8" water gauge.
- SPRINGS: (2) Coiled return springs.
- INSTALLATION: Vertical only. Weld on or use high pressure sealing cement and screws or rivets.
- LATCH: Adjustable:
 - Factory set at the desired relief pressure.
 - Pressure must be given at time of order to properly size the latch.
 - Latch release setting can be fine-tuned in the field.
- INSULATION: Available as an option.
- WINDOW: Available as an option.

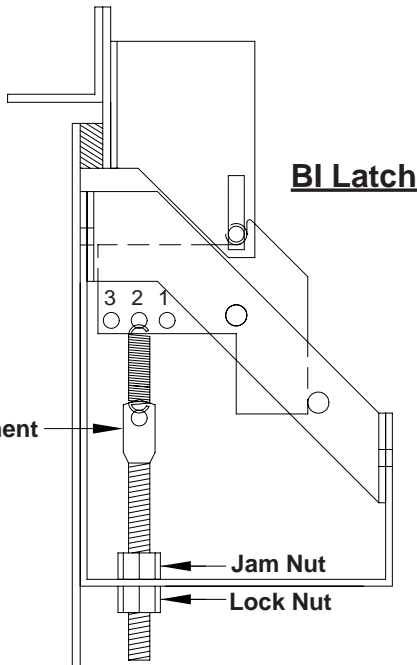
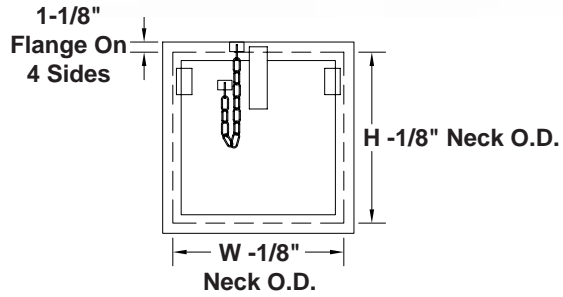
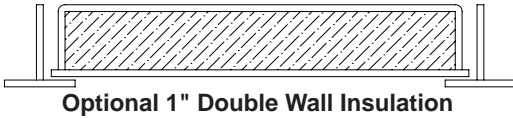
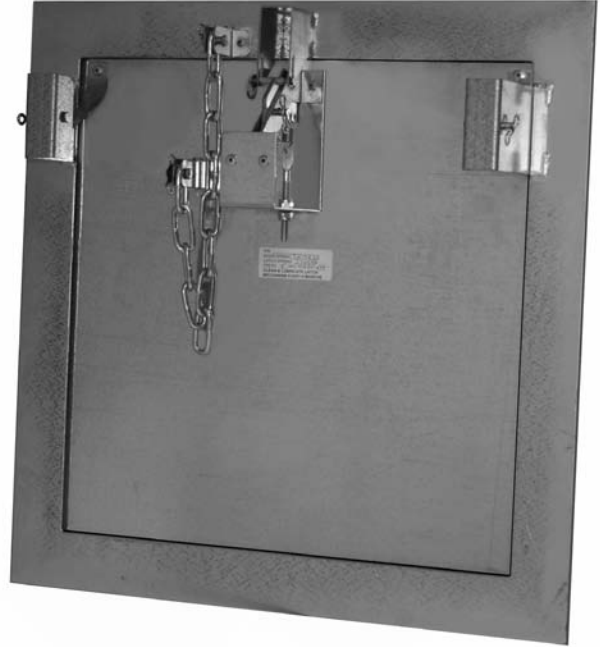

4 STANDARD SIZES
Other Sizes Available Upon Special Request

24 x 10	18 x 18
24 x 12	24 x 24

Qty.	Size		Relief Pressure In. Water Gauge	Options
	W	H		

FOR PERFORMANCE AND SELECTION INFORMATION, REFER TO FORM "BO/BI PERFORMANCE".

To maintain KEES' policy of continuous product improvement, we reserve the right to change prices, specifications, ratings or dimensions without notice or obligation.

Project				Location		
Engineer						KEES INCORPORATED 400 S. Industrial Dr. • P.O. Box L Elkhart Lake, WI 53020 Phone: (920) 876-3391 Fax: (920) 876-3065 Website: www.kees.com
Architect			Dwg. No.	SD-BI		
Contractor			Date	08/08		



MODELS BI / BO

PRESSURE RELIEF DOORS PERFORMANCE / SELECTION

MODEL BO - POSITIVE PRESSURE DUCT
 MODEL BI - NEGATIVE PRESSURE DUCT

FIG. A
 Fan Curve

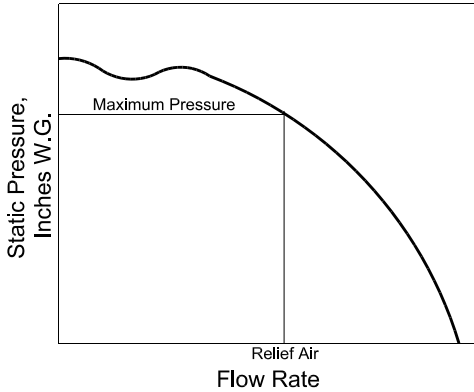
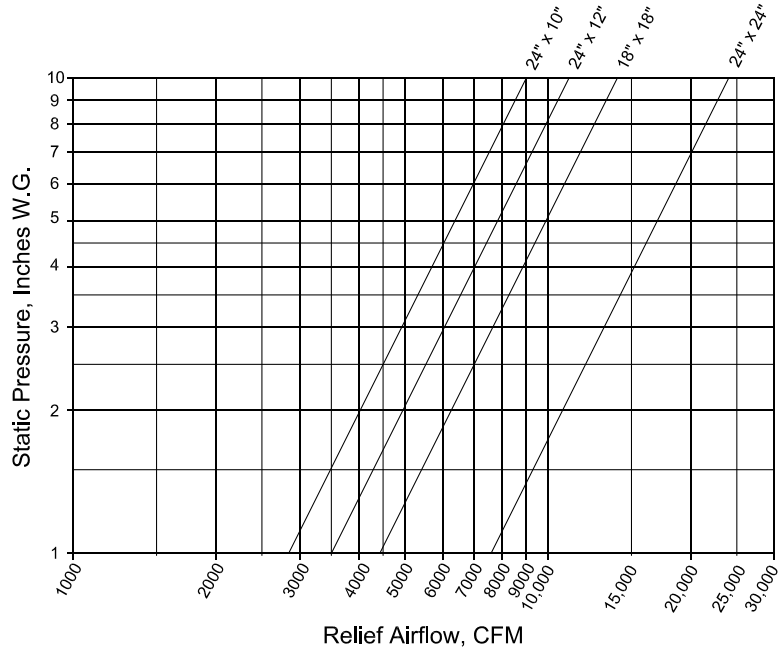

FIG. B
 Relief Airflow vs. Static Pressure



Selection

1. Referencing the system fan curve, determine the maximum duct pressure allowed and read the system volume at this pressure (FIG. A). This quantity (CFM) of air is the relief air required at this pressure. Alternately, if fan data is not available, use approximately 75% of the total duct airflow volume.
2. For the relief air quantity found in step 1 and referring to FIG. B, determine the relief air capacity of each door size at the maximum allowable duct pressure.
3. Select the appropriate quantity and size of doors that cumulatively total or exceed the relief air required.
4. When ordering or specifying KEES Model BI or BO doors, indicate the static pressure set point between 3" to 8". Reduce the relief pressure setting by approximately 20% for safety. The setpoint should be chosen near the maximum ductwork design pressure and at least 1" above the system's normal operating pressure. Pressure settings are factory set, but may be field adjusted.

Leakage Rates

FIG. C shows the amount of door air leakage vs. duct static pressure.

FIG. C
 Door Leakage Rate vs. Static Pressure

