

STAINLESS STEEL REGISTERS AND GRILLES

304 (Standard) or 316 (Optional) Stainless - Satin Finish

20 GA. Frame, 24 GA. Blades

Maximum single piece size for double deflection grille is 48" x 48".
 Maximum single piece size for single deflection grille is 60" x 48" or 48" x 60".
 See reverse side for butting details on multiple piece grilles.

SUPPLY

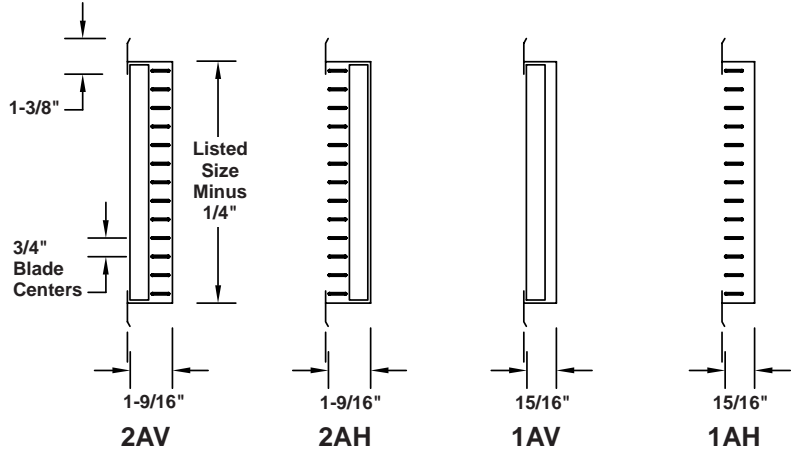
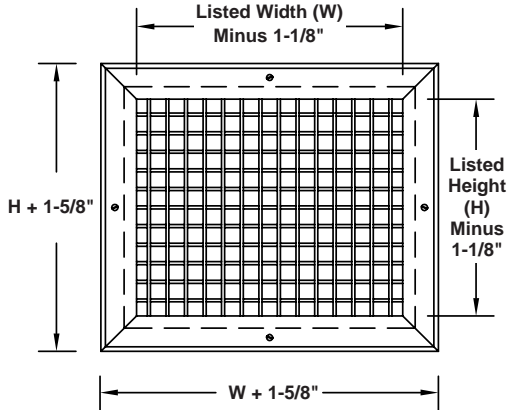

RETURN

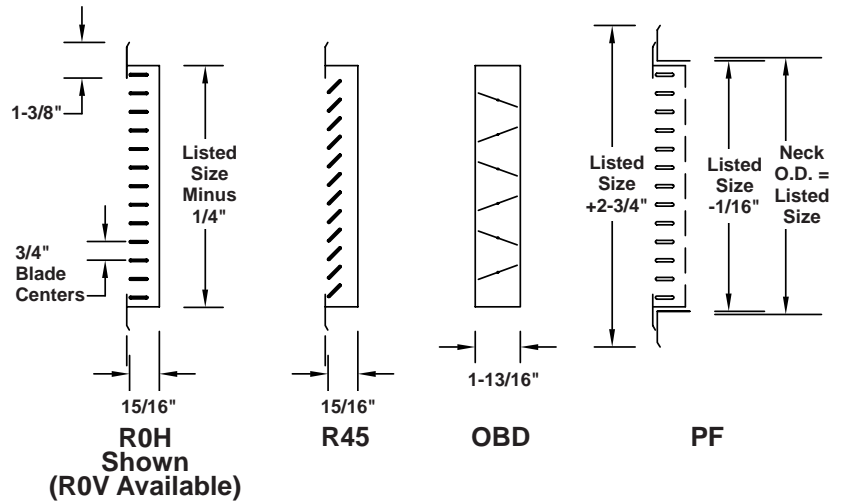
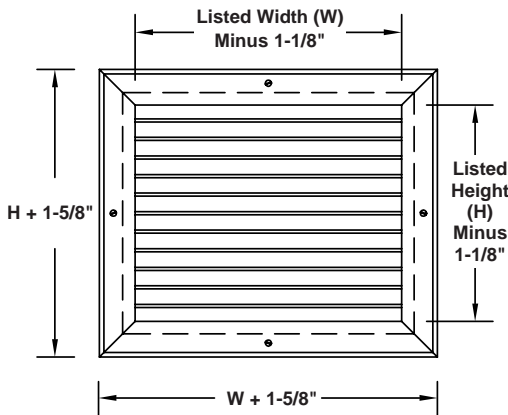

BLADE DETAIL



Quantity	Model	W	H	Type S.S.		Accessories	Tag
				304	316		

To maintain KEES' policy of continuous product improvement, we reserve the right to change prices, specifications, ratings or dimensions without notice or obligation.

Project				Location				
Engineer				 KEES INCORPORATED 400 S. Industrial Dr. • P.O. Box L Elkhart Lake, WI 53020 Phone: (920) 876-3391 Fax: (920) 876-3065 Website: www.kees.com				
Architect			Dwg. No.					SD-SS
Contractor			Date					08/09

STAINLESS STEEL REGISTERS AND GRILLES

304 (Standard) or 316 (Optional) Stainless - Satin Finish

20 GA. Frame, 24 GA. Blades

Maximum single piece size for double deflection grille is 48" x 48".

Maximum single piece size for single deflection grille is 60" x 48" or 48" x 60".

Larger order sizes will be made in multiple individual sections to fit opening size.

Mullion supports within opening to be provided by others.

BUTTING DETAIL

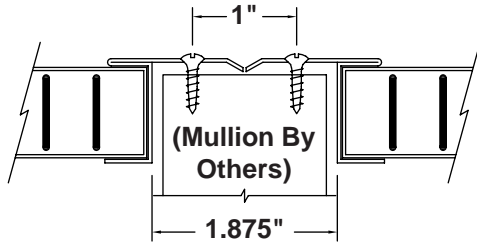

DOUBLE DEFLECTION

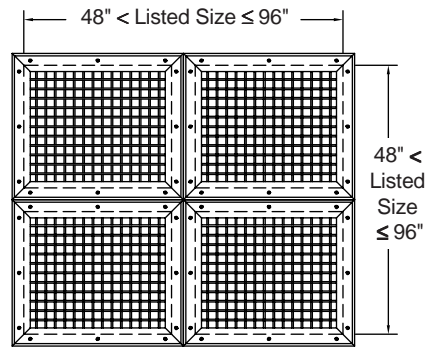
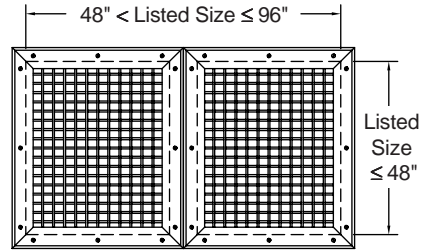

SINGLE DEFLECTION *

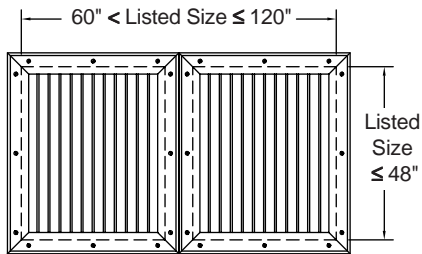

OR

SINGLE DEFLECTION *

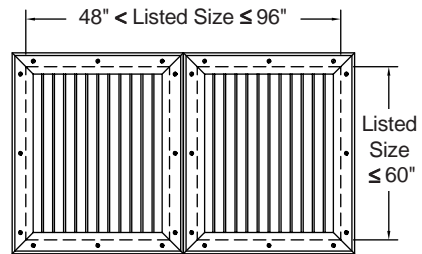

OR

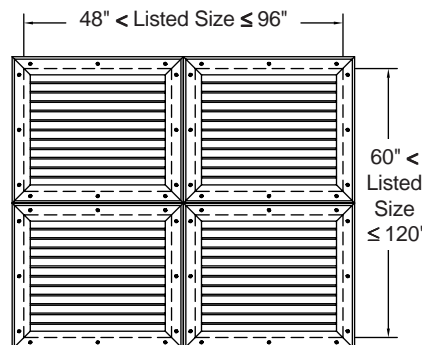
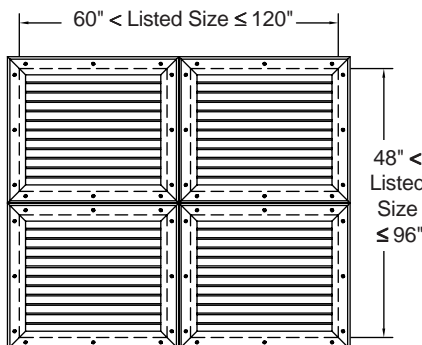

* Blades can be either vertical or horizontal for the dimensions shown.

To maintain KEES' policy of continuous product improvement, we reserve the right to change prices, specifications, ratings or dimensions without notice or obligation.

Project		Location		
Engineer			 KEES INCORPORATED 400 S. Industrial Dr. • P.O. Box L Elkhart Lake, WI 53020 Phone: (920) 876-3391 Fax: (920) 876-3065 Website: www.kees.com	
Architect		Dwg. No.		SD-SS
Contractor		Date		08/09