



**FLOOD BARRIERS  
FLOOD GATES  
WATERTIGHT DOORS & HATCHES  
AIRTIGHT & SECURITY DOORS**

America's Leader in Protective Door Systems

Thousands of Presray installations protect hospitals, schools, nuclear power plants, government labs, Fortune 500 headquarters, and defense installations around the globe. All doors and hatches are uniquely engineered to exact specifications ensuring a solid, tight fit. Presray offers both pneumatically sealed and compression gasket doors that make an ideal combination of security, accessibility, and value.

## FastLogs™ Stackable Flood Barrier System

- Easy to install, quick to deploy modular flood barriers.
- Modular construction equals affordable cost.
- Thoroughly tested in both Presray lab and in real world field conditions.
- All components are made from heavy-duty, rust-free materials for optimal performance in wet coastal areas.
- Ingenious, patented interlocking design allows for rapid deployment by one person with no tools.
- Will not degrade building aesthetics.
- Logs can be easily stored remotely or out of sight.



## FB33 Expandable Flood Barrier

- Patented hand-crank expandable steel frame.
- Ideal replacement for sandbag applications. Connector mullions link multiple panels together.
- Economical and easy to use.
- Lightweight—one person can deploy.
- Combination compression/lip seal around perimeter.
- Drop in place and deploys securely in opening in under 3 minutes.
- Designed for entry doors, garage doors, and openings requiring rapid, easy to install protection where very low leakage is acceptable.



## CGSL

### Gasketed Stop Log

for special purpose deep water applications as compared to FastLogs™



## FB11/22

### Lightweight Liftout Flood Barrier

with inflatable seal



## CG11FS

### Bolt In Place Liftout Flood Barrier

with compression seal



## CG22

### Bolt in Place Windows/ Louver Protection

with compression seal



## FB44

### Side Hinged Flood Gate with Flush Threshold

with inflatable seal



## CG11HA

### Side Hinged Flood Gate

with compression seal



## CG3S

### Sliding Flood Gate with Concealment Pocket

with compression or inflatable seal



## FB55

### Bottom Hinged "Flip-Up" Flood Gate

with inflatable seal



## FB77

### Hinged Watertight Door with Flush Threshold

with inflatable seal



## D3C/D3DQA

### Quick Acting Submarine Style Watertight Door

with compression seal

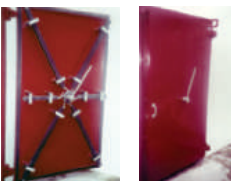

## D5B

### Sliding Watertight Door

with inflatable seal



## D3HA

### Watertight Hatch

with compression seal

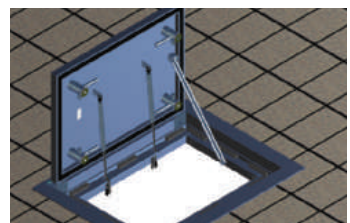

**Bio4-X**

**Airtight Door Pneumatic seal for accessibility**

- Configurable for BSL 4, BSL 3AG, and BSL 3.
- Flush threshold ideal for wheeled traffic and pedestrian flow.
- Ideally suited for bio-hazard labs, pharmaceutical and industrial clean rooms, gastight enclosures and other controlled areas.
- Single pneumatic seal provides airtight protection (double seal available for critical applications requiring redundancy).
- Electronic vestibule control synchronizing seals and electromagnetic locks available.
- Can be fabricated as impact resistant from either side.

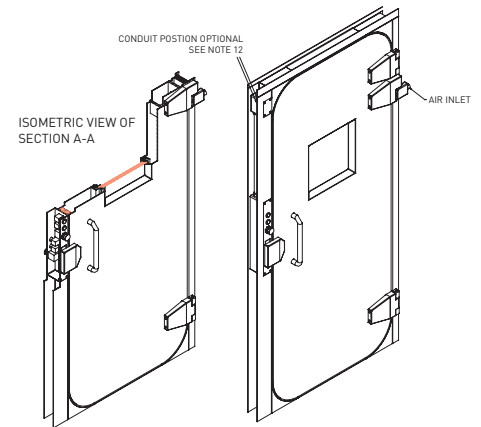

**Note:** These doors are available in several configurations; these pictures may not accurately resemble final product.

**D4BQA**

**Airtight Door Compression seal for simplicity**

- Configurable for BSL 4, BSL 3AG, and BSL 3.
- Highly engineered latching system provides for smooth, one-handed operation.
- Ideally suited for bio-hazard labs, pharmaceutical and industrial clean rooms, gastight enclosures, water treatment and other controlled areas.
- 2" floor sill/stepover required.
- Can be fabricated as impact resistant from either side.

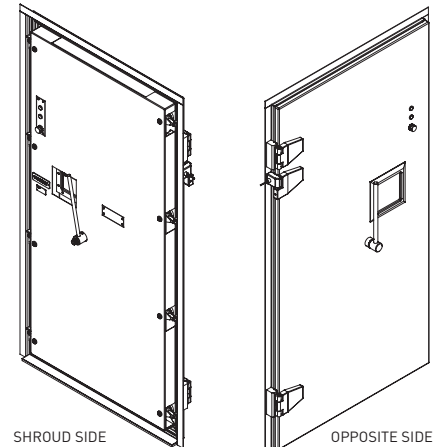
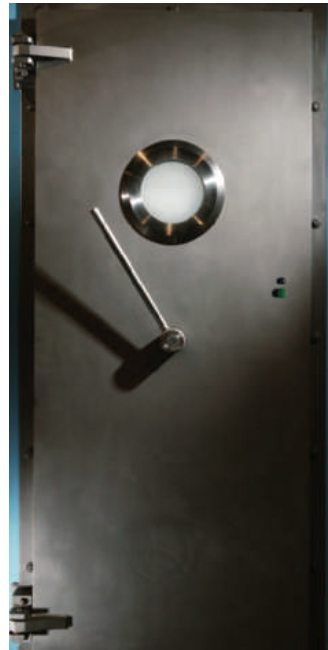

**Note:** These doors are available in several configurations; these pictures may not accurately resemble final product.

Presray Corporation  
 P.O. Box 200  
 32 Nelson Hill Rd.  
 Wassauc, NY 12592

phone 800-431-3456  
 845-373-9300  
 fax 845-855-8034  
 e-mail info@presray.com