

13 40 00.11/CRE  
BuyLine 7025

# 2008 CATALOG

Bullet Resistant Equipment



## Package Receiver

Package Receiver accommodates larger items for transfer. It has an inter-locking mechanism to allow only one door at a time to open. Front door can be locked from rear side with special locking bar. Closer is furnished on front door.

Package Receiver mounts into wall up to 11.5" thick. Adjustable frame on interior side mounts against wall in field. Exterior flange has rain cap along top edge.

### Finish options:

- Stainless steel door with prime painted housing
- Prime painted doors and housing

### Wall opening size:

15.5" wide x 15.5" high

### Clear inside dimension:

14.75" wide x 13.125" high x 15.5" deep

Level I or III bullet resistant

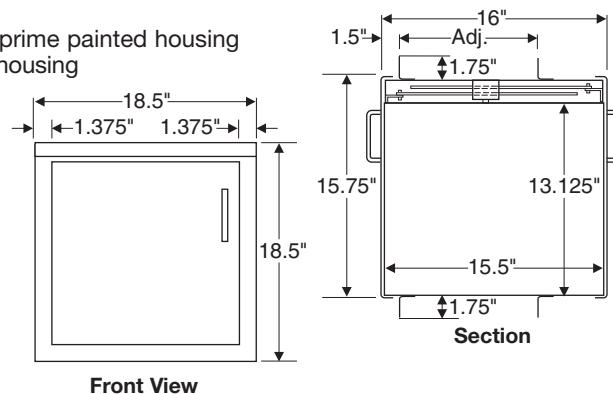

## Package Receiver with Vision Panel PR-VP

It is the same as standard Package Receiver above except vision panel in rear door enables operator to see contents inside unit.

### Construction:

Prime painted steel housing and stainless steel door

### Vision panel:

- Level I—1.25" acrylic
- or Level III—1.25" Lexgard

### Clear inside dimension:

14.375" wide x 13.125" high x 14.1875" deep

### Wall opening size:

15.5" wide x 15.5" high

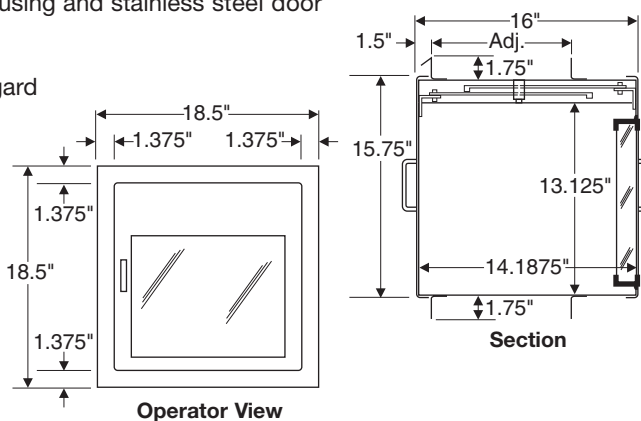

## Clear Package Receiver

Clear Package Receiver is for interior use only. Clear acrylic housing is fastened together with special aluminum extrusions. Clear acrylic doors allow plain view of contents. Bottom is made of plastic laminated plywood and bullet resistant fiberglass. Unit mounts on counter top. Special interlocking mechanism allows only one door at a time to open.

### Clear inside dimension:

13.3025" wide x 12.5" high x 13.375" deep

Level I or III bullet resistant

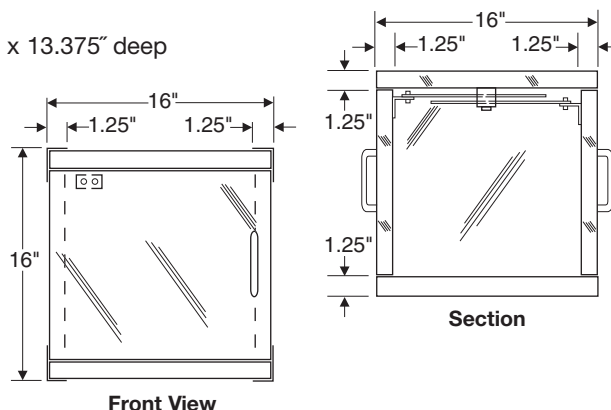



## Swivel-Thru No. 1 Combination Pass Thru and Deal Tray Patented

Stainless steel Swivel-Thru sets in transaction area of counter, centered beneath the bullet resistant window. For normal currency transactions the deal tray (lid) is locked in horizontal position by a turn latch incorporated in the knob. For larger items the deal tray is tilted upward to the lower edge of window to uncover the open drum below. After larger item is placed in open drum, deal tray is rotated in opposite direction by operator for access to drum contents. The Swivel-Thru is bullet resistant in all positions. It has the appearance of an ordinary deal tray when mounted in place, not detracting from aesthetics of counter. Unit is large enough to accommodate items such as an eight pack of drinks or large bag of coins.

### Construction:

Stainless steel

### Overall Size:

16" wide x 18" deep x 10" high

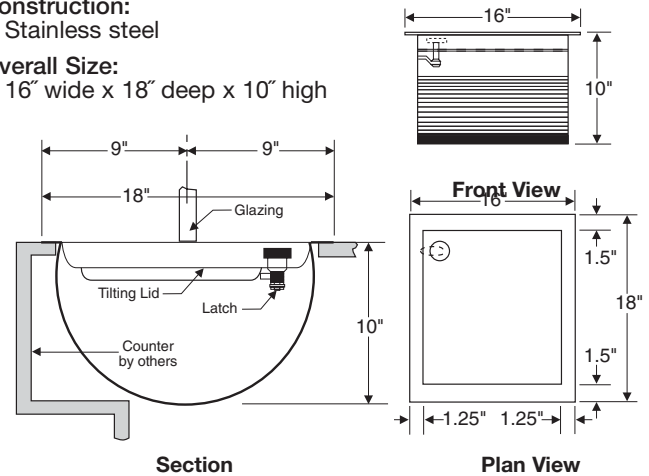

## Safti Server Patented

For drive-up or walk-up service, Safti Server provides bullet resistant protection while holding energy loss to a minimum. It allows no direct entry of outside air into the building.

Safti Server has only one moving part (the shelf) which turns both inward and outward to allow access to contents. Shelf extends approximately 15" from face of building when turned to customer.

Safti Server locks with the two adjacent acrylic doors forming an insulated barrier between outside and inside air. Unit mounts on window ledge, in wall opening or on counter top.

It has clear inside height of 14.5". Top, bottom and shelf are bullet resistant plastic. Sides are clear or dark bronze anodized aluminum. Doors are clear 1.25" thick acrylic.

### Construction:

Doors: 1.25" acrylic

Top, bottom and shelf: bullet resistant plastic

Sides: clear or dark bronze anodized aluminum

Level I bullet resistant

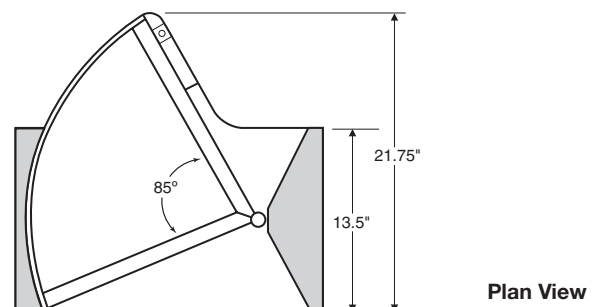
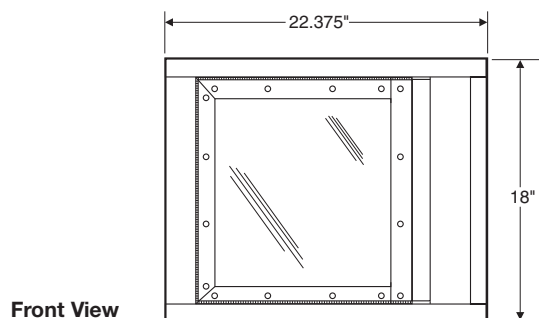

# Pass Thrus



## Pass Hopper with Flange

All stainless steel Pass Hopper mounts on counter top, in wall or window opening. Hopper pivots outward for customer access, then in opposite direction for operator access. Only one moving part allows virtually maintenance free service. Pass Hopper is equipped with weatherstrip for exterior use. Standard models provide Level I bullet resistant protection. Level III protection is an extra option.

Pass Hopper is available with stationary exterior flange and loose adjustable flange for rear side on all models.

**Construction:**  
stainless steel

Level I or III bullet resistant

## Pass Hopper PHE-1

Pass Hopper can handle a gallon of antifreeze, two liter beverage or bag of coins. Hopper locks with latch.

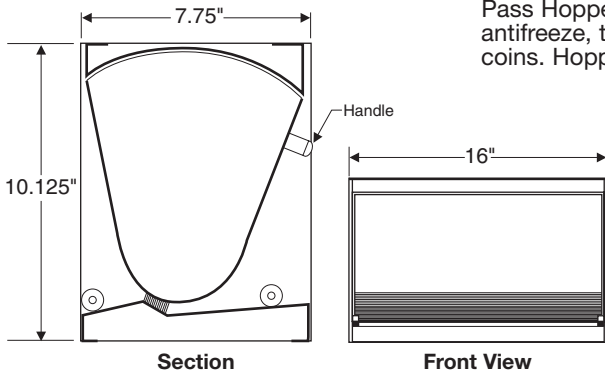

## Pass Hopper PHE-2

Largest pass Hopper provides ample capacity for larger bulky items. Equipped with stainless steel handle and round turn latch.

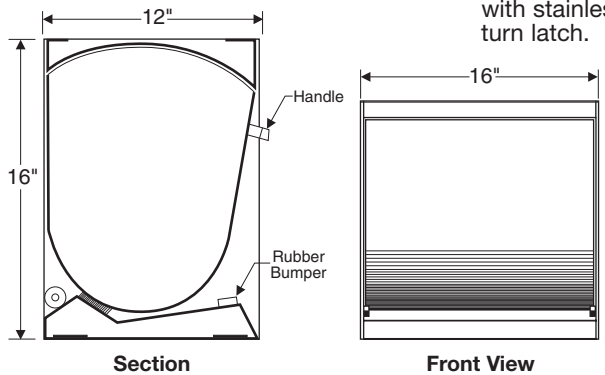

## Pass Hopper PHE-3

Pass Hopper can accommodate a three liter beverage or gallon of milk.

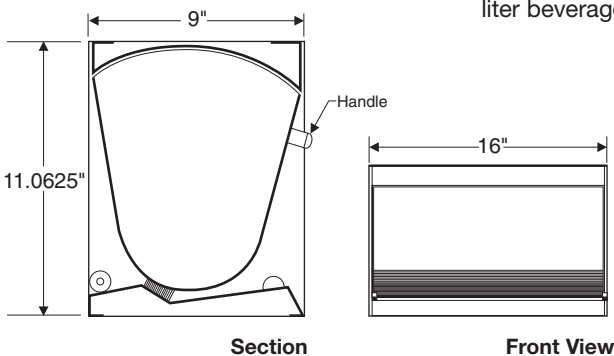

# Pass Thrus

## Exterior Lazy Susan LSW-CR

Exterior Lazy Susan is equipped with weatherstrip for outdoor use eliminating direct entry of outside air into the building. This unit has stainless steel sides and inner drum with a clear acrylic window for viewing contents. Top and bottom are bullet resistant plastic. Only one moving part, the inner drum, rotates with smooth movement. Crank handle on top turns the drum 180 degrees. Lazy Susan locks with a drop bolt. In locked position the stainless steel drum is turned to customer for maximum security. Unit mounts on counter top or in wall opening.

**Construction:**

- Stainless steel sides and inner drum
- Clear acrylic window

Level I bullet resistant

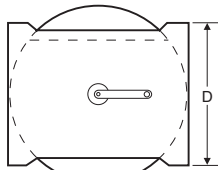

Plan View

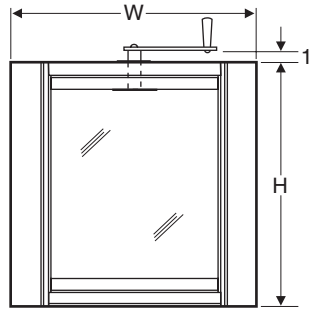

Front View



| Model       | Width | Height | Depth   |
|-------------|-------|--------|---------|
| LSW-CR 1512 | 15"   | 12"    | 11.625" |
| LSW-CR 1820 | 18"   | 20"    | 13.875" |
| LSW-CR 2418 | 24"   | 18"    | 18"     |
| LSW-CR 2618 | 26"   | 18"    | 19.625" |

# Drawers

## Transaction Drawer 1724-SCL Patented

Patented Transaction Drawer 1724-SCL has its lid and front door synchronized to open and close with no chance of lid being left open when drawer is extended. As drawer closes, the lid returns to slanted position allowing operator access to contents.

**Construction:**

- Drawer: bullet resistant plastic

**Housing:**

- .75" exterior plywood with stainless steel on exposed surfaces

**Face, hood, lid, handle and coin scoop:**

- Stainless steel

**Drawer extension:**

- 14.25"

**Wall opening size:**

- 17.5" wide x 11.5" high

Level I bullet resistant

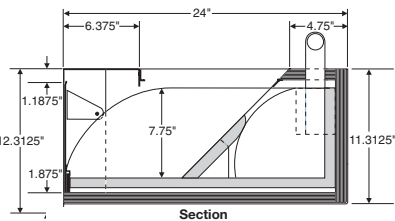

Section

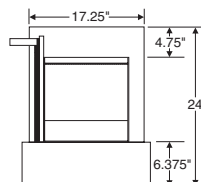

Plan View

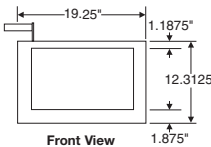

Front View

## Transaction Drawer 1724-SS

Transaction Drawer 1724-SS is suited for drive-up and walk-up service. This drawer is weather resistant. Lexan lid allows clear view of contents while preventing direct entry of outside air. Push button latch keeps lid locked when closed.

As drawer moves outward the stainless steel front panel pivots upward and inward. Drawer locks with drop bolt. Coin scoop and bill clip are included.

**Construction:**

- Drawer: bullet resistant plastic

**Housing:**

- .75" exterior plywood with stainless steel on exposed surfaces

**Face, hood, lid, handle and coin scoop:**

- Stainless steel

**Drawer extension:**

- 15"

**Wall opening size:**

- 17.5" wide x 10" high

**Drawer inside dimension:**

- 13" wide x 22" deep x 6.5" high

Level I bullet resistant

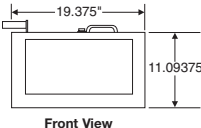

Front View

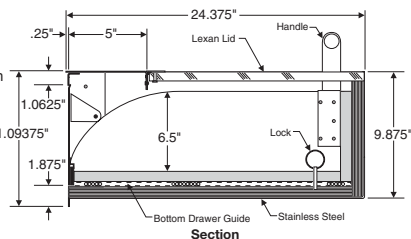

Section

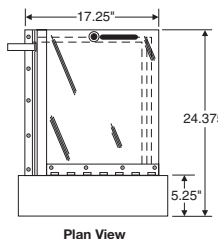

Plan View

## Deal Drawers

Deal Drawer recesses in counter top along front to achieve flush appearance. Glazing (by others) sets above the flat hood portion of drawer. Full width handle across rear of drawer along with smooth solid bearing slides allows easy operation. Lexan lid stays closed when drawer is extended.

**Construction:**

- Stainless steel

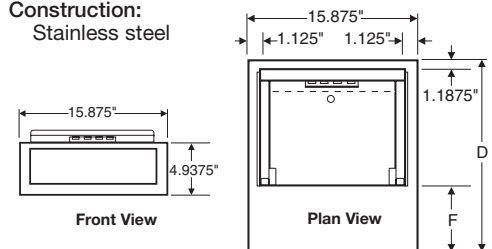

Front View

Plan View

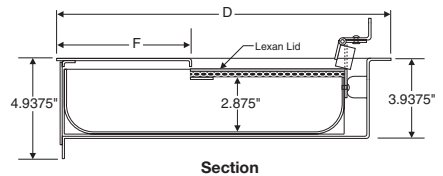

Section



| MODEL | F    | D      | W     | D   | H  |
|-------|------|--------|-------|-----|----|
| 1616  | 6.5" | 16.25" | 14.5" | 15" | 4" |
| 1620  | 6.5" | 20.25" | 14.5" | 19" | 4" |
| 1622  | 8"   | 22.25" | 14.5" | 21" | 4" |

# Deal Trays



**Self Closing Deal Tray SC**  
(patent pending)



**Recessed Deal Tray with Sliding Lid RSL 1414**



**Sliding Lid Model Deal Tray 1214-SL**

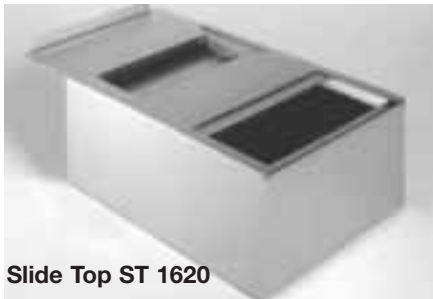

**Slide Top ST 1620**



**Recessed Deal Tray with Flip Lid FLR 1416**

# Drawers

## Cash Drawer 1618

Cash Drawer has stainless steel housing with bullet resistant plastic drawer. Unit mounts in counter top along front edge. Glazing (by others) should set above the flat hood portion of drawer. As drawer slides out the stainless steel front panel pivots upward. Movement is controlled by the full width handle across rear of drawer. Lexan lid stays closed when drawer is extended. This unit is designed for long life as there are no slides to wear out.

**Construction:**  
Housing: stainless steel  
Drawer: bullet resistant plastic

**Counter top opening size:**  
14.5" wide x 17.125" deep x 5.75" high

**Drawer extension:**  
9"

**Inside dimension of drawer:**  
12" wide x 14.625" deep x 3.625" high

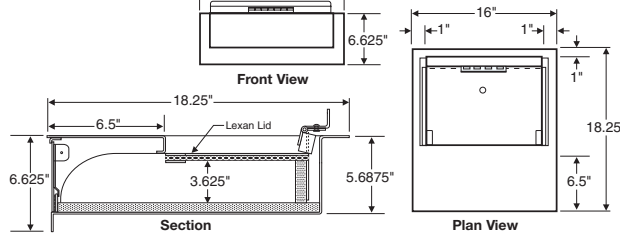

## Transaction Drawer 1924-DD

1924-DD Transaction Drawer is bullet resistant and weather resistant. It is well suited for drive-up service. Drawer moves on heavy duty ball bearing slides and the front doors open as drawer is extended. The drawer locks automatically when closed. Lexan lid permits clear view inside drawer and remains closed when drawer is open to customer. Bill clip and coin pad are furnished inside drawer to hold currency. Drawer can be mounted in wall 1.0625" up to 8.625" thick.

**Construction:**  
Drawer and housing: bullet resistant plastic  
Doors, hood and flange: stainless steel

**Inside drawer dimensions:**  
14.5" wide x 20" deep x 12" high

**Drawer extension:**  
15.5"

**Wall opening size:**  
19.25" wide x 16.5" high

Level I bullet resistant

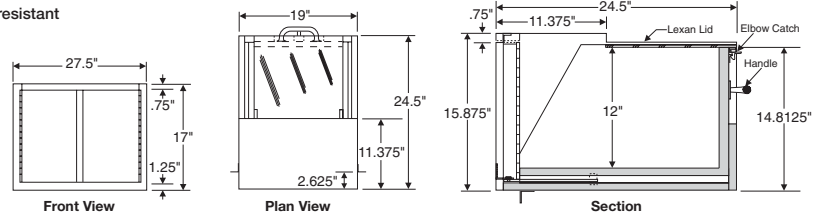

## Counter Top with Drawer Patented

Stainless steel counter top with built-in drawer (patented) is ideal for stadiums, motels, banks or gas stations. Ample space is provided on top for writing surface. Drawer moves quietly on solid bearing slides and blends smoothly into front of counter top when closed. Drawer locks via turn latch in handle. Unit is weatherstripped to hold energy loss to a minimum.

**Construction:**  
Stainless steel

**Inside drawer dimensions:**  
11.875" wide x 16" deep x 2.0625" high.

Level I bullet resistant

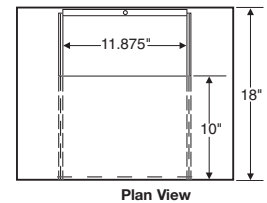
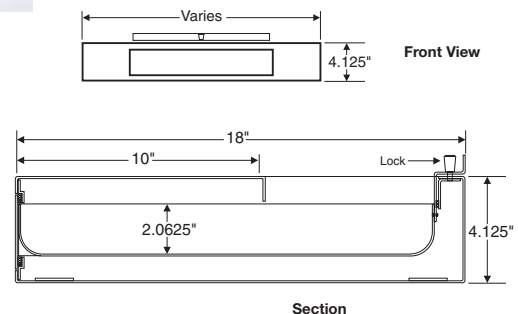



### 1724-WW and 1728-WW Transaction Drawers

WW Series Transaction Drawers are designed with exterior walk-up service in mind. It has an extra deep stainless steel hood which enables it to fit thicker walls. The Lexan lid prevents direct entry from outside air while allowing clear view of drawer interior. Drawer movement is controlled by a large aluminum handle on rear. Front of unit is stainless steel. Easy operation is allowed by smooth running ball bearing extension slides.

Drawer is furnished with bill clip and brush type coin pad and locks with drop bolt through bottom of drawer into housing.

**Construction:**  
Stainless steel hood and front panel

| Model   | Dimensions |     |
|---------|------------|-----|
|         | D          | F   |
| 1724 WW | 24.25"     | 11" |
| 1728 WW | 28.25"     | 15" |

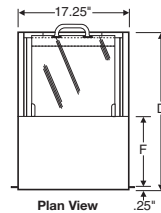
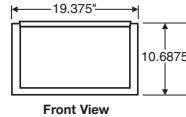
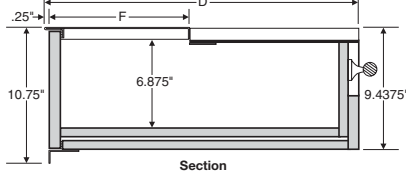

### A Series Transaction Drawers

A Series Transaction Drawers are weather resistant as well as bullet resistant. The front stainless steel panel pivots upward as drawer moves outward. Drawer movement is provided by smooth extension slides. It locks with drop bolt. Lexan lid stays closed as drawer is extended.

**Construction:**  
Drawer unit: aluminum frame, stainless steel hood, bullet resistant plastic

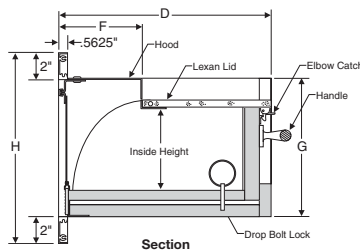
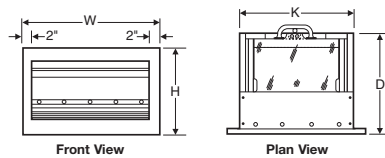

| Model | Overall Size |         |         |        | Inside Drawer Dimensions |     |        |         | Wall Opening |                 |
|-------|--------------|---------|---------|--------|--------------------------|-----|--------|---------|--------------|-----------------|
|       | W            | H       | D       | F      | G                        | K   | Width  | Height  | Depth        | Width x Height  |
| 1715A | 20.875"      | 13.125" | 15"     | 6.25"  | 9.4375"                  | 17" | 12.75" | 5.25"   | 12.375"      | 17.5" x 9.625"  |
| 1818A | 21.875"      | 15.625" | 18"     | 7.625" | 11.6875"                 | 18" | 13.75" | 7.5"    | 15.375"      | 18.5" x 12"     |
| 1824A | 21.875"      | 18.75"  | 24"     | 10.75" | 14.8125"                 | 18" | 13.75" | 10.625" | 21.375"      | 18.5" x 15.125" |
| 2725A | 30.875"      | 14.75"  | 24.75"  | 11.25" | 11.3125"                 | 27" | 22.75" | 7.375"  | 22.125"      | 27.5" x 11.625" |
| 1224A | 15.875"      | 15.875" | 24.125" | 8.25"  | 12"                      | 12" | 8"     | 8"      | 21"          | 12.5" x 12.5"   |



### Transaction Drawer 2725-SS

Transaction Drawer 2725-SS is designed for exterior walk-up and drive-up service. This drawer is weather resistant as well as bullet resistant. Stainless steel front panel pivots upward and inward as drawer moves outward. Movement is provided by smooth running extension slides. Drawer locks with drop bolt. Coin scoop and bill clip are included. Clear Lexan lid allows clear view of contents.

**Construction:**  
Drawer and housing: bullet resistant plastic

**Face, hood, and coin scoop:**  
Stainless steel

**Drawer extension:**  
19"

**Wall opening size:**  
27.375" wide x 11.5" high

**Drawer inside dimension:**  
23.25" wide x 22.5" deep x 7.5" high

**Level I bullet resistant**

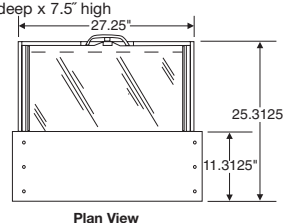
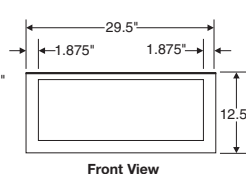
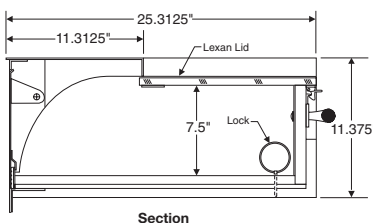

## Deal Trays



Deal Tray 1210-CT and 1610-CT



Step Deal Tray HCT



Deal Tray 1210-S, 1610-S and 1411-S



Deal Trays Level III Protection



Deal Trays One Way Non-Ricochet

# Talk Thrus

## No. 5-D Talk Thru Patented

Five inch diameter cast stainless steel talk thru with vertical louvers provides natural voice transmission. No. 5-D Talk Thru is available for interior or exterior use (specify which) and fits glazing from .25" to 1.875" thick. Optional security screws and contraband screen are available.

Indicate glass thickness when ordering.

**Construction:**

Cast stainless steel

**Hole size:**

4" diameter

Level III bullet resistant



## No. 6-D Talk Thru

Round 6" diameter cast stainless steel talk thru design offers natural voice transmission with evenly spaced louvers. This unit is available as interior or exterior model (specify which). No. 6-D Talk Thru is adjustable for .25" to 1.875" thick glass. Glass thickness less than 1.1875" requires optional spacer ring.

Indicate glass thickness when ordering.

**Hole size:**

5" diameter

**Construction:**

Cast stainless steel

Level III bullet resistant



## No. 5-FR Talk Thru

Five inch diameter stainless steel talk thru has offset slots in front and rear to provide natural voice transmission. No. 5-FR Talk Thru is available as interior or exterior model (specify which) and fits glass from .25" to 1.25" thick.

Indicate glass thickness when ordering.

**Construction:**

Stainless steel

**Hole size:**

4" diameter

Level I bullet resistant



## No. 6-FR Talk Thru

Six inch diameter stainless steel talk thru has offset holes in front and rear to provide natural voice transmission. No. 6-FR Talk Thru is available as interior or exterior model (specify which). It fits glass from .25" to 1.875" thick.

Indicate glass thickness when ordering.

**Construction:**

Stainless steel

**Hole size:**

5" diameter

Level I or III bullet resistant



## No. 8-D Talk Thru

Draft-free 8.375" diameter cast aluminum talk thru is well suited for exposed application. Natural voice transmission is obtained through the tensed clear plastic diaphragm while eliminating air flow. Perforated clear security screen on customer side protects the diaphragm. Talk thru has bullet resistant shield on rear side. Unit is adjustable for glazing from .25" to 1.875" thick. Optional spacer ring is required for glass less than 1.1875" thick.

Indicate glass thickness when ordering.

**Construction:**

Cast aluminum

**Specify finish:**

Clear or dark bronze anodized

**Hole size:**

7.5" diameter

Level I or III bullet resistant



## No. 11-D Talk Thru

Draft-free 11" diameter cast aluminum talk thru is meant for exterior installations. This model is a larger version of our No. 8-D. No. 11-D Talk Thru is adjustable for glazing from .25" to 1.875" thick. Optional spacer ring is required for glass less than 1.1875" thick.

Indicate glass thickness when ordering.

**Construction:**

Cast aluminum

**Specify finish:**

Clear or dark bronze anodized

**Hole size:**

10" diameter

Level I or III bullet resistant



## SC-100 Talk Thru

Four inch diameter aluminum anodized two-way electronic talk thru provides amplified clear voice communication. Standard model has gooseneck microphone for operator and plugs into 115 volt duplex outlet for continuous duty. Battery pack is available for DC operation (specify model SC-100L).

Indicate glass thickness when ordering.

**Construction:**

aluminum

**Hole size:**

3.5" diameter

Level III bullet resistant





## Exterior Service Window

Exterior Service Window fits into rough wall opening and clamps onto wall. Adjustable extruded aluminum frame fits walls 5" to 8.5" thick. Window clamps in place with bolts positioned through back frame into threaded section of front frame. Glazing is sealed into the frame for weather tight installation. Stainless steel shelf has writing surface in front of built-in deal tray. Deal tray closure helps prevent drafts. Natural voice transmission is provided by the circular draft-free talk thru.

**Specify frame finish:**

Clear or dark bronze anodized aluminum

**Construction:**

Aluminum frame  
Stainless steel shelf

**Bullet resistant glazing available:**

1.25" acrylic Level I  
or 1.25" Lexgard Level III

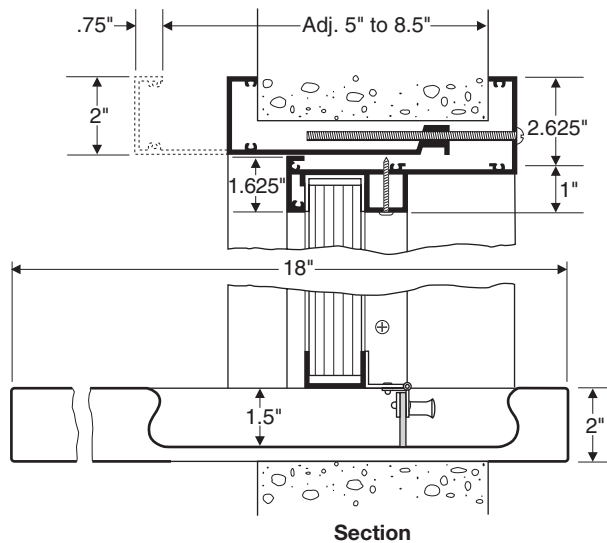

| Model    | Overall Size of Unit | Wall Opening   |
|----------|----------------------|----------------|
|          | Width x Height       | Width x Height |
| SWE 2436 | 24" x 36"            | 21.75" x 35"   |
| SWE 3036 | 30" x 36"            | 27.75" x 35"   |
| SWE 3636 | 36" x 36"            | 33.75" x 35"   |
| SWE 2442 | 24" x 42"            | 21.75" x 41"   |
| SWE 3042 | 30" x 42"            | 27.75" x 41"   |
| SWE 3642 | 36" x 42"            | 33.75" x 41"   |

## Exterior Service Window with Multi-Lites

Exterior Service Window with Multi-Lites has adjustable aluminum clamp-on frame to fit walls 5" to 8.25" thick. Mullions divide window into two or more lites. Glazing is sealed into frame for weather tight installation. Draft-free circular talk thrus allow natural voice communication. Stainless steel shelf has recessed deal trays with closures.

**Construction:**

Aluminum frame  
Stainless steel shelf

**Bullet resistant glazing available:**

1.25" acrylic Level I  
or 1.25" Lexgard Level III

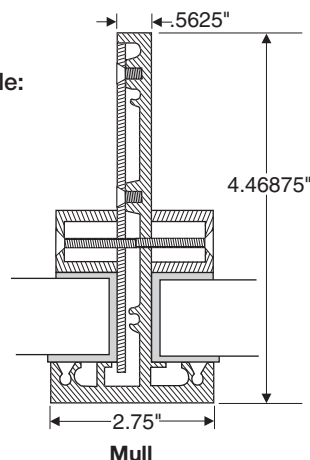

| Model       | Overall Size of Unit | Wall Opening   |
|-------------|----------------------|----------------|
|             | Width x Height       | Width x Height |
| SWE-ML 7236 | 72" x 36"            | 69.75" x 35"   |
| SWE-ML 8436 | 84" x 36"            | 81.75" x 35"   |
| SWE-ML 9636 | 96" x 36"            | 93.75" x 35"   |

# Windows



## Service Window with Aluminum Clamp-on Frame

Bullet resistant window fits into rough wall opening and clamps onto finished wall. Extruded aluminum frame adjusts for walls 5" to 8.5" thick. Window unit clamps into place with bolts positioned through back frame into threaded section of front frame.

Glazing is held in place with rubber spacers, providing space around sides and top for natural voice transmission. Stainless steel shelf with built-in tray is fastened into frame. Choice of glazing. Entire unit is shipped fully assembled. This model is for interior use only.

### Specify frame finish:

Clear or dark bronze anodized aluminum

### Construction:

Aluminum frame  
Stainless steel shelf and tray

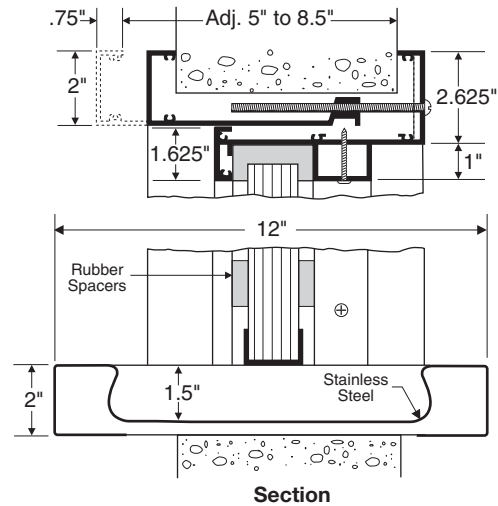

| Model    | Overall Size of Unit | Wall Opening   |
|----------|----------------------|----------------|
|          | Width x Height       | Width x Height |
| SWA 2436 | 24" x 36"            | 21.75" x 35"   |
| SWA 3036 | 30" x 36"            | 27.75" x 35"   |
| SWA 3636 | 36" x 36"            | 33.75" x 35"   |
| SWA 4836 | 48" x 36"            | 45.75" x 35"   |
| SWA 6036 | 60" x 36"            | 57.75" x 35"   |
| SWA 7236 | 72" x 36"            | 69.75" x 35"   |
| SWA 3042 | 30" x 42"            | 27.75" x 41"   |
| SWA 3642 | 36" x 42"            | 33.75" x 41"   |
| SWA 4842 | 48" x 42"            | 45.75" x 41"   |
| SWA 6042 | 60" x 42"            | 57.75" x 41"   |
| SWA 7242 | 72" x 42"            | 69.75" x 41"   |

Special sizes are available upon application.



## Vision Window with Aluminum Clamp-On Frame

Bullet resistant Vision Window with Aluminum Clamp-on Frame is identical to our Service Window above except for a frame along bottom in place of stainless steel shelf and deal tray.

### Specify frame finish:

Clear or dark bronze anodized aluminum

### Construction:

Aluminum frame

| Model      | Overall Size of Unit | Wall Opening    |
|------------|----------------------|-----------------|
|            | Width x Height       | Width x Height  |
| VWACL 2436 | 24" x 36"            | 21.75" x 33.75" |
| VWACL 3036 | 30" x 36"            | 27.75" x 33.75" |
| VWACL 3636 | 36" x 36"            | 33.75" x 33.75" |
| VWACL 4836 | 48" x 36"            | 45.75" x 33.75" |
| VWACL 6036 | 60" x 36"            | 57.75" x 33.75" |
| VWACL 7236 | 72" x 36"            | 69.75" x 33.75" |
| VWACL 3042 | 30" x 42"            | 27.75" x 39.75" |
| VWACL 3642 | 36" x 42"            | 33.75" x 39.75" |
| VWACL 4842 | 48" x 42"            | 45.75" x 39.75" |
| VWACL 6042 | 60" x 42"            | 57.75" x 39.75" |
| VWACL 7242 | 72" x 42"            | 69.75" x 39.75" |

## Exchange Window

Exchange Window with natural voice transmission mounts into masonry opening or into bullet resistant reinforced stud wall. It can be made in single or multiple lites. The window frame is extruded aluminum and is fastened together with screws. Glazing material is held in place with rubber spacers which provide open space around side and top for natural voice transmission. Stainless steel shelf with built-in deal tray fits below window lite. Choice of bullet resistant glazing. Exchange window is for interior use only.

**Specify frame finish:**

Clear or dark bronze anodized aluminum

**Construction:**

Aluminum frame  
Stainless steel shelf

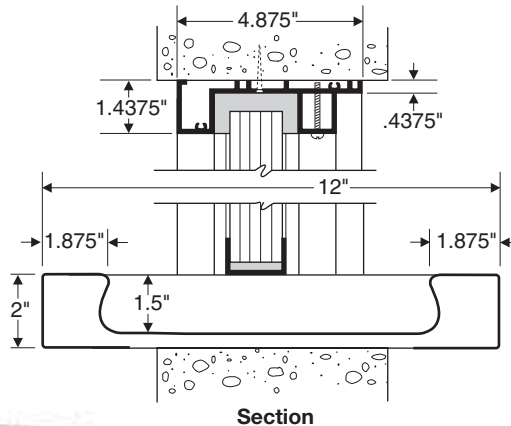

Exchange Window with Multi-lites available in custom sizes. Priced upon application.

| Model   | Width x Height | Model   | Width x Height |
|---------|----------------|---------|----------------|
| XW 2430 | 24" x 30"      | XW 2436 | 24" x 36"      |
| XW 3030 | 30" x 30"      | XW 3036 | 30" x 36"      |
| XW 3630 | 36" x 30"      | XW 3636 | 36" x 36"      |
|         |                | XW 4836 | 48" x 36"      |
|         |                | XW 6036 | 60" x 36"      |
|         |                | XW 7236 | 72" x 36"      |

## Exchange Vision Window

Exchange Vision Window has natural voice transmission. This window is identical to Exchange Window above except the shelf is omitted and replaced with aluminum frame along bottom edge.

**Specify frame finish:**

Clear or dark bronze anodized aluminum

**Construction:**

Aluminum frame

| Model    | Width x Height | Model    | Width x Height |
|----------|----------------|----------|----------------|
| XVW 2430 | 24" x 30"      | XVW 2436 | 24" x 36"      |
| XVW 3030 | 30" x 30"      | XVW 3036 | 30" x 36"      |
| XVW 3630 | 36" x 30"      | XVW 3636 | 36" x 36"      |
|          |                | XVW 4836 | 48" x 36"      |
|          |                | XVW 6036 | 60" x 36"      |

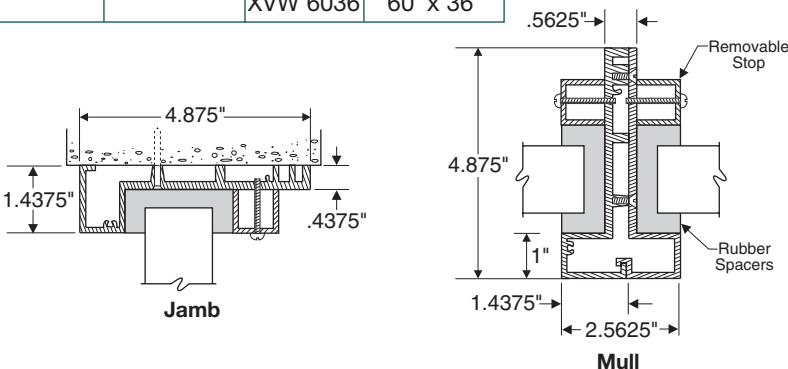

# Windows

## Vision Window

Vision Windows are available in single, double or triple lites. Corner and bay windows are available upon request. Window frame is extruded aluminum fastened together with screws, available in clear or dark bronze anodized finish. Vision windows are shipped without glazing material permanently installed. Glazing material must be sealed into framing after frame is anchored in place. Sealant to be furnished by installer.

Vision Window provides walk-up or drive-up service with the addition of circular talk thru and transaction drawer.

### Specify frame finish:

Clear or dark bronze anodized aluminum

### Construction:

Aluminum frame

|             | Model       | Width x Height |
|-------------|-------------|----------------|
| Single Lite | VWS 2436    | 24" x 36"      |
|             | VWS 3036    | 30" x 36"      |
|             | VWS 3636    | 36" x 36"      |
|             | VWS 4836    | 48" x 36"      |
|             | VWS 6036    | 60" x 36"      |
| Double Lite | VWS-2 9636  | 96" x 36"      |
|             | VWS-2 12036 | 120" x 36"     |
| Triple Lite | VWS-3 14436 | 144" x 36"     |
|             | VWS-3 18036 | 180" x 36"     |

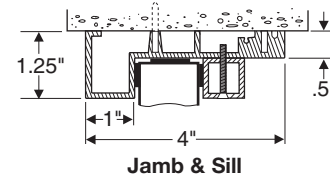
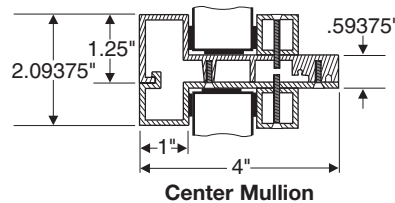
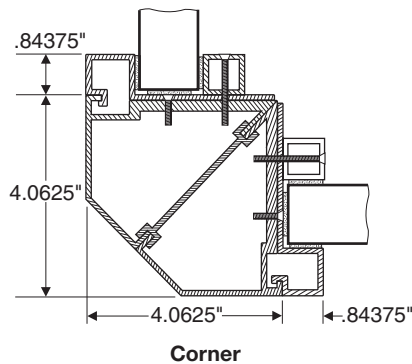

## Sliding Window

Window unit has a stationary lite as well as a sliding lite which opens for daytime use. Window lite slides closed via overhead track for nighttime security. Frame available in clear or dark bronze anodized aluminum. Shelf is available in stainless steel or plastic laminated with stainless steel deal tray mounted below sliding window when in closed position. Unit is available with level I bullet resistant acrylic or level III bullet resistant polycarbonate. Window can be made to User or Project specified sizes. This model is for interior use only.

### Specify frame finish:

Clear or dark bronze anodized aluminum

### Construction:

Shelf: Stainless steel or plastic laminated

Level I acrylic or level III polycarbonate bullet resistant

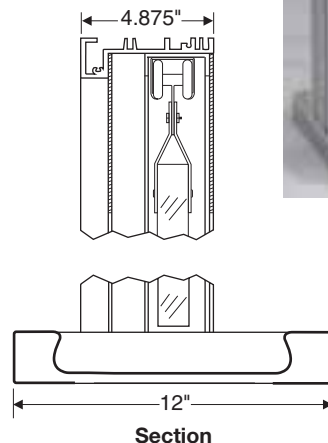



## Ticket Window

Creative Industries bullet resistant Ticket Window features aluminum clamp-on frame adjustable for walls 5" to 8.5" thick, two-way voice amplified bullet resistant talk thru is mounted in choice of glazing. The unique patented counter top and drawer combination is constructed of stainless steel and weatherstripped to minimize energy loss. Drawer moves forward quietly on solid bearing slides and blends smoothly into frontal surface of shelf when closed, making desirable flush appearance. Counter top extends in front of window to provide customer with extra space for writing surface or purse ledge. Window frame is available in clear or dark bronze anodized finish.

### Specify frame finish:

Clear or dark bronze anodized aluminum

### Construction:

Frame: aluminum

Counter top and drawer: stainless steel

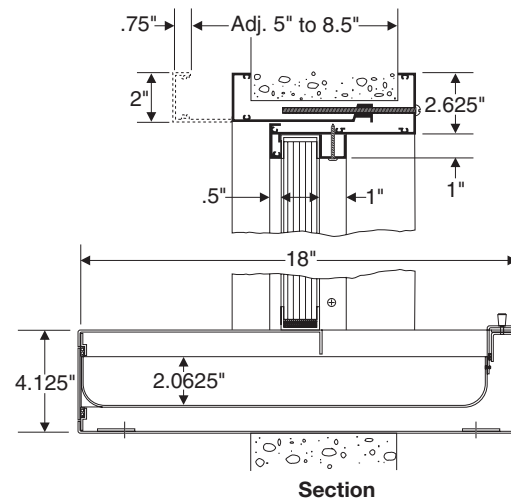

| Model    | Overall Size of Unit | Wall Opening   |
|----------|----------------------|----------------|
|          | Width x Height       | Width x Height |
| TIK 2436 | 24" x 36"            | 21.75" x 35"   |
| TIK 2442 | 24" x 42"            | 21.75" x 41"   |
| TIK 2448 | 24" x 48"            | 21.75" x 47"   |



## Walk-Up Window

Creative Industries' bullet resistant Walk-Up Window has an aluminum frame. Patented stainless steel counter top with drawer leaves space in front of window for writing surface or purse ledge. Weatherstripped drawer extends out to customer for access to contents.

Natural voice transmission is furnished by Creative's patented model No. 5-D\* cast stainless steel talk thru. Walk-Up Window is shipped without glazing material permanently installed. Sealant to be furnished by installer.

### Construction:

Frame: aluminum

Counter top and drawer: stainless steel

Talk thru: cast stainless steel

\*No. 5-D Talk Thru is described in further detail in another section of this catalog.

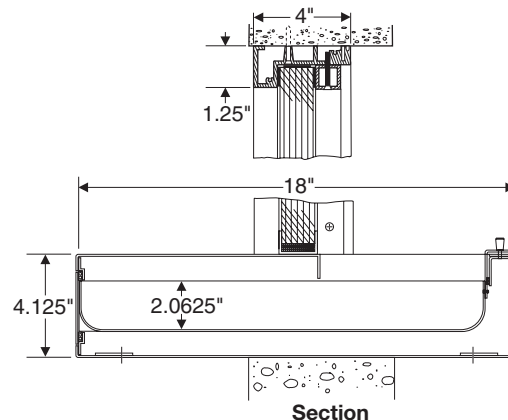

| Model   | Overall Size of Unit | Wall Opening    |
|---------|----------------------|-----------------|
|         | Width x Height       | Width x Height  |
| WU 2436 | 24" x 36"            | 24.25" x 36.25" |
| WU 3036 | 30" x 36"            | 30.25" x 36.25" |
| WU 3636 | 36" x 36"            | 36.25" x 36.25" |

# Windows



## NW-PH 1632 Nite Window with Pass Hopper

Nite Window with Pass Hopper fits into wall opening of 16.25" x 32.25". Aluminum frame has clear or dark bronze anodized finish. Unit includes PHE-1 stainless steel Pass Hopper,\* weatherstripped for exterior use and our No. 6-FR\* stainless steel draft-free talk thru. Window has 1.25" thick Level I bullet resistant acrylic glazing.

### Specify frame finish:

Clear or dark bronze anodized aluminum

### Glazing:

1.25" Level I bullet resistant acrylic

\* PHE-1 Pass Hopper and No. 6-FR Talk Thru described in further detail in other sections of this catalog.



## NW-DT 1624 Nite Window with Deal Tray

Compact Nite Window with Deal Tray fits into 16.25" x 24.25" wall opening. Glazing is 1.25" thick acrylic with Level I bullet resistant protection and aluminum frame in clear or dark bronze anodized finish. Window unit has No. 6-FR\* stainless steel draft-free talk thru and stainless steel deal tray with hinged draft closure.

### Specify frame finish:

Clear or dark bronze anodized aluminum

### Glazing:

1.25" Level I bullet resistant acrylic

\*No. 6-FR Talk Thru described in further detail on page 15 of this catalog.

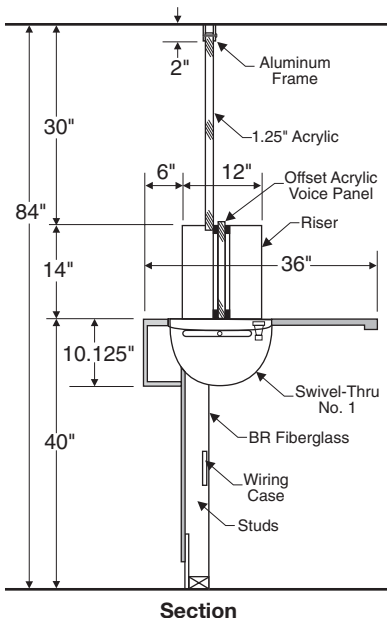

## Bullet Resistant Teller Counter Model BRTC-STH

Bullet Resistant Teller Counter Model BRTC-SWTH is furnished with No. 1 Swivel-Thru\* combination pass thru and deal tray. It has a natural voice transmission acrylic panel at deal area, with acrylic panels above risers set in aluminum frames. Teller counter unit includes counter top, risers and counter front with bullet resistant fiberglass panels on rear side. Electrical duplex outlets are mounted on rear side of risers (wiring by others).

**Standard size:**  
60" wide x 84" high

**Glazing:**  
1.25" Level I bullet resistant acrylic

\* No. 1 Swivel Thru described in further on page 6 of this catalog.





## Exchange Window with Lazy Susan

This double lite window unit is for interior use only. Window has natural voice transmission inside aluminum frame. Deal tray is provided for currency transactions while Lazy Susan\* pass thru handles larger items for transfer. Choice of plastic laminate on shelf.

Choice of glazing.

**Specify frame finish:**

Clear or dark bronze anodized aluminum

**Construction:**

Aluminum frame  
Stainless steel shelf

**Overall size:**

36" wide x 36" high  
Other sizes available

\*Lazy Susan is described in further detail on page 3 of this catalog.

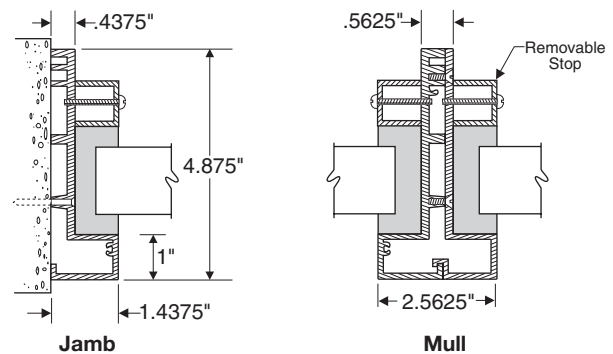

## Exchange Window with Hinged Panel

Exchange window with natural voice transmission has hinged panel which swings up for transfer of larger items. Stainless steel shelf with integral deal tray fits below window. This model for interior use only.

**Note:** GLASS IS NOT AVAILABLE for Exchange Window with Hinged Panel.

**Construction:**

Aluminum frame  
Stainless steel shelf

**Hinged panel size:**

15" wide x 6" high

**Bullet resistant glazing available:**

1.25" acrylic Level I  
or 1.25" Lexgard Level III



**Lock detail:** Channel shaped pull protects against tampering with slide bolt lock.

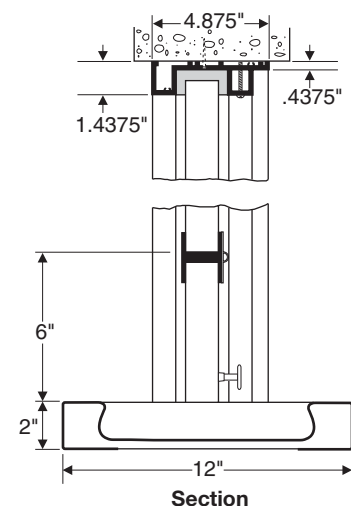

| Model      | Width x Height |
|------------|----------------|
| XW-HP 2430 | 24" x 30"      |
| XW-HP 3030 | 30" x 30"      |
| XW-HP 3630 | 36" x 30"      |
| XW-HP 2436 | 24" x 36"      |
| XW-HP 3036 | 30" x 36"      |
| XW-HP 3636 | 36" x 36"      |



## Flip Window (Non-Bullet Resistant)

The Flip Window is designed to allow less entry of outside air into the building than normal sliding window. The window pivots for easy opening and closing. When open the front edge of window extends out only 8.5" from sill. Flip window mounts between mullions for retrofit.

Choice of glazing .25" Lexan or .25" tempered glass. The window locks with spring loaded dead bolt and has brush type weatherstrip.

### Specify frame finish:

Clear or dark bronze anodized aluminum

### Standard size:

21.75" wide x 21" high overall with a clear opening of 15.5" x 17.5" high  
Custom sizes are available

### Choice of glazing:

.25" Lexan or .25" tempered glass

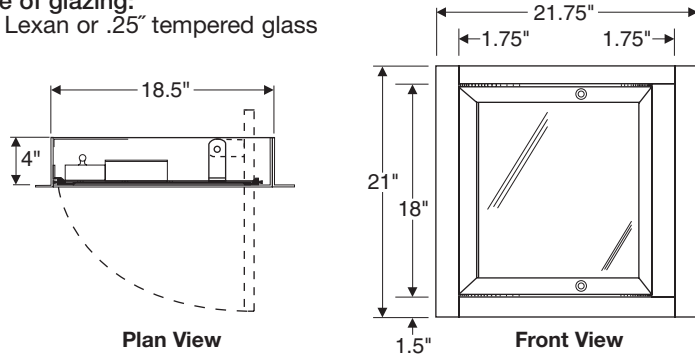

## Flip Window with Transom (Non-Bullet Resistant)

For new construction or retrofit, this unit can replace moveable section of existing sliding window, reducing the size of the window which opens to the customer. Custom sizes and configurations available upon application.

### Standard size:

24" wide x 36" high overall

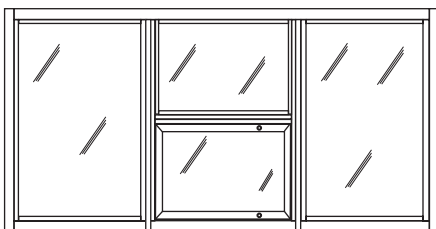
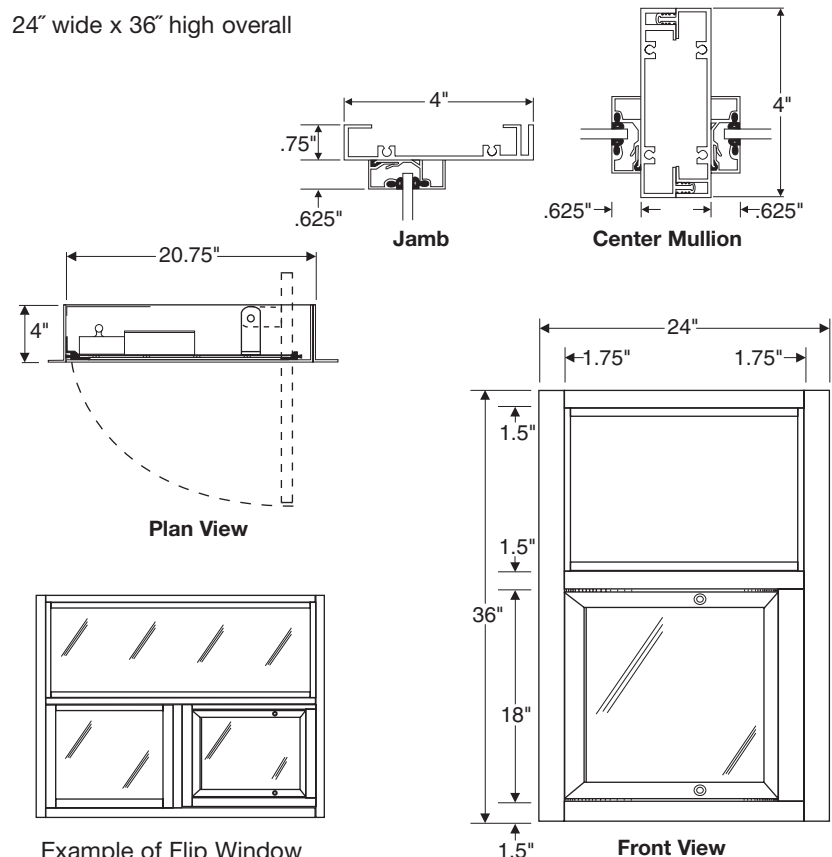
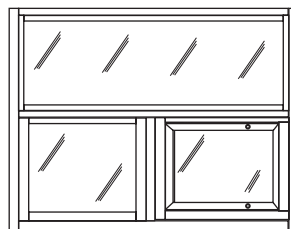

Illustration of Flip Window with transom shown between two side lites.



Example of Flip Window below full width transom.