

Schindler Ceilings

For hydraulic and traction elevators

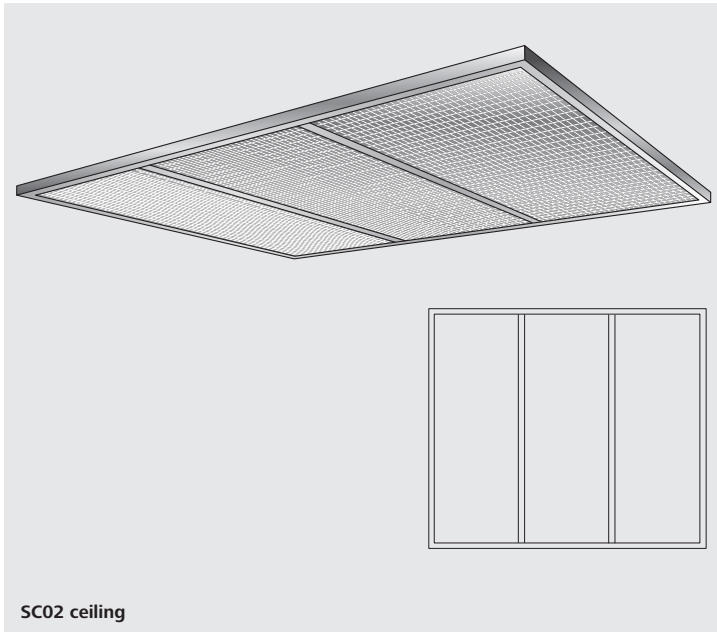

SC02 ceiling

The SC02 suspended ceiling has a clear anodized aluminum three-section exposed frame with lay-in panels and features fluorescent lighting.

- Ceiling provided with 1 1/2" between edge of ceiling and wall
- Suspended ceiling hangs 7" below canopy
- For all capacities.

Frame finish

- Brushed aluminum*
- Bronze painted to match bronze cab treatments.

Lay-in panel finish

- Removable flat, translucent, non-combustible Lexan® panels
- 5/8" x 5/8" x 3/8" Aluminum eggcrate panels.*

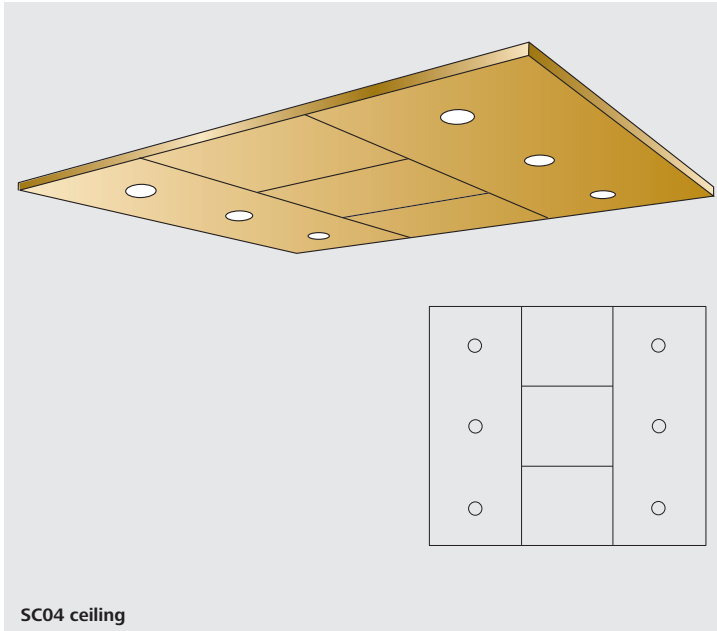

SC04 ceiling

The SC04 ceiling is suspended with a concealed frame, and features compact fluorescent lights.

- Ceiling provided with 1 1/2" nominal space between edge of ceiling and wall
- Suspended ceiling hangs 7" below canopy
- For 2100 lb., 2500 lb., 3000 lb., and 3500 lb. capacities.

Ceiling panel finish

- #4 Brushed stainless steel
- #4 Brushed bronze*
- #8 Mirror stainless steel
- #8 Mirror bronze
- Baked enamel color.**

KT
Kits

AC
Accessories

CW
Counter-weights

SA
Safeties

FI
Fixtures

CA
Cars

DO
Doors

MM
Mechanical material

CO
Controls

DR
Drives



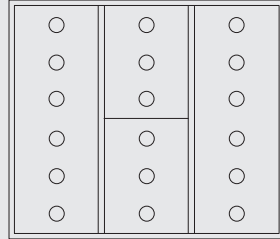
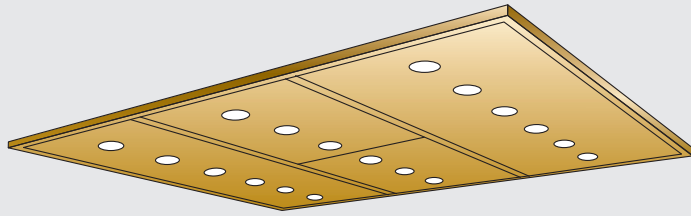

SC05 ceiling

SC05 ceiling

The SC05 suspended ceiling has a clear anodized aluminum three-section exposed frame with lay-in panels and features eighteen 20-watt incandescent downlights.

- Ceiling provided with 1 1/2" between edge of ceiling and wall
- Suspended ceiling hangs 7" below canopy
- For 2100 lb., 2500 lb., 3000 lb., and 3500 lb. capacities
- Not available with Schindler 330A® and Schindler 400A® models.

Frame finish

- Brushed aluminum
- Bronze painted to match bronze lay-in panels.*

Lay-in panel finish

- #4 Brushed stainless steel
- #4 Brushed bronze*
- Baked enamel color.**

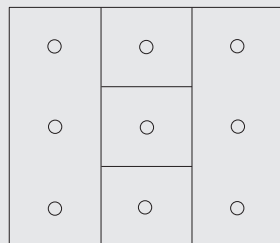
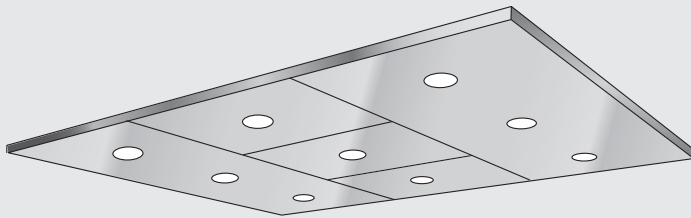

SC08 ceiling

SC08 ceiling

The SC08 ceiling is suspended with a concealed frame, and features compact fluorescent lights.

- Ceiling provided with 1 1/2" nominal space between edge of ceiling and wall
- Suspended ceiling hangs 7" below canopy
- For all capacities.

Ceiling panel finish

- #4 Brushed stainless steel
- #4 Brushed bronze
- #8 Mirror stainless steel*
- #8 Mirror bronze
- Baked enamel color.**

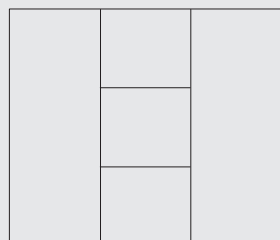
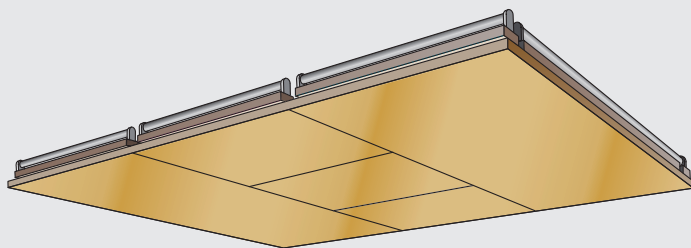

SC09 ceiling

SC09 ceiling

The SC09 ceiling is suspended with a concealed frame, and features ceiling panels with concealed fluorescent perimeter lighting (a mix of T8 lamps).

- Ceiling provided with 4" between edge of ceiling and wall
- Suspended ceiling hangs 7" below canopy
- For 2100 lb., 2500 lb., 3000 lb., 3500 lb., 4000 lb. (hospital/service only), 4500 lb. and 5000 lb. capacities.

Ceiling panel finish

- #4 Brushed stainless steel
- #4 Brushed bronze
- #8 Mirror stainless steel
- #8 Mirror bronze*
- Baked enamel color.**

SC10 ceiling

The SC10 steel canopy ceiling is finished in baked enamel and features a lighting fixture with two 40 watt fluorescent bulbs protected by an opaque, white polycarbonate cover.

- One fixture is used in cars with 2100 lb., 2500 lb., 3000 lb. and 3500 lb. capacities
- Two fixtures are used in 4000 lb., 4500 lb. and 5000 lb. hospital/service cars.

Canopy finish

- Prefinished in white baked enamel color (E050).**

SC11 ceiling

The SC11 suspended ceiling has a clear anodized aluminum three-section exposed frame with 7" diameter cutouts in the metal panels. Translucent plastic panels inserted above the ceiling panels serve as diffusers for the fluorescent disc lighting.

- Ceiling provided with 1 1/2" between edge of ceiling and wall
- Suspended ceiling hangs 7" below canopy
- Available with Schindler 330A and Schindler 400A models only; all capacities.

Frame finish

- Brushed aluminum*
- Bronze painted to match bronze cab treatments.

Lay-in panel finish

- #4 Brushed stainless steel*
- #4 Brushed bronze
- #8 Mirror stainless steel
- #8 Mirror bronze
- Baked enamel color.**

* Frame and/or panel illustrated. Color(s) illustrated may vary from actual color.

** Refer to Schindler's Palette standard baked enamel finish brochure (SAN-1001a) for baked enamel color selections available with all Schindler ceilings.

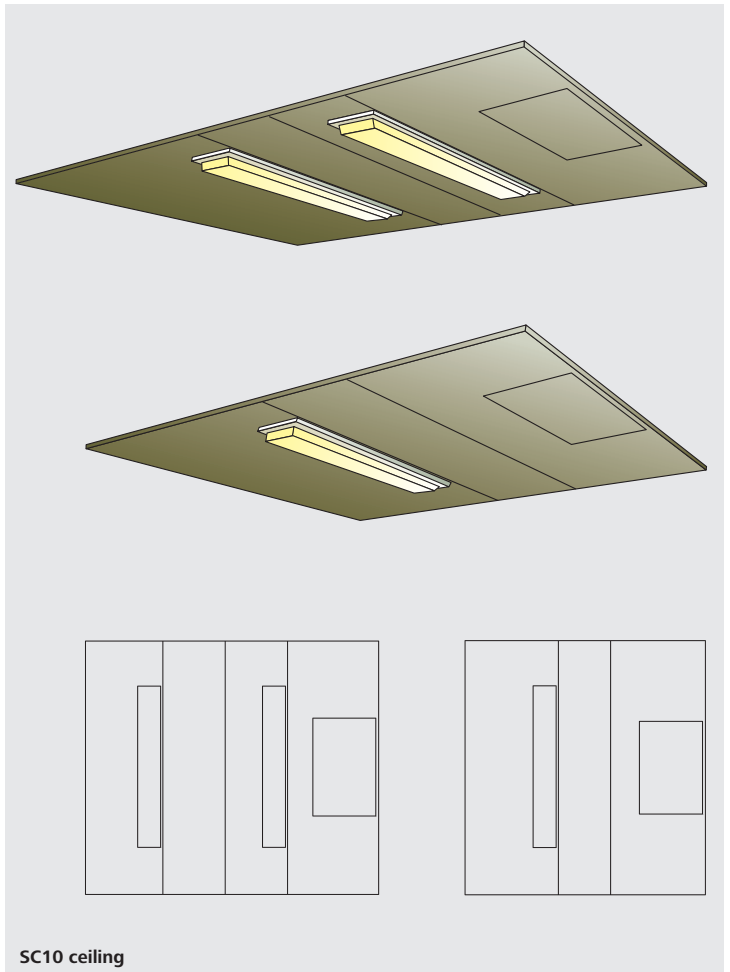

SC10 ceiling

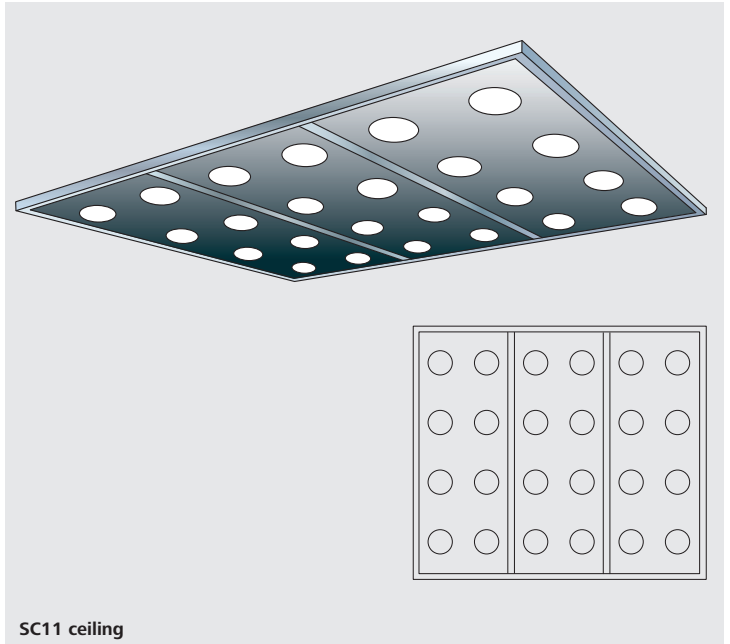

SC11 ceiling

Schindler Ceilings

For hydraulic and traction elevators

Approvals

Project _____

Car Number _____

Location _____

Approved _____

Contract # _____

Date _____

SC02 ceiling

Frame finish

- Brushed aluminum
- Bronze painted to match bronze cab treatments

Lay-in panel finish

- Removable flat, translucent, non-combustible Lexan® panels
- 5/8" x 5/8" x 3/8" Eggcrate panels with flat, translucent light diffusion panel

SC04 ceiling

Ceiling panel finish

- #4 Brushed stainless steel
- #4 Brushed bronze
- #8 Mirror stainless steel
- #8 Mirror bronze
- Baked enamel color**

Code/Name _____

SC05 ceiling

Frame finish

- Brushed aluminum
- Bronze painted to match bronze lay-in panels

Lay-in panel finish

- #4 Brushed stainless steel
- #4 Brushed bronze
- Baked enamel color**

Code/Name _____

SC08 ceiling

Ceiling panel finish

- #4 Brushed stainless steel
- #4 Brushed bronze
- #8 Mirror stainless steel
- #8 Mirror bronze
- Baked enamel color**

Code/Name _____

SC09 ceiling

Ceiling panel finish

- #4 Brushed stainless steel
- #4 Brushed bronze
- #8 Mirror stainless steel
- #8 Mirror bronze
- Baked enamel color**

Code/Name _____

SC10 ceiling

Canopy finish

- Prefinished white baked enamel color (E050)**

SC11 ceiling

Frame finish

- Brushed aluminum
- Bronze painted to match bronze cab treatments

Lay-in panel finish

- #4 Brushed stainless steel
- #4 Brushed bronze
- #8 Mirror stainless steel
- #8 Mirror bronze
- Baked enamel color**

Code/Name _____

** Refer to Schindler's Palette standard baked enamel finish brochure (SAN-1001a) for baked enamel color selections available with all Schindler ceilings.

Lexan is a Registered Trademark of GE.

For further information including location of the Schindler office nearest you, please visit:

www.us.schindler.com

North American Headquarters
Morristown, New Jersey 07962-1935
Tel. 973.397.6500



Schindler prints with soy ink on recycled paper.