

The application and detail drawings in this manual are strictly for illustration purposes and may not be applicable to all building designs or product installations. All projects should conform to applicable building codes for that particular area. It is recommended to follow all building regulations and standard industry practices.

Metal Sales Manufacturing Corporation is not responsible for the performance of the roof system if it is not installed in accordance with the suggested instructions referenced in this manual. If there is a conflict between this manual and the approved Metal Sales' erection drawings, the approved erection drawings are to take precedence.

Prior to ordering and installing materials, all dimensions should be verified by field measurements.

Oil canning is not a cause for rejection. Oil canning can be described as the amount of waviness found in the flat areas of metal panels. Oil canning is an inherent characteristic of light gauge cold formed metal products, particularly those with broad flat areas. There are many factors which may contribute to oil canning that Metal Sales is not able to control. These factors include: misalignment of the support system, over driving of fasteners used on the panels, stress (whether inherent in the panel or induced), thermal expansion and contraction of the panel, material handling, width, gauge, length, color of panels and installation. (reference Metal Construction Association "Oil Canning Position Paper" - Appendix A).

Metal Sales reserves the right to modify, without notice, any details, recommendations or suggestions. Any questions you may have regarding proper installation of the T-Armor Series roofing system should be directed to your Metal Sales representative (see pages 2 and 3).

Consult Metal Sales for any additional information not addressed in this manual.

This manual is designed to be utilized as a guide when installing T-Armor roofing system. It is the responsibility of the erector to ensure the safe installation of this product system.

SAFETY

STUDY APPLICABLE OSHA AND OTHER SAFETY REQUIREMENTS BEFORE FOLLOWING THESE INSTRUCTIONS.

The installation of metal roof systems is a dangerous undertaking and should be supervised by trained, knowledgeable erectors. **USE EXTREME CARE WHILE INSTALLING ROOF PANELS.** It is not possible for Metal Sales to be aware of all the possible job site situations that could cause an unsafe condition to exist. The erector of the roof system is responsible for reading these instructions and determining the safest way to install the roof system.

These instructions are provided only as a guide to show a knowledgeable, trained erector the correct parts placement one to another. If following any of the installation steps would endanger a worker, the erector should stop work and decide upon a corrective action.

Provide required safety railing, netting or safety lines for crew members working on the roof.

Do not use the roof panel as a walking platform. The roof panels will not withstand the weight of a person standing at the edge of the panel.

Do not stand on any part of a roof panel until the panel has been completely attached.

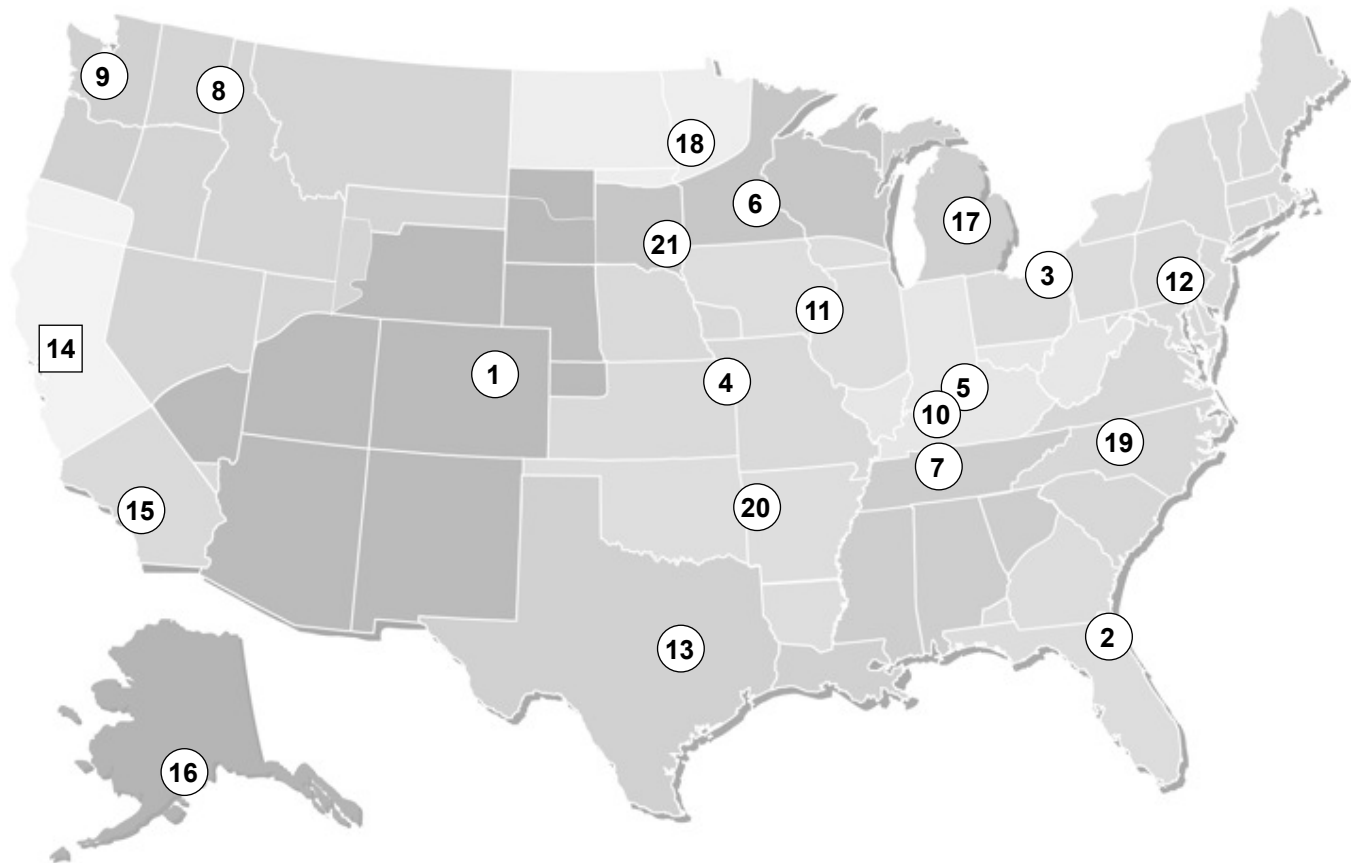

*NOTE: Shaded areas represent regions served by each location.



Indicates Metal Sales branch manufactures T-Armor Series Panels

Metal Sales offers a complete line of metal roof, wall, and fascia panel systems for the commercial, architectural, industrial, residential, and markets. Metal Sales offers over 75 profiles with a wide selection of widths, colors, and gauges - new construction or retrofit.

1.) DENVER BRANCH

7990 East I-25 Frontage Road
Longmont, CO 80504
303.702.5440 Phone
800.289.7663 Toll Free
800.289.1617 Toll Free Fax

2.) JACKSONVILLE BRANCH

7110 Stuart Avenue
Jacksonville, FL 32254
904.783.3660 Phone
800.394.4419 Toll Free
904.783.9175 Fax
800.413.3292 Toll Free Fax

3.) JEFFERSON BRANCH

352 East Erie Street
Jefferson, OH 44047
440.319.3779 Phone
800.321.5833 Toll Free
440.576.9242 Fax
800.233.5719 Toll Free Fax

4.) INDEPENDENCE BRANCH

1306 South Powell Road
Independence, MO 64057
816.796.0900 Phone
800.747.0012 Toll Free
816.796.0906 Fax

5.) SELLERSBURG BRANCH

7800 State Road 60
Sellersburg, IN 47172
812.246.1866 Phone
800.999.7777 Toll Free
812.246.0893 Fax
800.477.9318 Toll Free Fax

6.) ROGERS BRANCH

22651 Industrial Boulevard
Rogers, MN 55374
763.428.8080 Phone
800.328.9316 Toll Free
763.428.8525 Fax
800.938.9119 Toll Free Fax

7.) NASHVILLE BRANCH

4314 Hurricane Creek Boulevard
Antioch, TN 37013
615.229.6570 Phone
800.251.8508 Toll Free
615.283.4283 Fax
800.419.4372 Toll Free Fax

8.) SPOKANE BRANCH

East 2727 Trent Avenue
Spokane, WA 99202
509.536.6000 Phone
800.572.6565 Toll Free
509.534.4427 Fax

9.) SEATTLE BRANCH

20213 84th Avenue, South
Kent, WA 98032
253.872.5750 Phone
800.431.3470 Toll Free (Outside WA)
800.742.7900 Toll Free (Inside WA)
253.872.2008 Fax

10.) NEW ALBANY BRANCH

999 Park Place
New Albany, IN 47150
812.944.2733 Phone
812.944.1418 Fax

11.) ROCK ISLAND BRANCH

8111 West 29th Street
Rock Island, IL 61201
309.787.1200 Phone
800.747.1206 Toll Free
309.787.1833 Fax

12.) DEER LAKE BRANCH

29 Pinedale Industrial Road
Orwigsburg, PA 17961
570.366.2020 Phone
800.544.2577 Toll Free
570.366.1648 Fax
800.544.2574 Toll Free Fax

13.) TEMPLE BRANCH

3838 North General Bruce Drive
Temple, TX 76501
254.791.6650 Phone
800.543.4415 Toll Free
254.791.6655 Fax
800.543.4473 Toll Free Fax

14.) WOODLAND BRANCH

1326 Paddock Place
Woodland, CA 95776
530.668.5690 Phone
800.759.6019 Toll Free
530.668.0901 Fax

15.) FONTANA BRANCH

14213 Whittram Avenue
Fontana, CA 92335
909.829.8618 Phone
800.782.7953 Toll Free
909.829.9083 Fax

16.) ANCHORAGE BRANCH

4637 Old Seward Highway
Anchorage, AK 99503
907.646.7663 Phone
866.640.7663 Toll Free
907.646.7664 Fax

17.) BAY CITY BRANCH

5209 Mackinaw Road
Bay City, MI 48706
989.686.5879 Phone
888.777.7640 Toll Free
989.686.5870 Fax
888.777.0112 Toll Free Fax

18.) DETROIT LAKES BRANCH

1435 Egret Avenue
Detroit Lakes, MN 56501
218.847.2988 Phone
888.594.1394 Toll Free
218.847.4835 Fax
888.594.1454 Toll Free Fax

19.) MOCKSVILLE BRANCH

188 Quality Drive
Mocksville, NC 27028
704.859.0550 Phone
800.228.6119 Toll Free
704.859.0157 Fax
800.228.7916 Toll Free Fax

20.) FORT SMITH BRANCH

7510 Ball Road
Fort Smith, AR 72908
479.646.1176 Phone
877.452.3915 Toll Free
479.646.5204 Fax

21.) SIOUX FALLS BRANCH

2700 West 3rd Street, Suite 4
Sioux Falls, SD 57104
605.951.0367 Phone
888.299.0024 Toll Free

TECHNICAL SUPPORT**TECHNICAL SERVICES**

545 South 3rd Street, Suite 200
Louisville, KY 40202
502.855.4300 Phone
800.406.7387 Toll Free
502.855.4290 Fax
800.944.6884 Toll Free Fax

| SECTION | PAGE NO. |
|---|-----------------|
| General Information | |
| Important Information | 1 |
| Metal Sales Locations | 2 |
| Customer Service | 3 |
| Table of Contents | 4 & 5 |
| Flashing Angle Chart | 6 |
| Panel Profiles | |
| Flat Panel Profile..... | 7 |
| Pencil Rib Panel Profile..... | 8 |
| Minor Rib Panel Profile | 9 |
| Striated Panel Profile | 10 |
| Mesa Panel Profile..... | 11 |
| Plank Panel Profile..... | 12 |
| Accessory Profiles | 13-16 |
| Flashing Profiles | 17-23 |
| Fastener Selection Guide | 24 |
| Fastener Technical Information | |
| Physical Properties | 25 |
| Pull Out Strength Values..... | 26 |
| Pull Over Strength Values..... | 27 |
| Testing Information | |
| UL 580 Wind Uplift Information | 28-30 |
| UL 263 Fire Resistance Rating | 31 |
| Testing Summary | 31 |
| Section Properties and Load Tables | |
| 2 ³ / ₈ " Steel Panel Properties..... | 32 |
| 2 ³ / ₈ " Aluminum Panel Properties | 33 |
| 3" Steel Panel Properties | 34 |
| 3" Aluminum Panel Properties | 35 |
| Handling Material | |
| Receiving Material | 36 |
| General Handling | 36 |
| Mechanical Handling | 36 |
| Manual Handling | 37 |
| Storage | |
| General | 38 |
| Storage on Roof | 39 |
| Installation Concerns | 39 |
| Foot Traffic | 40 |
| Curb Installation | 40 |
| Field Cutting and Touch-up | |
| Field Cutting | 41 |
| Touch-up Paint | 41 |
| Design / Installation Considerations | |
| Fastener Installation Technique | 42 |
| Condition of Substructure | 42 |
| Ventilation | 43 |
| Insulation | 43 |
| System Expansion / Contraction | 44 |
| Selection of System Components | 44 |
| Factory Notching..... | 45 |
| Installation Strategies/Directions | 46 |
| Installation of Panel | |
| Installation of Eave Flashing | 47 |
| Installation of Rake Angle | 48 |
| Installing First Panel | 49 |
| Installing Panel Clips..... | 50 |
| Endlapping of Panel..... | 48-51 |

| SECTION | PAGE NO. |
|-------------------------------------|-----------------|
| Sidelapping of Panel | 53 |
| Termination of Panel | 54 |
| Seaming Panels | 55-56 |
| Panel Removal and Replacement..... | 56 |
| Installation Details | |
| Post Hung Gutter - Floating | 57 |
| Box Gutter - Floating..... | 58 |
| Eave Transition - Knee Cap | 59 |
| Eave - Floating..... | 60 |
| Valley - Floating..... | 61 |
| Endlap | 62 |
| Rake | 63 |
| Rakewall..... | 64 |
| Expansion Joint | 65 |
| Endwall - Fixed..... | 66 |
| Peak - Fixed..... | 67 |
| Ridge/Hip - Fixed | 68 |
| Post Hung Gutter - Fixed | 69 |
| Box Gutter -Fixed..... | 70 |
| Eave - Fixed..... | 71 |
| Drop Valley - Fixed..... | 72 |
| Endwall - Floating..... | 73 |
| Ridge/Hip - Floating | 74 |
| Z-Closure Installation..... | 75 |
| Hemming/Turn-Up Detail | 76 |
| Miscellaneous Details | 77 |
| Roof Penetrations | 77 |
| Installation Notes..... | 77 |
| Flashing Laps..... | 77 |
| Care and Maintenance | 78 |
| Panel Replacement..... | 79 |
| Notes | 80 |

This chart should be used to determine the specified angle.

| PROFILE/FLASHING | 1/4:12 | 1/2:12 | 1:12 | 2:12 | 3:12 | 4:12 | 5:12 | 6:12 | 7:12 | 8:12 |
|--|--------|--------|------|------|------|------|-------|-------|-------|-------|
| RIDGE SSR RIDGE VENTED RIDGE COVER | 178° | 175° | 170° | 161° | 152° | 143° | *135° | *127° | *120° | *113° |
| HIP VALLEY | 178° | 177° | 173° | 167° | 160° | 154° | 148° | 143° | 138° | 134° |
| EAVE, ROOF CLEAT EXTENDED EAVE SCULPTURED EAVE | 91° | 92° | 95° | 99° | 104° | 108° | 113° | 117° | 120° | 124° |
| SSR SCULPTURED HIGH SIDE EAVE | 99° | 98° | 95° | 91° | 86° | 82° | *77° | *73° | *70° | *66° |
| PEAK, ROOF CLEAT | 89° | 88° | 85° | 81° | 76° | 72° | 67° | 63° | 60° | 56° |
| PITCH BREAK HIGH SIDE PITCH BREAK | 91° | 92° | 95° | 99° | 104° | 108° | 113° | 117° | 120° | 124° |
| GUTTER DRIP BOX GUTTER | 91° | 92° | 95° | 99° | 104° | 108° | 113° | 117° | 120° | 124° |

T-ARMOR PEAK "A" DIMENSION

| | | | | | | | | | | |
|--|---------------------------------|---------------------------------|---------------------------------|---------------------------------|---------------------------------|---------------------------------|---------------------------------|---------------------------------|---------------------------------|---------------------------------|
| 2 ³ / ₈ " UTILITY SYSTEM | 5 ¹ / ₂ " | 5 ¹ / ₂ " | 5 ¹ / ₂ " | 5 ⁵ / ₈ " | 5 ⁵ / ₈ " | 5 ³ / ₄ " | 6" | 6 ¹ / ₈ " | 6 ³ / ₈ " | 6 ⁵ / ₈ " |
| 2 ³ / ₈ " LOW SYSTEM | 5 ⁷ / ₈ " | 5 ⁷ / ₈ " | 5 ⁷ / ₈ " | 6" | 6" | 6 ¹ / ₈ " | 6 ³ / ₈ " | 6 ¹ / ₂ " | 6 ⁷ / ₈ " | 7 ¹ / ₈ " |
| 2 ³ / ₈ " HIGH SYSTEM | 6 ⁷ / ₈ " | 6 ⁷ / ₈ " | 6 ⁷ / ₈ " | 7" | 7 ¹ / ₈ " | 7 ¹ / ₄ " | 7 ¹ / ₂ " | 7 ⁵ / ₈ " | 8" | 8 ¹ / ₄ " |
| 3" UTILITY SYSTEM | 6 ¹ / ₈ " | 6 ¹ / ₈ " | 6 ¹ / ₈ " | 6 ¹ / ₄ " | 6 ¹ / ₄ " | 6 ¹ / ₂ " | 6 ⁵ / ₈ " | 6 ⁷ / ₈ " | 7 ¹ / ₈ " | 7 ³ / ₈ " |
| 3" LOW SYSTEM | 6 ¹ / ₂ " | 6 ¹ / ₂ " | 6 ¹ / ₂ " | 6 ⁵ / ₈ " | 6 ³ / ₄ " | 6 ⁷ / ₈ " | 7" | 7 ¹ / ₄ " | 7 ¹ / ₂ " | 7 ³ / ₄ " |
| 3" HIGH SYSTEM | 7 ¹ / ₂ " | 7 ¹ / ₂ " | 7 ¹ / ₂ " | 7 ⁵ / ₈ " | 7 ³ / ₄ " | 7 ⁷ / ₈ " | 8 ¹ / ₈ " | 8 ³ / ₈ " | 8 ⁵ / ₈ " | 9" |

T-ARMOR EAVE "A" DIMENSION

| | | | | | | | | | | |
|----------------------|---------------------------------|---------------------------------|---------------------------------|---------------------------------|---------------------------------|---------------------------------|---------------------------------|---------------------------------|---------------------------------|---------------------------------|
| FLOATING SYSTEM | 3" | 3" | 3" | 3" | 3 ¹ / ₈ " | 3 ¹ / ₈ " | 3 ¹ / ₄ " | 3 ³ / ₈ " | 3 ¹ / ₂ " | 3 ⁵ / ₈ " |
| FIXED UTILITY SYSTEM | 3 ¹ / ₄ " | 3 ¹ / ₄ " | 3 ¹ / ₄ " | 3 ¹ / ₄ " | 3 ³ / ₈ " | 3 ³ / ₈ " | 3 ¹ / ₂ " | 3 ⁵ / ₈ " | 3 ³ / ₄ " | 3 ⁷ / ₈ " |
| FIXED LOW SYSTEM | 3 ³ / ₈ " | 3 ³ / ₈ " | 3 ³ / ₈ " | 3 ³ / ₈ " | 3 ¹ / ₂ " | 3 ¹ / ₂ " | 3 ⁵ / ₈ " | 3 ³ / ₄ " | 3 ⁷ / ₈ " | 4" |
| FIXED HIGH SYSTEM | 4 ³ / ₈ " | 4 ³ / ₈ " | 4 ³ / ₈ " | 4 ³ / ₈ " | 4 ¹ / ₂ " | 4 ⁵ / ₈ " | 4 ³ / ₄ " | 4 ⁷ / ₈ " | 5 ¹ / ₈ " | 5 ¹ / ₄ " |

ROOF CLEAT "A" DIMENSION

| | | | | | | | | | | |
|-------------|----|----|----|----|---------------------------------|---------------------------------|---------------------------------|---------------------------------|---------------------------------|---------------------------------|
| All SYSTEMS | 3" | 3" | 3" | 3" | 3 ¹ / ₈ " | 3 ¹ / ₈ " | 3 ¹ / ₄ " | 3 ³ / ₈ " | 3 ¹ / ₂ " | 3 ⁵ / ₈ " |
|-------------|----|----|----|----|---------------------------------|---------------------------------|---------------------------------|---------------------------------|---------------------------------|---------------------------------|

Note: "A" Dimension is 3" for Roof Cleat at Rake conditions for all slopes.

*Note: Metal Sales standard flashing dimensions may not accommodate all situations, please inquire about custom flashings for slopes 5:12 or greater.

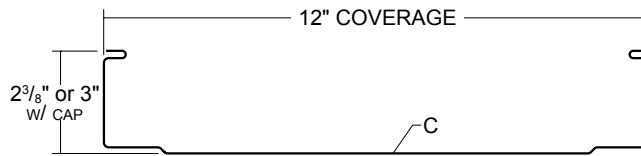

| GAUGES | 2 3/8" RIB HEIGHT | | | WEIGHT PER SQ. | GAUGES | 3" RIB HEIGHT | | | WEIGHT PER SQ. |
|---------|-------------------|----------|------------|----------------|---------|---------------|----------|------------|----------------|
| | ACG | PVDF | BARE ALUM. | | | ACG | PVDF | BARE ALUM. | |
| 24 GA | TA10141 | TA101XX | - | 172 lbs | 24 GA | TA10541 | TA105XX | - | 182 lbs |
| 22 GA | TA20141 | TA201XX | - | 218 lbs | 22 GA | TA20541 | TA205XX | - | 231 lbs |
| 20 GA | TA30141 | TA301XX | - | 261 lbs | 20 GA | TA30541 | TA305XX | - | 276 lbs |
| .032 AL | - | TA101XXA | TA10101A | 86 lbs | .032 AL | - | TA105XXA | TA10501A | 90 lbs |
| .040 AL | - | TA201XXA | TA20101A | 105 lbs | .040 AL | - | TA205XXA | TA20501A | 111 lbs |

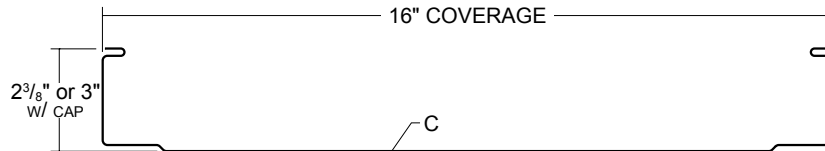

| GAUGES | 2 3/8" RIB HEIGHT | | | WEIGHT PER SQ. | GAUGES | 3" RIB HEIGHT | | | WEIGHT PER SQ. |
|---------|-------------------|----------|------------|----------------|---------|---------------|----------|------------|----------------|
| | ACG | PVDF | BARE ALUM. | | | ACG | PVDF | BARE ALUM. | |
| 24 GA | TA10241 | TA102XX | - | 152 lbs | 24 GA | TA10641 | TA106XX | - | 160 lbs |
| 22 GA | TA20241 | TA202XX | - | 194 lbs | 22 GA | TA20641 | TA206XX | - | 203 lbs |
| 20 GA | TA30241 | TA302XX | - | 232 lbs | 20 GA | TA30641 | TA306XX | - | 243 lbs |
| .032 AL | - | TA102XXA | TA10201A | 75 lbs | .032 AL | - | TA106XXA | TA10601A | 79 lbs |
| .040 AL | - | TA202XXA | TA20201A | 92 lbs | .040 AL | - | TA206XXA | TA20601A | 97 lbs |

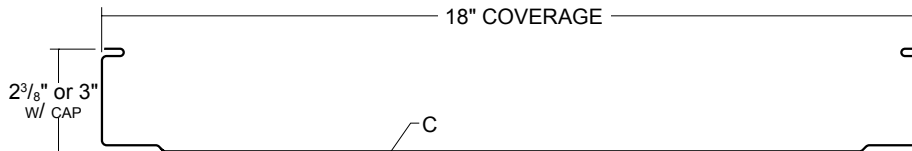

| GAUGES | 2 3/8" RIB HEIGHT | | | WEIGHT PER SQ. | GAUGES | 3" RIB HEIGHT | | | WEIGHT PER SQ. |
|---------|-------------------|----------|------------|----------------|---------|---------------|----------|------------|----------------|
| | ACG | PVDF | BARE ALUM. | | | ACG | PVDF | BARE ALUM. | |
| 24 GA | TA10341 | TA103XX | - | 146 lbs | 24 GA | TA10741 | TA107XX | - | 152 lbs |
| 22 GA | TA20341 | TA203XX | - | 186 lbs | 22 GA | TA20741 | TA207XX | - | 194 lbs |
| 20 GA | TA30341 | TA303XX | - | 222 lbs | 20 GA | TA30741 | TA307XX | - | 232 lbs |
| .032 AL | - | TA103XXA | TA10301A | 72 lbs | .032 AL | - | TA107XXA | TA10701A | 75 lbs |
| .040 AL | - | TA203XXA | TA20301A | 88 lbs | .040 AL | - | TA207XXA | TA20701A | 92 lbs |



| GAUGES | 2 3/8" RIB HEIGHT | | | WEIGHT PER SQ. | GAUGES | 3" RIB HEIGHT | | | WEIGHT PER SQ. |
|---------|-------------------|----------|------------|----------------|---------|---------------|----------|------------|----------------|
| | ACG | PVDF | BARE ALUM. | | | ACG | PVDF | BARE ALUM. | |
| 24 GA | TA10441 | TA104XX | - | 133 lbs | 24 GA | TA10841 | TA108XX | - | 138 lbs |
| 22 GA | TA20441 | TA204XX | - | 170 lbs | 22 GA | TA20841 | TA208XX | - | 176 lbs |
| 20 GA | TA30441 | TA304XX | - | 203 lbs | 20 GA | TA30841 | TA308XX | - | 211 lbs |
| .032 AL | - | TA104XXA | TA10401A | 65 lbs | .032 AL | - | TA108XXA | TA10801A | 67 lbs |
| .040 AL | - | TA204XXA | TA20401A | 80 lbs | .040 AL | - | TA208XXA | TA20801A | 83 lbs |

Panel weight includes the panel cap and panel clips at a 48" spacing.
3" rib height and 24" wide panels currently not available.

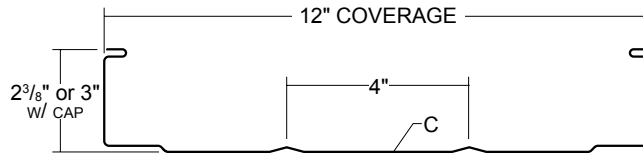

| GAUGES | 2 3/8" RIB HEIGHT | | | WEIGHT PER SQ. | GAUGES | 3" RIB HEIGHT | | | WEIGHT PER SQ. |
|---------|-------------------|----------|------------|----------------|---------|---------------|----------|------------|----------------|
| | ACG | PVDF | BARE ALUM. | | | ACG | PVDF | BARE ALUM. | |
| 24 GA | TA11141 | TA111XX | - | 172 lbs | 24 GA | TA11541 | TA115XX | - | 182 lbs |
| 22 GA | TA21141 | TA211XX | - | 218 lbs | 22 GA | TA21541 | TA215XX | - | 231 lbs |
| 20 GA | TA31141 | TA311XX | - | 261 lbs | 20 GA | TA31541 | TA315XX | - | 276 lbs |
| .032 AL | - | TA111XXA | TA11101A | 86 lbs | .032 AL | - | TA115XXA | TA11501A | 90 lbs |
| .040 AL | - | TA211XXA | TA21101A | 105 lbs | .040 AL | - | TA215XXA | TA21501A | 111 lbs |

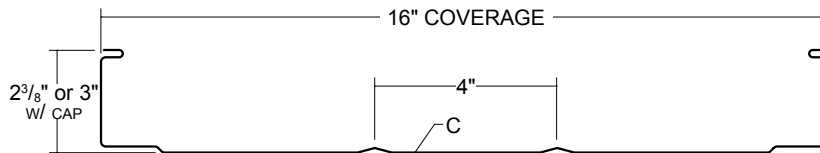

| GAUGES | 2 3/8" RIB HEIGHT | | | WEIGHT PER SQ. | GAUGES | 3" RIB HEIGHT | | | WEIGHT PER SQ. |
|---------|-------------------|----------|------------|----------------|---------|---------------|----------|------------|----------------|
| | ACG | PVDF | BARE ALUM. | | | ACG | PVDF | BARE ALUM. | |
| 24 GA | TA11241 | TA112XX | - | 152 lbs | 24 GA | TA11641 | TA116XX | - | 160 lbs |
| 22 GA | TA21241 | TA212XX | - | 194 lbs | 22 GA | TA21641 | TA216XX | - | 203 lbs |
| 20 GA | TA31241 | TA312XX | - | 232 lbs | 20 GA | TA31641 | TA316XX | - | 243 lbs |
| .032 AL | - | TA112XXA | TA11201A | 75 lbs | .032 AL | - | TA116XXA | TA11601A | 79 lbs |
| .040 AL | - | TA212XXA | TA11201A | 92 lbs | .040 AL | - | TA216XXA | TA21601A | 97 lbs |

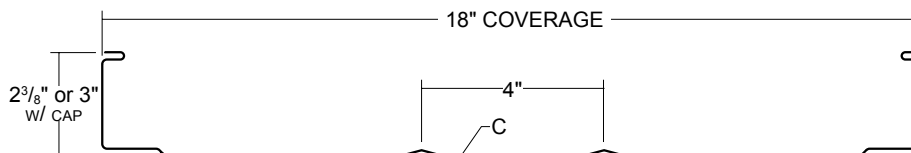

| GAUGES | 2 3/8" RIB HEIGHT | | | WEIGHT PER SQ. | GAUGES | 3" RIB HEIGHT | | | WEIGHT PER SQ. |
|---------|-------------------|----------|------------|----------------|---------|---------------|----------|------------|----------------|
| | ACG | PVDF | BARE ALUM. | | | ACG | PVDF | BARE ALUM. | |
| 24 GA | TA11341 | TA113XX | - | 146 lbs | 24 GA | TA11741 | TA117XX | - | 152 lbs |
| 22 GA | TA21341 | TA213XX | - | 186 lbs | 22 GA | TA21741 | TA217XX | - | 194 lbs |
| 20 GA | TA31341 | TA313XX | - | 222 lbs | 20 GA | TA31741 | TA317XX | - | 232 lbs |
| .032 AL | - | TA113XXA | TA11301A | 72 lbs | .032 AL | - | TA117XXA | TA11701A | 75 lbs |
| .040 AL | - | TA213XXA | TA21301A | 88 lbs | .040 AL | - | TA217XXA | TA21701A | 92 lbs |

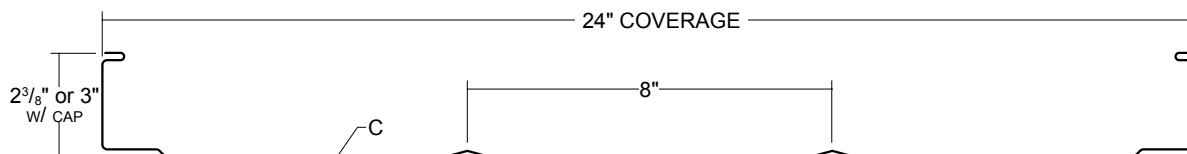

| GAUGES | 2 3/8" RIB HEIGHT | | | WEIGHT PER SQ. | GAUGES | 3" RIB HEIGHT | | | WEIGHT PER SQ. |
|---------|-------------------|----------|------------|----------------|---------|---------------|----------|------------|----------------|
| | ACG | PVDF | BARE ALUM. | | | ACG | PVDF | BARE ALUM. | |
| 24 GA | TA11441 | TA114XX | - | 133 lbs | 24 GA | TA11841 | TA118XX | - | 138 lbs |
| 22 GA | TA21441 | TA214XX | - | 170 lbs | 22 GA | TA21841 | TA218XX | - | 176 lbs |
| 20 GA | TA31441 | TA314XX | - | 203 lbs | 20 GA | TA31841 | TA318XX | - | 211 lbs |
| .032 AL | - | TA114XXA | TA11401A | 65 lbs | .032 AL | - | TA118XXA | TA11801A | 67 lbs |
| .040 AL | - | TA214XXA | TA21401A | 80 lbs | .040 AL | - | TA218XXA | TA21801A | 83 lbs |

Panel weight includes the panel cap and panel clips at a 48" spacing.
3" rib height and 24" wide panels currently not available.

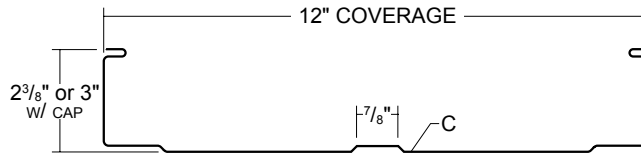

| GAUGES | 2 3/8" RIB HEIGHT | | | WEIGHT PER SQ. | GAUGES | 3" RIB HEIGHT | | | WEIGHT PER SQ. |
|---------|-------------------|----------|------------|----------------|---------|---------------|----------|------------|----------------|
| | ACG | PVDF | BARE ALUM. | | | ACG | PVDF | BARE ALUM. | |
| 24 GA | TA12141 | TA121XX | - | 172 lbs | 24 GA | TA12541 | TA125XX | - | 182 lbs |
| 22 GA | TA22141 | TA221XX | - | 218 lbs | 22 GA | TA22541 | TA225XX | - | 231 lbs |
| 20 GA | TA32141 | TA321XX | - | 261 lbs | 20 GA | TA32541 | TA325XX | - | 276 lbs |
| .032 AL | - | TA121XXA | TA12101A | 86 lbs | .032 AL | - | TA125XXA | TA12501A | 90 lbs |
| .040 AL | - | TA221XXA | TA22101A | 105 lbs | .040 AL | - | TA225XXA | TA22501A | 111 lbs |

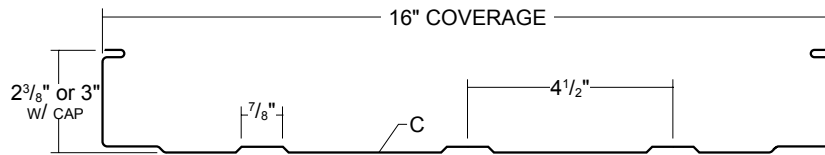

| GAUGES | 2 3/8" RIB HEIGHT | | | WEIGHT PER SQ. | GAUGES | 3" RIB HEIGHT | | | WEIGHT PER SQ. |
|---------|-------------------|----------|------------|----------------|---------|---------------|----------|------------|----------------|
| | ACG | PVDF | BARE ALUM. | | | ACG | PVDF | BARE ALUM. | |
| 24 GA | TA12241 | TA122XX | - | 152 lbs | 24 GA | TA12641 | TA126XX | - | 160 lbs |
| 22 GA | TA22241 | TA222XX | - | 194 lbs | 22 GA | TA22641 | TA226XX | - | 203 lbs |
| 20 GA | TA32241 | TA322XX | - | 232 lbs | 20 GA | TA32641 | TA326XX | - | 243 lbs |
| .032 AL | - | TA122XXA | TA12201A | 75 lbs | .032 AL | - | TA126XXA | TA12601A | 79 lbs |
| .040 AL | - | TA222XXA | TA22201A | 92 lbs | .040 AL | - | TA226XXA | TA22601A | 97 lbs |

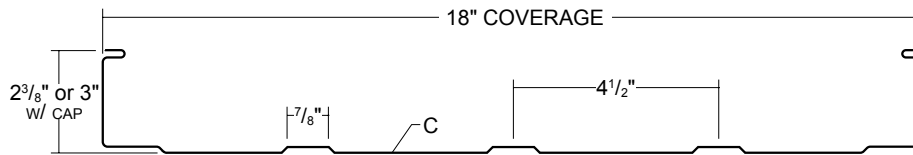

| GAUGES | 2 3/8" RIB HEIGHT | | | WEIGHT PER SQ. | GAUGES | 3" RIB HEIGHT | | | WEIGHT PER SQ. |
|---------|-------------------|----------|------------|----------------|---------|---------------|----------|------------|----------------|
| | ACG | PVDF | BARE ALUM. | | | ACG | PVDF | BARE ALUM. | |
| 24 GA | TA12341 | TA123XX | - | 146 lbs | 24 GA | TA12741 | TA127XX | - | 152 lbs |
| 22 GA | TA22341 | TA223XX | - | 186 lbs | 22 GA | TA22741 | TA227XX | - | 194 lbs |
| 20 GA | TA32341 | TA323XX | - | 222 lbs | 20 GA | TA32741 | TA327XX | - | 232 lbs |
| .032 AL | - | TA123XXA | TA12301A | 72 lbs | .032 AL | - | TA127XXA | TA12701A | 75 lbs |
| .040 AL | - | TA223XXA | TA22301A | 88 lbs | .040 AL | - | TA227XXA | TA22701A | 92 lbs |

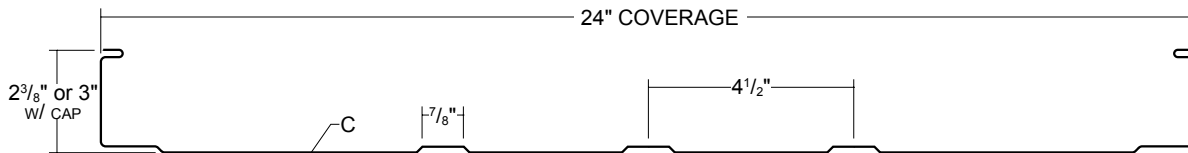

| GAUGES | 2 3/8" RIB HEIGHT | | | WEIGHT PER SQ. | GAUGES | 3" RIB HEIGHT | | | WEIGHT PER SQ. |
|---------|-------------------|----------|------------|----------------|---------|---------------|----------|------------|----------------|
| | ACG | PVDF | BARE ALUM. | | | ACG | PVDF | BARE ALUM. | |
| 24 GA | TA12441 | TA124XX | - | 133 lbs | 24 GA | TA12841 | TA128XX | - | 138 lbs |
| 22 GA | TA22441 | TA224XX | - | 170 lbs | 22 GA | TA22841 | TA228XX | - | 176 lbs |
| 20 GA | TA32441 | TA324XX | - | 203 lbs | 20 GA | TA32841 | TA328XX | - | 211 lbs |
| .032 AL | - | TA124XXA | TA12401A | 65 lbs | .032 AL | - | TA128XXA | TA12801A | 67 lbs |
| .040 AL | - | TA224XXA | TA22401A | 80 lbs | .040 AL | - | TA228XXA | TA22801A | 83 lbs |

Panel weight includes the panel cap and panel clips at a 48" spacing.
3" rib height and 24" wide panels currently not available.

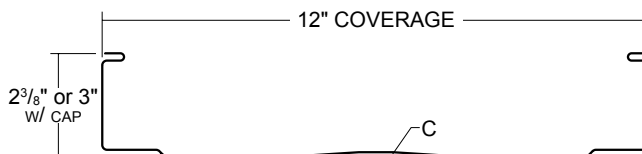

| GAUGES | 2 3/8" RIB HEIGHT | | | WEIGHT PER SQ. | GAUGES | 3" RIB HEIGHT | | | WEIGHT PER SQ. |
|---------|-------------------|----------|------------|----------------|---------|---------------|----------|------------|----------------|
| | ACG | PVDF | BARE ALUM. | | | ACG | PVDF | BARE ALUM. | |
| 24 GA | TA13141 | TA131XX | - | 172 lbs | 24 GA | TA13541 | TA135XX | - | 182 lbs |
| 22 GA | TA23141 | TA231XX | - | 218 lbs | 22 GA | TA23541 | TA235XX | - | 231 lbs |
| 20 GA | TA33141 | TA331XX | - | 261 lbs | 20 GA | TA33541 | TA335XX | - | 276 lbs |
| .032 AL | - | TA131XXA | TA13101A | 86 lbs | .032 AL | - | TA135XXA | TA13501A | 90 lbs |
| .040 AL | - | TA231XXA | TA23101A | 105 lbs | .040 AL | - | TA235XXA | TA23501A | 111 lbs |

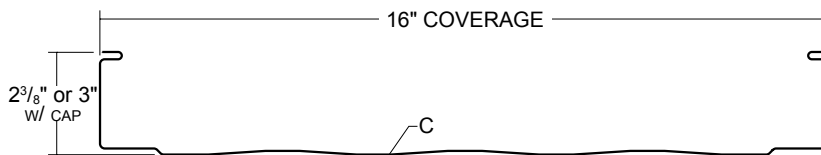

| GAUGES | 2 3/8" RIB HEIGHT | | | WEIGHT PER SQ. | GAUGES | 3" RIB HEIGHT | | | WEIGHT PER SQ. |
|---------|-------------------|----------|------------|----------------|---------|---------------|----------|------------|----------------|
| | ACG | PVDF | BARE ALUM. | | | ACG | PVDF | BARE ALUM. | |
| 24 GA | TA13241 | TA132XX | - | 152 lbs | 24 GA | TA13641 | TA136XX | - | 160 lbs |
| 22 GA | TA23241 | TA232XX | - | 194 lbs | 22 GA | TA23641 | TA236XX | - | 203 lbs |
| 20 GA | TA33241 | TA332XX | - | 232 lbs | 20 GA | TA33641 | TA336XX | - | 243 lbs |
| .032 AL | - | TA132XXA | TA13201A | 75 lbs | .032 AL | - | TA136XXA | TA13601A | 79 lbs |
| .040 AL | - | TA232XXA | TA23201A | 92 lbs | .040 AL | - | TA236XXA | TA23601A | 97 lbs |

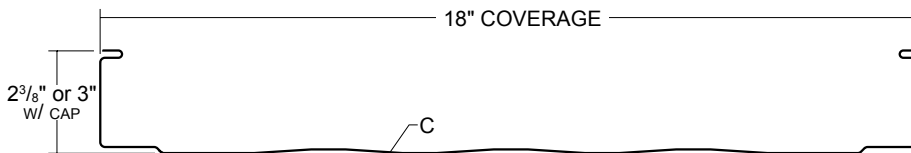

| GAUGES | 2 3/8" RIB HEIGHT | | | WEIGHT PER SQ. | GAUGES | 3" RIB HEIGHT | | | WEIGHT PER SQ. |
|---------|-------------------|----------|------------|----------------|---------|---------------|----------|------------|----------------|
| | ACG | PVDF | BARE ALUM. | | | ACG | PVDF | BARE ALUM. | |
| 24 GA | TA13341 | TA133XX | - | 146 lbs | 24 GA | TA13741 | TA137XX | - | 152 lbs |
| 22 GA | TA23341 | TA233XX | - | 186 lbs | 22 GA | TA23741 | TA237XX | - | 194 lbs |
| 20 GA | TA33341 | TA333XX | - | 222 lbs | 20 GA | TA33741 | TA337XX | - | 232 lbs |
| .032 AL | - | TA133XXA | TA13301A | 72 lbs | .032 AL | - | TA137XXA | TA13701A | 75 lbs |
| .040 AL | - | TA233XXA | TA23301A | 88 lbs | .040 AL | - | TA237XXA | TA23701A | 92 lbs |



| GAUGES | 2 3/8" RIB HEIGHT | | | WEIGHT PER SQ. | GAUGES | 3" RIB HEIGHT | | | WEIGHT PER SQ. |
|---------|-------------------|----------|------------|----------------|---------|---------------|----------|------------|----------------|
| | ACG | PVDF | BARE ALUM. | | | ACG | PVDF | BARE ALUM. | |
| 24 GA | TA13441 | TA134XX | - | 133 lbs | 24 GA | TA13841 | TA138XX | - | 138 lbs |
| 22 GA | TA23441 | TA234XX | - | 170 lbs | 22 GA | TA23841 | TA238XX | - | 176 lbs |
| 20 GA | TA33441 | TA334XX | - | 203 lbs | 20 GA | TA33841 | TA338XX | - | 211 lbs |
| .032 AL | - | TA134XXA | TA13401A | 65 lbs | .032 AL | - | TA138XXA | TA13801A | 67 lbs |
| .040 AL | - | TA234XXA | TA23401A | 80 lbs | .040 AL | - | TA238XXA | TA23801A | 83 lbs |

Panel weight includes the panel cap and panel clips at a 48" spacing.
3" rib height and 24" wide panels currently not available.

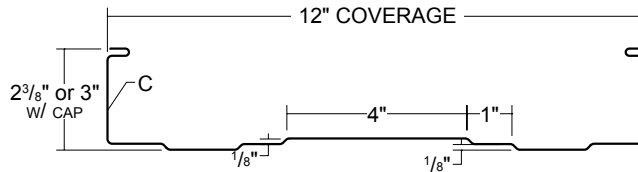

| GAUGES | 2 3/8" RIB HEIGHT | | | WEIGHT PER SQ. | GAUGES | 3" RIB HEIGHT | | | WEIGHT PER SQ. |
|---------|-------------------|----------|------------|----------------|---------|---------------|----------|------------|----------------|
| | ACG | PVDF | BARE ALUM. | | | ACG | PVDF | BARE ALUM. | |
| 24 GA | TA14141 | TA141XX | - | 172 lbs | 24 GA | TA14541 | TA145XX | - | 182 lbs |
| 22 GA | TA24141 | TA241XX | - | 218 lbs | 22 GA | TA24541 | TA245XX | - | 231 lbs |
| 20 GA | TA34141 | TA341XX | - | 261 lbs | 20 GA | TA34541 | TA345XX | - | 276 lbs |
| .032 AL | - | TA141XXA | TA14101A | 86 lbs | .032 AL | - | TA145XXA | TA14501A | 90 lbs |
| .040 AL | - | TA241XXA | TA24101A | 105 lbs | .040 AL | - | TA245XXA | TA24501A | 111 lbs |

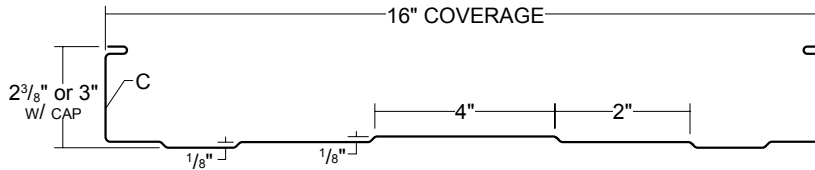

| GAUGES | 2 3/8" RIB HEIGHT | | | WEIGHT PER SQ. | GAUGES | 3" RIB HEIGHT | | | WEIGHT PER SQ. |
|---------|-------------------|----------|------------|----------------|---------|---------------|----------|------------|----------------|
| | ACG | PVDF | BARE ALUM. | | | ACG | PVDF | BARE ALUM. | |
| 24 GA | TA14241 | TA142XX | - | 152 lbs | 24 GA | TA14641 | TA146XX | - | 160 lbs |
| 22 GA | TA24241 | TA242XX | - | 194 lbs | 22 GA | TA24641 | TA246XX | - | 203 lbs |
| 20 GA | TA34241 | TA342XX | - | 232 lbs | 20 GA | TA34641 | TA346XX | - | 243 lbs |
| .032 AL | - | TA142XXA | TA14201A | 75 lbs | .032 AL | - | TA146XXA | TA14601A | 79 lbs |
| .040 AL | - | TA242XXA | TA24201A | 92 lbs | .040 AL | - | TA246XXA | TA24601A | 97 lbs |

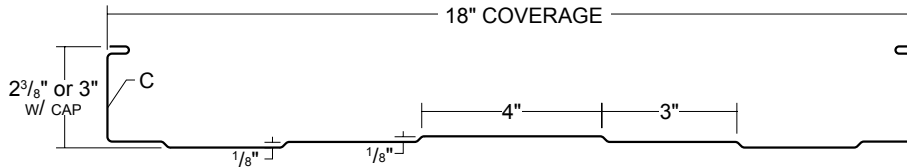

| GAUGES | 2 3/8" RIB HEIGHT | | | WEIGHT PER SQ. | GAUGES | 3" RIB HEIGHT | | | WEIGHT PER SQ. |
|---------|-------------------|----------|------------|----------------|---------|---------------|----------|------------|----------------|
| | ACG | PVDF | BARE ALUM. | | | ACG | PVDF | BARE ALUM. | |
| 24 GA | TA14341 | TA143XX | - | 146 lbs | 24 GA | TA14741 | TA147XX | - | 152 lbs |
| 22 GA | TA24341 | TA243XX | - | 186 lbs | 22 GA | TA24741 | TA247XX | - | 194 lbs |
| 20 GA | TA34341 | TA343XX | - | 222 lbs | 20 GA | TA34741 | TA347XX | - | 232 lbs |
| .032 AL | - | TA143XXA | TA14301A | 72 lbs | .032 AL | - | TA147XXA | TA14701A | 75 lbs |
| .040 AL | - | TA243XXA | TA24301A | 88 lbs | .040 AL | - | TA247XXA | TA24701A | 92 lbs |

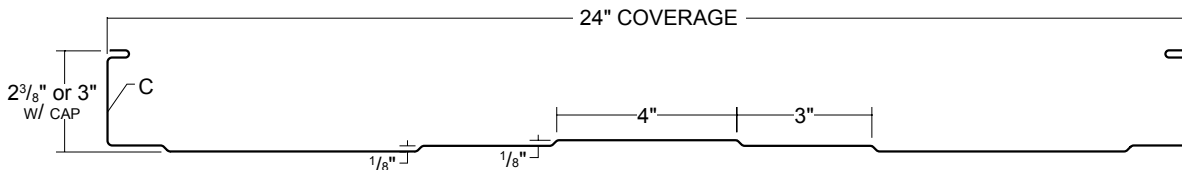

| GAUGES | 2 3/8" RIB HEIGHT | | | WEIGHT PER SQ. | GAUGES | 3" RIB HEIGHT | | | WEIGHT PER SQ. |
|---------|-------------------|----------|------------|----------------|---------|---------------|----------|------------|----------------|
| | ACG | PVDF | BARE ALUM. | | | ACG | PVDF | BARE ALUM. | |
| 24 GA | TA14441 | TA144XX | - | 133 lbs | 24 GA | TA14841 | TA148XX | - | 138 lbs |
| 22 GA | TA24441 | TA244XX | - | 170 lbs | 22 GA | TA24841 | TA248XX | - | 176 lbs |
| 20 GA | TA34441 | TA344XX | - | 203 lbs | 20 GA | TA34841 | TA348XX | - | 211 lbs |
| .032 AL | - | TA144XXA | TA14401A | 65 lbs | .032 AL | - | TA148XXA | TA14801A | 67 lbs |
| .040 AL | - | TA244XXA | TA24401A | 80 lbs | .040 AL | - | TA248XXA | TA24801A | 83 lbs |

Panel weight includes the panel cap and panel clips at a 48" spacing.
3" rib height and 24" wide panels currently not available.

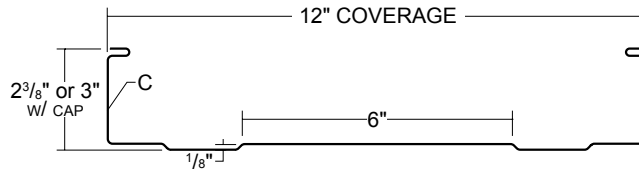

| 2 3/8" RIB HEIGHT | | | | | 3" RIB HEIGHT | | | | |
|-------------------|---------|----------|------------|----------------|---------------|---------|----------|------------|----------------|
| GAUGES | ACG | PVDF | BARE ALUM. | WEIGHT PER SQ. | GAUGES | ACG | PVDF | BARE ALUM. | WEIGHT PER SQ. |
| 24 GA | TA15141 | TA151XX | - | 172 lbs | 24 GA | TA15541 | TA155XX | - | 182 lbs |
| 22 GA | TA25141 | TA251XX | - | 218 lbs | 22 GA | TA25541 | TA255XX | - | 231 lbs |
| 20 GA | TA35141 | TA351XX | - | 261 lbs | 20 GA | TA35541 | TA355XX | - | 276 lbs |
| .032 AL | - | TA151XXA | TA15101A | 86 lbs | .032 AL | - | TA155XXA | TA15501A | 90 lbs |
| .040 AL | - | TA251XXA | TA25101A | 105 lbs | .040 AL | - | TA255XXA | TA25501A | 111 lbs |

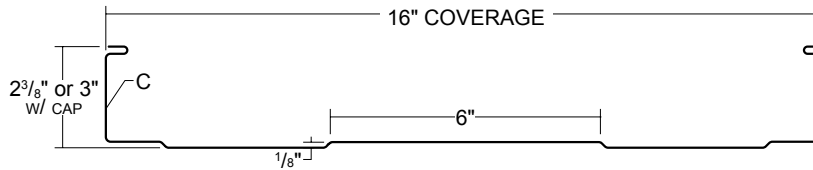

| 2 3/8" RIB HEIGHT | | | | | 3" RIB HEIGHT | | | | |
|-------------------|---------|----------|------------|----------------|---------------|---------|----------|------------|----------------|
| GAUGES | ACG | PVDF | BARE ALUM. | WEIGHT PER SQ. | GAUGES | ACG | PVDF | BARE ALUM. | WEIGHT PER SQ. |
| 24 GA | TA15241 | TA152XX | - | 152 lbs | 24 GA | TA15641 | TA156XX | - | 160 lbs |
| 22 GA | TA25241 | TA252XX | - | 194 lbs | 22 GA | TA25641 | TA256XX | - | 203 lbs |
| 20 GA | TA35241 | TA352XX | - | 232 lbs | 20 GA | TA35641 | TA356XX | - | 243 lbs |
| .032 AL | - | TA152XXA | TA15201A | 75 lbs | .032 AL | - | TA156XXA | TA15601A | 79 lbs |
| .040 AL | - | TA252XXA | TA25201A | 92 lbs | .040 AL | - | TA256XXA | TA25601A | 97 lbs |

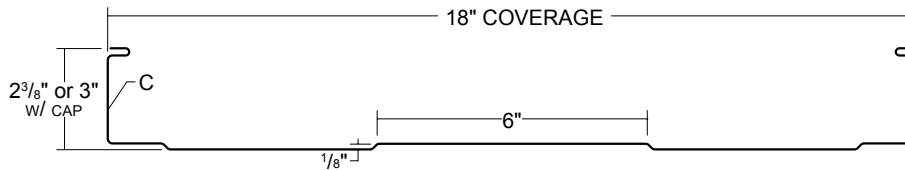

| 2 3/8" RIB HEIGHT | | | | | 3" RIB HEIGHT | | | | |
|-------------------|---------|----------|------------|----------------|---------------|---------|----------|------------|----------------|
| GAUGES | ACG | PVDF | BARE ALUM. | WEIGHT PER SQ. | GAUGES | ACG | PVDF | BARE ALUM. | WEIGHT PER SQ. |
| 24 GA | TA13341 | TA153XX | - | 146 lbs | 24 GA | TA13741 | TA157XX | - | 152 lbs |
| 22 GA | TA23341 | TA253XX | - | 186 lbs | 22 GA | TA23741 | TA257XX | - | 194 lbs |
| 20 GA | TA33341 | TA353XX | - | 222 lbs | 20 GA | TA33741 | TA357XX | - | 232 lbs |
| .032 AL | - | TA153XXA | TA15301A | 72 lbs | .032 AL | - | TA157XXA | TA15701A | 75 lbs |
| .040 AL | - | TA253XXA | TA25301A | 88 lbs | .040 AL | - | TA257XXA | TA25701A | 92 lbs |

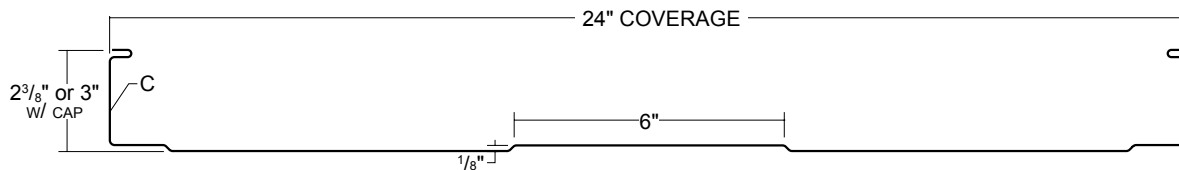

| 2 3/8" RIB HEIGHT | | | | | 3" RIB HEIGHT | | | | |
|-------------------|---------|----------|------------|----------------|---------------|---------|----------|------------|----------------|
| GAUGES | ACG | PVDF | BARE ALUM. | WEIGHT PER SQ. | GAUGES | ACG | PVDF | BARE ALUM. | WEIGHT PER SQ. |
| 24 GA | TA15441 | TA154XX | - | 133 lbs | 24 GA | TA15841 | TA158XX | - | 138 lbs |
| 22 GA | TA25441 | TA254XX | - | 170 lbs | 22 GA | TA25841 | TA258XX | - | 176 lbs |
| 20 GA | TA35441 | TA354XX | - | 203 lbs | 20 GA | TA35841 | TA358XX | - | 211 lbs |
| .032 AL | - | TA154XXA | TA15401A | 65 lbs | .032 AL | - | TA158XXA | TA15801A | 67 lbs |
| .040 AL | - | TA254XXA | TA25401A | 80 lbs | .040 AL | - | TA258XXA | TA25801A | 83 lbs |

Panel weight includes the panel cap and panel clips at a 48" spacing.
3" rib height and 24" wide panels currently not available.

T-ARMOR

ACCESSORY PROFILES



| T-ARMOR CAP | DESCRIPTION | GAUGE | PRODUCT NO. | FINISH | WT/FT |
|--|---------------------|-------|-------------|------------|----------|
| <p>Factory-Applied Sealant</p> <p>2"</p> | Mechanically Seamed | 24 | TAC01XX | PVDF/ACG | 0.16 lbs |
| | | 22 | TAC02XX | PVDF/ACG | 0.21 lbs |
| | | 20 | TAC03XX | PVDF/ACG | 0.26 lbs |
| | Mechanically Seamed | .032 | TAC01XXA | PVDF | 0.08 lbs |
| | | .040 | TAC02XXA | PVDF | 0.10 lbs |
| | | .032 | TAC0101A | Bare Alum. | 0.08 lbs |
| | | .040 | TAC0201A | Bare Alum. | 0.10 lbs |

Caps come in the same length as panels unless otherwise specified.

| T-ARMOR CLIP | SIZE | TYPE | PRODUCT NO. | CARTON QUANTITY | WT/ CARTON |
|---|---------------------------------|---|-------------|-----------------|------------|
| <p>Size</p> <p>3/4"</p> <p>3/4"</p> <p>3/4"</p> | 2 ³ / ₈ " | 2 ³ / ₈ " Utility | 3640900 | 100 pieces | 35 lbs |
| | 2 ³ / ₄ " | 2 ³ / ₈ " Low | 3641000 | 100 pieces | 40lbs |
| | 3 ³ / ₄ " | 2 ³ / ₈ " High | 3641200 | 100 pieces | 45 lbs |
| | 3" | 3" Utility | 3641100 | 100 pieces | 45 lbs |
| | 3 ³ / ₈ " | 3" Low | 3641300 | 100 pieces | 50 lbs |
| | 4 ³ / ₈ " | 3" High | 3641400 | 100 pieces | 55 lbs |

| T-ARMOR CONTINUOUS CLIP | GAUGE | FINISH | PRODUCT NO. | WT/FT | SIZE |
|-------------------------|-------|--------|-------------|----------|---------------------------------|
| <p>Size</p> | 24 | Varies | 5855199 | 0.48 lbs | 2 ³ / ₈ " |
| | 24 | Varies | 5855299 | 0.51 lbs | 2 ³ / ₄ " |
| | 24 | Varies | 5855399 | 0.59 lbs | 3 ³ / ₄ " |
| | 24 | Varies | 5855499 | 0.53 lbs | 3" |
| | 24 | Varies | 5855599 | 0.56 lbs | 3 ³ / ₈ " |
| | 24 | Varies | 5855699 | 0.64 lbs | 4 ³ / ₈ " |
| | 22 | Varies | 6055199 | 0.63 lbs | 2 ³ / ₈ " |
| | 22 | Varies | 6055299 | 0.66 lbs | 2 ³ / ₄ " |
| | 22 | Varies | 6055399 | 0.77 lbs | 3 ³ / ₄ " |
| | 22 | Varies | 6055499 | 0.69 lbs | 3" |
| | 22 | Varies | 6055599 | 0.73 lbs | 3 ³ / ₈ " |
| | 22 | Varies | 6055699 | 0.83 lbs | 4 ³ / ₈ " |

| THERMAL BLOCKS | SIZE | TYPE | PRODUCT NO. | WT/100 |
|----------------|-----------------|------------------|-------------|----------|
| | 3/8" x 3" x 12" | Polystyrene Foam | 4923777 | 1.25 lbs |
| | 3/8" x 3" x 16" | Polystyrene Foam | 4923787 | 1.50 lbs |
| | 3/8" x 3" x 18" | Polystyrene Foam | 4923775 | 1.75 lbs |
| | 3/8" x 3" x 24" | Polystyrene Foam | 4923776 | 2.00 lbs |
| | 1" x 3" x 12" | Polystyrene Foam | 4923778 | 2.75 lbs |
| | 1" x 3" x 16" | Polystyrene Foam | 4923760 | 3.00 lbs |
| | 1" x 3" x 18" | Polystyrene Foam | 4923770 | 3.50 lbs |
| | 1" x 3" x 24" | Polystyrene Foam | 4923779 | 3.75 lbs |

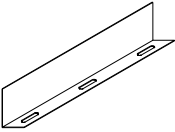
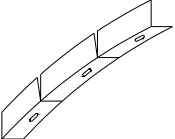
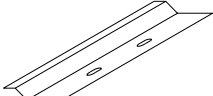
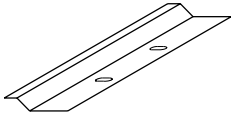
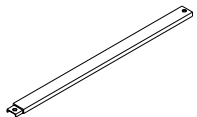
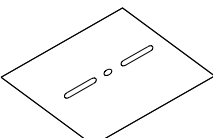
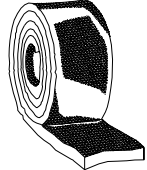
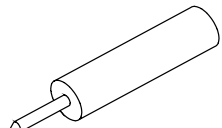
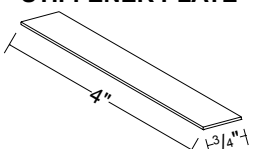
| | | | | | |
|---|---|-----------------|--------------------|------------------------|-------------------|
| FLOATING RAKE ANGLE  | SIZE | FINISH | LENGTH | PRODUCT NO. | WT |
| | 2 ⁵ / ₈ " x 16 Ga | Galvanized | 10'-0" | 4923810 | 10.7 lbs |
| | 3 ¹ / ₈ " x 16 Ga | Galvanized | 10'-0" | 4923815 | 10.9 lbs |
| | 3 ³ / ₄ " x 16 Ga | Galvanized | 10'-0" | 4923821 | 11.9 lbs |
| | 4 ¹ / ₈ " x 16 Ga | Galvanized | 10'-0" | 4923825 | 13.0 lbs |
| FLOATING RAKE ANGLE (CURVED APPLICATION)  | SIZE | FINISH | LENGTH | PRODUCT NO. | WT |
| | 2 ⁵ / ₈ " x 16 Ga | Galvanized | 10'-0" | 4923810C | 10.7 lbs |
| | 3 ¹ / ₈ " x 16 Ga | Galvanized | 10'-0" | 4923815C | 10.9 lbs |
| | 3 ³ / ₄ " x 16 Ga | Galvanized | 10'-0" | 4923821C | 11.9 lbs |
| | 4 ¹ / ₈ " x 16 Ga | Galvanized | 10'-0" | 4923825C | 13.0 lbs |
| EAVE PLATE  | SIZE | FINISH | TYPE | PRODUCT NO. | WT |
| | 1/4" x 16 Ga. | Galvanized | Utility 6'-0" | 4923835 | 4.1 lbs |
| | 3/8" x 16 Ga. | Galvanized | Low 10'-0" | 4923835 | 7.8 lbs |
| | 1 3/8" x 16 Ga. | Galvanized | High 10'-0" | 4923845 | 10.1 lbs |
| EAVE PLATE (CURVED APPLICATION)  | SIZE | FINISH | TYPE | PRODUCT NO. | WT |
| | 3/8" x 16 Ga. | Galvanized | Low 10'-0" | 4933800 | 12.7 lbs |
| | 1 3/8" x 16 Ga. | Galvanized | High 10'-0" | 4934800 | 14.1 lbs |
| BACK-UP CHANNEL  | SIZE | FINISH | LENGTH | PRODUCT NO. | WT |
| | 3" x 3/8" | Galvanized | 48" | 4923640 | 2.8 lbs |
| | 3" x 3/8" | Galvanized | 72" | 4923645 | 4.1 lbs |
| BEARING PLATE  | SIZE | FINISH | PRODUCT NO. | WT/100 | |
| | 4" x 5" x 20 Ga. | Galvanized | 4923886 | 30 lbs | |
| ENDLAP PAD  | SIZE | TYPE | PRODUCT NO. | WT/CARTON | |
| | 1 1/2" x 3/32" x 30' | Butyl | 6411999 | 27 lbs | |
| TUBE SEALANT  | SIZE | COLOR | PRODUCT NO. | CARTON QUANTITY | WT/ CARTON |
| | 10.3 oz | Urethane White | 6402830 | 30 cartridges | 19.3 lbs |
| | 10.3 oz | Urethane Bronze | 6402999 | 30 cartridges | 19.3 lbs |
| | 10.3 oz | Urethane Gray | 6402829 | 30 cartridges | 19.3 lbs |
| | 10.3 oz | Acrylic Clear | 6402800 | 30 cartridges | 19.3 lbs |
| STIFFENER PLATE  | SIZE | FINISH | GAUGE | PRODUCT NO. | WT/10 |
| | 3/4" x 4" | Galvanized | 16 | 3633900 | 0.55 lbs |

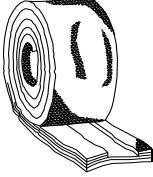
| DOUBLE BEAD TAPE SEALANT | SIZE | TYPE | PRODUCT NO. | CARTON QUANTITY | WT/ CARTON |
|---|--------------------|-------|-------------|-----------------|------------|
|  | 7/8" x 3/16" x 25' | Butyl | 6403899 | 20 rolls | 46.8 lbs |

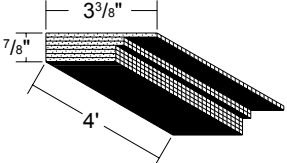
| VENT MATERIAL | SIZE | TYPE | PRODUCT NO. | CARTON QUANTITY | WT/ CARTON |
|---|---------------------|-------|-------------|-----------------|------------|
|  | 3 5/16" x 7/8" x 4' | Black | 6852406 | 24 pieces | 30.0 lbs |
| Use on roof with a 3:12 or greater slope. | | | | | |

| TOUCH-UP PAINT | TYPE | SIZE | PRODUCT NO. | WT |
|---|-----------------|--------------|-------------|----------|
|  | For PVDF finish | 2 oz. Bottle | 66005__ | 0.15 lbs |
| __ Represents color code designation. | | | | |

| ms-HT UNDERLAYMENT | TYPE | SIZE | PRODUCT NO. | WT/ ROLL |
|---|----------------|-----------------------------|-------------|----------|
|  | Peel-and-Stick | 36" x 66.67' (2 Sq Roll) | 4121200 | 44.0 lbs |

| UNDERLAYMENT PRIMER | SIZE | PRODUCT NO. | WT/ ROLL |
|---|-----------|-------------|----------|
|  | 5 Gallon* | 6600000 | 42.0 lbs |
| Coverage is 100 to 125 ft ² per gallon depending on substrate. | | | |

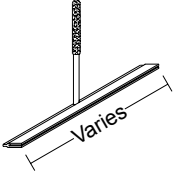
| HEMMING/TURN-UP TOOL | TYPE | SIZE | PRODUCT NO. | WT/100 |
|---|-----------|------|-------------|---------|
|  | 24" Panel | 20" | 6560102 | 3.3 lbs |
| | 18" Panel | 17" | 6560122 | 2.9 lbs |
| | 16" Panel | 15" | 6560132 | 2.6 lbs |
| | 12" Panel | 11" | 6560142 | 2.1 lbs |
| Used for bending lower end of the metal panel to accept Offset Cleat flashing for concealed fastener application or for turning up the end of the panel at the high side. | | | | |

| POST HUNG GUTTER HANGER | SIZE | FINISH | TYPE | PRODUCT NO. | WT |
|---|-------------|------------|------|-------------|---------|
|  | 6" x 16 Ga. | Galvanized | Galv | 3633800 | 0.2 lbs |

RUBBER ROOF DECK FLASHINGS

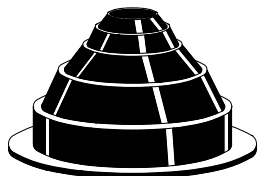

| TYPE | SIZE | BASE DIAM. | PRODUCT NO. | WT |
|--------|------------|-----------------|-------------|----------|
| Rubber | #1 Flasher | 1/4" - 2" | 68501__* | 3.0 lbs |
| Rubber | #2 Flasher | 1 3/4" - 3 1/4" | 68502__* | 3.0 lbs |
| Rubber | #3 Flasher | 1/4" - 5" | 68503__* | 3.0 lbs |
| Rubber | #4 Flasher | 3" - 6 1/4" | 68504__* | 3.0 lbs |
| Rubber | #5 Flasher | 4 1/4" - 7 1/2" | 68505__* | 5.0 lbs |
| Rubber | #6 Flasher | 5" - 9" | 68506__* | 9.0 lbs |
| Rubber | #7 Flasher | 6" - 11" | 68507__* | 11.0 lbs |
| Rubber | #8 Flasher | 7" - 13" | 68508__* | 13.0 lbs |
| Rubber | #9 Flasher | 10" - 19" | 68509__* | 13.0 lbs |

Special order colors: 93=Brown; 94=Green; 95=Red; 96=Blue; 97=White; 98=Grey; 99=Black

ROUND

Rubber Roof Jack Round Base

| | | | | |
|-------------|----------------|-----------------|---------|----------|
| HT Silicone | #1 Flasher | 1/4" - 2" | 6850011 | 3.0 lbs |
| HT Silicone | #2 Flasher | 1 3/4" - 3 1/4" | 6850012 | 3.0 lbs |
| HT Silicone | #3 Flasher | 1/4" - 5" | 6850013 | 3.0 lbs |
| HT Silicone | #4 Flasher | 3" - 6 1/4" | 6850014 | 3.0 lbs |
| HT Silicone | #5 Flasher | 4 1/4" - 7 1/2" | 6850015 | 5.0 lbs |
| HT Silicone | #6 Flasher | 5" - 9" | 6850016 | 9.0 lbs |
| HT Silicone | #7 Flasher | 6" - 11" | 6850017 | 11.0 lbs |
| HT Silicone | #8 Flasher | 7" - 13" | 6850018 | 13.0 lbs |
| HT Silicone | #9 Flasher | 10" - 19" | 6850019 | 13.0 lbs |
| Retrofit HT | #1 Masterflash | 1/4" - 2" | 6850060 | 4.0 lbs |
| Retrofit HT | #2 Masterflash | 1 1/4" - 3" | 6850061 | 4.0 lbs |
| Retrofit HT | #3 Masterflash | 1/4" - 4" | 6850062 | 4.0 lbs |

GRAY ROUND RETRO ROOF JACK

| | | | | |
|-------------------|----------------|-------------|---------|---------|
| Retrofit E.P.D.M. | #1 Masterflash | 1/4" - 2" | 6850070 | 4.0 lbs |
| Retrofit E.P.D.M. | #2 Masterflash | 1 1/4" - 3" | 6850071 | 4.0 lbs |
| Retrofit E.P.D.M. | #3 Masterflash | 1/4" - 4" | 6850072 | 4.0 lbs |

BLACK ROUND RETRO ROOF JACK

| | | | | |
|-------------------|----------------|-------------|---------|---------|
| Retrofit E.P.D.M. | #1 Masterflash | 1/4" - 2" | 6850073 | 4.0 lbs |
| Retrofit E.P.D.M. | #2 Masterflash | 1 1/4" - 3" | 6850074 | 4.0 lbs |
| Retrofit E.P.D.M. | #3 Masterflash | 1/4" - 4" | 6850075 | 4.0 lbs |

SQUARE

Retro Roof Jack Square Base

BLACK SQUARE RETRO ROOF JACK

| | | | | |
|-------------------|----------------|-------------|---------|---------|
| Retrofit E.P.D.M. | #1 Masterflash | 1/4" - 2" | 6850046 | 4.0 lbs |
| Retrofit E.P.D.M. | #2 Masterflash | 1 1/4" - 3" | 6850047 | 4.0 lbs |
| Retrofit E.P.D.M. | #3 Masterflash | 1/4" - 4" | 6850048 | 4.0 lbs |

Kit includes: membrane fasteners, termination strips, splice material and sealant. (Deck Flashing temperature range is -65° to +250°; HT Deck Flashing temperature range is -100° to +450°).

| VENTED RIDGE COVER | GAUGE | FINISH | PRODUCT NO. | WT | LENGTH | |
|--------------------|------------------------|--------|-------------|----------|--------|--|
| | 24 | ACG | 5701341 | 13.3 lbs | 10'-2" | |
| | 24 | ACG | 5701541 | 26.5 lbs | 20'-3" | |
| | 24 | PVDF | 58013__ | 13.3 lbs | 10'-2" | |
| | 24 | PVDF | 58015__ | 26.5 lbs | 20'-3" | |
| | * See chart on page 6. | | | | | |

| VENT DRIP | GAUGE | FINISH | PRODUCT NO. | WT | LENGTH |
|-----------|-------|--------|-------------|---------|--------|
| | 24 | ACG | 5701741 | 3.8 lbs | 10'-2" |
| | 24 | PVDF | 58017__ | 3.8 lbs | 10'-2" |

| SSR RIDGE | GAUGE | FINISH | PRODUCT NO. | WT | LENGTH | |
|-----------|------------------------|--------|-------------|----------|--------|--|
| | 24 | ACG | 5775141 | 14.7 lbs | 10'-2" | |
| | 24 | ACG | 5775341 | 29.7 lbs | 20'-3" | |
| | 24 | PVDF | 58751__ | 14.7 lbs | 10'-2" | |
| | 24 | PVDF | 58753__ | 29.7 lbs | 20'-3" | |
| | * See chart on page 6. | | | | | |

| 7" RIDGE/HIP COVER | GAUGE | FINISH | PRODUCT NO. | WT | LENGTH | |
|--------------------|------------------------|--------|-------------|----------|--------|--|
| | 24 | ACG | 5854441 | 12.7 lbs | 10'-2" | |
| | 24 | ACG | 5855441 | 25.4 lbs | 20'-3" | |
| | 24 | PVDF | 58544__ | 12.7 lbs | 10'-2" | |
| | 24 | PVDF | 58554__ | 25.4 lbs | 20'-3" | |
| | * See chart on page 6. | | | | | |

| EXPANSION JOINT | GAUGE | FINISH | PRODUCT NO. | WT | LENGTH |
|-----------------|-------|--------|-------------|----------|--------|
| | 24 | ACG | 6372241 | 14.7 lbs | 10'-2" |
| | 24 | ACG | 6372341 | 29.3 lbs | 20'-3" |
| | 24 | PVDF | 64722__ | 14.7 lbs | 10'-2" |
| | 24 | PVDF | 64723__ | 29.3 lbs | 20'-3" |

| 15" VALLEY | GAUGE | FINISH | PRODUCT NO. | WT | LENGTH | |
|------------|------------------------|--------|-------------|----------|--------|--|
| | 24 | ACG | 5852841 | 15.9 lbs | 10'-2" | |
| | 24 | ACG | 5853841 | 31.7 lbs | 20'-3" | |
| | 24 | PVDF | 58528__ | 15.9 lbs | 10'-2" | |
| | 24 | PVDF | 58538__ | 31.7 lbs | 20'-3" | |
| | * See chart on page 6. | | | | | |

| 4.5" DROP VALLEY | GAUGE | FINISH | PRODUCT NO. | WT | LENGTH | | | | | | | | | |
|---|-----------------------|--------|-------------|----------|--------|--------|------|--------|--------|----------------------|--|--|--|--|
| <table border="1" style="margin-top: 10px;"> <thead> <tr> <th>SYSTEM</th> <th>A</th> <th>B</th> </tr> </thead> <tbody> <tr> <td>LOW</td> <td>3/4"</td> <td>4 3/4"</td> </tr> <tr> <td>HIGH</td> <td>2 3/4"</td> <td>2 3/4"</td> </tr> </tbody> </table> | SYSTEM | A | B | LOW | 3/4" | 4 3/4" | HIGH | 2 3/4" | 2 3/4" | Low 4.5" Drop Valley | | | | |
| | SYSTEM | A | B | | | | | | | | | | | |
| | LOW | 3/4" | 4 3/4" | | | | | | | | | | | |
| | HIGH | 2 3/4" | 2 3/4" | | | | | | | | | | | |
| | 24 | ACG | 5781741 | 19.1 lbs | 10'-2" | | | | | | | | | |
| | 24 | ACG | 5781941 | 38.0 lbs | 20'-3" | | | | | | | | | |
| | 24 | PVDF | 58817__ | 19.1 lbs | 10'-2" | | | | | | | | | |
| | 24 | PVDF | 58819__ | 38.0 lbs | 20'-3" | | | | | | | | | |
| | High 4.5" Drop Valley | | | | | | | | | | | | | |
| | 24 | ACG | 5782341 | 19.1 lbs | 10'-2" | | | | | | | | | |
| | 24 | ACG | 5782541 | 38.0 lbs | 20'-3" | | | | | | | | | |
| | 24 | PVDF | 58823__ | 19.1 lbs | 10'-2" | | | | | | | | | |
| | 24 | PVDF | 58825__ | 38.0 lbs | 20'-3" | | | | | | | | | |
| | * See chart on page 6 | | | | | | | | | | | | | |

9" DROP VALLEY

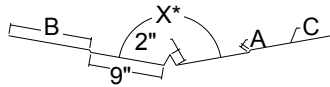

| SYSTEM | A | B |
|--------|--------|----|
| LOW | 3/4" | 5" |
| HIGH | 2 3/4" | 3" |

| GAUGE | FINISH | PRODUCT NO. | WT | LENGTH |
|---------------------|--------|-------------|----------|--------|
| Low 9" Drop Valley | | | | |
| 24 | ACG | 5786341 | 26.7 lbs | 10'-2" |
| 24 | ACG | 5786441 | 53.1 lbs | 20'-3" |
| 24 | PVDF | 58863__ | 26.7 lbs | 10'-2" |
| 24 | PVDF | 58864__ | 53.1 lbs | 20'-3" |
| High 9" Drop Valley | | | | |
| 24 | ACG | 5786741 | 26.7 lbs | 10'-2" |
| 24 | ACG | 5786841 | 53.1 lbs | 20'-3" |
| 24 | PVDF | 58867__ | 26.7 lbs | 10'-2" |
| 24 | PVDF | 58868__ | 53.1 lbs | 20'-3" |

* See chart on page 6.

T-ARMOR PEAK

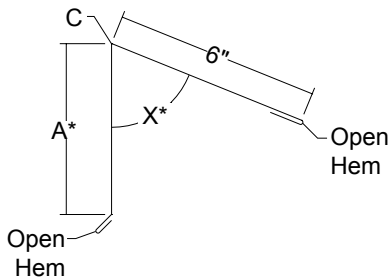

* "A" dimension will vary per slope
See chart on page 6.
Weight varies.

| GAUGE | FINISH | PRODUCT NO. | DESCRIPTION | LENGTH |
|-------|--------|-------------|----------------|--------|
| 24 | PVDF | 58551__ | 2 3/8" Utility | 10'-2" |
| 24 | ACG | 5855141 | 2 3/8" Utility | 10'-2" |
| 24 | PVDF | 58522__ | 2 3/8" Low | 10'-2" |
| 24 | ACG | 5852241 | 2 3/8" Low | 10'-2" |
| 24 | PVDF | 58523__ | 2 3/8" High | 10'-2" |
| 24 | ACG | 5852341 | 2 3/8" High | 10'-2" |
| 24 | PVDF | 58524__ | 3" Utility | 10'-2" |
| 24 | ACG | 5852441 | 3" Utility | 10'-2" |
| 24 | PVDF | 58525__ | 3" Low | 10'-2" |
| 24 | ACG | 5852541 | 3" Low | 10'-2" |
| 24 | PVDF | 58526__ | 3" High | 10'-2" |
| 24 | ACG | 5852641 | 3" High | 10'-2" |

SSR SCULPTURED HIGH SIDE EAVE

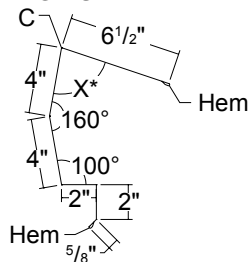

* See chart on page 6.

| GAUGE | FINISH | PRODUCT NO. | WT | LENGTH |
|-------|--------|-------------|----------|--------|
| 24 | ACG | 5776941 | 15.9 lbs | 10'-2" |
| 24 | ACG | 5777141 | 31.7 lbs | 20'-3" |
| 24 | PVDF | 58769__ | 15.9 lbs | 10'-2" |
| 24 | PVDF | 58771__ | 31.7 lbs | 20'-3" |

T-ARMOR EAVE

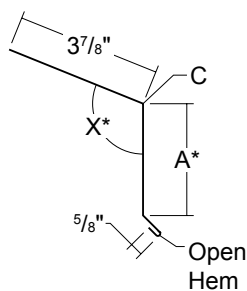

* "A" dimension will vary per slope.
See chart on page 6.

| GAUGE | FINISH | PRODUCT NO. | WT | LENGTH |
|-------|--------|-------------|---------|--------|
| 24 | ACG | 5706541 | 6.3 lbs | 10'-2" |
| 24 | PVDF | 58065__ | 6.3 lbs | 10'-2" |

Weight Varies with slope.

T-ARMOR SCULPTURED EAVE

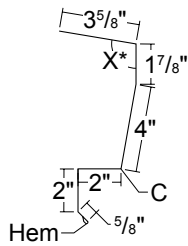

| GAUGE | FINISH | PRODUCT NO. | WT | LENGTH |
|-------|--------|-------------|----------|--------|
| 24 | ACG | 5783541 | 11.5 lbs | 10'-2" |
| 24 | ACG | 5783741 | 23.0 lbs | 20'-3" |
| 24 | PVDF | 58835__ | 11.5 lbs | 10'-2" |
| 24 | PVDF | 58837__ | 23.0 lbs | 20'-3" |

* See chart on page 6.

T-ARMOR RAKE

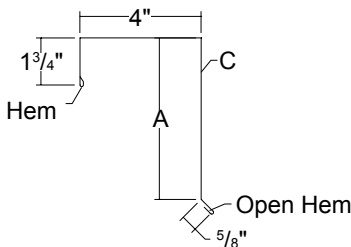

| 2 3/8" Panel | | 3" Panel | |
|--------------|--------|----------|--------|
| System | A | System | A |
| Utility | 5 1/2" | Utility | 6 1/8" |
| Low | 5 7/8" | Low | 6 1/2" |
| High | 6 7/8" | High | 7 1/2" |

Weight Varies with size.

| GAUGE | FINISH | PRODUCT NO. | DESCRIPTION | LENGTH |
|-------|--------|-------------|----------------|--------|
| 24 | PVDF | 58537__ | 2 3/8" Utility | 10'-2" |
| 24 | ACG | 5853741 | 2 3/8" Utility | 10'-2" |
| 24 | PVDF | 58538__ | 2 3/8" Low | 10'-2" |
| 24 | ACG | 5853841 | 2 3/8" Low | 10'-2" |
| 24 | PVDF | 58539__ | 2 3/8" High | 10'-2" |
| 24 | ACG | 5853941 | 2 3/8" High | 10'-2" |
| 24 | PVDF | 58540__ | 3" Utility | 10'-2" |
| 24 | ACG | 5854041 | 3" Utility | 10'-2" |
| 24 | PVDF | 58541__ | 3" Low | 10'-2" |
| 24 | ACG | 5854141 | 3" Low | 10'-2" |
| 24 | PVDF | 58542__ | 3" High | 10'-2" |
| 24 | ACG | 5854241 | 3" High | 10'-2" |

OFFSET RAKE SLIDE

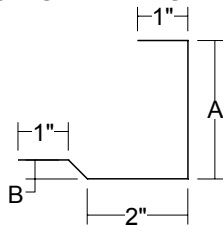

| 2 3/8" Panel | | | 3" Panel | | |
|--------------|--------|--------|----------|--------|--------|
| System | A | B | System | A | B |
| Utility | 2 5/8" | 1/4" | Utility | 3 1/4" | 1/4" |
| Low | 2 7/8" | 3/8" | Low | 3 1/2" | 3/8" |
| High | 3 7/8" | 1 3/8" | High | 4 1/2" | 1 3/8" |

| GAUGE | PRODUCT NO. | DESCRIPTION | LENGTH | WT |
|-------|-------------|----------------|--------|---------|
| 24 | 5853199 | 2 3/8" Utility | 10'-2" | 5.9 lbs |
| 24 | 5853299 | 2 3/8" Low | 10'-2" | 6.1 lbs |
| 24 | 5853399 | 2 3/8" High | 10'-2" | 7.4 lbs |
| 24 | 5853499 | 3" Utility | 10'-2" | 6.4 lbs |
| 24 | 5853599 | 3" Low | 10'-2" | 6.6 lbs |
| 24 | 5853699 | 3" High | 10'-2" | 7.9 lbs |

Supplied in various colors.

SSR RAKE SLIDE

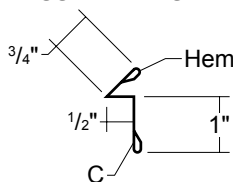

| GAUGE | FINISH | PRODUCT NO. | WT | LENGTH |
|-------|--------|-------------|---------|--------|
| 24 | ACG | 5776541 | 2.4 lbs | 10'-2" |
| 24 | PVDF | 58765__ | 2.4 lbs | 10'-2" |

STARTER

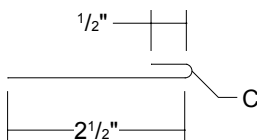

| GAUGE | FINISH | PRODUCT NO. | WT | LENGTH |
|-------|--------|-------------|---------|--------|
| 24 | ACG | 5706241 | 2.5 lbs | 10'-2" |
| 24 | PVDF | 58062__ | 2.5 lbs | 10'-2" |

| | GAUGE | FINISH | PRODUCT NO. | WT | LENGTH |
|--|------------------------|--------|-------------|----------|--------|
| | 24 | ACG | 5775941 | 15.8 lbs | 10'-2" |
| | 24 | ACG | 5776141 | 31.5 lbs | 20'-3" |
| | 24 | PVDF | 58759__ | 15.8 lbs | 10'-2" |
| | 24 | PVDF | 58761__ | 31.5 lbs | 20'-3" |
| | Closed Hem | | | | |
| | Hem | | | | |
| | 24 | ACG | 5776341 | 0.2 lbs | |
| | 24 | PVDF | 58763__ | 0.2 lbs | |
| | 24 | ACG | 5855641 | 8.6 lbs | 10'-2" |
| | 24 | ACG | 5855841 | 17.2 lbs | 20'-3" |
| | 24 | PVDF | 58556__ | 8.6 lbs | 10'-2" |
| | 24 | PVDF | 58558__ | 17.2 lbs | 20'-3" |
| | Open Hem | | | | |
| | Closed Hem | | | | |
| | 24 | ACG | 5777341 | 11.3 lbs | 10'-2" |
| | 24 | ACG | 5777541 | 22.6 lbs | 20'-3" |
| | 24 | PVDF | 58773__ | 11.3 lbs | 10'-2" |
| | 24 | PVDF | 58775__ | 22.6 lbs | 20'-3" |
| | Open Hem | | | | |
| | * See chart on page 6. | | | | |
| | 24 | ACG | 5705241 | 3.1 lbs | 10'-2" |
| | 24 | PVDF | 58052__ | 3.1 lbs | 10'-2" |
| | 24 | ACG | 5705441 | 3.2 lbs | 10'-2" |
| | 24 | PVDF | 58054__ | 3.2 lbs | 10'-2" |

| BOX GUTTER | GAUGE | FINISH | PRODUCT NO. | WT | LENGTH | |
|------------|------------------------|--------|-------------|----------|--------|--|
| | 24 | ACG | 5707741 | 16.9 lbs | 10'-2" | |
| | 24 | ACG | 5707941 | 33.7 lbs | 20'-3" | |
| | 24 | PVDF | 58077__ | 16.9 lbs | 10'-2" | |
| | 24 | PVDF | 58079__ | 33.7 lbs | 20'-3" | |
| | * See chart on page 6. | | | | | |

| POST HUNG GUTTER | GAUGE | FINISH | PRODUCT NO. | WT | LENGTH |
|------------------|-------|--------|-------------|----------|--------|
| | 24 | ACG | 5853041 | 15.1 lbs | 10'-2" |
| | 24 | ACG | 5853141 | 30.0 lbs | 20'-3" |
| | 24 | PVDF | 58530__ | 15.1 lbs | 10'-2" |
| | 24 | PVDF | 58531__ | 30.0 lbs | 20'-3" |

| BOX GUTTER END | GAUGE | FINISH | PRODUCT NO. | WT |
|----------------|-------|--------|-----------------------------------|---------|
| | 24 | ACG | 5708141 (Left) 5708241 (Right) | 0.3 lbs |
| | 24 | PVDF | 58081__ (Left) 58082__ (Right) | 0.3 lbs |

| POST HUNG GUTTER END | GAUGE | FINISH | PRODUCT NO. | WT |
|----------------------|-------|--------|-----------------------------------|---------|
| | 24 | ACG | 5848141 (Left) 5848241 (Right) | 0.3 lbs |
| | 24 | PVDF | 58481__ (Left) 58482__ (Right) | 0.3 lbs |

| SSR GUTTER DRIP | GAUGE | FINISH | PRODUCT NO. | WT | LENGTH |
|-----------------|------------------------|--------|-------------|---------|--------|
| | 24 | ACG | 5778141 | 6.4 lbs | 10'-2" |
| | 24 | PVDF | 58781__ | 6.4 lbs | 10'-2" |
| | * See chart on page 6. | | | | |

| UNIVERSAL GUTTER/ DOWNSPOUT STRAP | GAUGE | FINISH | PRODUCT NO. | WT | LENGTH |
|--------------------------------------|-------|--------|-------------|---------|--------|
| | 24 | ACG | 5709241 | .36 lbs | 1'-4" |
| | 24 | PVDF | 58092__ | .36 lbs | 1'-4" |

| 4" x 6" DOWNSPOUT | GAUGE | FINISH | PRODUCT NO. | WT | LENGTH |
|-------------------|-------|--------|-------------|----------|--------|
| | 24 | ACG | 5709841 | 16.7 lbs | 10'-2" |
| | 24 | ACG | 5710141 | 33.3 lbs | 20'-3" |
| | 24 | PVDF | 58098__ | 16.7 lbs | 10'-2" |
| | 24 | PVDF | 58101__ | 33.3 lbs | 20'-3" |

| 3 1/2" x 4" DOWNSPOUT | GAUGE | FINISH | PRODUCT NO. | WT | LENGTH |
|-----------------------|-------|--------|-------------|----------|--------|
| | 24 | ACG | 5709441 | 12.7 lbs | 10'-2" |
| | 24 | ACG | 5709741 | 25.4 lbs | 20'-3" |
| | 24 | PVDF | 58094__ | 12.7 lbs | 10'-2" |
| | 24 | PVDF | 58097__ | 25.4 lbs | 20'-3" |

| 4" DOWNSPOUT BRACKET | GAUGE | FINISH | PRODUCT NO. | WT |
|----------------------|-------|--------|-------------|---------|
| | 24 | ACG | 5711041 | 0.1 lbs |
| | 24 | PVDF | 58110__ | 0.1 lbs |

| 6" DOWNSPOUT BRACKET | GAUGE | FINISH | PRODUCT NO. | WT |
|----------------------|-------|--------|-------------|---------|
| | 24 | ACG | 5711241 | 0.1 lbs |
| | 24 | PVDF | 58112__ | 0.1 lbs |

| ELBOWS | GAUGE | FINISH | PRODUCT NO. | WT |
|----------------------------|-----------------------|--------|-------------|---------|
| 3 1/2" x 4" ELBOWS (D x W) | | | | |
| | 95 DEGREE | | | |
| | 24 | ACG | 5710241 | 2.3 lbs |
| | 24 | PVDF | 58102__ | 2.3 lbs |
| | 45 DEGREE | | | |
| | 24 | ACG | 5710641 | 2.3 lbs |
| | 24 | PVDF | 58106__ | 2.3 lbs |
| | 4"x 6" ELBOWS (D x W) | | | |
| | 95 DEGREE | | | |
| | 24 | ACG | 5710441 | 3.0 lbs |
| | 24 | PVDF | 58104__ | 3.0 lbs |
| | 45 DEGREE | | | |
| | 24 | ACG | 5710841 | 3.0 lbs |
| | 24 | PVDF | 58108__ | 3.0 lbs |

TYPE A ELBOWS

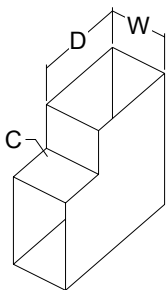

TYPE B ELBOWS

Notes:

Type "A" & "B" has seam on heel. Specify otherwise at time of order.

| OFFSET CLEAT | GAUGE | FINISH | PRODUCT NO. | WT | LENGTH |
|--------------|-------|----------------------------|-------------|---------|--------|
| | 24 | Supplied in Various Colors | 5806499 | 2.4 lbs | 10'-2" |

| CLEAT | GAUGE | FINISH | PRODUCT NO. | WT | LENGTH |
|-------|-------|----------------------------|-------------|---------|--------|
| | 24 | Supplied in Various Colors | 5806099 | 2.4 lbs | 10'-2" |

| 2 3/8" T-ARMOR Z-CLOSURE | GAUGE | FINISH | PRODUCT NO. | WT | LENGTH |
|--------------------------|-------|--------|-------------|---------|--------|
| | 24 | ACG | 5854541 | 3.5 lbs | 10'-2" |
| | 24 | PVDF | 58545__ | 3.5 lbs | 10'-2" |





| 3" T-ARMOR Z-CLOSURE | GAUGE | FINISH | PRODUCT NO. | WT | LENGTH |
|----------------------|-------|--------|-------------|---------|--------|
| | 24 | ACG | 5854641 | 4.0 lbs | 10'-2" |
| | 24 | PVDF | 58546__ | 4.0 lbs | 10'-2" |

| 2 3/8" T-ARMOR RIB COVER | GAUGE | FINISH | PRODUCT NO. | WT | LENGTH |
|--|-------|--------|-------------|---------|--------|
| | 24 | PVDF | 58547__ | 0.1 lbs | 8" |
| | 24 | ACG | 5854741 | 0.1 lbs | 8" |
| | 22 | PVDF | 60547__ | 0.2 lbs | 8" |
| | 22 | ACG | 6054741 | 0.2 lbs | 8" |
| For use on panel with a eave to wall transition (knee cap). Two Rib Covers are required per panel. | | | | | |

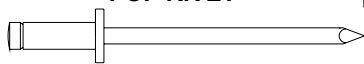
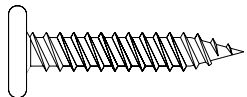
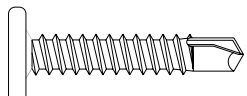

| 3" T-ARMOR RIB COVER | GAUGE | FINISH | PRODUCT NO. | WT | LENGTH |
|--|-------|--------|-------------|---------|--------|
| | 24 | PVDF | 58549__ | 0.2 lbs | 8" |
| | 24 | ACG | 5854941 | 0.2 lbs | 8" |
| | 22 | PVDF | 60549__ | 0.2 lbs | 8" |
| | 22 | ACG | 6054941 | 0.2 lbs | 8" |
| For use on panel with a eave to wall transition (knee cap). Two Rib Covers are required per panel. | | | | | |

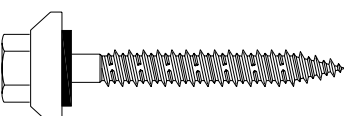
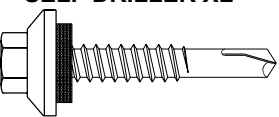
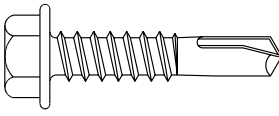
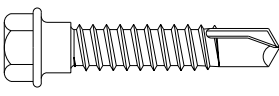
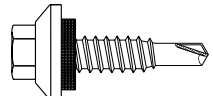
| ROOF CLEAT | GAUGE | FINISH | PRODUCT NO. | WT | LENGTH |
|------------|-------|----------------------------|-------------|----------|--------|
| | 24 | Supplied in Various Colors | 5806499 | 2.40 lbs | 10'-2" |

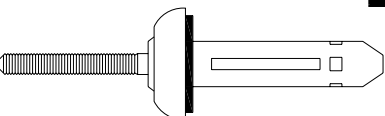

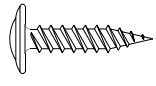
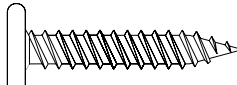

* See chart on page 6.

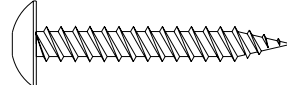
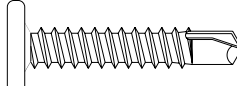
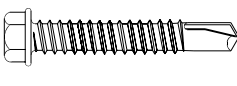
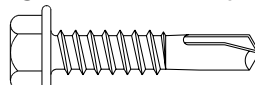
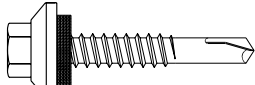
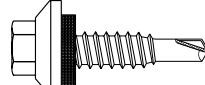
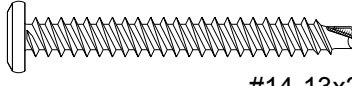
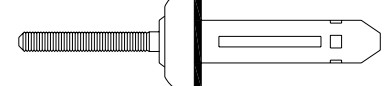
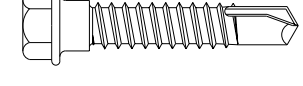
| | | | | | | |
|--|----------------|--------------------|----------------------|----------------------|---------------|---|
|  <p>POP RIVET</p> | SIZE | TYPE | QTY | PRODUCT NO. | FINISH | APPLICATION |
| | 1/8"X 3/16" | A | 250 | 8240901 | Unpainted | Flashing to Panel or Flashing |
| | 1/8"X 3/16" | A | 250 | 82409__ | Painted | Flashing to Panel or Flashing |
|  <p>PANCAKE HEAD WOOD SCREW</p> | SIZE | TYPE | QTY | PRODUCT NO. | FINISH | APPLICATION |
| | #10-12x1" | A | 250 | 8243100 | Plated | Flashing to wood decking |
|  <p>PANCAKE HEAD DRILLER</p> | SIZE | TYPE | QTY | PRODUCT NO. | FINISH | APPLICATION |
| | #10-16x1" | Driller | 250 | 8242100 | Plated | Flashing to metal substructure |
|  <p>LOW PROFILE WOOD SCREW</p> | SIZE | TYPE | QTY | PRODUCT NO. | FINISH | APPLICATION |
| | #12-11x1 1/2" | A | 250 | 8244100 | Plated | Clips to wood decking |
|  <p>WOOD SCREW XL</p> | SIZE | TYPE | QTY | PRODUCT NO. | FINISH | APPLICATION |
| | #10-14x1 1/2" | A | 250 | 8212300 | Unpainted | Panel or Flashing to wood substructure |
| | #10-14x1 1/2" | A | 250 | 82123__ | Painted | |
|  <p>SELF DRILLER XL</p> | SIZE | TYPE | QTY | PRODUCT NO. | FINISH | APPLICATION |
| | #12-14x1 1/4" | Driller | 250 | 8235300 | Unpainted | Panel or Flashing to metal substructure |
| | #12-14x1 1/4" | Driller | 250 | 82353__ | Painted | |
|  <p>SELF DRILLER NO WASHER</p> | SIZE | TYPE | QTY | PRODUCT NO. | FINISH | APPLICATION |
| | 1/4"-14x1 1/2" | Driller (#2 point) | 250 | 8249300 | Plated | Panel clips to metal substructure |
| | #12-24x1 1/4" | Driller (#4 point) | 250 | 8282000 | Plated | Panel clips to bar joists up to 3/8" thick |
| | #12-14x1" | Driller | 250 | 8242000 | Plated | Accessories to metal substructure and used with framing on retrofit |
|  <p>SHOULDER SELF DRILLER</p> | SIZE | TYPE | QTY | PRODUCT NO. | FINISH | APPLICATION |
| | 1/4"-14x1 1/4" | Driller | 250 | 8281300 | Plated | For use with Floating Rake Zee to substructure |
|  <p>STITCH SCREW XL</p> | SIZE | TYPE | QTY | PRODUCT NO. | FINISH | APPLICATION |
| | 1/4"-14x7/8" | Stitch | 250 | 8236800 | Unpainted | Flashing to Panel or Flashing |
| | 1/4"-14x7/8" | Stitch | 250 | 82368__ | Painted | |
|  <p>DECK SCREW</p> | SIZE | TYPE | QTY | PRODUCT NO. | FINISH | APPLICATION |
| | #14-13x2"-8" | Driller | Contact Sales Branch | Contact Sales Branch | Black | Panel Clip to metal deck and rigid board insulation assembly or wood substructure |
|  <p>BULB-TITE RIVET (Aluminum)</p> | SIZE | TYPE | QTY | PRODUCT NO. | FINISH | APPLICATION |
| | 9/32"x1-3/8" | A | Contact Sales Branch | 8240400 | Unpainted | Fasten panels at endlaps and attach Z-Closure at Ridge, Hip and Peak |
| | 9/32"x1-3/8" | A | Contact Sales Branch | 82404__ | Painted | |

PHYSICAL PROPERTIES

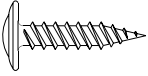
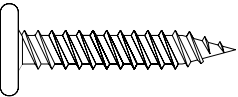
| FASTENER | HEAD DIA/TYPE | THREAD DIA. O.D. | THREAD DIA. I.D. | MIN TENSILE | MIN. TORSIONAL | NOM. SHEAR |
|--|----------------------------------|------------------|------------------|-------------|----------------|------------|
|  <p>TRUSS HEAD WOOD SCREW #8-15x³/₄"</p> | Truss Hd. #2 Philips | .162-.168 | .105-.110 | 1672 lbs | 61 In lbs | 1087 lbs |
|  <p>PANCAKE HEAD WOOD SCREW #10-12x1"</p> | .447 IN. #2 Philips Square | .188-.194 | .126-.133 | 1673 lbs | 79 In lbs | 1311 lbs |
|  <p>WOOD SCREW XL #10-14x1", 1¹/₂"</p> | 1/4" HWH | .175-.181 | .127-.133 | 2429 lbs | 80 In lbs | 1355 lbs |
|  <p>LOW PROFILE WOOD SCREW #12-11 x 1¹/₂"</p> | #3 Square Drive | .201-.208 | .125-.131 | 2050 lbs | 81 In lbs | 1369 lbs |
|  <p>PANCAKE HEAD DRILLER #10-16x1"</p> | #2 Philips | .183-.189 | .135-.141 | 1984 lbs | 80 In lbs | 1442 lbs |
|  <p>SELF DRILLER NO WASHER 1/4"-14x1¹/₂"</p> | 5/16" HWH | .240-.246 | .185-.192 | | | |
|  <p>SELF DRILLER NO WASHER #12-14x1", 1¹/₂"</p> | 5/16" HWH | .209-.215 | .157-.165 | | | |
|  <p>SELF DRILLER XL #12-14x1", 1¹/₄", 1¹/₂"</p> | 5/16" HWH | .209-.215 | .157-.165 | | | |
|  <p>STITCH XL 1/4"-14x⁷/₈"</p> | 5/16" HWH | .240-.246 | .185-.192 | | | |
|  <p>DECK SCREW #14-13x2", 4", 5", 6", 8"</p> | #3 Philips .448 Max | .235-.242 | .155 | | | |
|  <p>BULB-TITE RIVET</p> | 9/32" Flange Head | | | 1100 lbs | | 1500 lbs |
|  <p>SHOULDER SELF DRILLER 1/4"-14x1¹/₄"</p> | 5/16" HWH | .263-.266 | .199-.201 | | | |

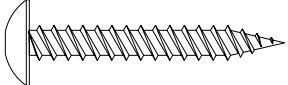
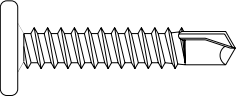
PULL OUT VALUES - POUNDS (RECOMMENDED SAFETY FACTOR)

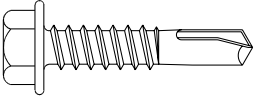
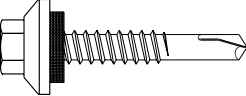
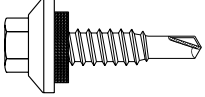
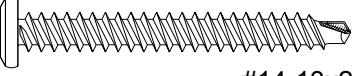
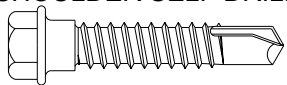
| FASTENER | Plywood | | | OSB | | Hard/Soft Wood | | | | |
|---|---------|------|-------|--------|----------------|----------------|----------------|---------------|---------------|---------------|
| | 3/4" | 5/8" | 1/2" | 19/32" | 7/16" | Spruce | Fir | Oak | Pine | |
|  TRUSS HEAD WOOD SCREW #8-15x ³ / ₄ " | 461 | 340 | 377 | | 98 | 375 | 405 | 593 | 464 | |
|  PANCAKE HEAD WOOD SCREW #10-12x1" | 615 | 521 | 339 | 290 | 257 | | | | | |
|  WOOD SCREW XL #10-14x1", 1 ¹ / ₂ " | 565 | 498 | 326 | | 223 | 1537 | | | | |
|  LOW PROFILE WOOD SCREW #12-11 x1 ¹ / ₂ " | | | | | | | | | | |
| FASTENER | Steel | | | | | | | | | |
| | 3/8" | 1/4" | 3/16" | 10 GA | 12 GA (55) | 14 GA (55) | 16 GA (55) | 18 GA (50) | 22 GA (50) | |
|  PANCAKE HEAD DRILLER #10-16x1" | | | | | 1514 (2.59) | 953 (2.54) | 825 (2.54) | | | 167 (2.69) |
|  SELF DRILLER NO WASHER 1/4"-14x1 ¹ / ₂ " | | | | | 2031 (2.55) | 1172 (2.54) | 1043 (2.55) | 951 (2.62) | | 209 (2.68) |
|  SELF DRILLER NO WASHER #12-14x1", 1 ¹ / ₂ " | | | | | 1788 (2.54) | 1056 (2.54) | 850 (3.10) | 790 (2.60) | | 180 (2.76) |
|  SELF DRILLER XL #12-14x1", 1 ¹ / ₄ ", 1 ¹ / ₂ " | | | | | | | | | | |
|  STITCH XL 1/4"-14x7/8" | | | | | | | | | | |
|  DECK SCREW #14-13x2", 4", 5", 6", 8" | | | | | | | | | | |
|  SHOULDER SELF DRILLER 1/4"-14x1 ¹ / ₄ " | | | | | | | | | | |

PULL OVER STRENGTH VALUES (POUNDS ULTIMATE)

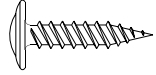
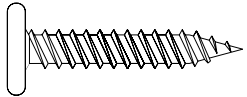
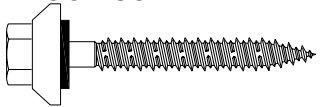
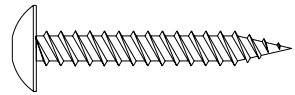
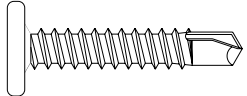
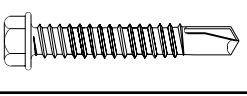
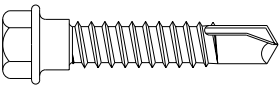
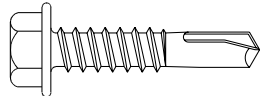
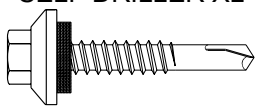
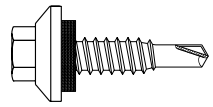
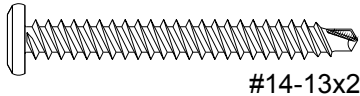
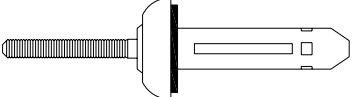
| FASTENER | STEEL | | | | | |
|---|---------------|----------------|----------------|---------------|---------------|---------------|
| | 20 GA | 22 GA (50) | 24 GA (50) | 26 GA (80) | 26 GA (50) | 29 GA (80) |
|  TRUSS HEAD WOOD SCREW #8-15x ³ / ₄ " | | N/A | 852 (2.57) | 693 (2.64) | 619 (2.60) | 546 (2.83) |
|  PANCAKE HEAD WOOD SCREW #10-12x1" | | 1129 (2.56) | 843 (2.55) | 658 (2.60) | 661 (2.55) | 500 (3.08) |
|  WOOD SCREW XL #10-14x1", 1 ¹ / ₂ " | | 901 (2.59) | 728 (2.73) | 563 (2.63) | 492 (2.67) | 426 (2.77) |
|  LOW PROFILE WOOD SCREW #12-11 x1 ¹ / ₂ " | | | | | | |
|  PANCAKE HEAD DRILLER #10-16x1" | | | 1263 (2.55) | 870 (2.63) | 654 (2.71) | |
|  SELF DRILLER NO WASHER 1/4"-14x1 ¹ / ₂ " | | | | | | |
|  SHOULDER SELF DRILLER 1/4"-14x1 ¹ / ₄ " | | | | | | |
|  SELF DRILLER NO WASHER #12-14x1", 1 ¹ / ₂ " | 751 (2.74) | | 1357 (2.61) | 918 (2.60) | 667 (2.63) | 524 (2.95) |
|  SELF DRILLER XL #12-14x1", 1 ¹ / ₄ ", 1 ¹ / ₂ " | | | | | | |
|  STITCH XL 1/4"-14x ⁷ / ₈ " | | | | | | |
|  DECK SCREW #14-13x2", 4", 5", 6", 8" | | | | | | |
|  BULB-TITE RIVET 9/32"x2 ¹ / ₂ " | | | | | | |

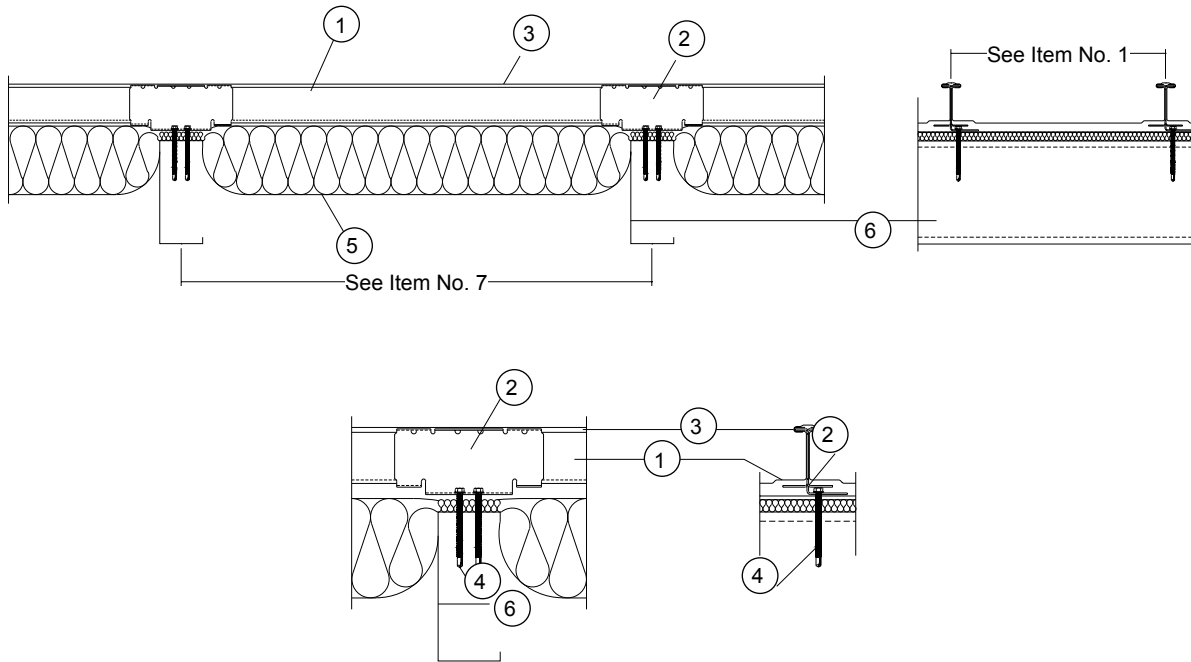

T-ARMOR

Construction No. 268
 July 15, 2013
 Uplift - Class 90
 Fire Not Investigated

1. **Metal Roof Deck Panels*** - No. 24 MSG min thick coated steel or stainless steel or min .030 thick aluminum; nom 18 in. wide, 2-3/8 in. high standing seams. Panels continuous over two or more spans. Floating end laps to occur over purlins with panels overlapped 8 in. End lap to begin 3 in. from purlin web and to extend across purlin flange. A bead of mastic sealant may be used at panel end and side laps.
2. **Panel Clips*** - No. 16 MSG min gauge coated steel or stainless steel, 6 in. long by 2.718 in. high. Base to have four .281 in. dia. guide holes to accommodate screw fasteners (Item 4)
3. **Cap** - Used at seam, nom 1 in. wide, 1/2 in. deep fabricated from min No. 24 MSG gauge steel, stainless steel, or .030 in. thick aluminum. Cap continuously seamed over panel seams using an electric seaming tool. Seaming process to include panel clips (Item 2).
4. **Fasteners** - (Screws) - Fasteners used to attach panel clips to purlin to be No. 14 by 3 in. long self tapping, hex-head, plated or stainless steel screws without washers or 1/4 in - 14 hex head drill bit without washer. Two fasteners per clip to be used. Fasteners used to attach thermal spacer (Item 6) to purlins to be same type, spaced 18 in. OC. Fastener used at end lap to be an expanding bolt type with an aluminum sleeve having a 5/8 in. diam cap with a 1/4 - 20 by 1-7/16 in. long stainless steel bolt. Spacing at end lap to be 1, 3, 3, 4, 3, 3, 1, in. pattern.
5. **Insulation** - (Optional) - Any compressible blanket insulation, 6 in. max thick before compression, or foamed plastic (rigid insulation) supplied in min thickness 1 in., max thickness 4 in.
6. **Purlins** - No. 16 MSG min steel (50,000 psi min yield strength).

| | |
|----------------|--|
| Spacing | 60 in. OC for steel panels - Class 90 |
| | 48 in. OC for aluminum panels - Class 90 |

7. **Lateral Bracing** - (Not Shown) - As required.

***Bearing the UL Classification Mark**



Underwriters Laboratories Inc.®
 LISTED

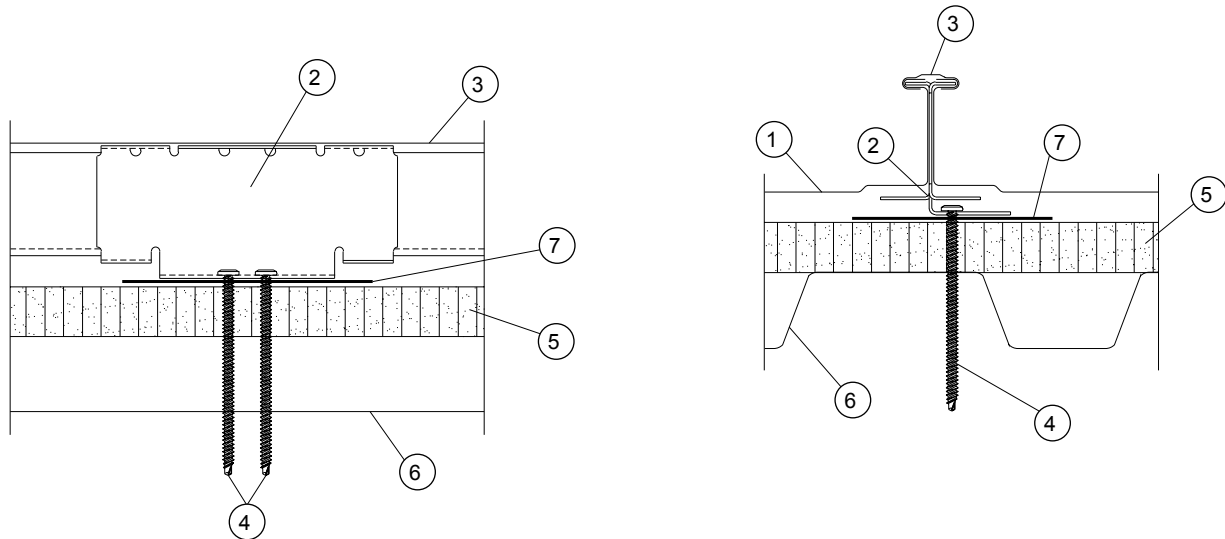

T-ARMOR

Construction No. 268A

July 15, 2013

Uplift - Class 90

Fire Not Investigated

1. **Metal Roof Deck Panels*** - No. 24 MSG steel or stainless steel or 0.030 in. thick aluminum, nom 18 in. wide, 2-3/8 in. high standing seams. Heavier gauges or narrower panels acceptable. Panels continuous over two or more spans. Floating end laps to occur over purlins with panels overlapped 8 in. End lap to begin 3 in. from purlin web and to extend across purlin flange. A bead of mastic sealant may be used at panel end and side laps.
2. **Panel Clips*** - No. 16 MSG min gauge coated steel or stainless steel, 6 in. long by 2.718 in. high. Base to have four .281 in. dia. guide holes to accommodate screw fasteners (Item 4). Clips spaced 48" on center maximum, fastened through metal decking.
3. **Cap** - Used at seam, nom 1 in. wide, 1/2 in. deep fabricated from min No. 24 MSG steel, stainless steel or 0.030 in. thick aluminum. Cap continuously seamed over panel seams with a special motorized seaming tool. Seaming process to include panel clips (Item 2)
4. **Fasteners - (Screws)** - Fasteners used to attach panel clips (Item 2) to liner panel to be No. 12 self-tapping, hex-head, plated or stainless steel screw without washers or #14-13 with No. 3 phillips head Deck Screw. Two fasteners per clip to be used. Fasteners used to attach thermal spacer (Item 9) to purlins to be same type spaced 18 in. OC. Fasteners used at end lap to be expanding bolt type with an aluminum sleeve having a 5/8 in. diam cap with a 1/4-20 by 1-7/16 in. long stainless steel bolt. Spacing at end lap to be 1, 3, 3, 4, 3, 3 in. pattern. Length to depend on thickness of insulation and/or thermal spacers and to be 3/4 in. longer than overall depth of deck assembly.
5. **Foamed Plastic** - (Optional) - Extruded foamed plastic (rigid Insulation) min density 2.00 pcf supplied in min thickness 1 in., max thickness 4 in.
6. **Liner Panel** - Fabricated from No. 22 MSG min thickness coated steel. Min depth 15/16 in., max pitch 7.2 in., min yield strength 33 ksi. or 18/20 MSG thickness (No 22 MSG min) coated steel, 4-1/2 in. deep, (24 in. coverage), min yield strength 33 ksi. Max span of panel units to be per manufacturer's instructions. Panels attached to structural supports with screws or welds per liner panel manufacturer's instructions.
7. **Bearing Plate** - (Optional) - No. 22 MSG steel, 6 in. by 6 in. Used with rigid insulation only.
8. **Supports (Purlins)** - (Not Shown) - Purlins used for liner panels to be cold formed steel sections. As alternates, structural steel components (hot rolled beams, channels, open web joist etc.) may be used. Min gauge and yield to depend on design considerations. Max spacing to depend on design considerations.
9. **Thermal Spacer** - (Optional) - (Not Shown) - Located over liner panel at panel clip locations. Continuous nom wood 2 in. by 4 in. Not used when foamed plastic (Item 5) is used.

Refer to General Information, Roof Deck Construction (Roofing Materials and Systems Directory) for items not evaluated.

10. **Plywood or OSB** - (Optional) (Not Shown) - Min APA rated plywood, nom 1/2 in. thick or oriented strand board (OSB), nom 7/16 in. thick, 4 x 8 ft. Sheets to be installed on top of Foamed Plastic (Item 5) in lieu of bearing plates (Item 7)

*Bearing the UL Classification Mark



Underwriters Laboratories Inc. ®
LISTED

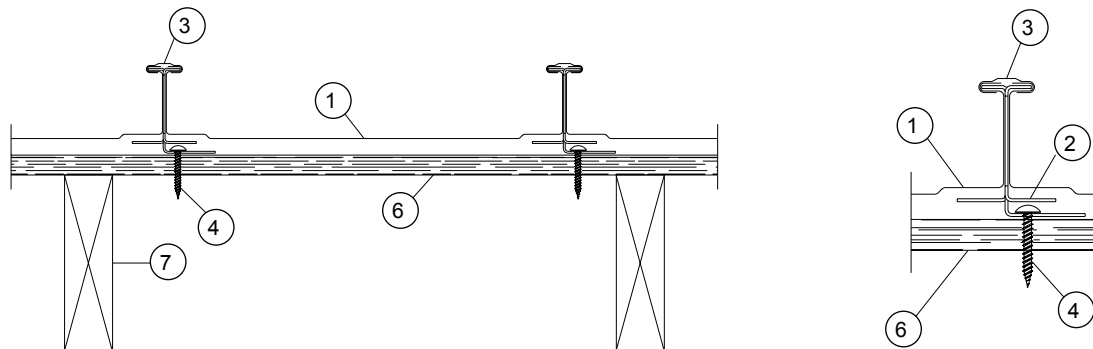

T-ARMOR

Construction No. 268B

July 15, 2013

Uplift - Class 90

Fire Not Investigated

1. **Metal Roof Deck Panels*** - Min No. 24 MSG gauge steel or stainless steel or 0.030 in. thick aluminum, nom 18 in. wide, 2-3/8 in. high standing seams. Heavier gauges or narrower panels acceptable. Panels continuous over three or more clips with no end laps.
2. **Panel Clips*** - No. 16 MSG min gauge coated steel or stainless steel, 6 in. long by 2.718 in. high. Base to have four .281 in. dia. guide holes to accommodate screw fasteners (Item 4). Clips spaced 24" on center maximum, fastened through plywood decking.
3. **Cap** - Used at seam, nom 1 in. wide, 1/2 in. deep fabricated from min No. 24 MSG gauge steel, stainless steel, or .030 in. thick aluminum. Cap continuously seamed over panel seams using an electric seaming tool. Seaming process to include panel clips (Item 2).
4. **Fasteners - (Screws)** - Fasteners used to attach panel clips to plywood deck to be No. 12-11 Low profile, No.3 Square drive wood screw. Two fasteners per clip to be used.
5. **Underlayment** - (Optional) - (Not Shown) Underlayment used over plywood deck to be type 15 or 30 organic felt. Sides overlapped min 2 in., end laps per manufacturer's instructions. Felt nailed to plywood deck with 1-1/4 in. long steel cap nails, located per manufacturer's instructions. Nail spacing to be max 12 in. OC at the side lap and max 24 in. OC in interior rows. **As An Alternate** - A self-adhering modified bitumen water proofing membrane may be used, installed per manufacturer's instructions. Note - when alternate is used the plywood joints need not be sealed.
6. **Plywood Decking** - Plywood decking to be graded per PS83 specifications, 19/32 in. thick, exposure 1, APA Rated Sheathing (42/20) square edged. Butt ends not blocked. All butt and side joints to be sealed against leakage by using tape and/or caulk. (Note exception under Item 5, Alternate).
7. **Supports** - Spaced max of 24 in OC. Any of the following types may be used to support the plywood decking.
 - a) Nom 2 by 6 in., No. 2 grade or better S-P-F, Hemlock Fir, Douglas Fir or Southern Yellow Pine or equivalent.
 - b) Wood trusses with a nom 2 by 4 in. upper chord of the grade as item a.
 - c) No. 22 MSG min cold formed coated steel (min yield to be 33 ksi)
8. **Plywood Fasteners** - (Not Shown) - Fasteners used to attach the plywood deck to the supports to be as follows:
 - a) For plywood-to-wood supports No. 8-18 by 1-7/8 in. long bugle-head steel screw with a No. 2 Phillips drive, a "Hi-Low" thread pattern and an "S-Point".
 - b) As an alternate to Item a, 8d common nails may be used.
 - c) For plywood-to-steel supports for a steel thickness less than No. 20 MSG No. 7-19 by 1-1/4 in. long bugle-head steel screw with a No. 2 Phillips drive, a "Hi-Low" thread pattern and an "S-Point". For a steel thickness greater than No. 20 MSG to No. 16 MSG, No. 6-20 by 1-1/4 in. long bugle-head steel screws with a No. 2 phillips drive and a S12 (TekS/3)supR point.

Spacing: Fasteners spacing for all fasteners types to be 6 in OC at the plywood edges and 12 in. OC in the interior.

Refer to General Information, Roof Deck Construction (Roofing Materials and Systems Directory) for items not evaluated.

*Bearing the UL Classification Mark



Underwriters Laboratories Inc. ®
LISTED

T-ARMOR

UL 263 FIRE RESISTANCE RATINGS

Metal Roof Deck Panels

Metal Sales Manufacturing Corporation has obtained fire resistance ratings for various products conducted according to test criteria set forth by 'Underwriters Laboratories' "Standard Fire Tests of Building Construction and Material" (ANSI/UL 263). This test procedure is identical to ASTM E-119 and NFPA 251.

The fire resistance rating is for the total assembly and not just the external metal panel. Ratings are expressed in hours and vary depending upon the assemblies.

In general, the test criteria is to evaluate the assembly's ability to continue to support the superimposed loads and resist the passage of flame, high temperatures, or hot gases which will ignite combustible materials. The test assemblies are identified by an alpha-numeric design number.

For detail information on specific assemblies and hourly ratings see UL Fire Resistance Directory.



Underwriters Laboratories Inc. ®
LISTED

T-ARMOR

TESTING SUMMARY

| Category | Test Protocol | Description |
|-------------------|-----------------|---|
| Fire | UL 790 | Class A roof covering over noncombustible deck or framing ot with fire barrier over combustible materials |
| | ASTM E 84 | Flame Spread |
| Structural | UL 580 | Class 90 uplift roofs over steel purlins, 5/8" plywood or 22 ga steel deck |
| | ASTM E 1592 | Uplift load resistance for a range of thicknesses, widths and heights |
| | ASTM E 1592 | Gravity load resistance |
| | ASTM E 330 | Load resistance |
| Water Penetration | TAS 100 | Wind Driven Rain, specimen subject to 110 mph wind with 8.8 inches/hour water spray with no leaks |
| | AAMA 501.1 | Water penetration under dynamic prssure |
| | ASTM E 1646 | Water penetration of exterior metal roof panel system |
| | ASTM E 331 | Water penetration of exterior curtain wall |
| Air Leakage | ASTM E 1680 | Air leakage through exterior metal roof panel system |
| | ASTM E 283 | Air leakage through exterior curtian wall |
| Thermal Movement | Cyclic Movement | Clips and seam progressed through 100,000 two inch movement cycles |
| Impact | ICC 500 | Large missile impact |
| | FEMA 361 | Large missle impact |
| | ASTM E 1996 | Large missle impact with cyclic wind pressure testing |
| | ASTM E 1886 | Large missle impact with cyclic wind pressure testing |
| | TAS 201, 203 | Large missle impact with cyclic wind pressure testing |

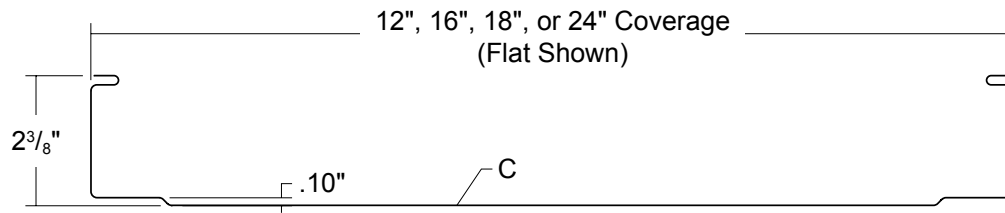

STEEL SECTION PROPERTIES

ALLOWABLE UNIFORM LOADS psf (3 or More Equal Spans)

| Thick ga | Width in | Yield ksi | Weight psf | Top In Compression | | Bottom In Compression | | Inward Load | | | | | | Outward Load | | | | | |
|-------------|-------------|--------------|---------------|----------------------------|----------------------------|----------------------------|----------------------------|----------------|-----|-----|-----|-----|----|-----------------|-----|-----|-----|-----|----|
| | | | | Ixx in ⁴ /ft | Sxx in ³ /ft | Ixx in ⁴ /ft | Sxx in ³ /ft | 3' | 4' | 5' | 6' | 7' | 8' | 3' | 4' | 5' | 6' | 7' | 8' |
| | | | | | | | | | | | | | | | | | | | |
| 24 | 12 | 50 | 1.50 | 0.3398 | 0.2053 | 0.2078 | 0.1758 | 362 | 222 | 149 | 107 | 80 | 62 | 500 | 300 | 192 | 133 | 98 | 75 |
| 22 | 12 | 50 | 1.97 | 0.4640 | 0.2806 | 0.3020 | 0.2466 | 500 | 326 | 216 | 153 | 114 | 88 | 500 | 362 | 241 | 172 | 128 | 99 |
| 20 | 12 | 33 | 2.42 | 0.5750 | 0.3458 | 0.4100 | 0.3107 | 453 | 272 | 180 | 127 | 95 | 73 | 489 | 296 | 197 | 140 | 104 | 81 |
| 24 | 16 | 50 | 1.35 | 0.2828 | 0.1601 | 0.1260 | 0.0944 | 215 | 127 | 84 | 59 | 44 | 34 | 328 | 184 | 118 | 82 | 60 | 46 |
| 22 | 16 | 50 | 1.78 | 0.3810 | 0.2157 | 0.1800 | 0.1397 | 328 | 192 | 126 | 88 | 65 | 50 | 453 | 273 | 175 | 121 | 89 | 68 |
| 20 | 16 | 33 | 2.18 | 0.4733 | 0.2657 | 0.2460 | 0.2012 | 304 | 180 | 118 | 83 | 62 | 48 | 372 | 227 | 151 | 107 | 80 | 62 |
| 24 | 18 | 50 | 1.30 | 0.2567 | 0.1419 | 0.1113 | 0.0836 | 190 | 113 | 74 | 52 | 39 | 30 | 290 | 163 | 105 | 73 | 53 | 41 |
| 22 | 18 | 50 | 1.71 | 0.3507 | 0.1932 | 0.1600 | 0.1242 | 292 | 171 | 112 | 78 | 58 | 45 | 404 | 243 | 155 | 108 | 79 | 61 |
| 20 | 18 | 33 | 2.10 | 0.4340 | 0.2383 | 0.2180 | 0.1785 | 270 | 160 | 105 | 74 | 55 | 42 | 333 | 203 | 135 | 96 | 72 | 55 |
| 24 | 24 | 50 | 1.21 | 0.2035 | 0.1060 | 0.0835 | 0.0627 | 143 | 85 | 56 | 39 | 29 | 22 | 218 | 122 | 78 | 54 | 40 | 31 |
| 22 | 24 | 50 | 1.58 | 0.2815 | 0.1475 | 0.1200 | 0.0929 | 218 | 128 | 84 | 59 | 43 | 33 | 307 | 181 | 116 | 81 | 59 | 45 |
| 20 | 24 | 33 | 1.94 | 0.3495 | 0.1818 | 0.1640 | 0.1342 | 203 | 120 | 79 | 56 | 41 | 32 | 253 | 154 | 103 | 73 | 55 | 42 |

1. Section properties and allowable loads are calculated per AISI 2007.
2. Ixx and Sxx are effective section properties for deflection and bending.
3. Allowable loads are calculated considering bending, shear, combined bending and shear and deflection.
4. Allowable load calculations do not include consideration for web crippling, fastener / connection limitations or uplift testing.
5. Allowable loads do not include a 1/3 stress increase.

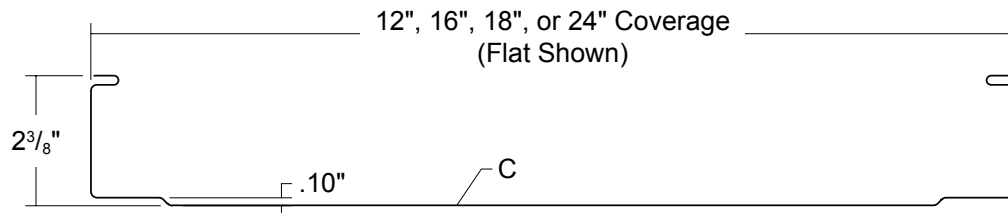

ALUMINUM SECTION PROPERTIES

ALLOWABLE UNIFORM LOADS psf (3 or More Equal Spans)

| Thick in | Width in | Yield ksi | Weight psf | I in ⁴ /ft | S _{TOP} in ³ /ft | S _{BOT} in ³ /ft | | | | | | | | | | | | |
|-------------|-------------|--------------|---------------|--------------------------|---|---|-----|----|----|----|----|----|-----|-----|-----|----|----|----|
| | | | | | | | 3' | 4' | 5' | 6' | 7' | 8' | 3' | 4' | 5' | 6' | 7' | 8' |
| 0.032 | 12 | 17 | 0.73 | 0.5110 | 0.3093 | 0.7391 | 65 | 37 | 24 | 17 | 12 | 9 | 217 | 134 | 90 | 65 | 48 | 37 |
| 0.040 | 12 | 17 | 0.91 | 0.6350 | 0.3857 | 0.9163 | 101 | 58 | 37 | 26 | 19 | 15 | 286 | 177 | 119 | 85 | 64 | 50 |
| 0.032 | 16 | 17 | 0.65 | 0.4200 | 0.2378 | 0.7261 | 48 | 27 | 18 | 12 | 9 | 7 | 163 | 101 | 68 | 49 | 36 | 28 |
| 0.040 | 16 | 17 | 0.82 | 0.5228 | 0.2960 | 0.9012 | 74 | 42 | 27 | 19 | 14 | 11 | 218 | 135 | 91 | 65 | 49 | 38 |
| 0.032 | 18 | 17 | 0.63 | 0.3867 | 0.2129 | 0.7222 | 42 | 24 | 15 | 11 | 8 | 6 | 145 | 90 | 60 | 43 | 32 | 25 |
| 0.040 | 18 | 17 | 0.79 | 0.4793 | 0.2655 | 0.8939 | 66 | 37 | 24 | 17 | 12 | 9 | 194 | 121 | 82 | 58 | 44 | 34 |
| 0.032 | 24 | 17 | 0.58 | 0.3100 | 0.1626 | 0.7102 | 31 | 18 | 11 | 8 | 6 | 5 | 109 | 67 | 45 | 32 | 24 | 19 |
| 0.040 | 24 | 17 | 0.73 | 0.3865 | 0.2025 | 0.8796 | 48 | 28 | 18 | 12 | 9 | 7 | 147 | 91 | 62 | 44 | 33 | 26 |

1. Section properties and allowable loads are calculated per Aluminum Design Manual, 2010 Edition.
2. Allowable loads are calculated considering bending, shear, combined bending and shear and deflection.
3. Allowable load calculations do not include consideration for web crippling, fastener / connection limitations or uplift testing.
4. Allowable loads do not include a 1/3 stress increase in uplift.

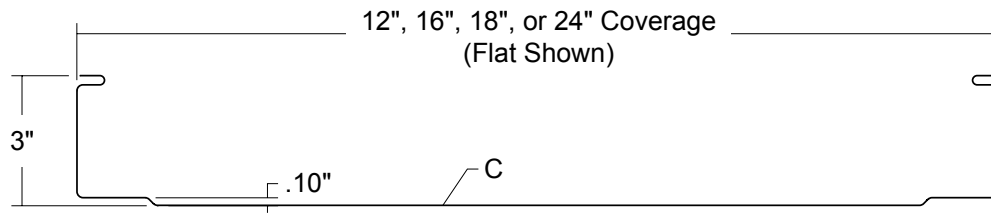

STEEL SECTION PROPERTIES

ALLOWABLE UNIFORM LOADS psf (3 or More Equal Spans)

| Thick ga | Width in | Yield ksi | Weight psf | Top In Compression | | Bottom In Compression | | Inward Load | | | | | | Outward Load | | | | | |
|-------------|-------------|--------------|---------------|----------------------------|----------------------------|----------------------------|----------------------------|----------------|-----|-----|-----|-----|-----|-----------------|-----|-----|-----|-----|-----|
| | | | | Ixx in ⁴ /ft | Sxx in ³ /ft | Ixx in ⁴ /ft | Sxx in ³ /ft | 3' | 4' | 5' | 6' | 7' | 8' | 3' | 4' | 5' | 6' | 7' | 8' |
| | | | | | | | | | | | | | | | | | | | |
| 24 | 12 | 50 | 1.60 | 0.5756 | 0.2723 | 0.3676 | 0.2442 | 379 | 251 | 178 | 132 | 101 | 80 | 473 | 355 | 254 | 177 | 130 | 99 |
| 22 | 12 | 50 | 2.10 | 0.7900 | 0.3776 | 0.5290 | 0.3434 | 500 | 419 | 284 | 204 | 153 | 119 | 500 | 447 | 305 | 221 | 166 | 130 |
| 20 | 12 | 33 | 2.57 | 0.9970 | 0.4828 | 0.7140 | 0.4332 | 500 | 377 | 250 | 177 | 132 | 102 | 500 | 411 | 274 | 195 | 145 | 112 |
| 24 | 16 | 50 | 1.43 | 0.4665 | 0.2063 | 0.2235 | 0.1328 | 247 | 157 | 107 | 77 | 58 | 46 | 355 | 259 | 166 | 115 | 85 | 65 |
| 22 | 16 | 50 | 1.87 | 0.6428 | 0.2869 | 0.3195 | 0.1964 | 424 | 256 | 170 | 121 | 90 | 70 | 500 | 338 | 231 | 167 | 125 | 96 |
| 20 | 16 | 33 | 2.29 | 0.8213 | 0.3716 | 0.4320 | 0.2786 | 419 | 249 | 163 | 115 | 85 | 66 | 500 | 314 | 210 | 150 | 112 | 86 |
| 24 | 18 | 50 | 1.37 | 0.4260 | 0.1839 | 0.1987 | 0.1177 | 219 | 139 | 95 | 69 | 52 | 40 | 315 | 230 | 147 | 102 | 75 | 57 |
| 22 | 18 | 50 | 1.80 | 0.5887 | 0.2560 | 0.2840 | 0.1743 | 376 | 228 | 151 | 107 | 80 | 62 | 475 | 301 | 206 | 149 | 111 | 85 |
| 20 | 18 | 33 | 2.20 | 0.7547 | 0.3333 | 0.3833 | 0.2475 | 372 | 221 | 145 | 102 | 76 | 58 | 461 | 281 | 188 | 134 | 100 | 77 |
| 24 | 24 | 50 | 1.25 | 0.3390 | 0.1388 | 0.1485 | 0.0880 | 164 | 104 | 71 | 51 | 39 | 30 | 236 | 172 | 110 | 76 | 56 | 43 |
| 22 | 24 | 50 | 1.65 | 0.4695 | 0.1935 | 0.2125 | 0.1306 | 282 | 171 | 113 | 80 | 60 | 46 | 357 | 227 | 156 | 113 | 83 | 64 |
| 20 | 24 | 33 | 2.02 | 0.6080 | 0.2539 | 0.2880 | 0.1857 | 279 | 166 | 109 | 77 | 57 | 44 | 349 | 214 | 143 | 102 | 76 | 59 |

1. Section properties and allowable loads are calculated per AISI 2007.
2. Ixx and Sxx are effective section properties for deflection and bending.
3. Allowable loads are calculated considering bending, shear, combined bending and shear and deflection.
4. Allowable load calculations do not include consideration for web crippling, fastener / connection limitations or uplift testing.
5. Allowable loads do not include a 1/3 stress increase.

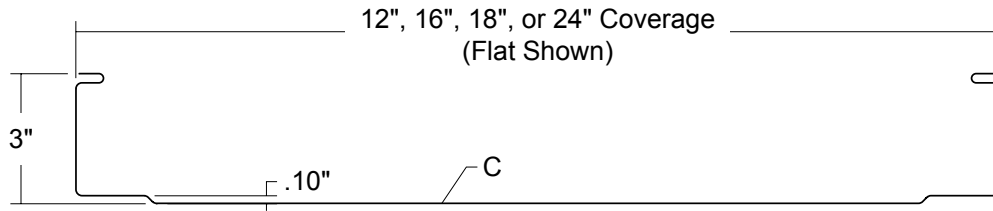

ALUMINUM SECTION PROPERTIES

ALLOWABLE UNIFORM LOADS psf (3 or More Equal Spans)

| Thick in | Width in | Yield ksi | Weight psf | I in ⁴ /ft | S _{TOP} in ³ /ft | S _{BOT} in ³ /ft | | | | | | | | | | | | |
|-------------|-------------|--------------|---------------|--------------------------|---|---|-----|----|----|----|----|----|-----|-----|-----|-----|----|----|
| | | | | | | | 3' | 4' | 5' | 6' | 7' | 8' | 3' | 4' | 5' | 6' | 7' | 8' |
| 0.032 | 12 | 17 | 0.77 | 0.8880 | 0.4313 | 0.9734 | 85 | 49 | 31 | 22 | 16 | 12 | 254 | 158 | 106 | 76 | 57 | 44 |
| 0.040 | 12 | 17 | 0.96 | 1.1060 | 0.5374 | 1.2099 | 133 | 76 | 49 | 34 | 25 | 19 | 361 | 224 | 151 | 108 | 81 | 63 |
| 0.032 | 16 | 17 | 0.69 | 0.7313 | 0.3319 | 0.9503 | 62 | 35 | 23 | 16 | 12 | 9 | 190 | 117 | 79 | 57 | 42 | 33 |
| 0.040 | 16 | 17 | 0.86 | 0.9105 | 0.4135 | 1.1803 | 97 | 55 | 35 | 25 | 18 | 14 | 271 | 168 | 113 | 81 | 61 | 47 |
| 0.032 | 18 | 17 | 0.66 | 0.6727 | 0.2977 | 0.9420 | 55 | 31 | 20 | 14 | 10 | 8 | 168 | 104 | 70 | 50 | 38 | 29 |
| 0.040 | 18 | 17 | 0.83 | 0.8367 | 0.3709 | 1.1695 | 85 | 48 | 31 | 22 | 16 | 12 | 241 | 150 | 101 | 72 | 54 | 42 |
| 0.032 | 24 | 17 | 0.61 | 0.5425 | 0.2275 | 0.9240 | 40 | 23 | 15 | 10 | 8 | 6 | 126 | 78 | 52 | 37 | 28 | 22 |
| 0.040 | 24 | 17 | 0.76 | 0.6750 | 0.2833 | 1.1462 | 62 | 36 | 23 | 16 | 12 | 9 | 181 | 112 | 76 | 54 | 41 | 32 |

1. Section properties and allowable loads are calculated per Aluminum Design Manual, 2010 Edition.
2. Allowable loads are calculated considering bending, shear, combined bending and shear and deflection.
3. Allowable load calculations do not include consideration for web crippling, fastener / connection limitations or uplift testing.
4. Allowable loads do not include a 1/3 stress increase in uplift.

RECEIVING MATERIAL

It is the responsibility of the installer to unload material from the delivery truck. The installer shall be responsible for providing suitable equipment for unloading of material from the truck.

After receiving material, check the condition of the material, and review the shipment against the shipping list to ensure all materials are accounted for. If damages or shortages are discovered, it should be noted on the Bill of Lading at the time of delivery. A claim should be made against the carrier as soon as possible. Metal Sales is not responsible for any damages or shortages unless they are documented in writing and presented to Metal Sales within 48 hours.

GENERAL HANDLING

Each bundle should be handled carefully to avoid being damaged. Care should be taken to prevent bending of the panel or abrasion to finish. Whenever possible, the bundle should remain crated until it is located in its place of storage. If bundles must be opened, we recommend recrating them before lifting. To avoid damage, please lift the bundle at its center of gravity.

CAUTION

Improper loading and unloading of bundles and crates may result in bodily harm and/or material damage. Metal Sales is not responsible for bodily injuries and/or material damages resulting from improper loading and unloading.

MECHANICAL HANDLING

Forklift - A forklift may be used for panels up to 20'-0" long. Please make sure the forks are at their maximum separation. Do not transport open bundles. When transporting bundles across rough terrain, or over a longer distance, some means of supporting the panel load must be used.

Crane - A crane should be used when lifting panels with lengths greater than 20'-0". Please be sure to utilize a spreader bar to ensure the even distribution of the weight to the pick up points. As a rule when lifting panels, no more than $\frac{1}{3}$ of the length of the panel should be left unsupported. Never use wire rope because this will damage the panels.

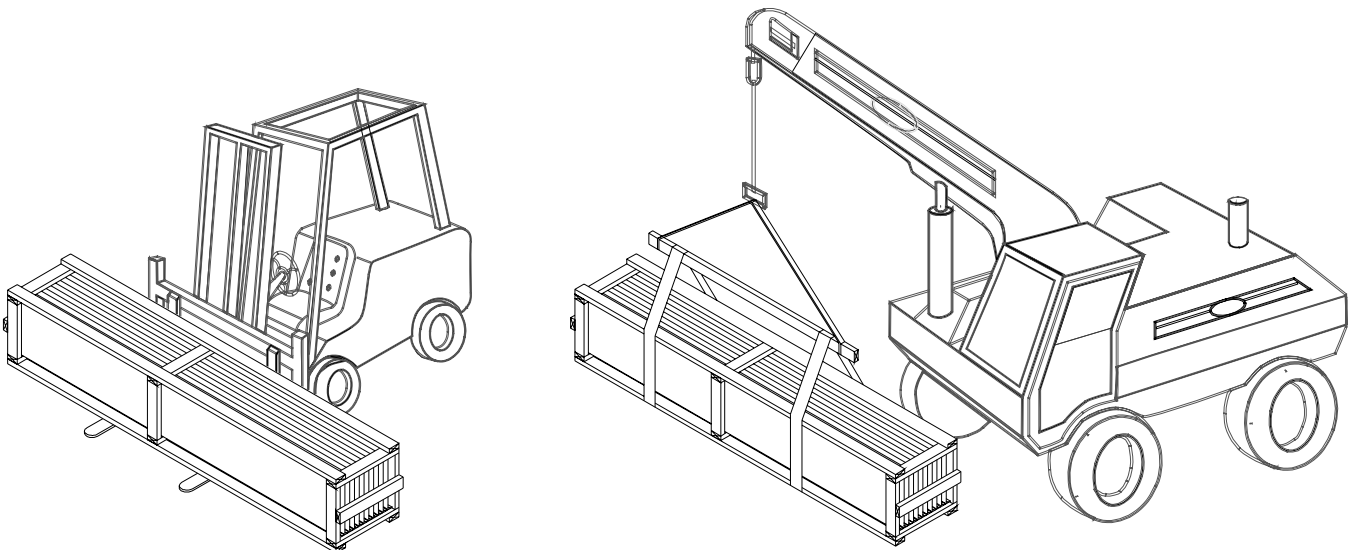

MANUAL HANDLING

When handling painted steel care should be taken to prevent scratching of material. Clean gloves should be worn at all times to prevent a reaction with salts found on bare skin. Installers should wear rubber sole shoes to keep from scuffing material while walking on the roof.

Handling of individual panels should be done carefully and properly to avoid bending or damaging. T-Armor panels should be carried by grasping the edge of the panel so that the T-Armor panel is vertical to the ground. The T-Armor panel should not be carried with the panel horizontal to the ground as this could cause the panel to buckle or bend in the center.

Normally individual panels can be handled by people placed every 6'-0" to 8'-0" along the length of the panel.

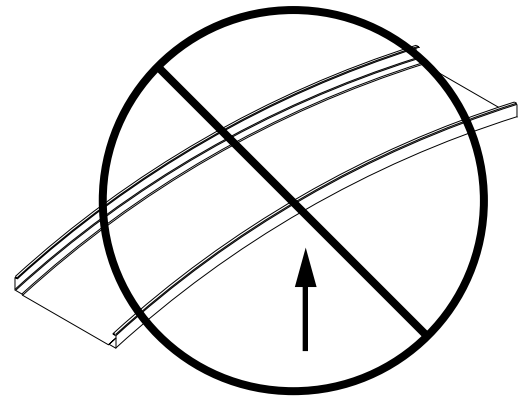
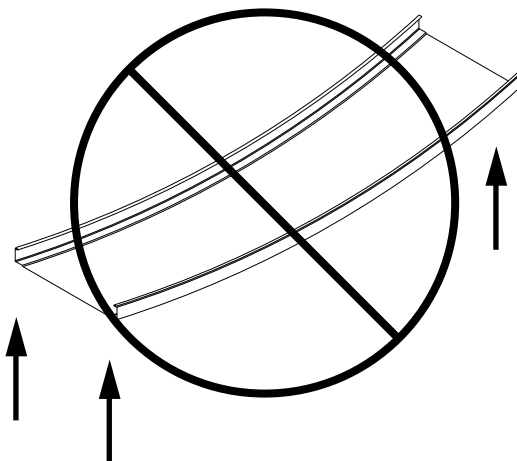
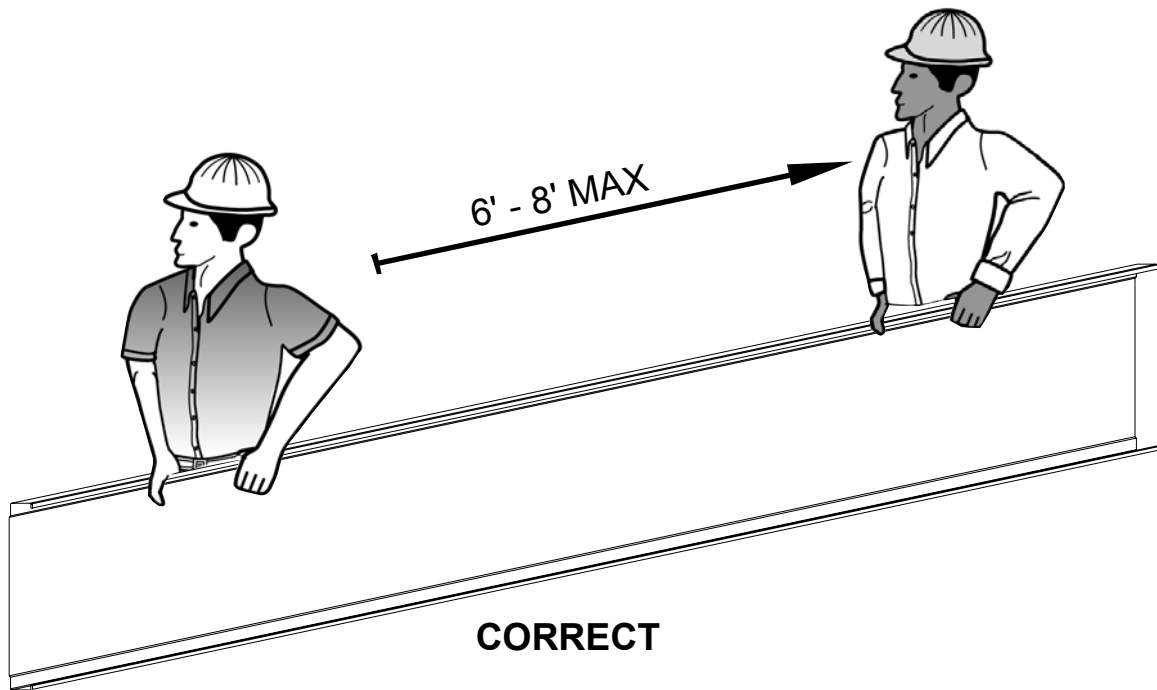

INCORRECT

GENERAL

Please inspect panels for moisture accumulation. If moisture has formed, the panels should be unbundled, wiped dry, and allowed to dry completely. Once dry, carefully restack the panels and loosely recover allowing for ample air circulation.

Bundled sheets should be stored high enough off of the ground to allow for air circulation and prevent contact with accumulating water. If possible, elevate one end of the bundle to allow any moisture to run off the panels. Metal Sales recommends covering the bundle with a tarp. Do not use tight fitting plastic-type tarp as panel bundle covers. While they may provide protection from heavy downpours, they can also retard necessary ventilation and trap heat and moisture that may accelerate metal corrosion. If panels are to be stored in possible bad weather, we suggest they be stored inside. Extended storage of panels in a bundle is not recommended. **Under no circumstances should the sheets be stored near or come in contact with salt water, corrosive chemicals, ash, or fumes generated or released inside the building or nearby plants, foundries, plating works, kilns, fertilizer, and wet, green treated lumber.**

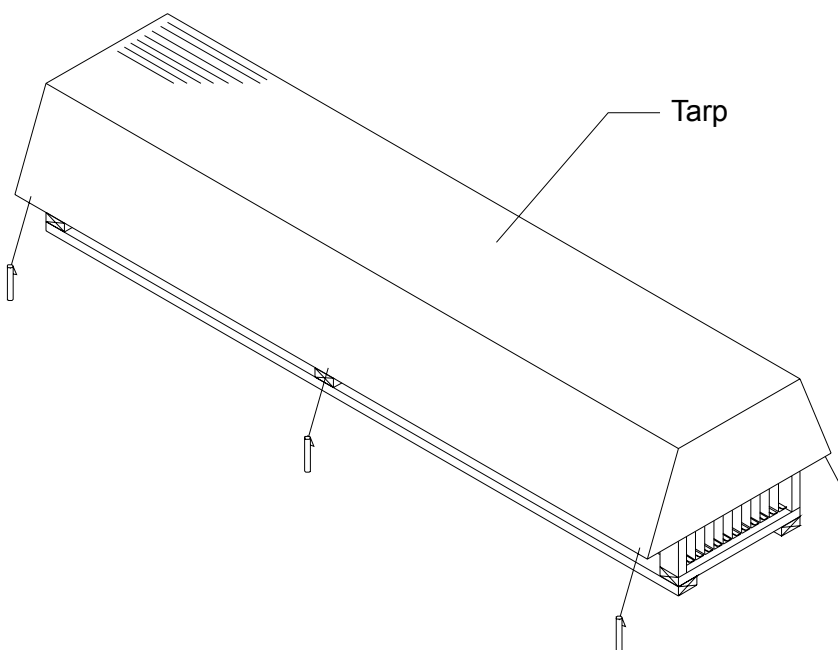
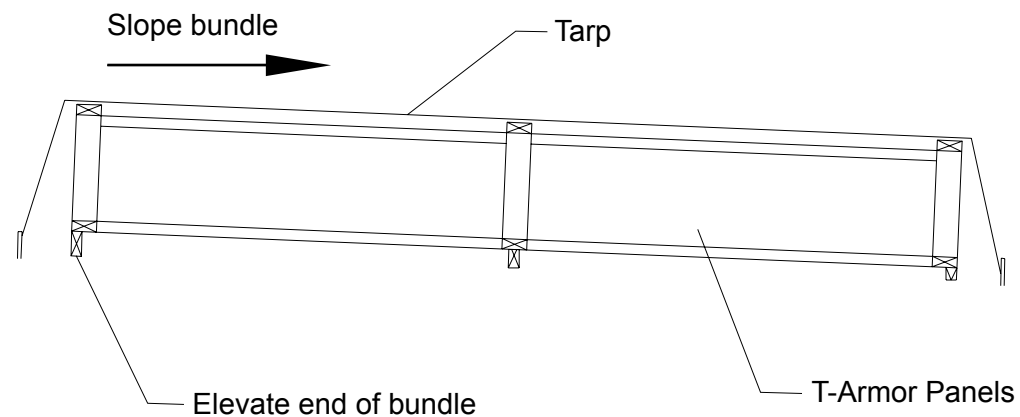

STORAGE ON ROOF

To facilitate the handling of T-Armor panels, panel bundles can be lifted and placed on the roof. Bundles need to be placed on the roof in order for the roof structure to handle the weight. Loading capabilities of the structure must be checked.

When lifting packaged sheets, make certain they are adequately supported. Panels less than 20'-0" in length can normally be lifted with a forklift; however, when lifting panels in excess of 20'-0", it is recommended that a spreader bar and slings be used. As a rule, when lifting, no more than $\frac{1}{3}$ of the length of the panel can be left unsupported.

Make a plan for bundle placement by determining how much area a bundle of panels will cover. Bundles should be placed on the roof in accordance with the direction the panel will be installed. Consider where the string line, if any, is to run at the eave to set roof panels by. Roof bundles should not interfere with this string line.

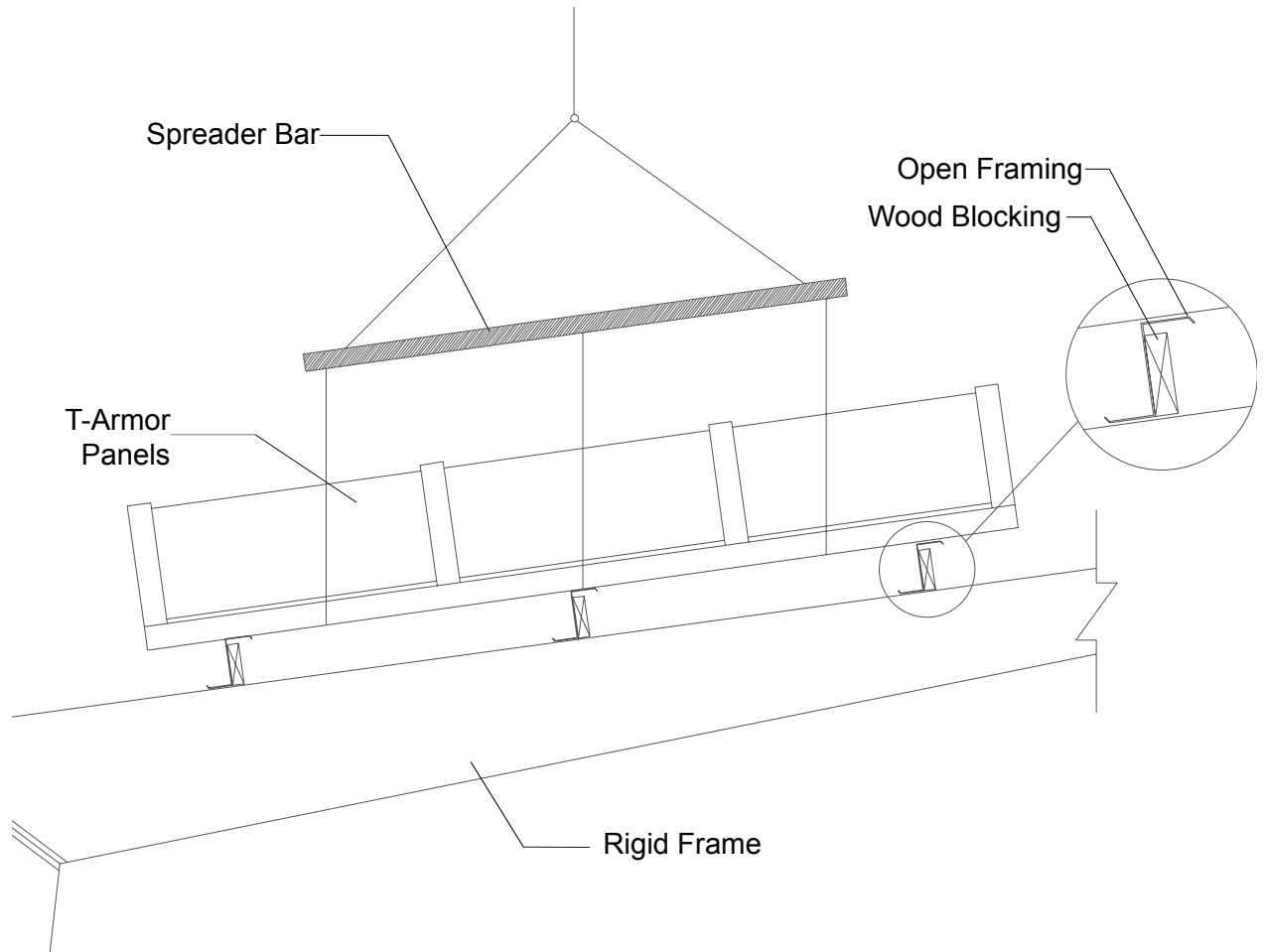
**INSTALL CONCERNS**

- Remove stripable film before significant exposure to sunlight.
- Do not mark on Acrylic Coated Galvalume (ACG) with a penil - use felt marker.
- Do not leave ms-HT underlayment exposed for extended period.
- Do not install copper or lead on the roof.
- Remove burrs from exposed fasteners.
- Keep panels and trims clean.
- Do not cut metal on the roof with a curcular saw.
- Do not install panels directly over metal supports, include insulation to reduce noise.

Care of metal panels and flashings must be exercised throughout erection. Foot traffic can cause distortion of panel and damage to finish. Traffic over the installed system must be kept to an absolute minimum. If continuous foot traffic is necessary for maintenance over certain areas of the roof, then a permanent walkway should be installed.

When walking on the roof panels is unavoidable, walk only in the flats of the panel. Walking on the ribs can cause damage to the panels. If T-Armor is installed over open framing, step in the flat of the panel only and as close to the framing as possible.

OVER OPEN FRAMING

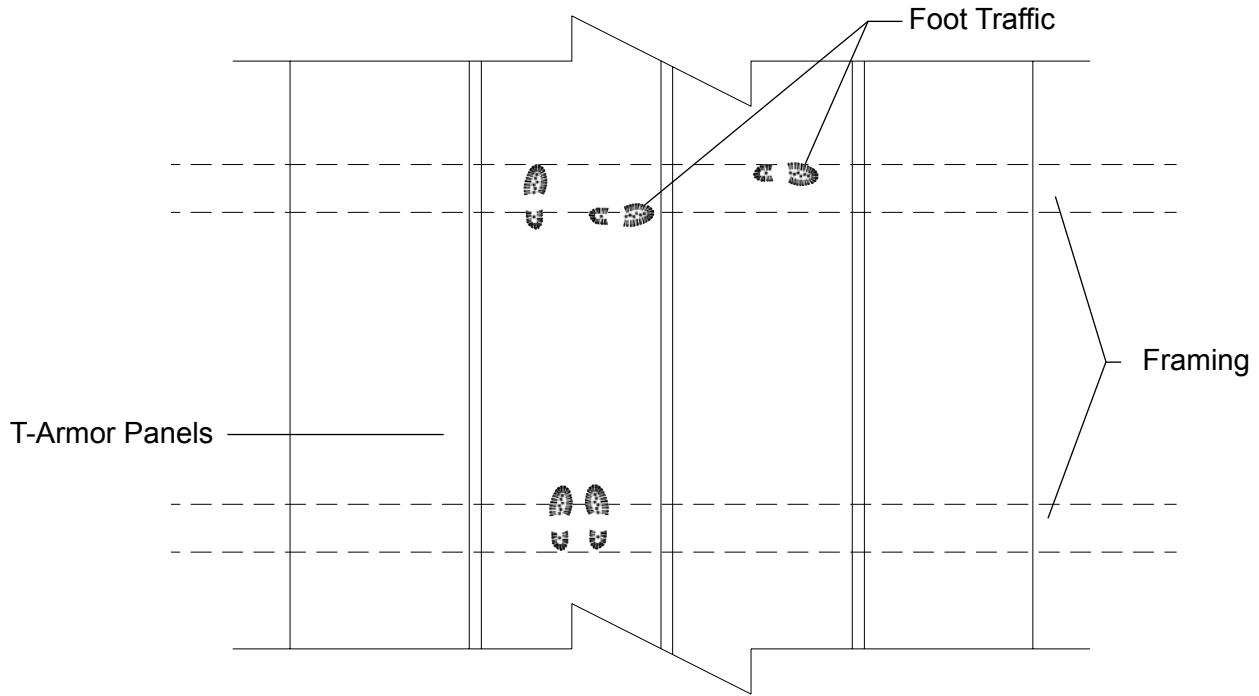

CURB INSTALLATION

Size and location of all roof penetrations should be an important consideration. Areas around roof vents or rooftop units may show that corrosive fumes are emitted from a process within the building.

Curbs can be obtained from any of the following manufacturers:

| | | | |
|-------------------------|---------------|-------------|---------------|
| KCC International, Inc. | (800)382-2872 | Custom Curb | (800)251-3001 |
| ThyCurb | (800)666-2872 | LM Curbs | (800)284-1412 |
| Curbs Plus, Inc. | (888)639-2872 | FastCurbs | (877)728-3278 |

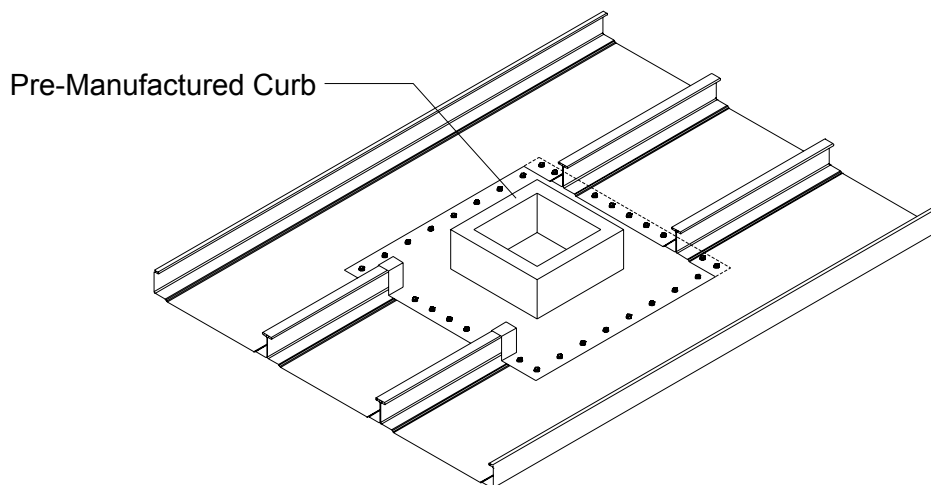

FIELD-CUTTING

Tin snips or a "nibbler" type electric tool are recommended for field cutting T-Armor panels. Cutting the metal generates slivers or metal chips. These slivers and metal chips must be immediately removed from the T-Armor panels because they will damage the finish and shorten the life of the product.

One method of preventing this problem is to turn the T-Armor panels over before cutting. This allows the slivers and metal chips to be brushed from the back side and avoids damaging the paint on the top side of the panels.

When cutting T-Armor panels, goggles must be worn for eye protection.

CAUTION

All product surfaces should be free of debris at all times. Installed surfaces should be wiped clean at the end of each work period. Never cut panels over metal surfaces. Metal shavings will rust on the surface, voiding the warranty.

TOUCH-UP PAINT

All painted panels and flashings have a factory-applied baked-on finish. Handling and installing panels may result in some small scratches or nicks to the paint finish. Touch-up paint is available in matching colors from Metal Sales. It is recommended that a small brush be used to apply touch-up paint to those areas that are in need of repair. Touch-up paint does not have the superior chalk and fade resistance of the factory applied paint finish and will normally discolor at an accelerated rate. Aerosol paint should not be used because of the overspray that may occur.



SPRAY PAINT

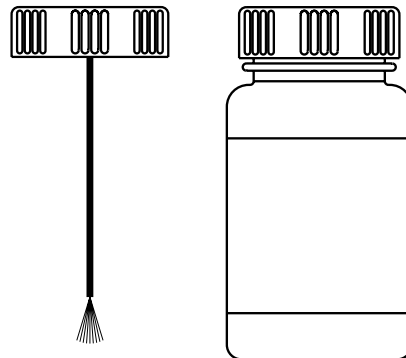

TOUCH-UP PAINT

FASTENER INSTALLATION TECHNIQUE

Recommended Tool Type - Use depth locating nose or adjustable clutch on screw gun to prevent overdrilling and strip out. **Do not use impact tools or runners.**

Seating the washer - Apply sufficient torque to seat the washer - do not overdrive the fastener.

| | CORRECT Sealing material slightly visible at edge of metal washer. Assembly is watertight. | TOO LOOSE Sealing material is not visible; not enough compression to seal properly. | TOO TIGHT Metal washer deformed; sealing material pressed beyond washer edge. |
|---------------------|--|---|---|
| SELF DRILLER | | | |
| WOODSCREW | | | |

To prevent wobbling - Make sure fastener head is completely engaged in the socket. If the head does not go all the way in the socket - tap the magnet deeper into the socket to allow full head engagement. Metal chips will build up from drilling and should be removed from time to time.

Protect drill point - Push only hard enough on the screw gun to engage clutch. This prevents excess friction and burn out of the drill point. Correct pressure will allow screw to drill and tap without binding.

Drilling through sheet and insulation - Ease up on pressure when drilling through insulation to avoid striking the purlin or girt with the point - apply more pressure after drill point contacts purlin or girt.

Drilling through purlin overlaps - Drilling through lapped purlins requires extra care. Excessive voids between purlins sometimes damages drill points and two self-drillers might be necessary to complete the operation. It is sometimes advantageous to predrill.

CONDITION OF SUBSTRUCTURE

Whether over solid substrate or open structural framing, panel distortion may occur if not applied over properly aligned and uniform substructure.

The installer should check the roof deck for squareness before installing T-Armor panels. Several methods can be used to verify squareness of the structure for proper installation of the panels.

METHOD "A" - One method for checking the roof for squareness is to measure diagonally across one slope of the roof from similar points at the ridge and eave and obtain the same dimension.

METHOD "B" - The 3-4-5 triangle system may also be used. To use this system measure a point from the corner along the edge of the roof at a module of three (3). Measure a point from the same corner along another edge at a module of four (4). Then by measuring diagonally between the two points established, the dimension should be exactly a module of five (5) to have a square corner. Multiple uses of this system may be required to determine building squareness. If the endwall cannot be made square, the roof system cannot be installed as shown in these instructions.

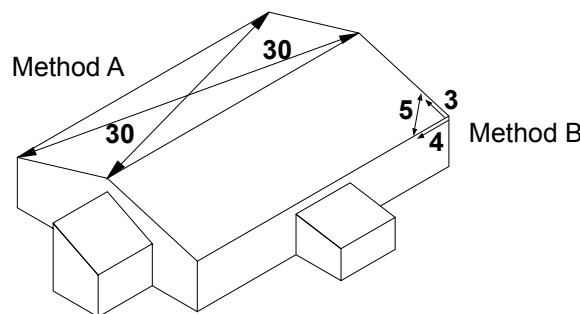

VENTILATION

Proper design and installation of vapor barriers and ventilation systems are important to prevent condensation and the resulting problems of moisture damage and loss of insulation efficiency.

Condensation occurs when moisture-laden air comes in contact with a surface temperature equal to or below the dew point of the air. This phenomenon creates problems that are not unique with metal buildings; these problems are common to all types of construction.

The underside of the metal roof on a typical metal building (no attic) should be protected from condensation by insulating with a faced insulation. This should reduce the potential of condensation forming on the underside of the panels.

On buildings that have an attic space or are being retrofitted with a metal roofing system, vents should be placed at both the eave and peak of the roof in order to prevent a buildup of moisture (humidity) in the attic space.

See ASHRAE Standard 62.2 for guidance on ventilation requirements and design.

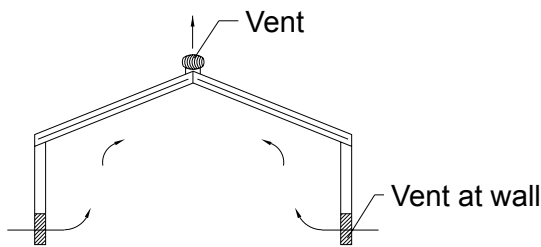

TYPICAL METAL BUILDING (NO ATTIC)

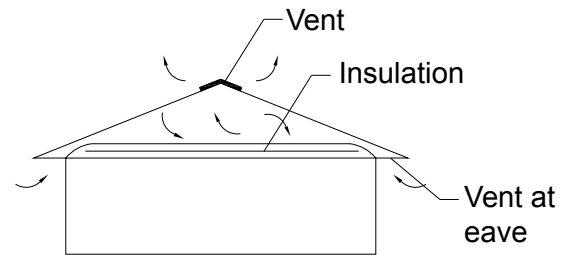

BUILDING WITH ATTIC OR RETROFITTED

INSULATION

In most cases insulation is installed directly under roof panels. Insulation is recommended on all applications to act as a sound barrier, prevent condensation and increase insulating value of a roof system.

Many different types of insulation can be used with the metal roof panels. Blanket, batt, rigid, and reflective insulation are just to name a few. Please contact your insulation supplier for specific recommendations on installation of insulation and vapor barriers.

When applying a compressible type of insulation over open framing members. Rigid thermal blocks can be used to help reduce heat lost at purlin locations.

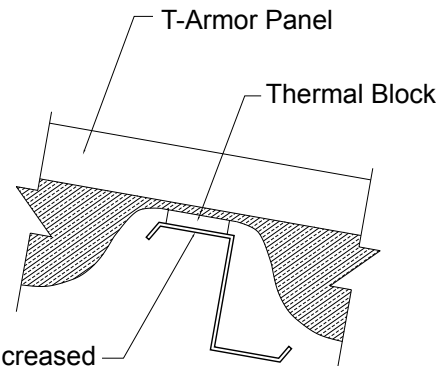
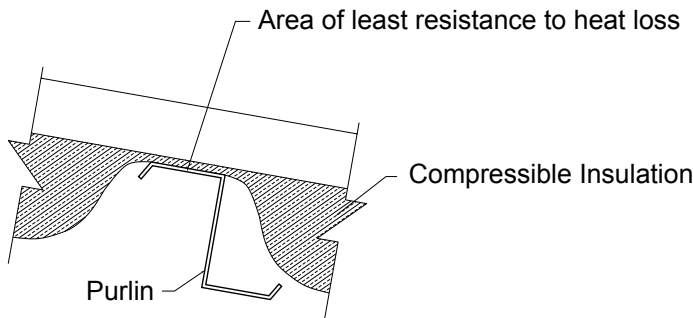

CAUTION

Use extreme care when working next to insulation. The insulation will provide a false sense of security by hiding the view of the ground below

SYSTEM EXPANSION / CONTRACTION

Metal roofing panels are subject to dimensional changes after installation due to exposure to varying temperatures. The greatest influence is solar energy. Steel roofing absorbs various amounts of heat depending upon color, finish, angle of exposure and time of exposure.

The relationship of the roof temperature to building structural temperature must be considered when designing a T-Armor roof system. The clips for the T-Armor panels are designed for expansion and contraction of the panels in the longitudinal direction. Lateral expansion and contraction is accommodated by the configuration of the panel cross section and causes negligible panel movement.

Every panel requires one fixed point to keep the panel in place. Do not install a panel with multiple fixed points. Multiple fixed points will cause the thermal movement to damage the roof system.

SELECTION OF SYSTEM COMPONENTS

The T-Armor roof system can be installed with components that allow the panels to either float independently or fix permanently to the substructure. Choice of system will depend upon building design and regional temperature range (from summer highs to winter lows).

| SYSTEM COMPONENTS | | | | | |
|---|---------------------------------|--------------------------------------|---------------------------------|---------------|--------------------|
| SYSTEM | CLIP | EAVE PLATE | RAKE ANGLE | THERMAL BLOCK | INSULATION |
| 2 ³ / ₈ " UTILITY | 2 ³ / ₈ " | 1/4" UTILITY | 2 ⁵ / ₈ " | NONE REQUIRED | 1/2" TO 4" BLANKET |
| 2 ³ / ₈ " LOW | 2 ³ / ₄ " | 3/8" LOW | 2 ⁵ / ₈ " | NONE REQUIRED | 4" TO 6" BLANKET |
| 2 ³ / ₈ " HIGH | 3 ³ / ₄ " | 1 ³ / ₈ " HIGH | 3 ³ / ₄ " | 1" | 4" TO 6" BLANKET |
| 3" UTILITY | 3" | 1/4" UTILITY | 3 ¹ / ₈ " | NONE REQUIRED | 1/2" TO 4" BLANKET |
| 3" LOW | 3 ³ / ₈ " | 3/8" LOW | 3 ¹ / ₈ " | NONE REQUIRED | 4" TO 6" BLANKET |
| 3" HIGH | 4 ³ / ₈ " | 1 ³ / ₈ " HIGH | 4 ¹ / ₈ " | 1" | 4" TO 6" BLANKET |

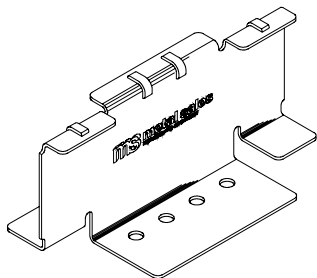

T-Armor Standard Clip

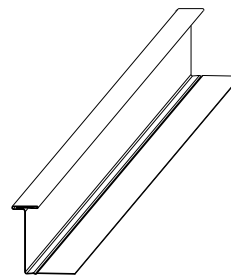

T-Armor Continuous Clip

The following chart should be used to determine proper fasteners required for clip installation on the selected applications. (See Fastener Selection Guide page 24 for other fasteners available.)

| APPLICATION | INSTALLATION REQUIREMENTS | | **CLIP SPACING | TYPE OF FASTENER | NUMBER REQUIRED |
|---|---------------------------|------------|----------------|--------------------------------------|-----------------|
| CLIPS OVER PURLINS (16 GA. MIN) | STANDARD | 24, 22 GA. | 5'-0" O.C. | 1/4"-14 x 1 1/2" SELF DRILLER N/W | 2 FASTENERS |
| | STANDARD | .032" AL | 4'-0" O.C. | 1/4"-14 x 1 1/2" SELF DRILLER N/W | 2 FASTENERS |
| CLIPS OVER 5/8" WOOD DECK | STANDARD | 24, 22 GA. | 2'-0" O.C. | #12-11x1 1/2" LOW PROFILE WOOD SCREW | 2 FASTENERS |
| | STANDARD | .032" AL | 2'-0" O.C. | #12-11x1 1/2" LOW PROFILE WOOD SCREW | 2 FASTENERS |
| CLIP OVER RIGID INSULATION / METAL DECK | STANDARD | 24, 22 GA. | 4'-0" O.C. | #14-13 DECK SCREW * | 2 FASTENERS |
| | STANDARD | .032" AL | 4'-0" O.C. | #14-13 DECK SCREW * | 2 FASTENERS |

* Length of Deck Screw will vary depending on the total thickness of the rigid insulation and metal. (See page 24.)

** Contact your local Metal Sales branch representative for more information. (See pages 2 and 3.)

Factory-Notched Panels - Metal Sales can provide factory-notched panel ends to eliminate material build up or reliance on field-notching for weathertight seams at panel endlaps.

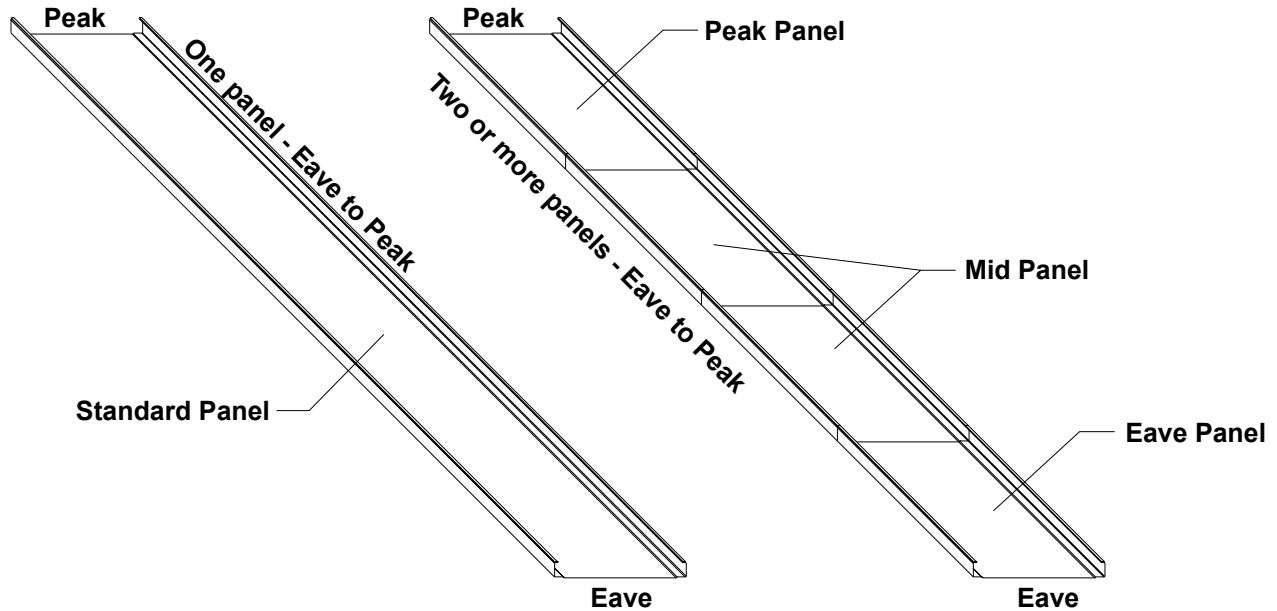

| | |
|--|--|
| <p><u>STANDARD PANEL (Not Notched):</u></p> <ul style="list-style-type: none"> ▶ Used when field-cut panels are required ▶ Used as an Peak panel for endlaps ▶ One panel from eave to peak of roof ▶ No notching ▶ 'L' is the Order Length: 80' max length, 6' min length | |
| <p><u>EAVE NOTCHED PANEL:</u></p> <ul style="list-style-type: none"> ▶ Used when endlapping of panels is not required ▶ Used when field cut panels is not required ▶ One panel from eave to peak of roof ▶ Eave notching for hemming the panel ▶ 'L' is the Order Length : 80' max length, 6' min length | |
| <p><u>ENDLAP NOTCHED PANEL:</u></p> <ul style="list-style-type: none"> ▶ Used when endlapping of panels is required but panels will not be hemmed ▶ Used as mid panel of endlapping run ▶ Notched for panel endlapping ▶ 'L' is the Order Length : 80' max length, 6' min length | |
| <p><u>EAVE & ENDLAP NOTCHED PANEL:</u></p> <ul style="list-style-type: none"> ▶ Used when endlapping of panels is required and panels will be hemmed ▶ Notched for panel endlapping ▶ Eave notching for hemming the panel ▶ 'L' is the Order Length : 80' max length, 6' min length | |
| <p><u>CAP END NOTCHING:</u></p> <ul style="list-style-type: none"> ▶ Used to be turned down at the eave ▶ Used for End Laps ▶ Used to tuck under high side flashings ▶ 'L' is the Order Length : 80' max length, 6' min length <p><small>*Note eave turn down not recommended in high snow or high debris areas</small></p> | |

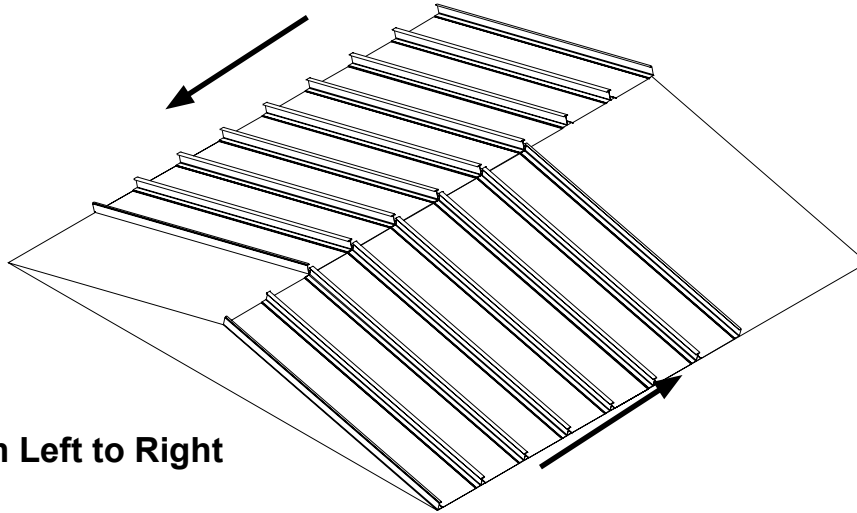

Install From Left to Right

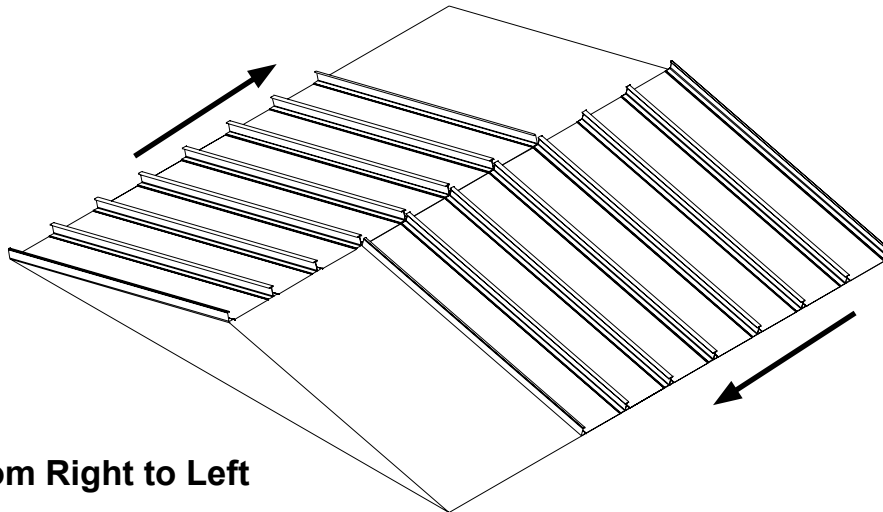

Install From Right to Left

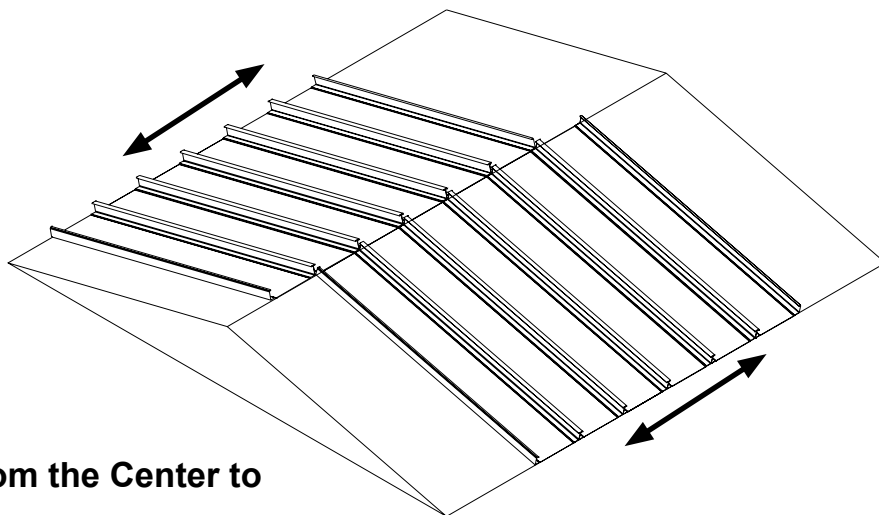

Install From the Center to the Ends

INSTALLING EAVE FLASHING

STEP
1

Steps:

1. For High clip, install the High Eave Plate first (not shown). Install Roof Cleat, fastening into roof framing with fasteners 1'-0" oc.
2. Hook Eave flashing onto the Roof Cleat and temporarily fasten into place.
3. Install continuous row of Double Bead Tape Sealant across the top of the Eave flashing.
4. Install Offset Cleat at Double Bead Tape Sealant and use #14-13 Deck Screws 1'-0" oc to fasten to the roof.

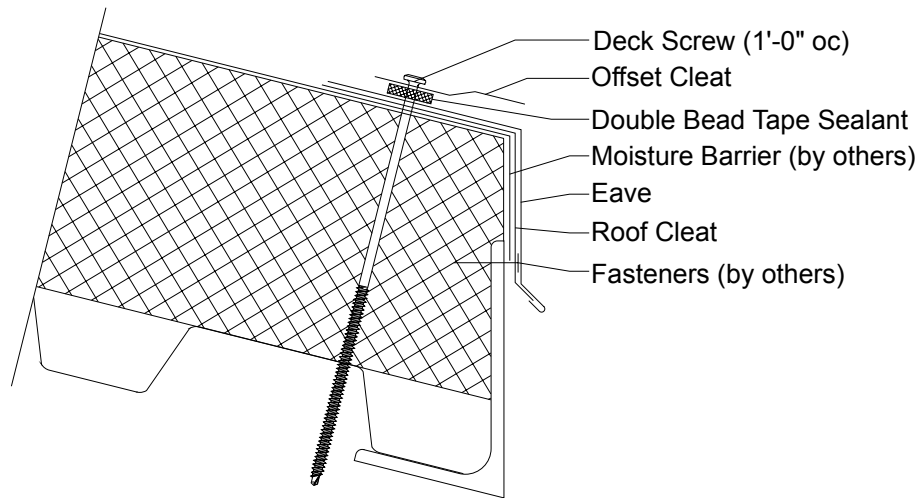

5. If two or more Eave flashings are required lap the flashing over the previously installed flashing by a minimum of 2"

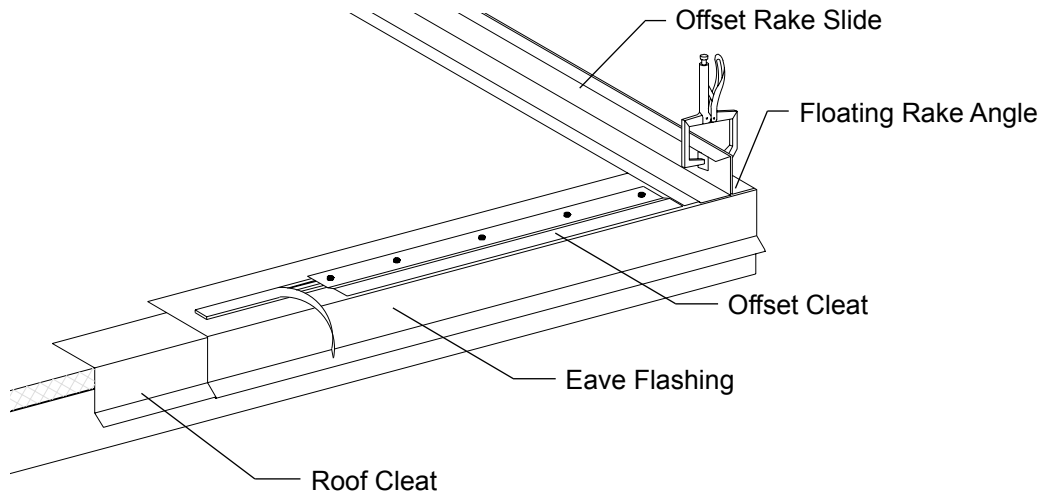

INSTALLING FLOATING RAKE ANGLE

STEP
2

Note: The Floating Rake Angle (page 14) must be attached to the framing member along the rake. Size of Floating Rake Angle can vary, (see System Components list on page 44). The following procedures are based on systems utilizing floating panel clips.

Steps:

1. At the eave of the building (looking eave to peak), align the Floating Rake Angle flush with the edge of the roof. **It is critical that the Floating Rake Angle be straight and square with the building as it controls the alignment of the roof panels.**
2. Fasten Floating Rake Angle with #14-13 Deck Screws (lengths vary per thickness of insulation) into the center of each slot, (1'-0" intervals). **Do not overtighten screws. Movement of the Floating Rake Angle is imperative for proper installation of the roof system.**
3. If two or more Floating Rake Angles are required, butt ends of Floating Rake Angles (**Do not overlap**) and continue fastening.

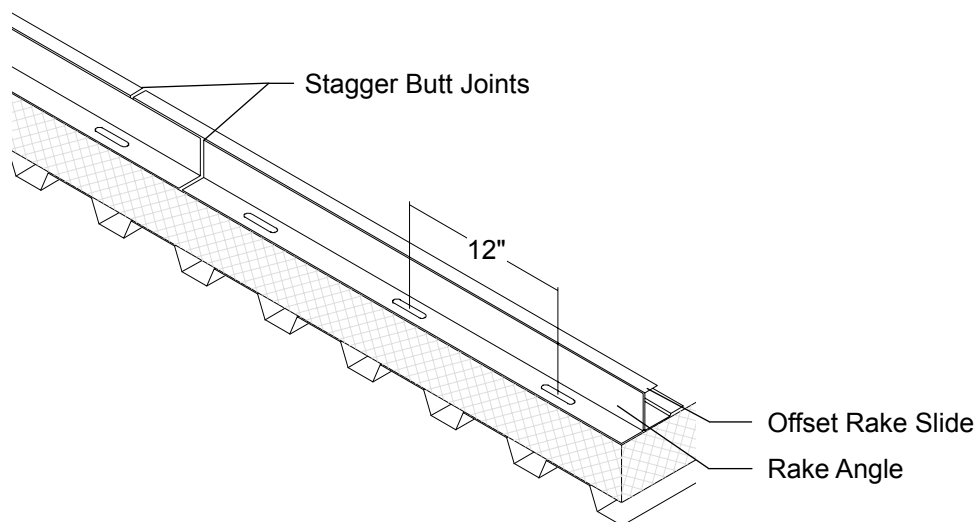

4. If necessary, field-cut Floating Rake Angle to terminate 6"-12" from peak of building.
5. Install Floating Rake Angle on the opposite end where the panels terminate using the same procedures as above.
6. Install Offset Rake Slide against the Floating Rake Angle, use a C-Clamp to temporary hold the Offset Rake Slide in place.
7. If two or more Offset Rake Slides are required, butt ends of Offset Rake Slides (**Do not overlap**) making sure to stagger the butt ends of the Floating Rake Angle.
8. Install a continuous row of Double Bead Tape Sealant to the side of the Offset Rake Slide

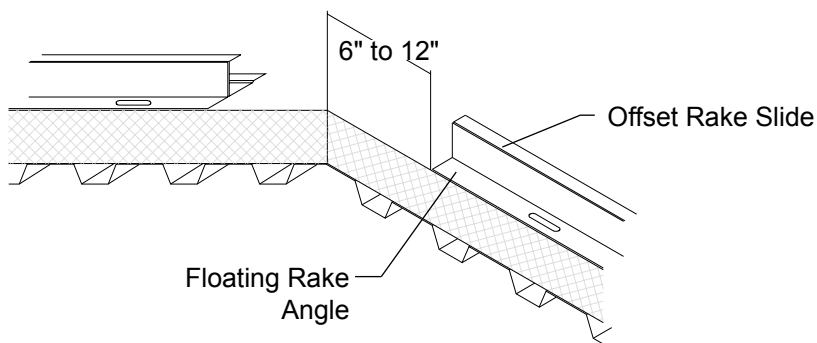

INSTALLING FIRST PANEL

STEP
3

Note: Eave, Gutter Drip, Gutter, Valley or any low side flashing must be installed prior to installation of roof panel. The following steps are for installing T-Armor from left to right. T-Armor may be installed from right to left or from the center outwards. (See page 46 for installation diagrams).

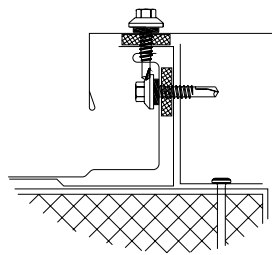

On Module

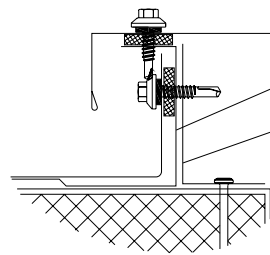

Off Module (field cut and bend)

Offset Rake Slide
Floating Rake Angle

Steps:

1. Place a row of Double Bead Tape Sealant across top of Eave flashing. Be sure to place sealant where fastener will be placed when using an Offset Cleat.
2. Position the first panel so the panel rib is on top of the Eave flashing and the panel is against the vertical leg of the Offset Rake Slide.
3. Slide the panel up the roof so it hooks onto the Offset Cleat.

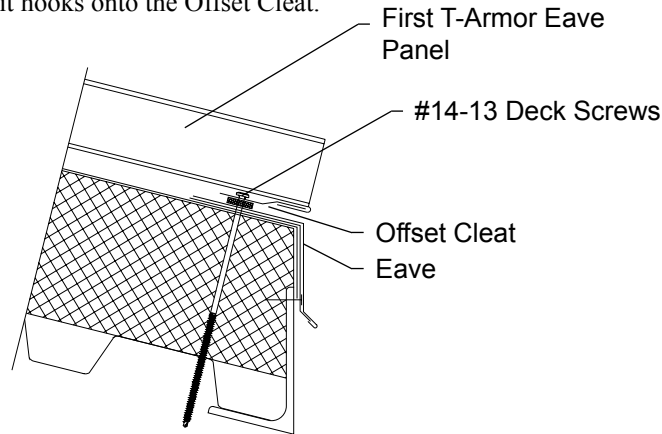

First T-Armor Eave Panel
#14-13 Deck Screws
Offset Cleat
Eave

4. Use a C-Clamp to hold the panel against the vertical leg of the Offset Rake Slide and Floating Rake Angle.
5. Recheck the panel overhang dimension at Eave, Ridge and Endlap if required, and adjust if necessary.

Note: It is critical that sealants be properly placed to prevent moisture leakage.

6. Apply two $\frac{3}{8}$ " beads of Tube Sealant along the side of the rib of the panel and across the horizontal portion of the top side of the rib directly over the Double Bead Tape Sealant on the Eave flashing. Be sure the Tube Sealant joins with the Double Bead Tape Sealant.
7. Peel back the paper backing covering the Double Bead Tape Sealant at the Eave flashing previously installed.
8. Use #12-14x $\frac{1}{4}$ " Self Driller XL screws at 1'-0" oc to fasten through the Panel, Offset Rake Slide and Floating Rake Angle.

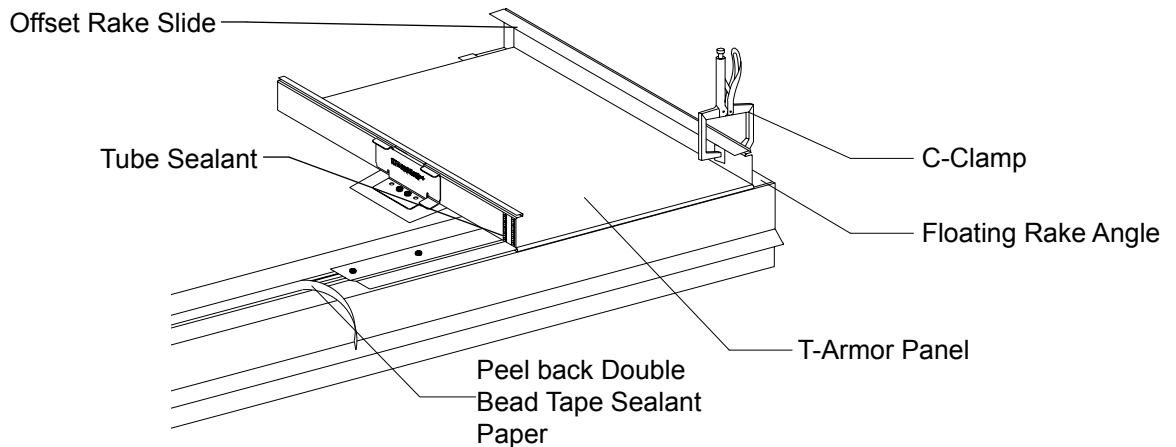

Offset Rake Slide
Tube Sealant
C-Clamp
Floating Rake Angle
T-Armor Panel
Peel back Double Bead Tape Sealant Paper

INSTALLING PANEL CLIPS

STEP 4

Note: The following procedures are based on installing panel clips over steel purlins. For fastening clips to a substructure other than steel, (see page 44). Design wind uplift requirements and insulation thickness must be considered for proper selection of clip type, size and spacing. (See Systems Components chart on page 44.)

Steps:

1. When installing over rigid insulation, bearing plates must be use at every clip location.
2. Place the panel clip in the groove of the panel rib.
3. Rotate the clip to a vertical position so that the lower tap of the clip rest under the bottom of the panel.
4. Fasten clip to metal deck with (2) #14-13 Deck Screws (length of screws will vary depending on the thickness of the roof assembly).
5. After installing clips along of the panel, measure across the pan of the panel to confirm panel modularity.

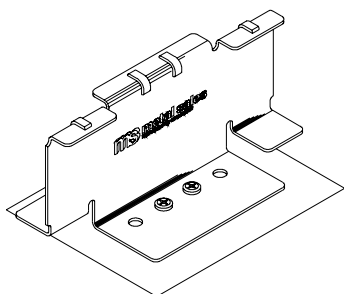

CORRECT

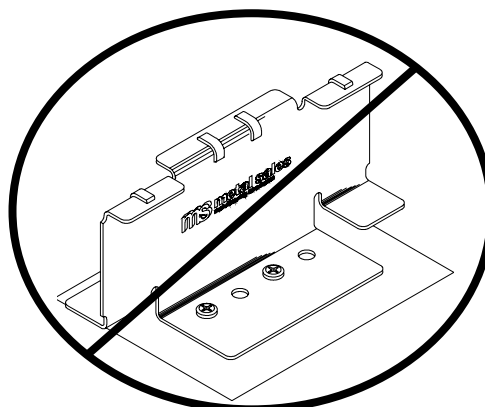
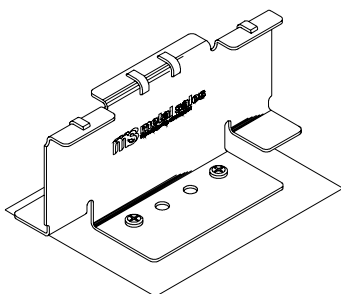

INCORRECT

Refer to the chart on page 44 for determination of the proper clip size. Correct clip size must be used for panel system to function properly.

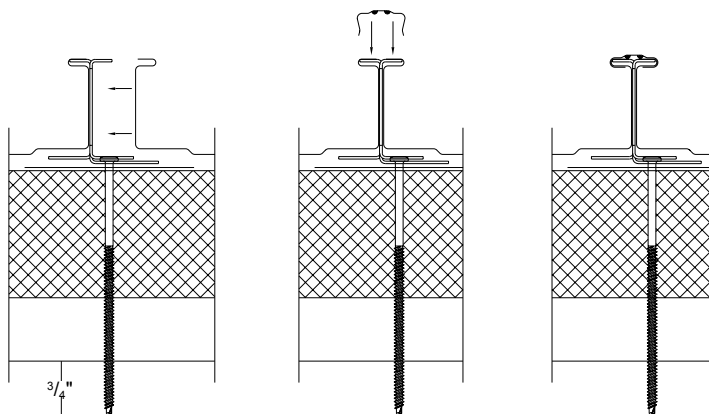

6. Slide next panel into place and place cap over both panels.
7. After second panel has been set in place, snap Cap over both panels and hand crimp in place (see page 56).

CAUTION

If a fastener strips out, you must remove the clip and reposition so the fastener can drill a new hole at least $\frac{3}{8}$ " from the stripped hole or install an oversized fastener in the stripped hole. Failure to do this will result in weakening the roof wind uplift resistance.

ENDLAPPING OF PANEL

STEP 5

Note: It is critical that panels located as detailed on erection drawings in order for panels to have adequate movement due to thermal expansion and contraction. Panels must be fixed at the eave or ridge, not both eave and ridge. Endlap splices fixed to the roof assembly below the panels. The following procedures also apply to panel runs with multiple laps. The distance between endlaps on a rib must be at least 24".



Staggered Endlaps

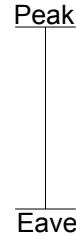

Steps:

1. The hems of the high end of the Eave Panel are factory-notched 3" to allow the Peak Panel to nest inside the Eave Panel.
2. Apply 2 rows of Endlap Pad on the notched end of the Eave Panel across panel flat.
3. Apply a row of Tube Sealant across each Endlap Pad and the side of the rib on both sides of the panels.
4. Lap the Peak Panel onto the Eave Panel the 3" length of the notch.
5. Hold the flat of the Peak Panel up and nest the legs together.
6. Nest the flat of the Peak Panel into the Eave Panel.
7. Insert Stiffener Plate into the hems of the ribs and set in Tube Sealant.
8. Apply a 2.5" Pig Tail of Endlap Pad around the hems of the panel where the panel notch occurs.
9. Install Eave Cap, ensuring the cap endlap occurs at least 1'-0" away from the panel endlap.
10. Apply Tube Sealant across each end of the cap notch.
11. Install Peak Cap.

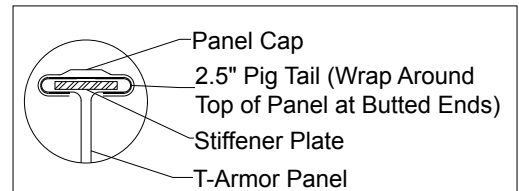
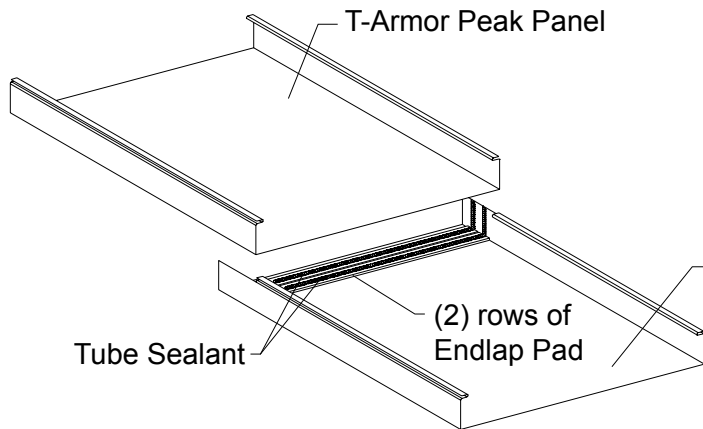

Section A-A

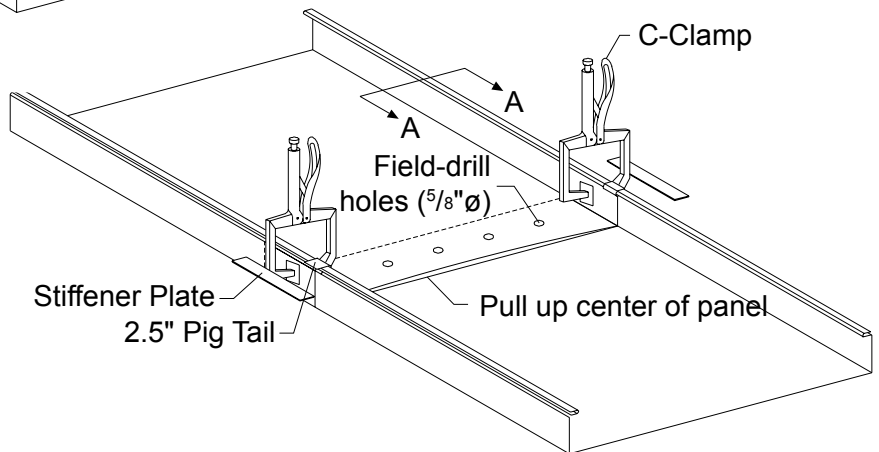

ENDLAP FASTENING PATTERN

12. Field-drill the first hole (using a 5/16" drill bit) through both panels for 9/32" Bulb-Tite Rivet fasteners (see below for number of fasteners require for each width of panel) and install first Bulb-Tite Rivet, drill second hole and install the second Bulb-Tite Rivet, continue until all fasteners have been installed.
13. Install 9/32" Bulb-Tite Rivet with hand rivet pullas as shown on page 16 or a power rivet puller where the peak panel laps over the eave panel and fasten in accordance with fastening pattern sequence shown below. Do not exceed 2.5" between Rivets.
14. Repeat these steps for subsequent endlaps.

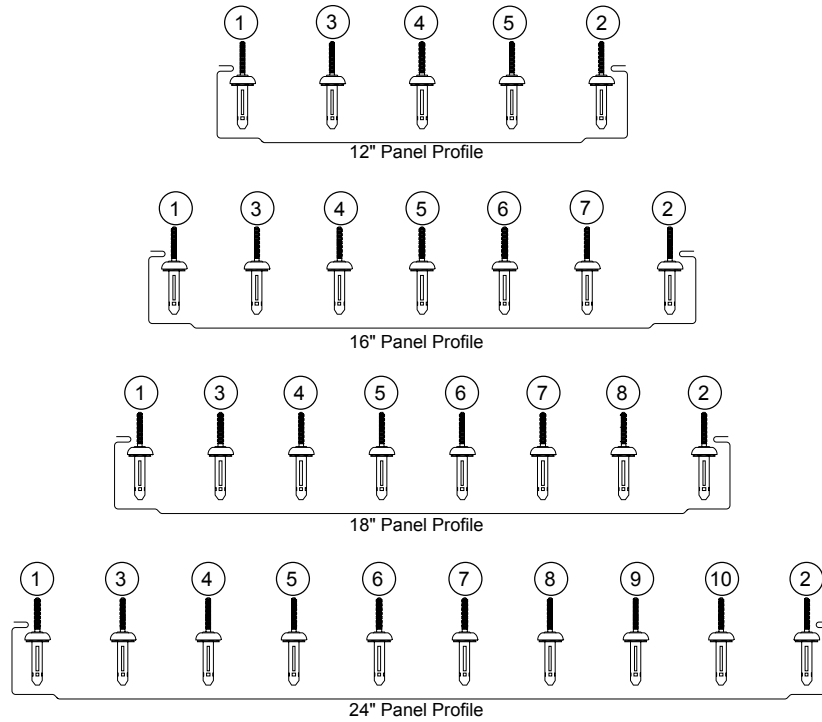

PANEL END FASTENING PATTERN

Note: Check the detail for the type of fastener required. These fasteners may be Self Drillers, Deck Screws or Bulb-Tite Rivets.

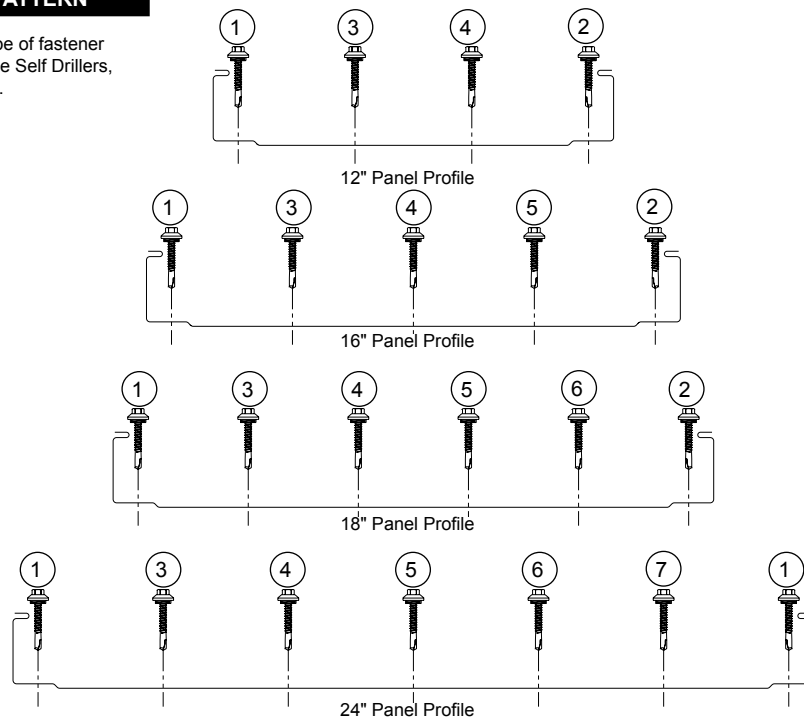

SIDELAPPING OF PANEL

**STEP
6**
Steps:

1. Apply two $\frac{3}{8}$ " beads of Tube Sealant along the vertical side of the rib on the panel and across the horizontal portion of the top side of the rib directly over the Double Bead Tape Sealant on the eave flashing. Be sure the Tube Sealant joins with the Double Bead Tape Sealant.
2. Peel back the paper backing covering the Double Bead Tape Sealant at the eave flashing previously installed.
3. Roll the female leg of the second panel into place over the male leg of the first panel so their ends are flush. Do not let the flat of the second panel touch the Double Bead Tape Sealant at the eave until the ends are flush.

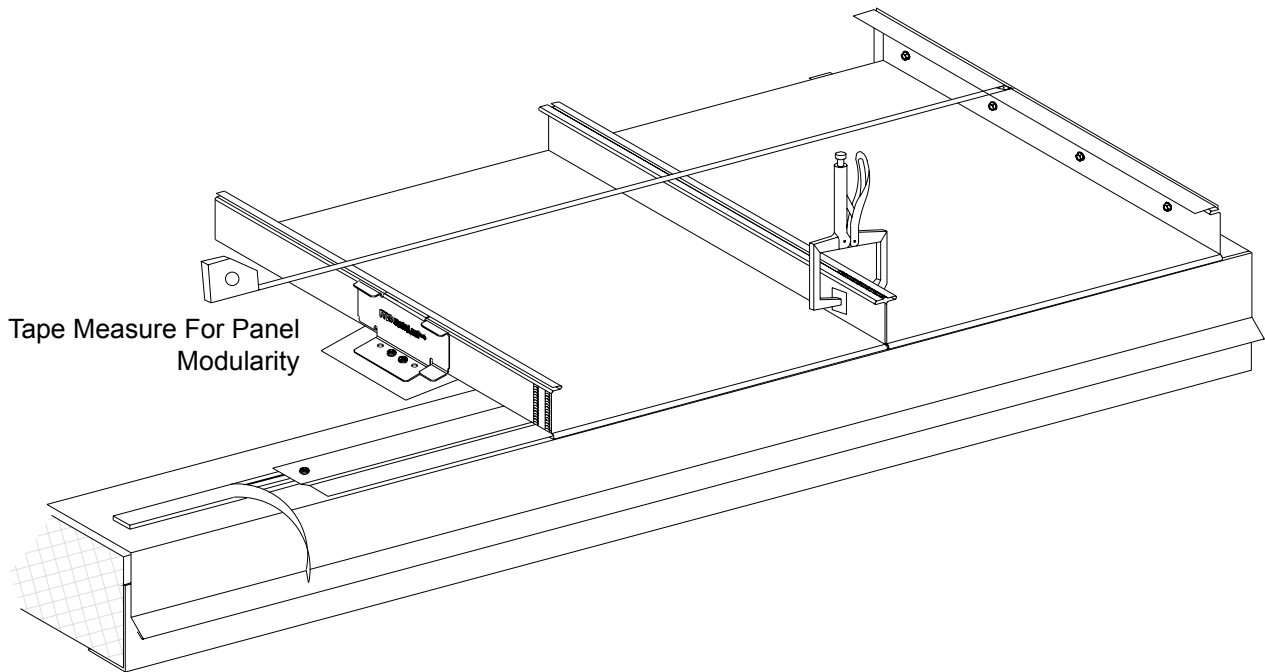

4. Use C-Clamps to hold the two vertical legs of the panel seams together.
5. Measure the distance from the first rib of the first panel installed. It is very important that the dimension from the start panel to the last male leg, at the eave and peak, be the same dimension within a $\frac{1}{4}$ " of each other.
6. Make certain that all clips are properly installed and that the panel sidelaps are properly positioned to be seamed. Use the Hand Crimper to crimp the panel seam at the eave and ridge ends only. This will adequately hold panels in place until fully seamed.

CAUTION

Hand crimping will not fasten the panels together tightly enough to withstand normal wind uplift forces. Be sure to seam all panels as soon as possible. (See seaming panels on pages 55 and 56 for proper seaming instructions.)

TERMINATION OF PANEL

STEP
7

Note: The following steps are for terminating a panel run when the pan width exceeds the remaining length of the building.

Steps:

1. When the roof panel installation has reached the opposite end of the roof, the last panel run may need to be field modified to attach to the Floating Rake Angle previously installed.
2. Measure the distance between the vertical leg of the last full panel run and the vertical leg of the Floating Rake Angle at the eave, endlap, and peak. See dimension "A".
3. Determine if a full panel will fit between the last full run and the Floating Rake Angle. In most cases it will not fit. If the full panel will fit, then continue with the installation of the roof. When the last panel is installed the vertical leg of the male side must fit flush with the Floating Rake Angle.

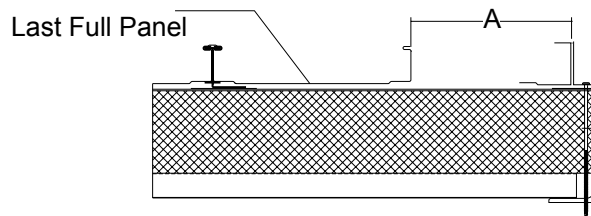

4. If a full panel is too wide to fit between the last full panel run and the Floating Rake Angle, a panel will have to be field cut and bent to simulate a male leg.
5. Use the dimension "A" and mark a line on the last panel to serve as the bend line. Mark a second line (the same dimension as the panel rib height) past the bend line to be the line you will cut off the excess panel.
6. Field-bend the roof panel up 90 degrees to from a vertical leg.
7. Place termination panel between last full panel and vertical leg of Floating Rake Angle making sure the panel fits properly.
8. Clamp termination panel to leg of Floating Rake Angle until Rake Detail is to be installed. (See page 63 for details.)

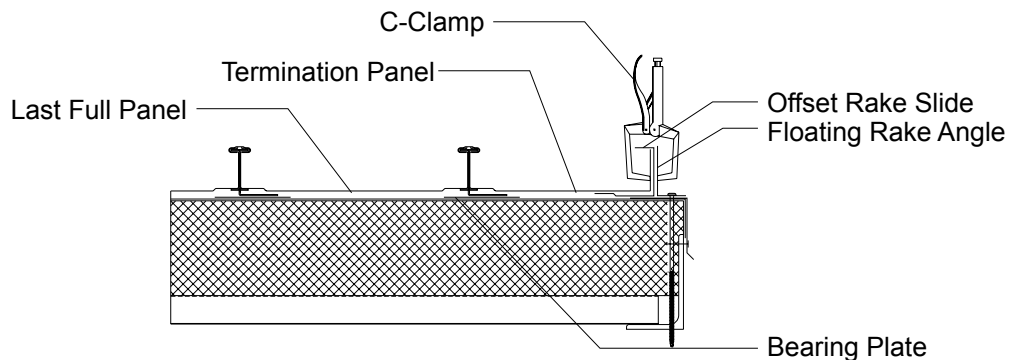
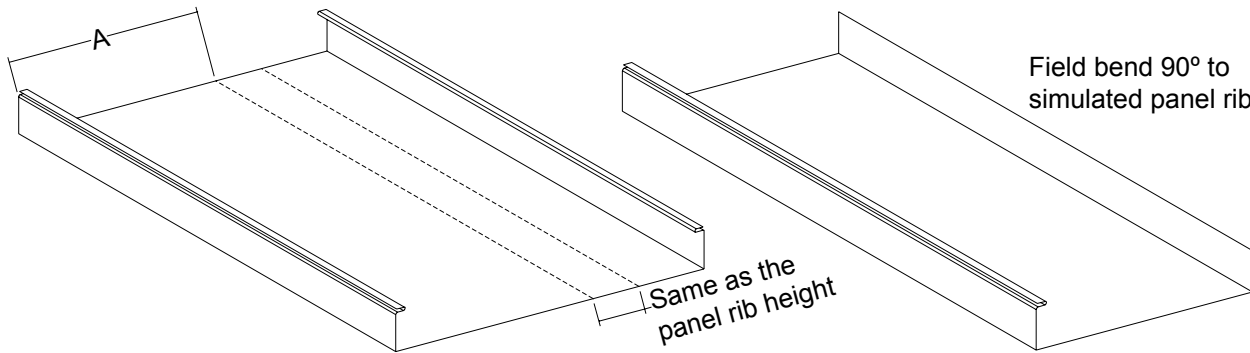

SEAMING PANELS

STEP

8

- Rental or purchase of the T-Armor mechanical seamer and hand crimpers for field-seaming are the responsibility of the installer. Mechanical seamers and hand crimpers can be acquired from:
Developmental Industries
 915 Old Highway 45 S.
 Corinth, MS 38834
 Phone No. (662) 287-6744
www.msseamers.com
- Read the field manual that is enclosed in the case with the seamer. The operator should adhere to all instructions for proper use of the seamer. Failure to follow the required instructions may result in damage to the panel and/or seamer. Metal Sales will not be responsible for damage incurred by improper use of the seamer.
- All panel sidelaps should be seamed with mechanical seamer as soon as possible, after the panels have been installed. Hand crimping the panel sidelaps 8" at the eave, endlap and ridge locations of the panel will help keep the panels in place during normal erection, but will not prevent the panels from being blown off the roof by moderate strong winds.
- At endlap conditions, panels must be handcrimped only. Mechanical seaming of panels will cause rib distortion due to multiple thicknesses along the endlap.
- Run sufficient power to the roof to operate the seamer. If the job site is a long distance from the roof or if the roof is large, consider using a portable generator placed on the roof near the seaming operation.
- Do not overload or damage the roof with the generator unit. Be sure to follow OSHA and local electrical codes when installing generator.
- Prior to seaming panels check all seams making sure they are properly engaged. All dirt, debris and excess sealant should be removed from flat part of panel and seams.

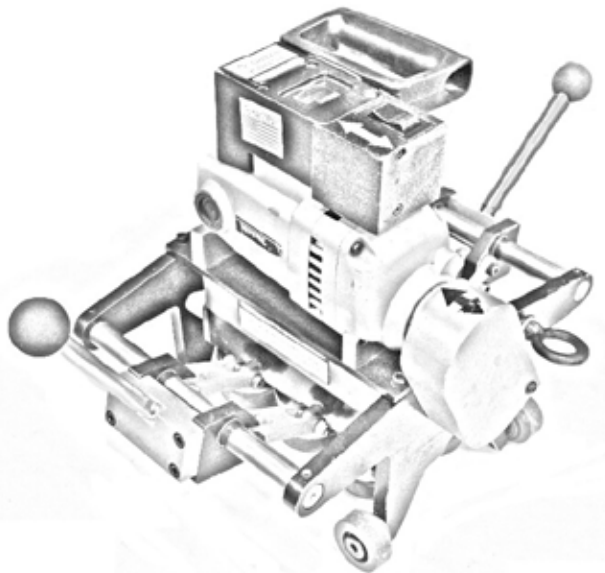

MECHANICAL SEAMER

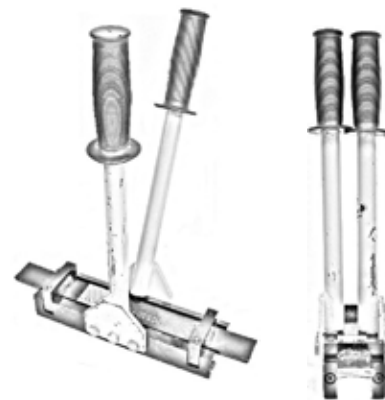

HAND CRIMPER

SEAMING PANELS (CONT.)

Steps:

1. To start seaming, hand crimp the first 8" of seam at eave, the cap endlap, and ridge locations. Other areas such as at clips may be hand crimped, but this additional hand crimping is not necessary.

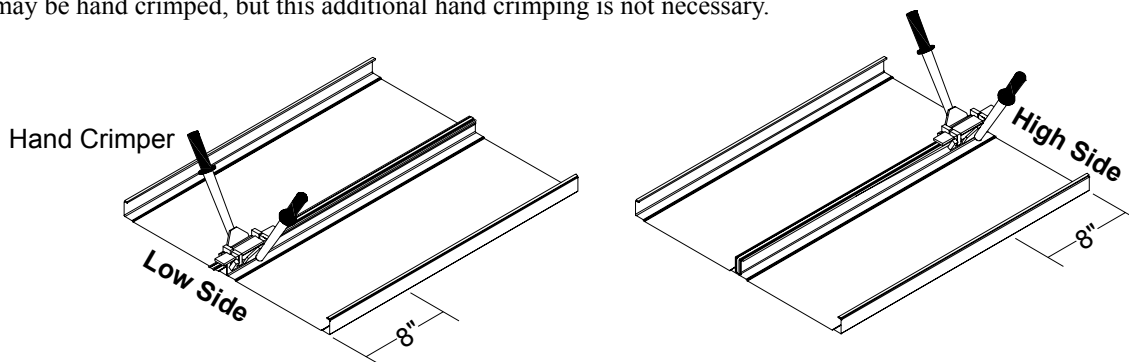

2. Position mechanical seamer over hand crimped roof seam at ridge location so that the levers are on the same side of the seam that is to be crimped by the mechanical seamer.
3. Engage roller levers on both sides of seamer.
4. Prior to running seamer, check to make sure that T-Armor panels are fully engaged along the entire run of the panel. Small C-Clamps may be required on the horizontal portion of the seam to hold panel seam engaged while seaming.

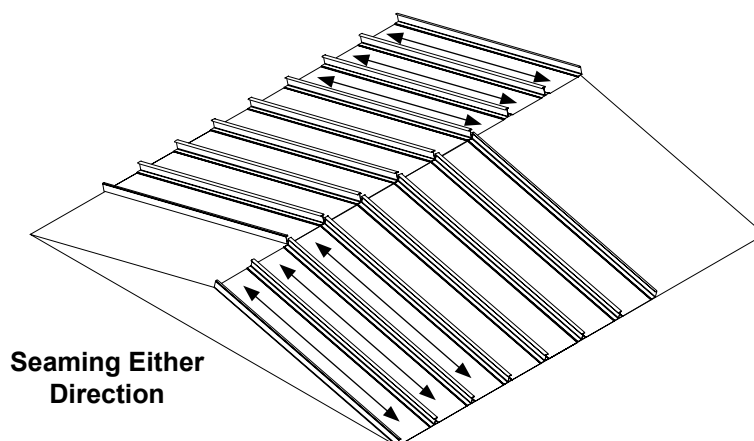

5. Turn on the power to seamer and walk with the seamer as it seams the panel. Stop the seamer in the first few feet to ensure proper seam is being achieved. Turn the mechanical seamer off before the hand crimped end portion of the panel. Remaining seam between hand crimped portion and mechanically seamed portion may have to be hand crimped for continuous tight seam.
6. At the end of the first run, remove mechanical seamer and return to step #1 for remaining panels.
7. At completion of seaming, repack tool and return to Developmental Industries, 915 Old Highway 45 S, Corinth, MS 38834. Phone No. (662) 287-6744.

NOTE:

Contact your local sales branch (see page 2) for directions concerning proper removal of damaged panels and installation of replacement panels. See page 79 for instruction on panel removal

CAUTION

Do not run the seamer off the end of the panel. If the seamer is run off the end of the roof it could cause injury to personnel and damage the roof or the seamer. (See seamer instructions enclosed in the case for additional information about the proper handling of the seamer.)

**1/2:12 Slope
Minimum**

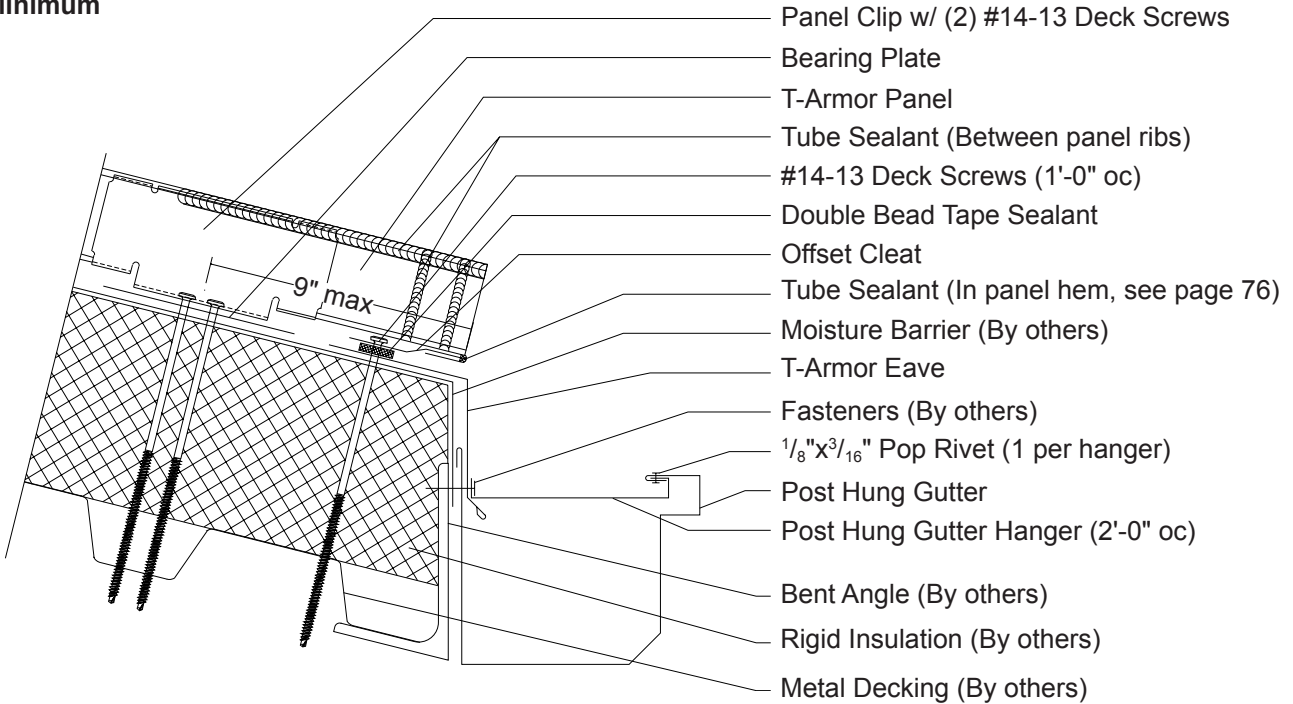

Panel cap not shown for clarity.
For High Clips, install High Eave Plate before T-Armor Eave.

CAUTION

In locations where heavy rainfall or severe ice and snow may occur, Metal Sales' standard gutters may not be suitable for use.

INSTALLATION NOTES

All T-Armor Eave must be installed prior to panel installation.

1. Install new T-Armor Eave over top of rigid board insulation to hold T-Armor Eave into place, fasten to substrate at 4'-0" oc.
2. Apply a continuous row of Double Bead Tape Sealant across the T-Armor Eave.
3. Install Offset Cleat at Double Bead Tape Sealant locations and secure with #14-13 Deck Screws at 1'-0" oc.
4. Install the panels by hooking the hemmed edge of the panel (see 76 for Hemming Instructions) around the end of the Offset Cleat.
5. Apply Tube Sealant up the side and across the top of the panel ribs before installing the next panel.
6. Install the Post Hung Gutter by sliding it behind the T-Armor Eave. Install the Post Hung Gutter Hanger at 2'-0" oc fastening through the T-Armor Eave into the roof framing.
7. If two or more flashings are required, lap the flashing over the previously installed flashing by a minimum of 2" placing two rows of Tube Sealant between the flashings and secure with Pop Rivets, 2.5" oc.

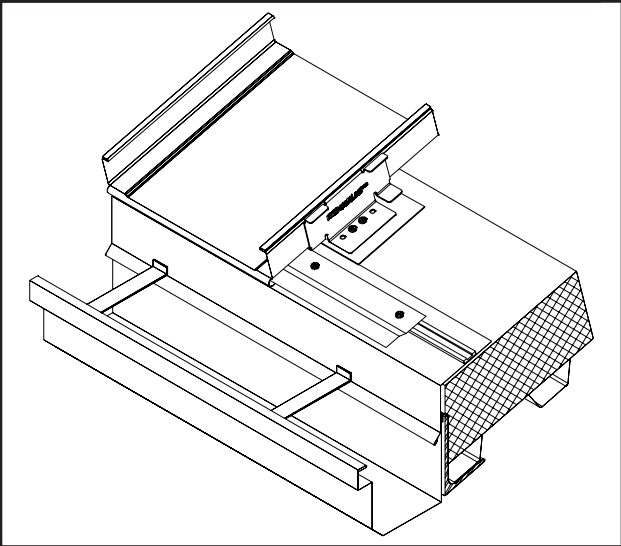

**1/2:12 Slope
Minimum**

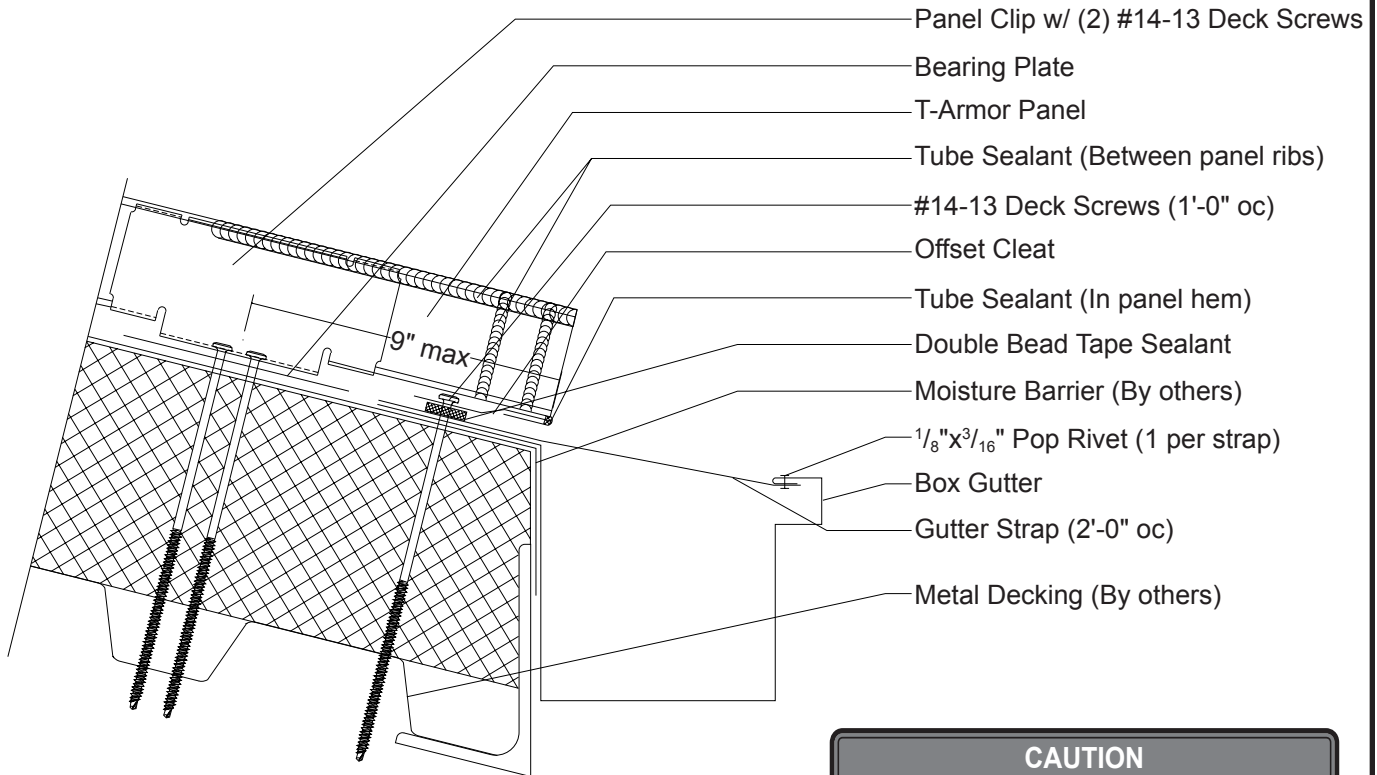

Panel cap not shown for clarity.
For High Clips, install High Eave
Plate before T-Armor Eave.

CAUTION
In locations where heavy rainfall or severe ice and snow may occur, Metal Sales' standard gutters may not be suitable for use.

INSTALLATION NOTES

All gutter flashings must be installed prior to panel installation.

1. Install new Box Gutter over top of rigid board insulation. To hold Box Gutter in place fasten to substrate with fasteners 4'-0" oc.
2. Apply a continuous row of Double Bead Tape Sealant across the Box Gutter.
3. If two or more flashings are required, lap the flashing over the previously installed flashing by a minimum of 2" placing two rows of Tube Sealant between the flashings and secure with Pop Rivets, 2.5" oc.
4. Field-bend and place Gutter Straps at 2'-0" oc (maximum).
5. Install Offset Cleat at Double Bead Tape Sealant locations and secure with #14-13 Deck Screws at 1'-0" oc.
6. Install the panels by hooking the hemmed edge of the panel (see page 76 for Hemming Instructions) around the end of the Offset Cleat.
7. Apply Tube Sealant up the side and across the top of the panel ribs before installing the next panel.

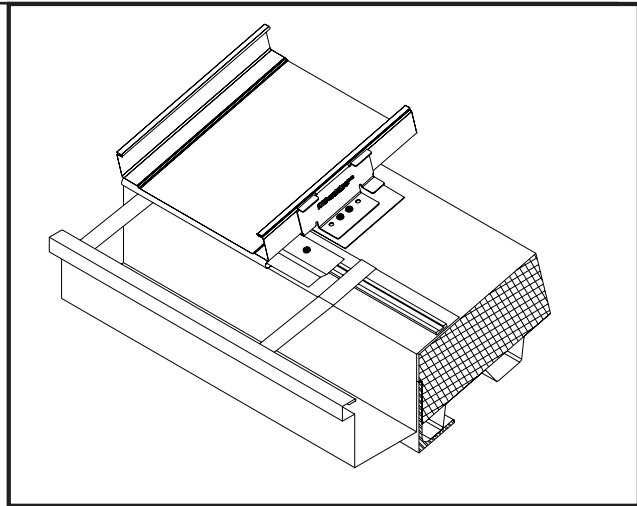

**1/2:12 Slope
Minimum**

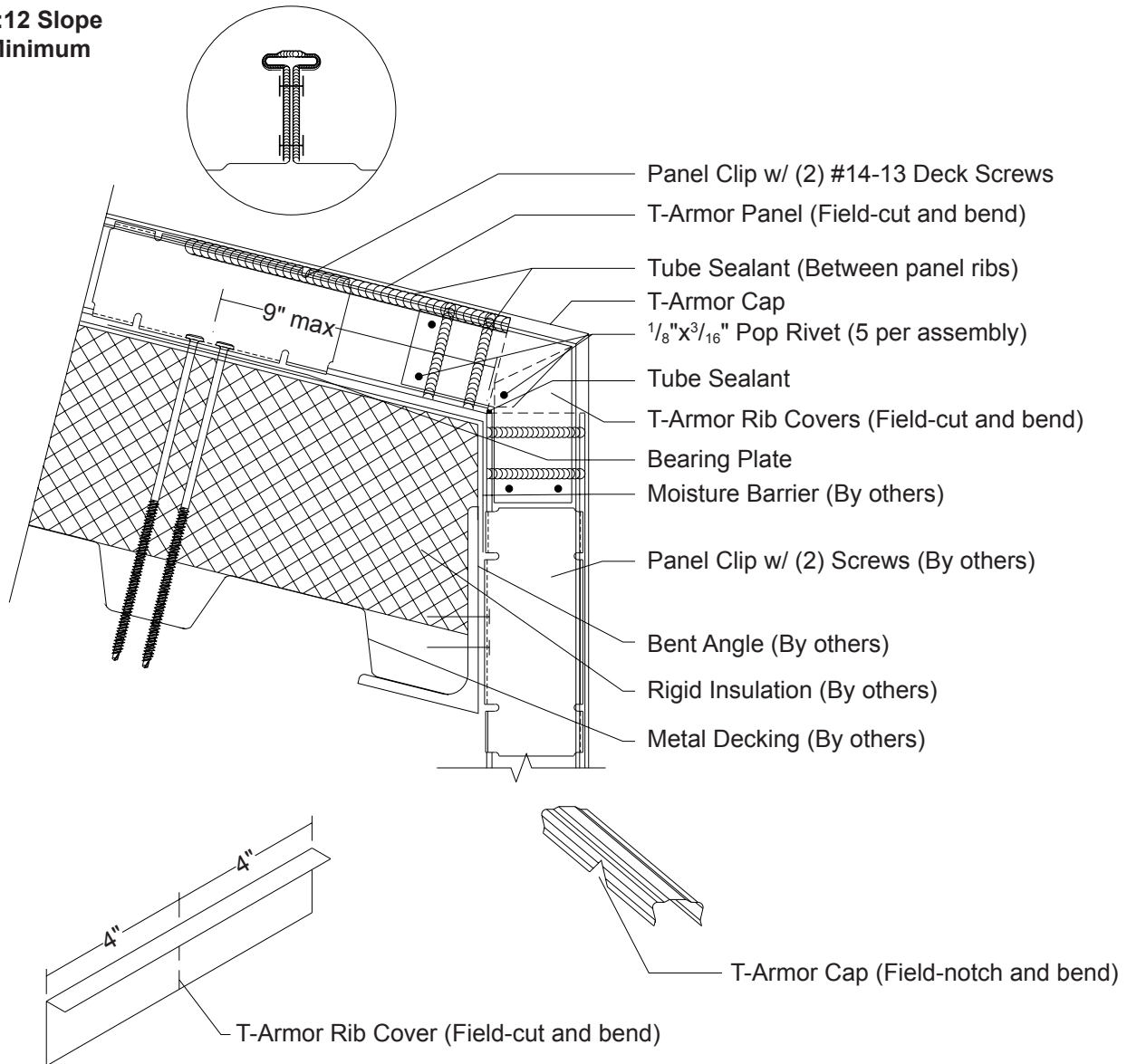

INSTALLATION NOTES

NOTE:

Longer Pop Rivets may be required depending on the thickness of the materials being used.

1. Field-cut the panel ribs and bend pan of panel.
2. Set panel on the roof substrate and apply panel clip 6" maximum from the end of the roof.
3. Apply four rows of Tube Sealant (2 on either side of the cut) up the side of the panel rib.
4. Field-cut and bend T-Armor Rib Covers (2 required for each rib), and fasten with 5 Pop Rivets per connection.
5. Field-notch panel Cap and bend, set on top of panel rib and hand crimp into place.
6. Fill any gaps or opening with Tube Sealant.

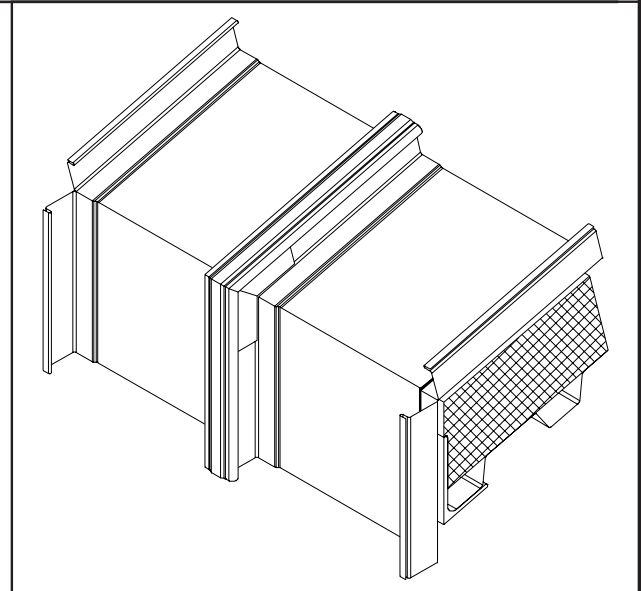

**1/2:12 Slope
Minimum**

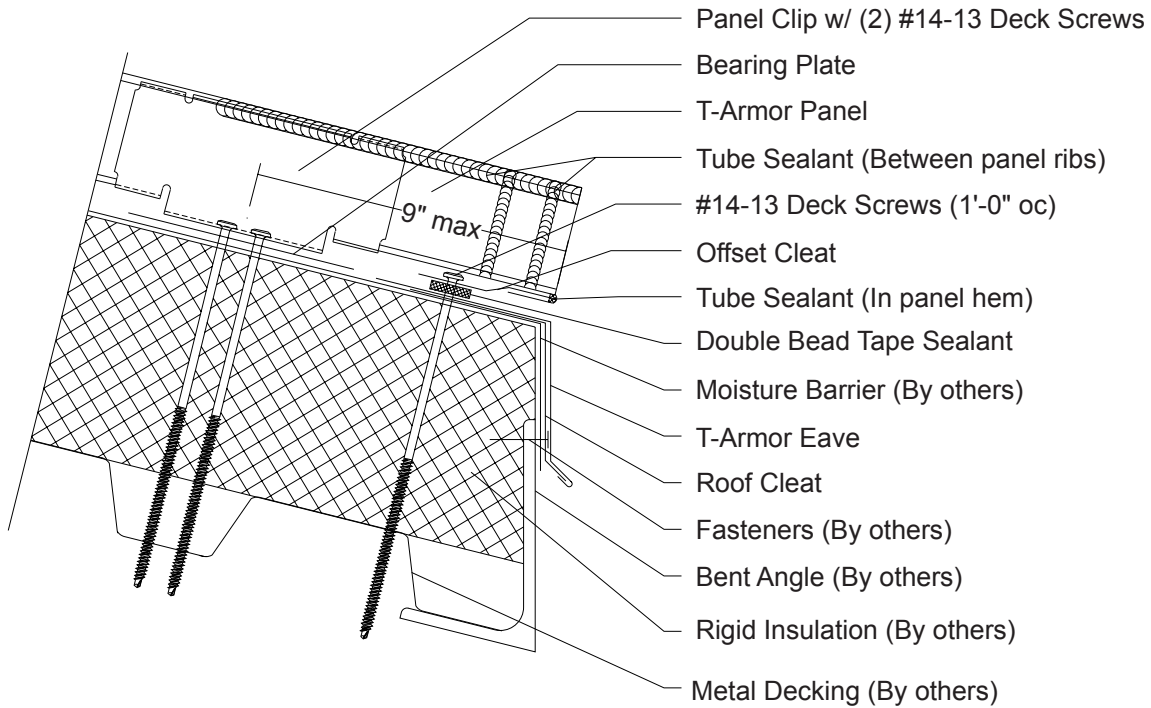

Panel cap not shown for clarity.
 For High Clips, install High Eave
 Plate before T-Armor Eave.

INSTALLATION NOTES

All T-Armor Eave must be installed prior to panel installation.

1. Install new Roof Cleat by fastening to substrate at 4'-0" oc.
2. Install new T-Armor Eave by engaging Roof Cleat and rotating on to rigid board insulation. To hold T-Armor Eave in place fasten to substrate at 4'-0" oc.
3. If two or more flashings are required, lap the flashing over the previously installed flashing by a minimum of 2" placing two rows of Tube Sealant between the flashings and secure with Pop Rivets, 2.5" oc.
4. Apply a continuous row of Double Bead Tape Sealant across the T-Armor Eave.
5. Install Offset Cleat on Double Bead Tape Sealant locations and secure with #14-13 Deck Screws at 1'-0" oc.
6. Install the panels by hooking the hemmed edge of the panel (see page 76 for Hemming Instructions) around the end of the Offset Cleat.
7. Apply Tube Sealant up the side and across the top of the panel ribs before installing the next panel.

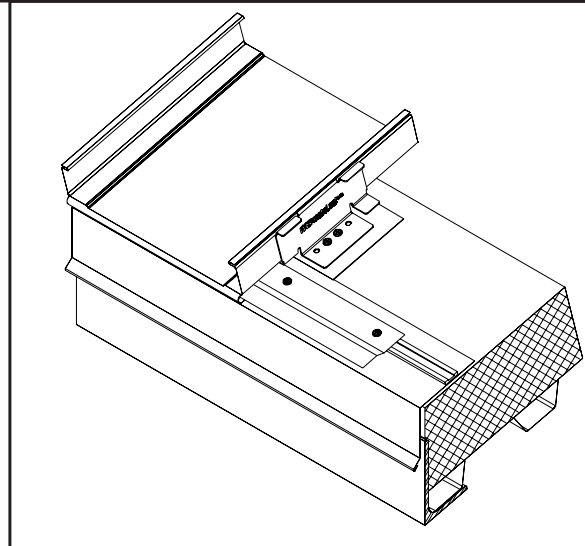

**3:12 Slope
Minimum**

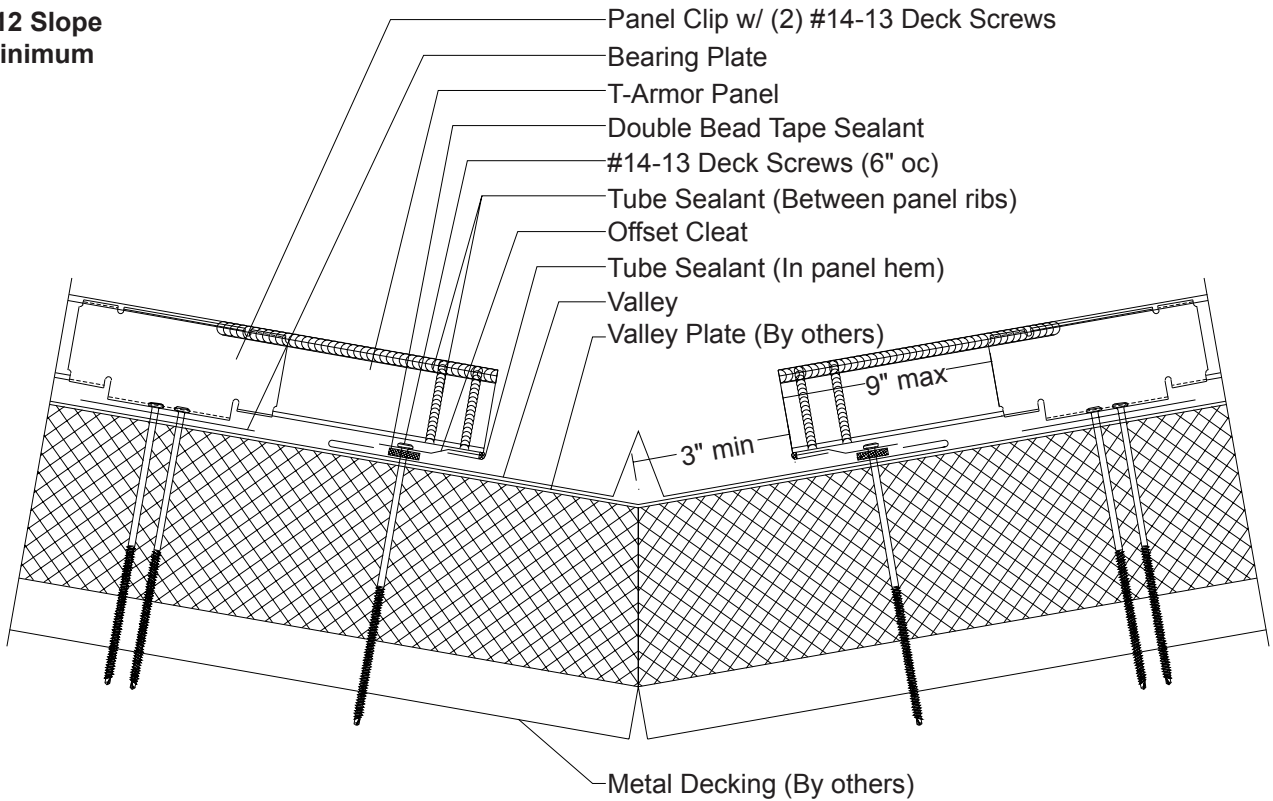

Panel cap not shown for clarity.
 For High Clips, use Drop Valley on
 High Eave Plates.

INSTALLATION NOTES

All valley flashings must be installed prior to panel installation.

1. Install new Valley over top of rigid board insulation. To hold Valley in place fasten to substrate with fasteners at 4'-0" oc.
2. If two or more flashings are required, lap the upslope flashing over the previously installed flashing by a minimum of 6" placing two rows of Tube Sealant between the flashings. Locate beads of Tube Sealant so that it does not press out of the lap. Do not install any fasteners through the Valley lap.
3. Apply a continuous row of Double Bead Tape Sealant across each side of the Valley.
4. Install Offset Cleats on Double Bead Tape Sealant and secure with #14-13 Deck Screws at 6" oc.
5. Install the panels by hooking the hemmed edge of the panel (see page 76 for Hemming Instructions) around the end of the Offset Cleats.
6. Apply Tube Sealant up the side and across the top of the panel ribs before installing the next panel.

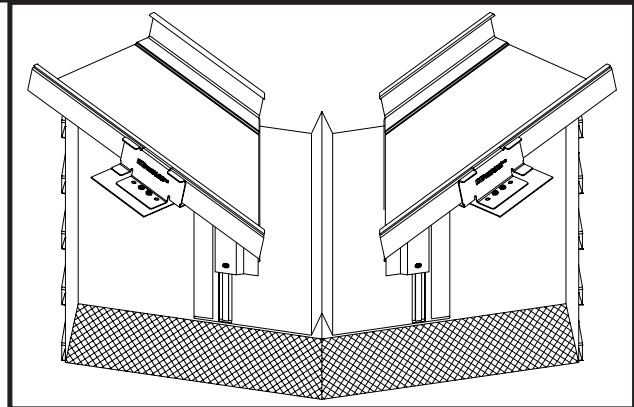

**1/2:12 Slope
Minimum**

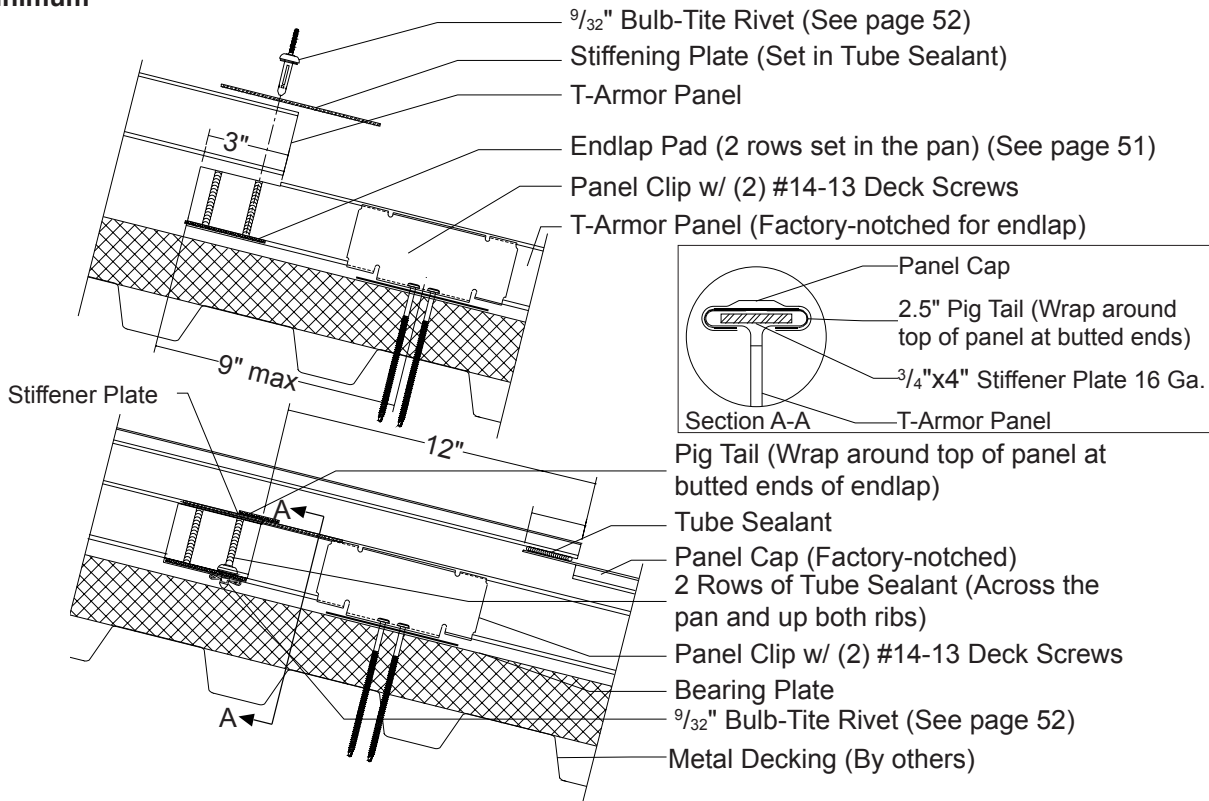

This detail should only be used with Low or High Clips.

INSTALLATION NOTES

Note: Panel Endlaps must be staggered a minimum of 24" and must be hand crimped. Do not run the mechanical seamer over the Endlap.

1. Once the Eave Panel has been installed, apply two rows of Endlap Pad (see page 51) across flat pan of the panel.
2. Apply a bead of Tube Sealant across each Endlap Pad and up both vertical ribs.
3. Set the Peak Panel into place and nest with Eave Panel so that the 3" factory notch is completely covered. (See page 51 for complete details on installing endlapped panels.)
4. Apply a bead of Tube Sealant at the butted ends of the panel hems. Insert Stiffener Plate into butted panel hems and set in the Tube Sealant.
5. Apply 2.5" Pig Tail of Endlap Pad and wrap around top of panel at butted ends, contacting Tube Sealant on the panel rib.
6. Use a C-Clamp to hold panels in place. Drill hole and install 9/32" Bulb-Tite Rivets (see page 52 for number of fasteners and order).
7. Install Eave Cap, apply a bead of Tube Sealant across the width of the end of the notch and install the Peak Cap. The Cap endlap must be located a minimum of 12" away from the panel endlap.

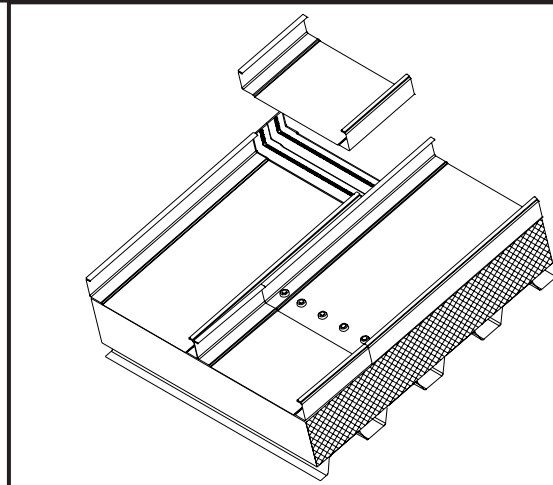

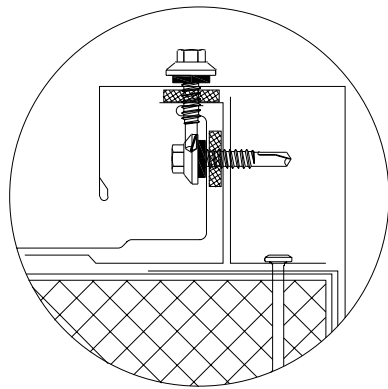

ON MODULE

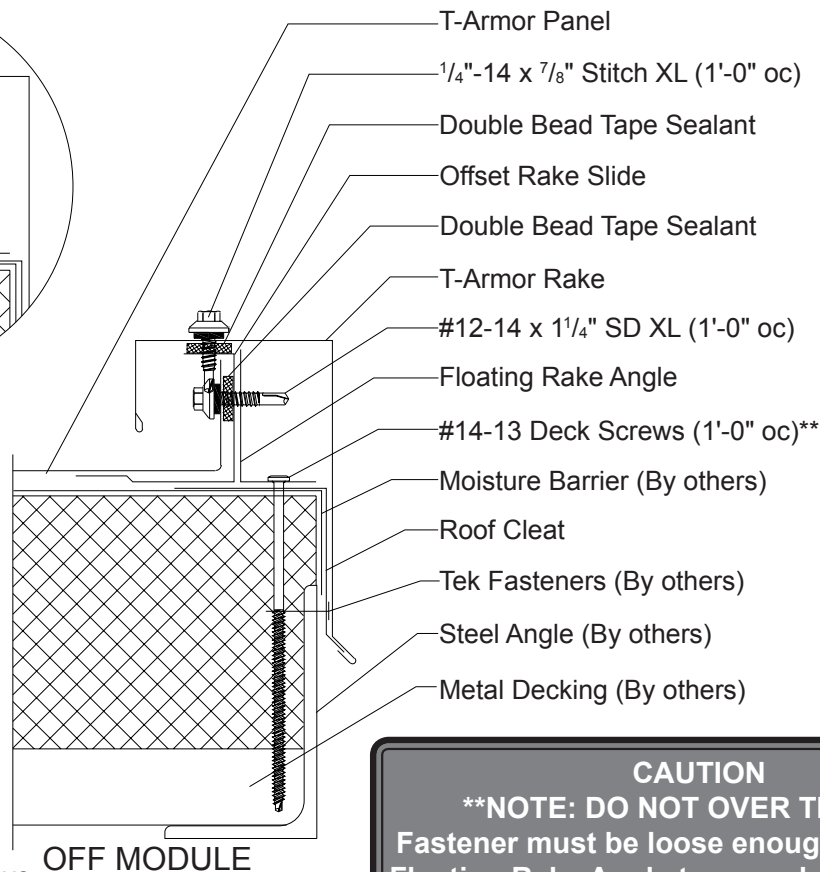

Field-close Rake at the Eave.
(low end of the flashing run)

CAUTION
****NOTE: DO NOT OVER TIGHTEN.**
 Fastener must be loose enough to allow for Floating Rake Angle to move back and forth.

INSTALLATION NOTES

Floating Rake Angle and T-Armor panels must be installed prior to T-Armor Rake installation (See pages 47-56).

1. Install Roof Cleat on top of rigid insulation. To hold flashing in place fasten to substrate with fasteners at 4'-0" oc.
2. With T-Armor panel properly nested beside Offset Rake Slide, apply a row of Double Bead Tape Sealant across upper side of Offset Rake Slide.
3. Fasten through Offset Rake Slide, Tape Sealant, panel and into Floating Rake Angle with #12-14 x 1 1/4" Self Driller XL screws, 1'-0" oc.
4. Apply row of Double Bead Tape Sealant on top of Offset Rake Slide.
5. Install T-Armor Rake so that the top of the flashing is flush with top of Offset Rake Slide and panel rib. Fasten through T-Armor Rake, Tape Sealant and into Offset Rake Slide with 1/4"-14 x 7/8" Stitch XL screws, 1'-0" oc.
6. If two or more flashings are required, lap the flashing over the previously installed flashing by a minimum of 2" placing a bead of Tube Sealant between the flashings and secure with Pop Rivets, 2.5" oc.

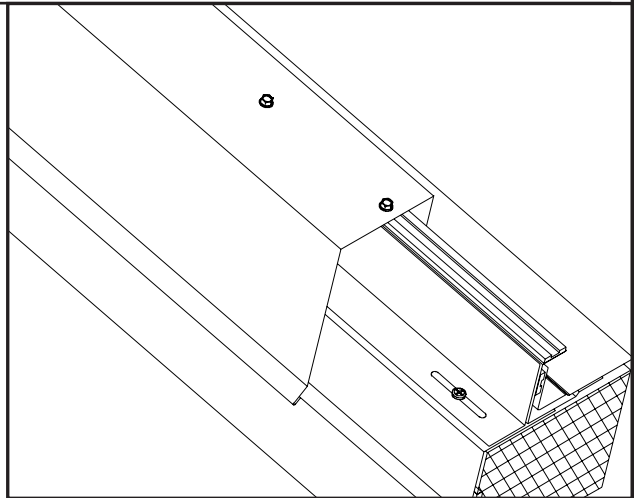

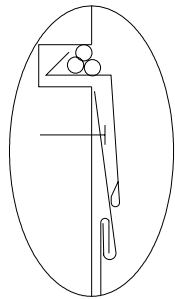

With Reglet

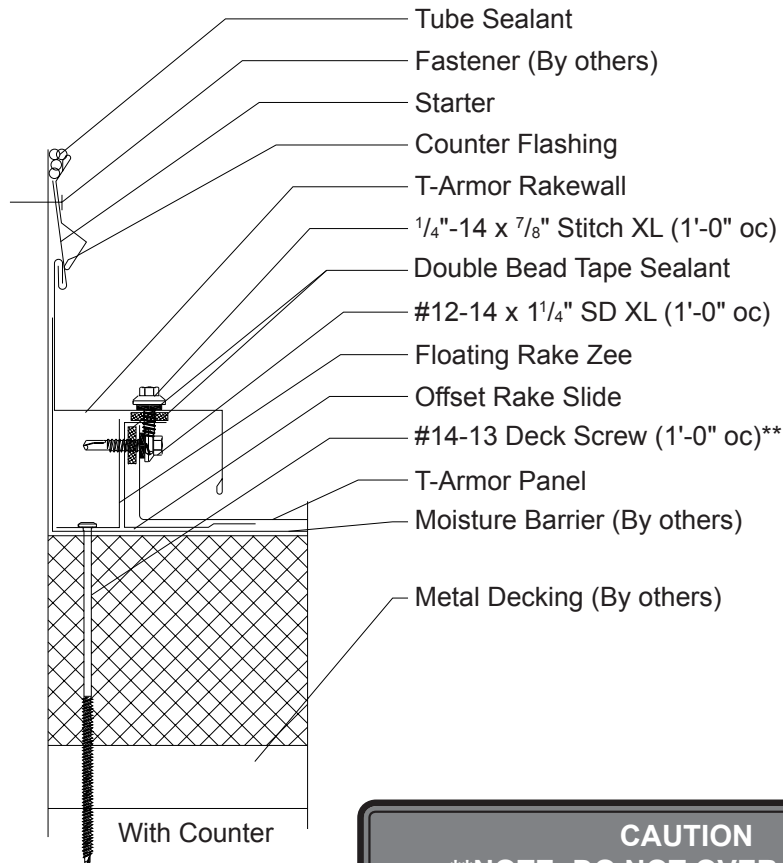

With Counter

CAUTION
****NOTE: DO NOT OVER TIGHTEN.**
 Fastener must be loose enough to allow for Floating Rake Angle to move back and forth.

INSTALLATION NOTES

Floating Rake Angle and T-Armor panels must be installed prior to T-Armor Rakewall installation (See pages 47-56).

1. With T-Armor panel properly nested beside Offset Rake Slide, apply a row of Double Bead Tape Sealant across upper side of Offset Rake Slide.
2. Fasten through Offset Rake Slide, Tape Sealant, panel and into Floating Rake Angle with #12-14 x 1 1/4" Self Driller XL screws, 1'-0" oc.
3. Apply row of Double Bead Tape Sealant on top of Offset Rake Slide.
4. Install T-Armor Rakewall so that top of the flashing is flush with top of Offset Rake Slide and panel rib. Fasten through T-Armor Rakewall, Tape Sealant and into Offset Rake Slide with 1/4"-14 x 7/8" Stitch XL screws, 1'-0" oc.
5. Install Counter Flashing, Reglet or wall panel and fasten to parapet wall with appropriate fastener, 1'-0" oc. If Counter Flashing or Reglet is used, seal to wall with Tube Sealant. **Do NOT fasten T-Armor Rakewall to parapet wall.**
6. If two or more flashings are required, lap the upslope flashing over the previously installed flashing by a minimum of 2" placing a bead of Tube Sealant between the flashings and secure with Pop Rivets, 2.5" oc.

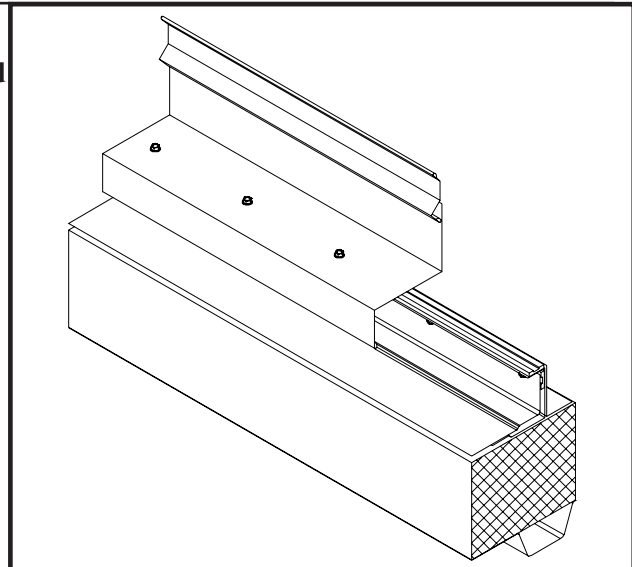

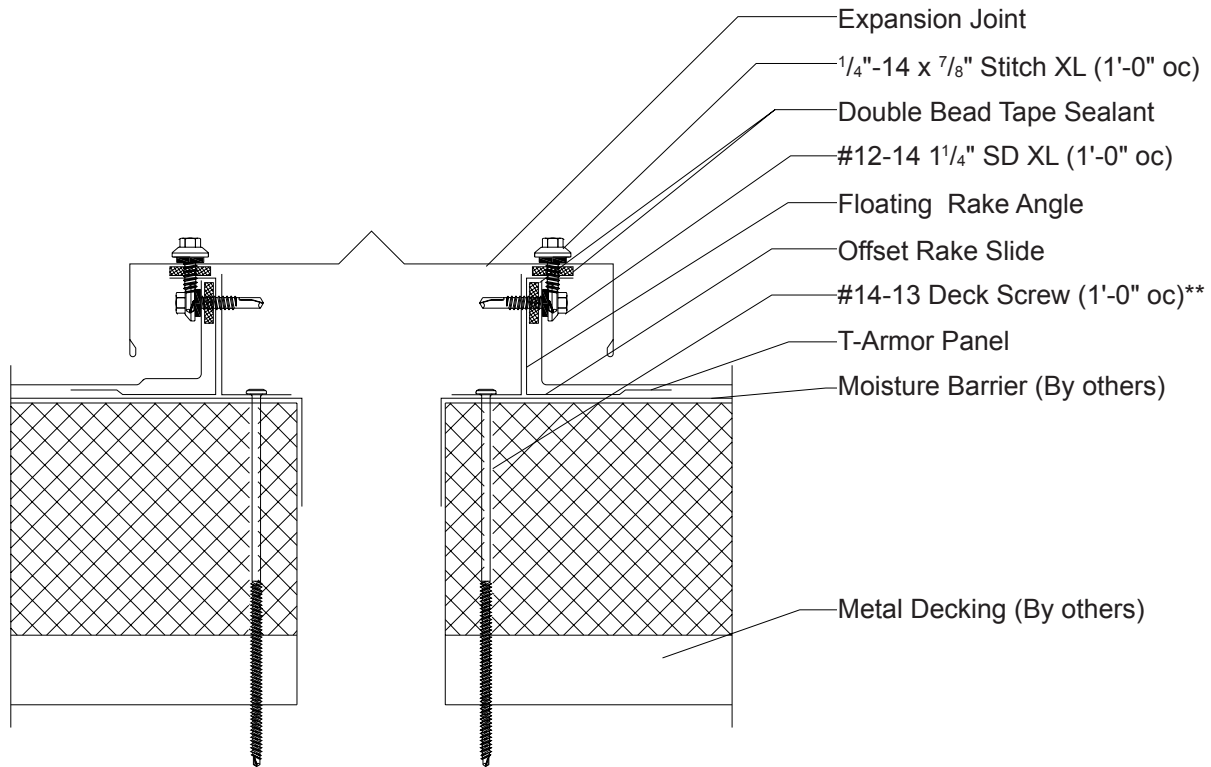

CAUTION
****NOTE: DO NOT OVER TIGHTEN.**
 Fastener must be loose enough to allow for Floating Rake Angle to move back and forth.

INSTALLATION NOTES

Floating Rake Angle and T-Armor panels must be installed prior to Expansion Joint installation (See pages 47-56).

1. With T-Armor panel properly nested beside Offset Rake Slide, apply a row of Double Bead Tape Sealant across upper side of Offset Rake Slide.
2. Fasten through Offset Rake Slide, Tape Sealant, panel and into Floating Rake Angle with #12-14 x 1 1/4" Self Driller XL screws, 1'-0" oc.
3. Apply row of Double Bead Tape Sealant on top of Offset Rake Slide.
4. Install Expansion Joint so that top of the flashing is flush with top of Offset Rake Slide and panel rib. Fasten through Expansion Joint, Tape Sealant and into Offset Rake Slide with 1/4"-14 x 7/8" Stitch XL screws, 1'-0" oc.
5. If two or more flashings are required, lap the upslope flashing over the previously installed flashing by a minimum of 2" placing a bead of Tube Sealant between the flashings and secure with Pop Rivets, 2.5" oc.

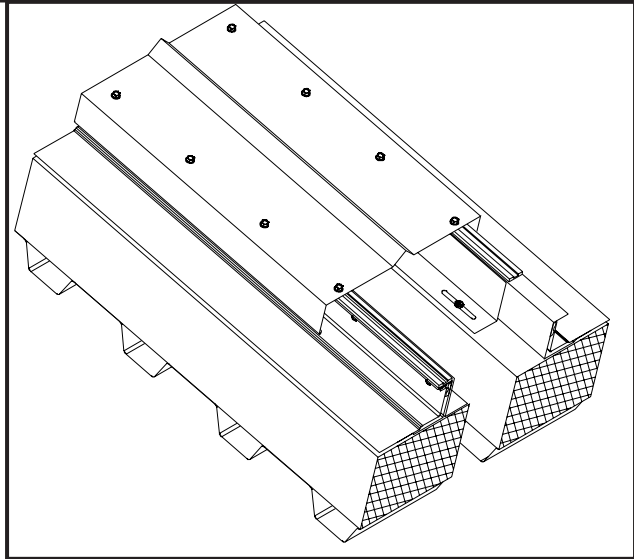

**1/2:12 Slope
Minimum**

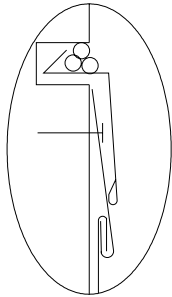

With Reglet

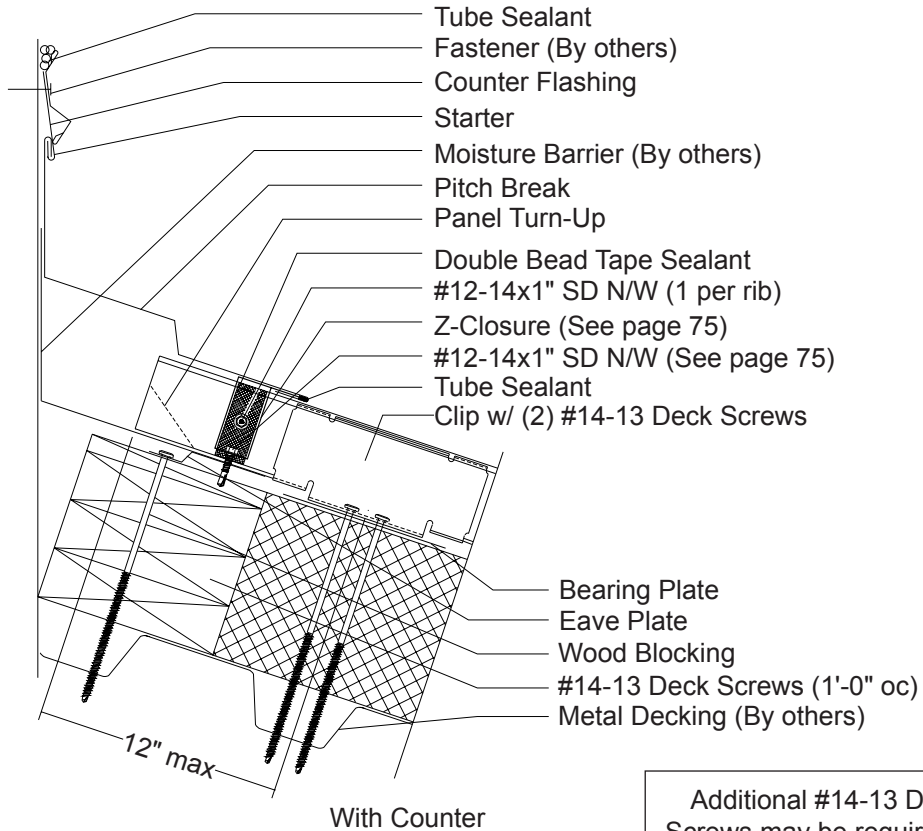

With Counter

Additional #14-13 Deck Screws may be required for areas with large snow loads.

Panel cap not shown for clarity.

INSTALLATION NOTES

1. Install Eave Plate and fasten through wood blocking and into metal deck with #14-13 Deck Screws at 1'-0" oc. If more than one Eave Plate is required then butt the ends together.
2. Place panels on to the Eave Plate and apply a row of Double Bead Tape Sealant across panel, up and over all ribs approximately 2" to 3" from panel end.
3. Field-cut Z-Closure to fit between the panel ribs, install Z-Closure over Tape Sealant. Before continuing make sure Z-Closure placement will accommodate Pitch Break.
4. Once Z-Closure is set in Tape Sealant, fasten through Z-Closure, Tape Sealant, T-Armor panel and into the Eave Plate with #12-14x1" Self Driller N/W screws (see page 75 for number and location of fasteners required).
5. Install Pitch Break by applying Double Bead Tape Sealant to the top of the Z-Closure and hooking the open hem around the Z-Closure. Fasten into the wall substrate with fasteners at 1'-0" oc maximum.
6. If two or more flashings are required, lap the flashing over the previously installed flashing by a minimum of 2" placing a bead of Tube Sealant between the flashings and secure with Pop Rivets, 2.5" oc.
7. Install Counter Flashing, Reglet, or wall panel and fasten to parapet wall with appropriate fastener, 1'-0" oc. If Counter Flashing or Reglet is used, seal at wall with Tube Sealant.

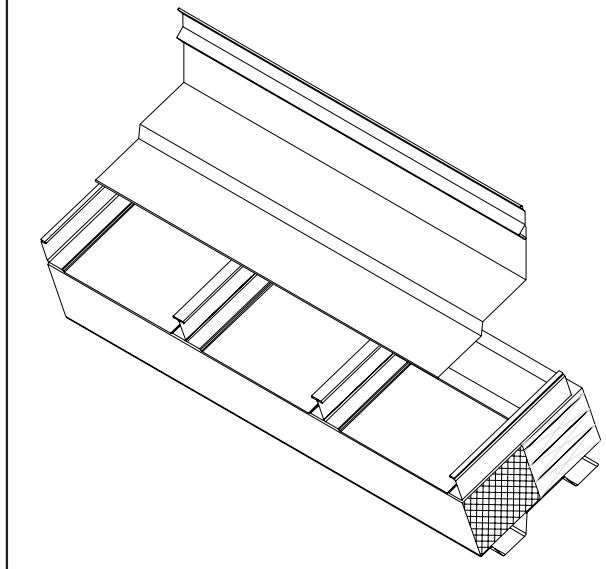

**1/2:12 Slope
Minimum**

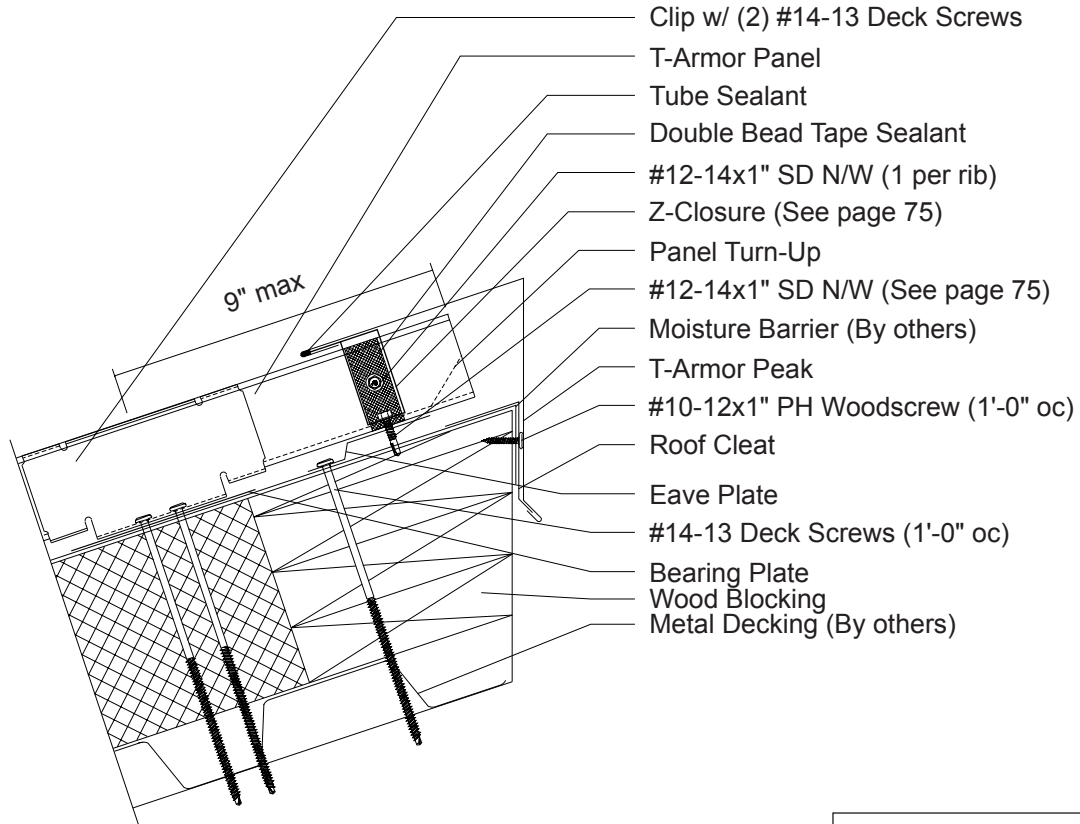

Panel cap not shown for clarity.

Additional #14-13 Deck Screws may be required for areas with large snow loads.

INSTALLATION NOTES

1. Install Roof Cleat and secure with #10-12x1" PH Wood Screws spaced 1'-0" oc.
2. Install Eave Plate and fasten into place with #14-13 Deck Screws at 1'-0" oc. If more than one Eave Plate is required then butt the ends together.
3. Place panels on the Eave Plate and apply a row of Double Bead Tape Sealant across panel, up and over all ribs approximately 2" to 3" from panel end.
4. Field-cut Z-Closure to fit between the panel ribs. Install Z-Closure over Tape Sealant. Before continuing, make sure Z-Closure placement will accommodate T-Armor Peak.
5. Once Z-Closure is set in Tape Sealant, fasten through Z-Closure, Tape Sealant, T-Armor panel and into the Eave Plate with #12-14x1" Self Driller N/W screws (see page 75 for number and location of fasteners required).
6. Apply Double Bead Tape Sealant on top of Z-Closure and install T-Armor Peak by hooking the open hem around the Z-Closure and engaging with Roof Cleat.
7. If two or more flashings are required, lap the flashing over the previously installed flashing by a minimum of 2" placing a bead of Tube Sealant between the flashings and secure with Pop Rivets, 2.5" oc.

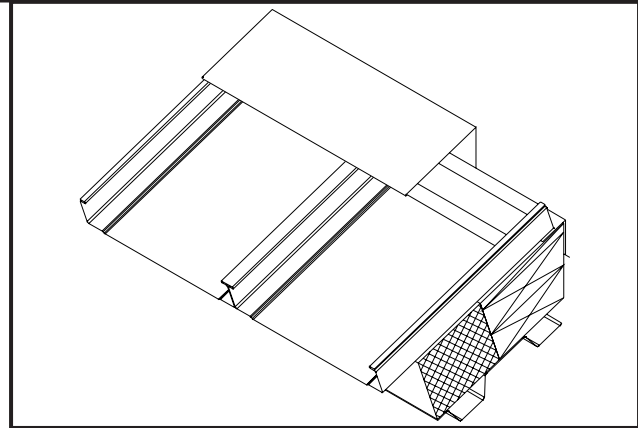

**1/2:12 Slope
Minimum**

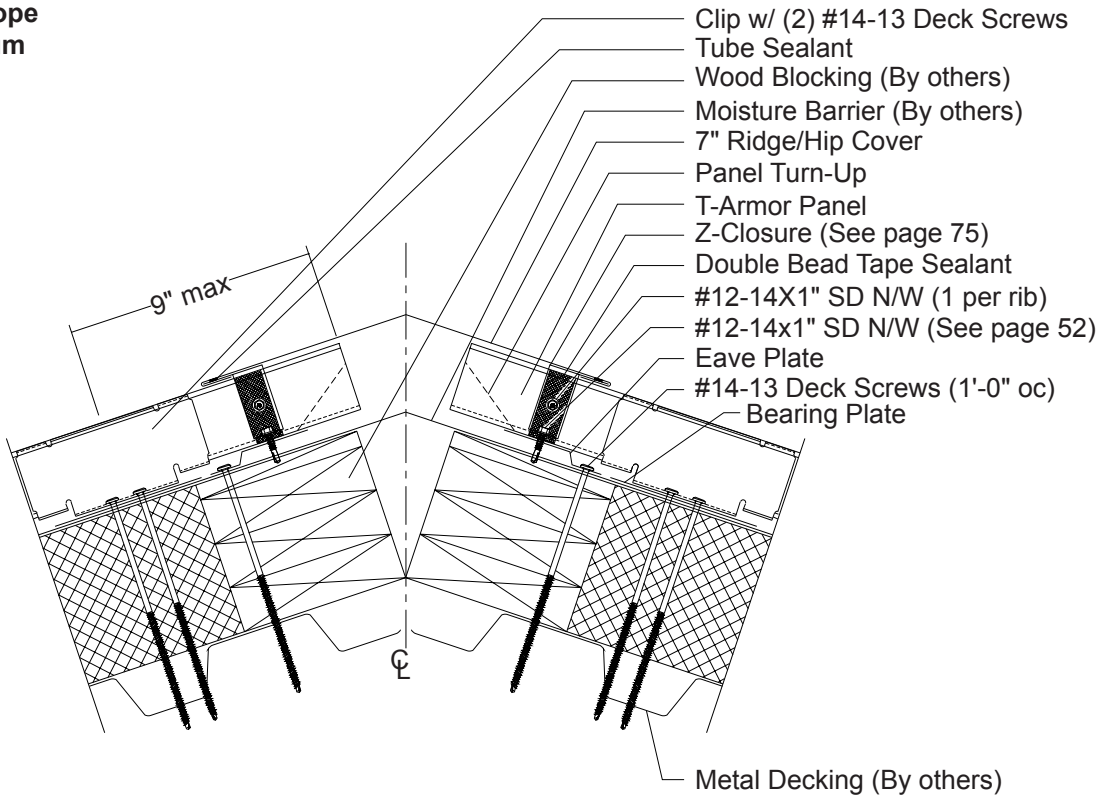

Panel cap not shown for clarity.

Additional #14-13 Deck Screws may be required for areas with large snow loads.

INSTALLATION NOTES

1. Install Eave Plate and fasten through the wood blocking into the metal deck with #14-13 Deck Screws at 1'-0" oc. If more than one Eave Plate is required then butt the ends together.
2. Place panels on to the Eave Plate and apply a row of Double Bead Tape Sealant across panel, up and over all ribs approximately 2" to 3" from panel end.
3. Field-cut Z-Closure to fit between the panel ribs, install Z-Closure over Tape Sealant. Before continuing, make sure Z-Closure placement will accommodate 7" Ridge/Hip Cover.
4. Once closure is set in Tape Sealant, fasten through Z-Closure, Tape Sealant, T-Armor panel and into the Eave Plate with #12-14x1" Self Driller N/W screws (see page 75 for number of fasteners required).
5. Install 7" Ridge/Hip Cover by applying a bead of Tube Sealant to the top of the Z-Closure, setting the flashing in place by hooking onto the Z-Closure.
6. If two or more flashings are required, lap the flashing over the previously installed flashing by a minimum of 2" placing a bead of Tube Sealant between the flashings and secure with Pop Rivets, 2.5" oc.

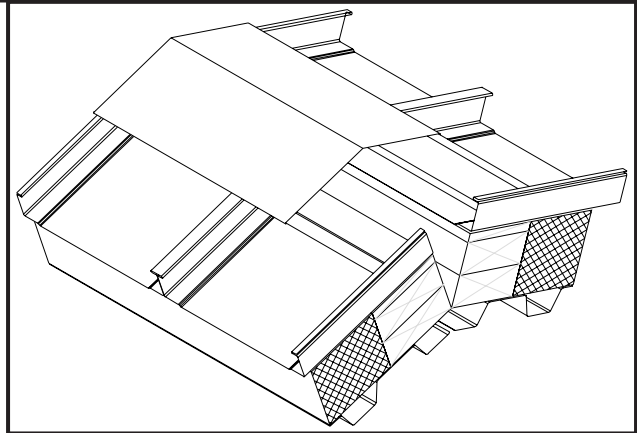

**1/2:12 Slope
Minimum**

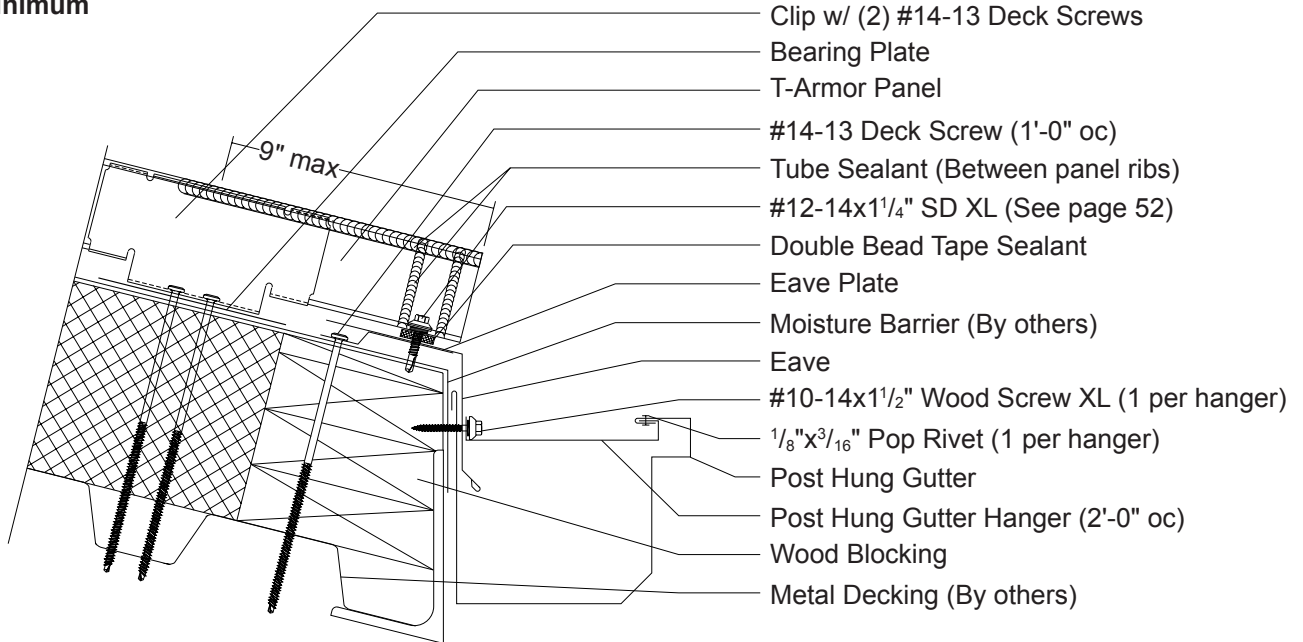

Panel cap not shown for clarity.

Additional #14-13 Deck Screws may be required for areas with large snow loads.

CAUTION

In locations where heavy rainfall or severe ice and snow may occur, Metal Sales standard gutters may not be suitable for use.

INSTALLATION NOTES

All Eave flashings must be installed prior to panel installation.

1. Install new Eave Plate over top of rigid board insulation and fasten through the wood blocking into the metal deck with #14-13 Deck Screws at 1'-0" oc.
2. Install new Eave flashing on top of the Eave Plate.
3. Apply a continuous row of Double Bead Tape Sealant across the top of the Eave flashing.
4. Set panel into place and use #12-14x1 1/4" Self Driller XL screws to fasten into place (see page 52).
5. Apply Tube Sealant up the side and across the top of the panel ribs before installing the next panel.
6. Install the Gutter by sliding it behind the Eave. Install the Post Hung Gutter Hangers at 2'-0" oc, fastening through the Eave into the roof framing.
7. If two or more flashings are required, lap the flashing over the previously installed flashing by a minimum of 2", place two beads of Tube Sealant between the flashings and secure with Pop Rivets, 2.5" oc.

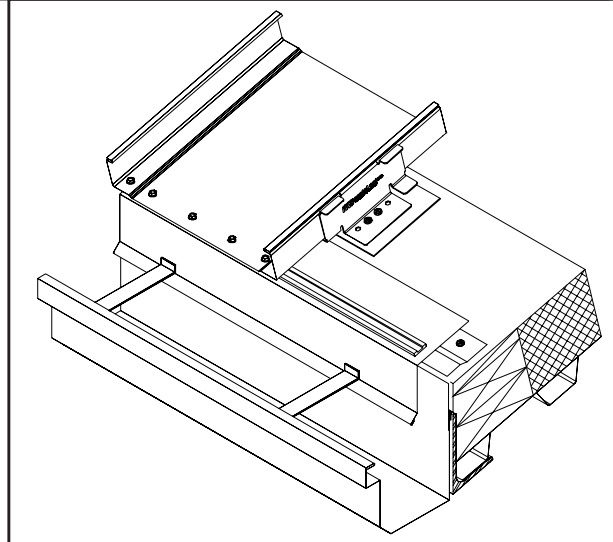

**1/2:12 Slope
Minimum**

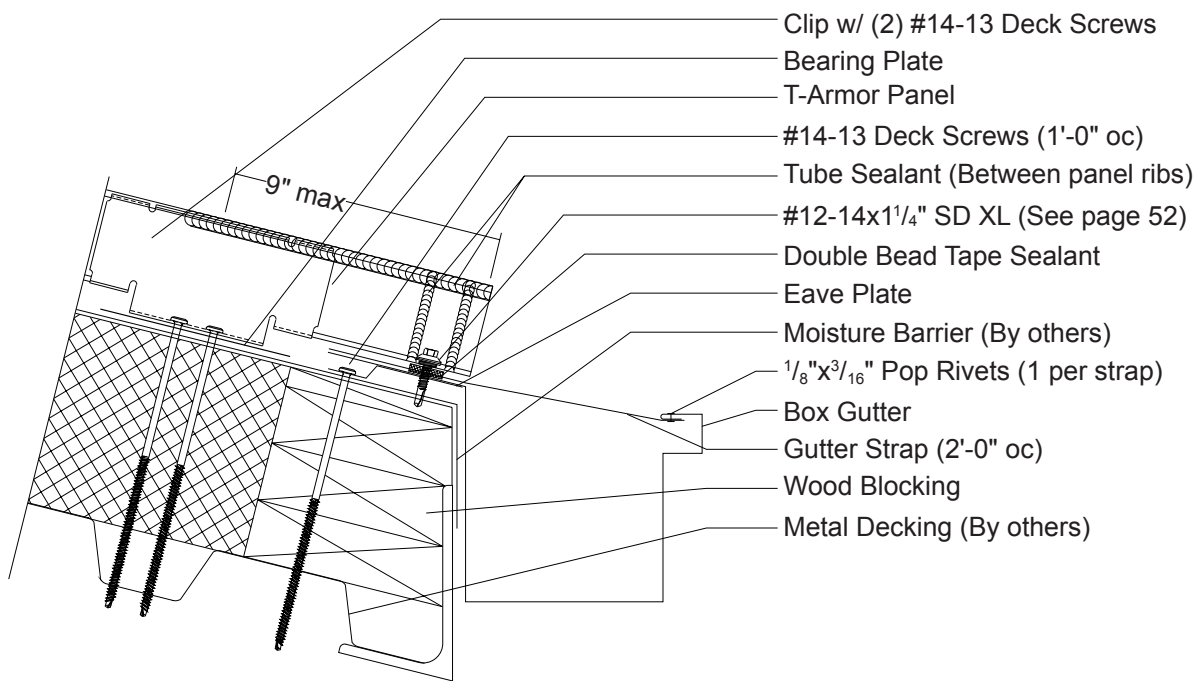

Panel cap not shown for clarity.

Additional #14-13 Deck Screws may be required for areas with large snow loads.

CAUTION

In locations where heavy rainfall or severe ice and snow may occur, Metal Sales standard gutters may not be suitable for use.

INSTALLATION NOTES

All Eave flashings must be installed prior to panel installation.

1. Install new Eave Plate over top of rigid board insulation and fasten through the wood blocking into the metal deck with #14-13 Deck Screws at 1'-0" oc.
2. Install new Box Gutter flashing on top of the Eave Plate.
3. If two or more flashings are required, lap the flashing over the previously installed flashing by a minimum of 2" placing two rows of Tube Sealant between the flashings and secure with Pop Rivets, 2.5" oc.
4. Apply a continuous row of Double Bead Tape Sealant across the top of the Eave flashing.
5. Place Gutter Staps into place at 2'-0" oc and fasten to the front of the Box Gutter with a 1/8"x3/16" Pop Rivet.
5. Set panel into place and use #12-14x1 1/4" Self Driller XL screws to fasten into place (see page 52).
6. Apply Tube Sealant up the side and across the top of the panel ribs before installing the next panel.

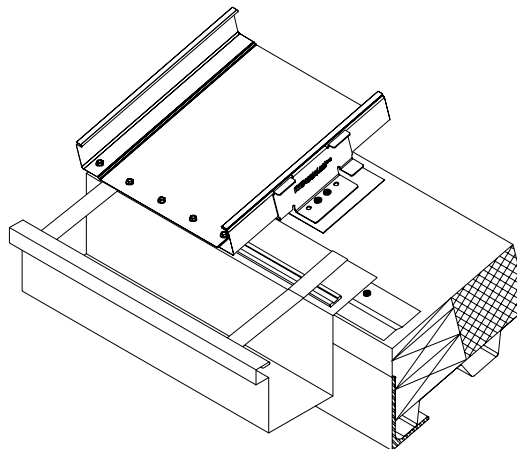

**1/2:12 Slope
Minimum**

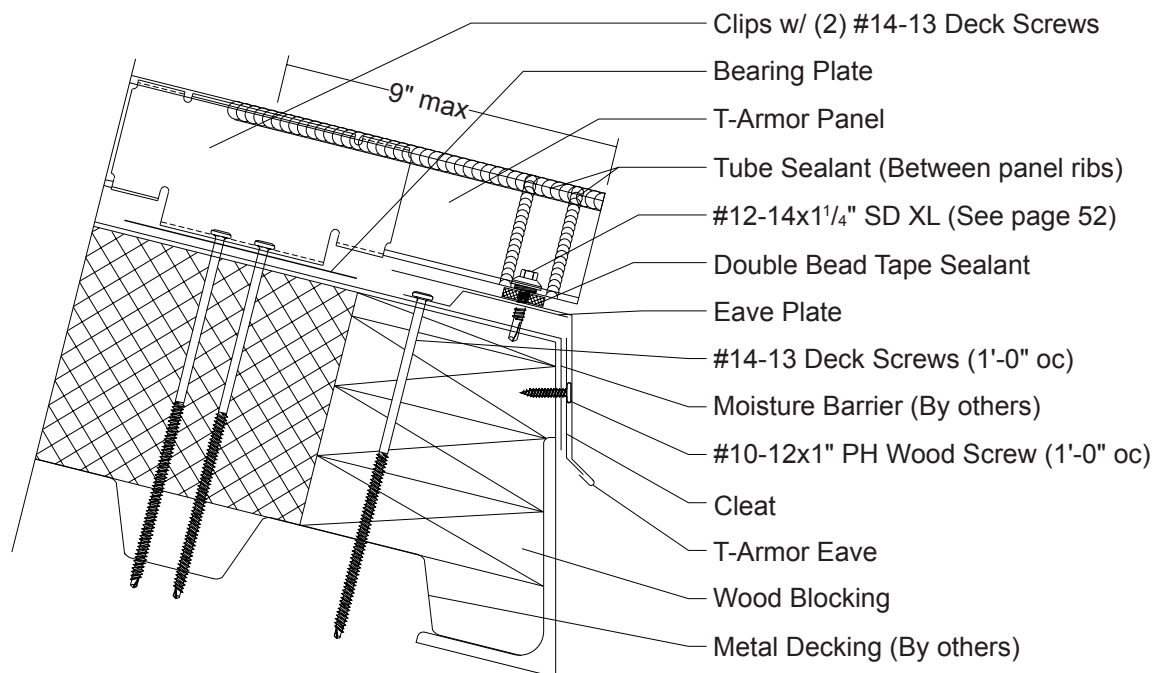

Panel cap not shown for clarity.

Additional #14-13 Deck Screws may be required for areas with large snow loads.

INSTALLATION NOTES

All eave flashings must be installed prior to panel installation.

1. Install Eave Plate over top of rigid board insulation and fasten through the wood blocking into the metal deck with #14-13 Deck Screws 1'-0" oc.
2. Install T-Armor Eave by engaging to Roof Cleat and rotating onto the Eave Plate.
3. If two or more flashings are required, lap the flashing over the previously installed flashing by a minimum of 2" placing two beads of Tube Sealant between the flashings and secure with Pop Rivets, 2.5" oc.
4. Apply a continuous row of Double Bead Tape Sealant across the top of the T-Armor Eave.
5. Set panel into place and use #12-14x1 1/4" Self Driller XL screws to attach (see page 52).
6. Apply Tube Sealant up the side and across the top of the panel ribs before installing the next panel.

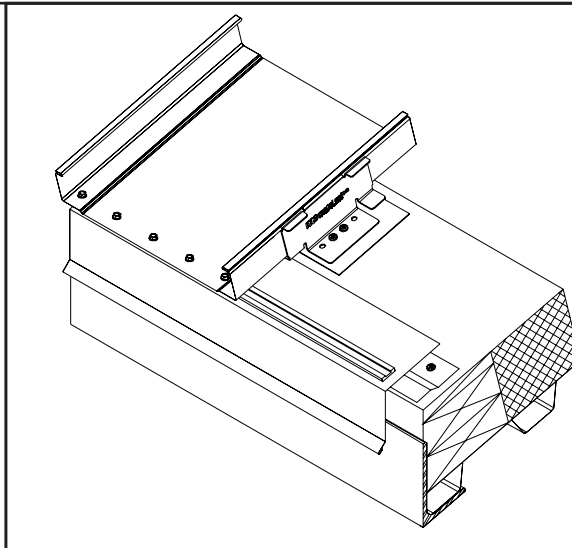

**3:12 Slope
Minimum**

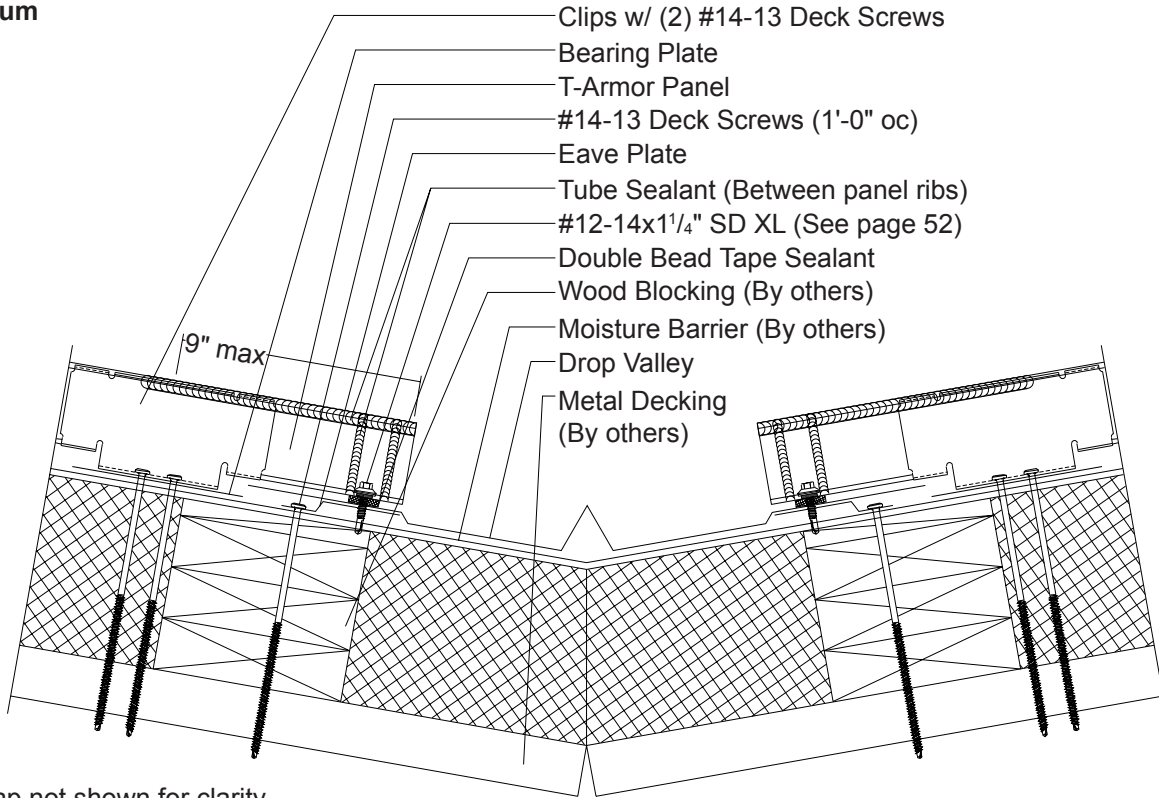

Panel cap not shown for clarity.

Additional #14-13 Deck Screws may be required for areas with large snow loads.

INSTALLATION NOTES

All Eave and Drop Valley flashings must be installed prior to panel installation.

1. Install new Eave Plate over top of rigid board insulation and fasten through the Valley Plate and wood blocking into the metal deck at 1'-0" oc.
2. Install new Drop Valley flashing on top of the Eave Plate.
3. If two or more flashings are required, lap the flashing over the previously installed flashing by a minimum of 6", placing two beads of Tube Sealant between the flashings. Locate beads of Tube Sealant so that it does not press out of the lap. Do not install fasteners through the Drop Valley lap.
4. Apply a continuous row of Double Bead Tape Sealant across the top of each side of the Drop Valley flashing.
5. Set panel into place and use #12-14x1 1/4" Self Driller XL screws to attach (see page 52).
6. Apply Tube Sealant up the side and across the top of the panel ribs before installing the next panel.

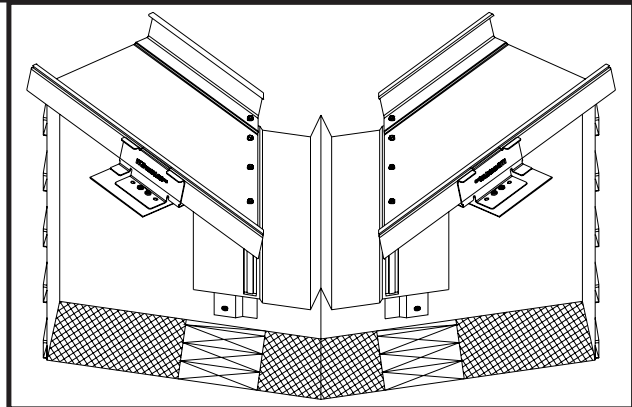

**1/2:12 Slope
Minimum**

With Reglet

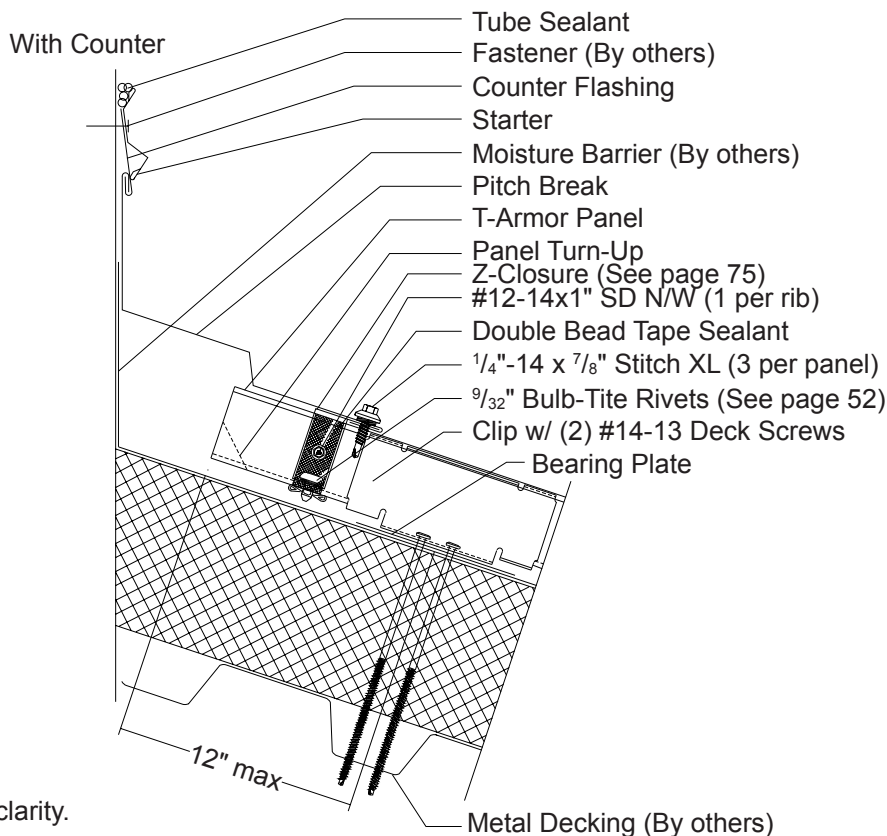
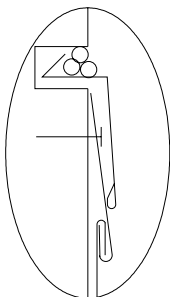

Panel cap not shown for clarity.

This detail can only be used with the low and high clip systems.

INSTALLATION NOTES

1. Once panels have been installed, apply a row of Double Bead Tape Sealant across panel, up and over all ribs approximately 2" to 3" from panel end.
2. Field-cut Z-Closure to fit between the panel ribs, install Z-Closure over Tape Sealant. Before continuing, make sure Z-Closure placement will accommodate Pitch Break.
3. Once closure is set in Tape Sealant, fasten through Z-Closure, Tape Sealant and T-Armor panel with 9/32" Bulb-Tite Rivets and one #12-14x1" Self Driller N/W screw (see page 52 for number of fasteners required).
4. Apply a row of Double Bead Tape Sealant to the top of the Z-Closure.
5. Install Pitch Break by hooking the open hem around the Z-Closure, and fasten into the wall substrate with fasteners at 1'-0" oc maximum.
6. If two or more flashings are required, lap the flashing over the previously installed flashing by a minimum of 2" placing a bead of Tube Sealant between the flashings and secure with Pop Rivets, 2.5" oc.
7. Install Counter Flashing, Reglet or wall panel and fasten to parapet wall with appropriate fastener, 1'-0" oc. Seal to Counter Flashing, Reglet or parapet wall with Tube Sealant.

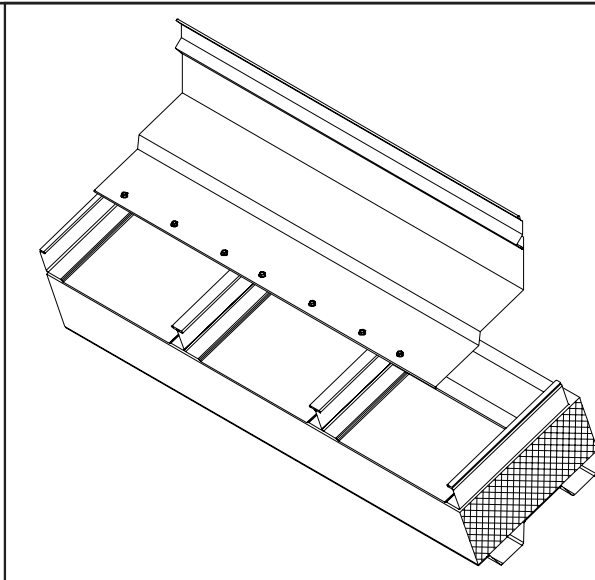

**1/2:12 Slope
Minimum**

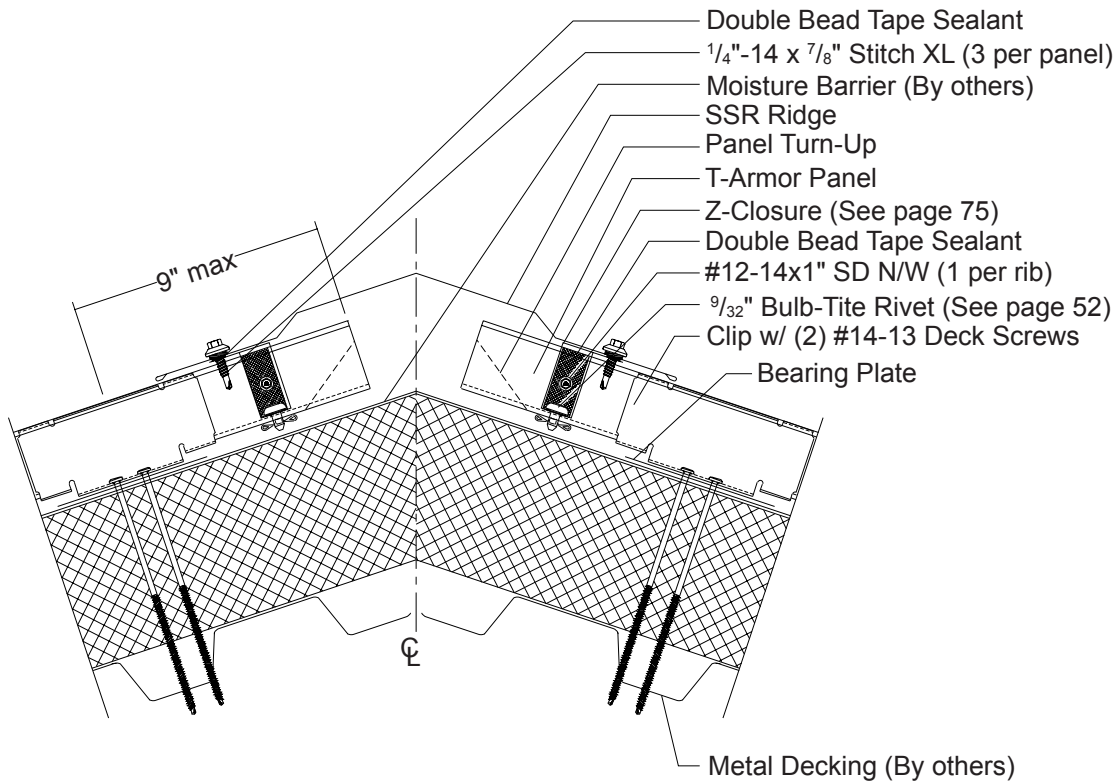

Panel cap not shown for clarity.

This detail can only be used with the low and high clip systems.

INSTALLATION NOTES

1. Once panels have been installed, apply a row of Double Bead Tape Sealant across panel, up and over all ribs approximately 2" to 3" from panel end.
2. Field-cut Z-Closure to fit between the panel ribs, install Z-Closure over Tape Sealant. Before continuing, make sure Z-Closure placement will accommodate SSR Ridge flashing.
3. Once Z-Closure is set in Tape Sealant, fasten through Z-Closure, Tape Sealant and T-Armor panel with $\frac{9}{32}$ " Bulb-Tite Rivets and one #12-14x1" Self Driller N/W screw in the rib (see page 52 for number of fasteners required).
4. Install SSR Ridge flashing by applying Double Bead Tape Sealant to the top of the Z-Closures, locating the SSR Ridge and securing with 3 Pop Rivets per panel.
5. If two or more flashings are required, lap the flashing over the previously installed flashing by a minimum of 2" placing a bead of Tube Sealant between the flashings and secure with Pop Rivets, 2.5" oc.

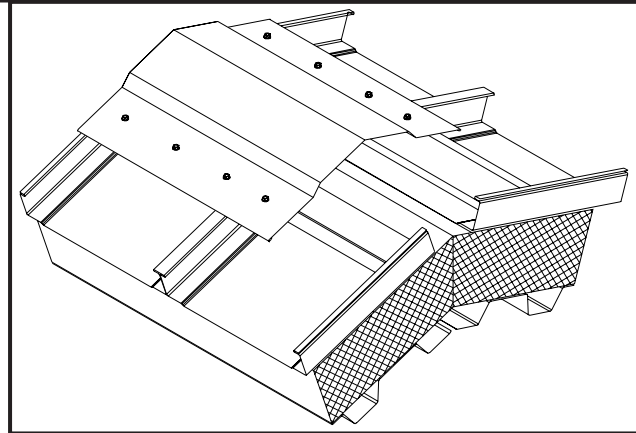

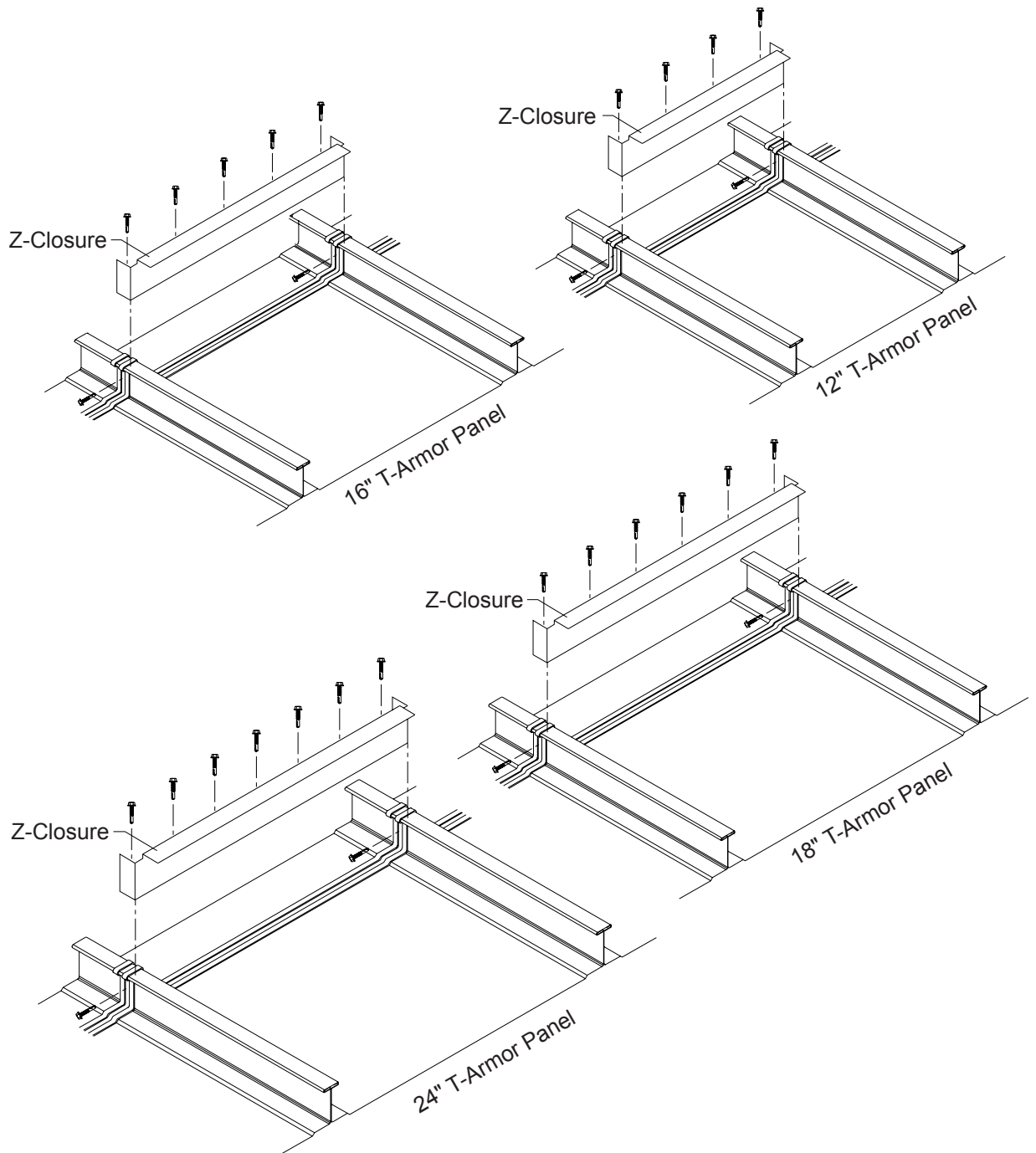

INSTALLATION NOTES

Panel Cap must be installed and hand crimped into place before the Z-Closure can be installed.

1. Place a row of Double Bead Tape Sealant across panel and over each rib approximately 4" to 6" from panel end. Before proceeding, make sure Z-Closure placement will accommodate flashing.
2. Field-cut the Z-Closure 2" longer than the panel width. Snip the top and bottom leg of the Z-Closure and bend both sides back (as shown above). Field-notch Z-Closure end to fit under panel rib and cap.
3. Fasten through the Z-Closure, Tape Sealant, T-Armor panel and substrate with appropriate fasteners.
4. Use a #12-14x1" Self Driller N/W screw to fasten through the side of panel rib, Tape Sealant and Z-Closure. See page 52 for fastener locations.

PANEL HEMMING

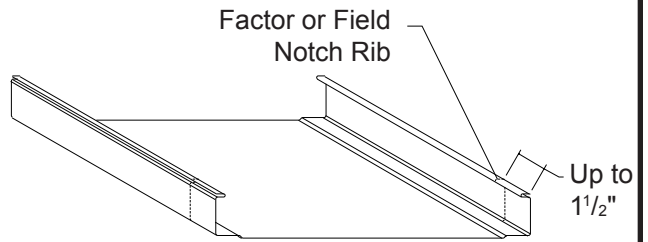
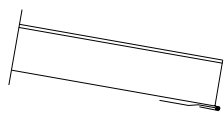
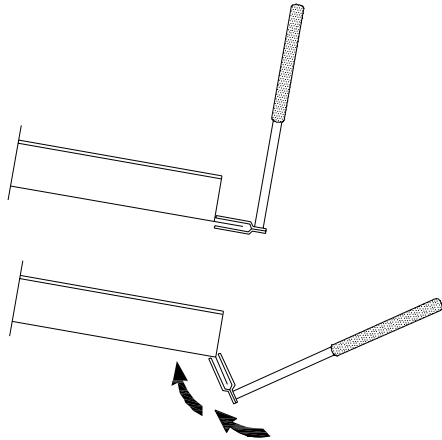
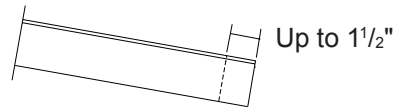

Field-bend flat part of panel to accept Offset Cleat

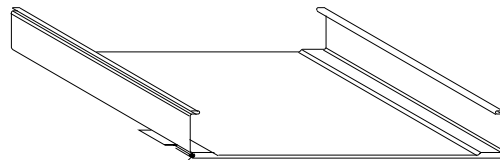
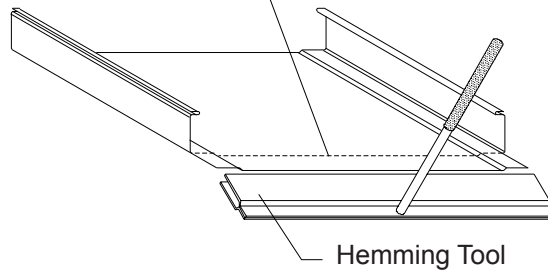

Field-apply Tube Sealant in hem and insert Offset Cleat

PANEL TURN-UP

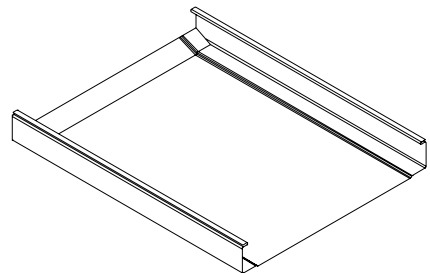
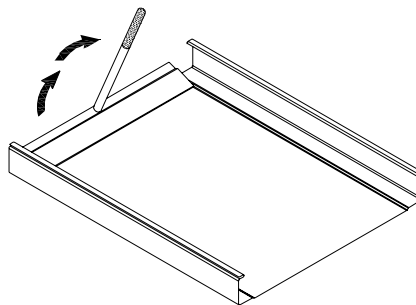
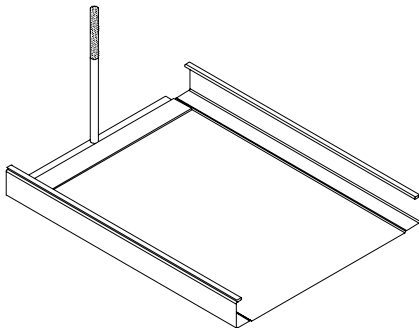

Note: See page 15 to associate panel with correct hemming/turn-up tool.

Z-CLOSURE BEND

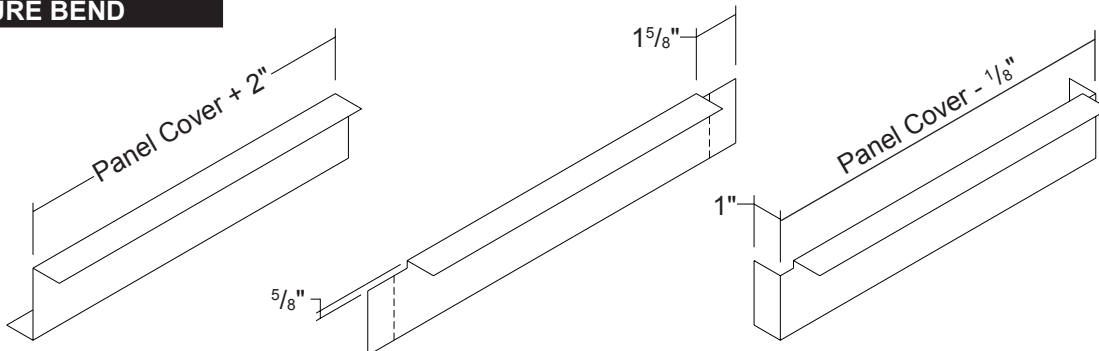

ROOF PENETRATIONS

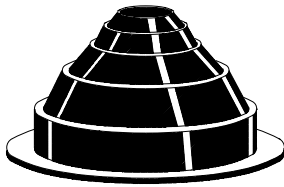

- Mini (1/4" to 1 1/8" O.D. Pipe)
- #2 (1 3/4" to 3" O.D. Pipe)
- #4 (3" to 6" O.D. Pipe)
- #6 (6" to 9" O.D. Pipe)
- #8 (7" to 13" O.D. Pipe)

Temperature Range: -30° to +250°

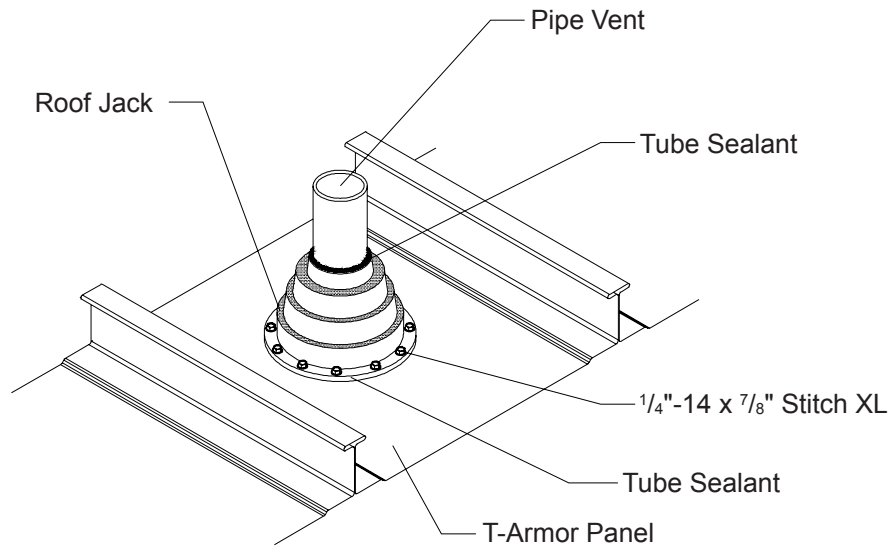

GENERAL NOTES

Size and location of all roof penetrations should be an important consideration. Areas around roof vents or rooftop units may show that corrosive fumes are emitted from a process within the building.

INSTALLATION NOTES

NOTE: The following procedures are for vent pipes 6" or less and not transmitting extremely hot or caustic materials. When installing vent pipes abide by the local plumbing codes.

1. Determine the size and length of the vent pipe to be raised.
2. Take the appropriate measurements for the vent location and mark them on the T-Armor panel. The vent pipe must extend through the flat of the roof panel. If the vent pipe extension cannot be raised directly into the flat of the new roof panel, elbows should be used to offset the pipe. Cut the panel to fit the vent pipe properly.
3. Use a light gauge angle to secure and plumb the vent pipe to the framing system.
4. Flash the vent pipe with a Rubber Roof Jack or similar pipe flashing.
5. Apply Tube Sealant between the panel and the base of the Rubber Roof Jack as well as the top where the boot meets the pipe.
6. Attach the base of the Rubber Roof Jack to the panel using 1/4"-14 x 7/8" Stitch XL fasteners.

FLASHING LAPS

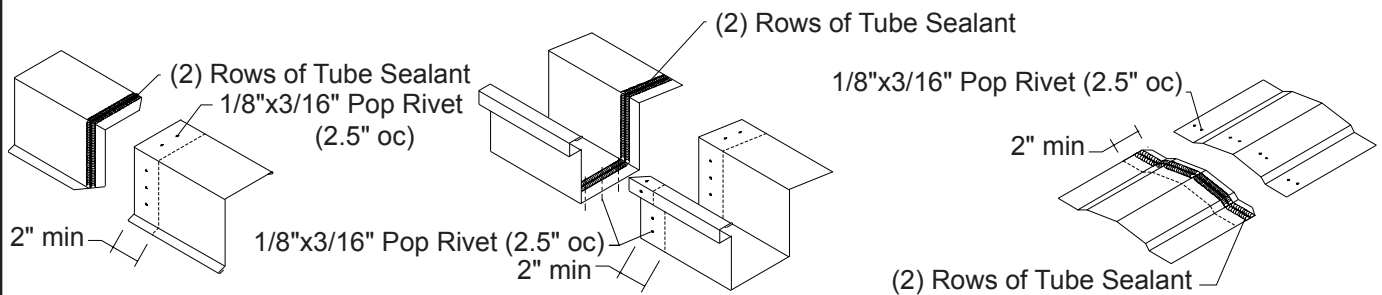

Though factory-applied prepainted finishes are very durable and will last many years, eventually it may be desirable to thoroughly clean or repaint them.

Dirt accumulation may cause apparent discoloration of the paint when it has been exposed in some dirt laden atmospheres for long periods of time. In areas of strong sunlight, slight chalking may cause some change in appearance. A good cleaning will often restore the appearance of these buildings and render repainting unnecessary. An occasional light cleaning will help maintain a good appearance.

In many cases, simply washing the building with plain water using a hose or pressure sprayer will be adequate. In areas where heavy dirt deposits dull the surface, a cloth or soft bristle brush and solution of water and detergent ($\frac{1}{3}$ cup of laundry detergent per gallon of water for example) may be used. This should be followed by an adequate rinse of water. Do not use wire brushes, abrasives or cleaning tools which will damage the coating surface.

Mildew may occur in areas subject to high humidity but is not normally a problem due to the high inherent mildew resistance of the baked finish that is used. However, mildew can grow on dirt and spore deposits in some cases. To remove mildew along with the dirt, the following solution is recommended.

- $\frac{1}{3}$ cup detergent (Tide® or equivalent)
- $\frac{2}{3}$ cup trisodium phosphate (Solex® or equivalent)
- 1 quart of 5% sodium hypochlorite solution (Clorox® or equivalent)
- 3 quarts of water

Strong solvents and abrasive type cleaners should be avoided. Most organic solvents are flammable and toxic, and must be handled accordingly. When using a solvent, consult maintenance professionals and label instructions for proper handling and disposal of washings. If required, a mild solvent such as mineral spirits can be used to remove caulking compounds, oil, grease, tars, wax and similar substances. Use a cloth dampened with mineral spirits and apply only to areas which are contaminated. Follow up the use of this mild solvent with detergent cleaning and rinsing.



**DO NOT USE A
WIRE BRUSH**

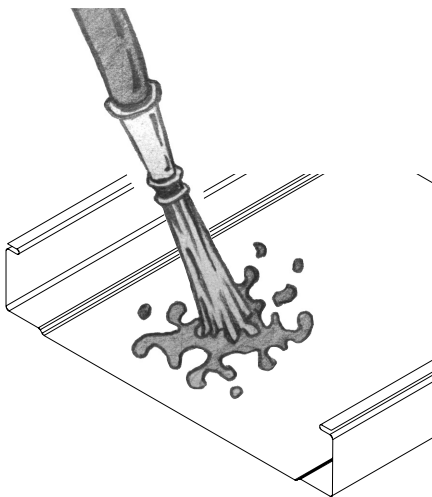

**HOSE OR PRESSURE SPRAY
FOR ADEQUATE CLEANING**



**USE MILD DETERGENT AND WATER
FOR HEAVY DIRT DEPOSITS**

PANEL REPLACEMENT PROCEDURE

Steps:

1) Remove Trims

Any trims that attach to the damaged panel must be removed or the fasteners that attach to the panel and the trim must be removed. Typical trims that must be addressed include: Ridge, Hip, Peak, Eave, Endwall, Sidewall and Roof Penetrations. The end fasteners, including the horizontal fastener, and the Z-Closure at the high end of the panel must be removed.

2) Remove Caps

The caps on each side of the damaged panel must be removed. In addition to renting seaming machines, DI also rents a De-Seaming machine that will remove a seamed-on cap. The caps can be removed manually with a screw driver to open the end of the cap and a pry bar to lift the cap off of the panel. Care must be taken to avoid damaging the panels if the caps are removed manually.

3) Remove Damaged Panel

After removing all attachments to the damaged panel, pull the hem at the top of the panel off of the panel clips and lift one side of the panel out of its place. A pair of locking pliers can be an effective tool for taking hold of the panel hem. If the panel is hemmed at the low end, sliding the panel downslope will allow the panel to be removed. For stiff panels (ex. 12" wide, 20 ga panels), it may be necessary to rip the panel by cutting it in the flat from low end to high end with power shears or nibblers.

Once the damaged panel is removed, check the exposed clips, fasteners, Offset Cleat at eave for damage and replace any damaged components.

4) Install New Panel

Place the hem on one side of the replacement panel on the clips. If the eave-end of the panel is hemmed, slide the panel on to the Offset Cleat before engaging the hem on the other side of the panel. If the panel contains an endlap, then install the lowest panel first, working up slope.

5) Install New Caps

Before installing the new caps on each side of the replaced panels, remove any sealant that remains on the adjacent, non-damaged panels. Install the new caps starting at the low end and working upslope.

6) Install Trims

Before reinstalling the trims, inspect them to see whether they should be replaced due to damage. Sealant that remains on the trims should be removed and replaced. New fasteners should be used, rather than reusing the original fasteners.

Ordering Parts:

Order panels taking into account the additional length that may be needed at eave hem or endlaps.

Order one more cap than the number of panels, of comparable lengths.

Order parts for endlaps, including Stiffening Plates, sealant and fasteners.

Order replacement trims and fasteners.

Rent a Power Seamer, Hand Crimper and Power DeSeamer.

