

U-PANEL

CONDENSED
TECHNICAL
REFERENCE

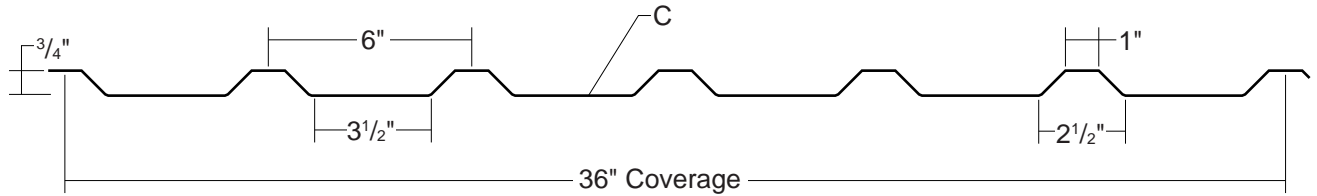

COMMERCIAL
INDUSTRIAL
PANEL

EXPOSED
FASTENED

36"
COVERAGE

WALL
PANEL

OPEN FRAMING OR
SOLID SUBSTRATE

PANEL OVERVIEW

- ▶ Finishes: PVDF (Kynar 500®), MS Colorfast45® and Acrylic Coated Galvalume®
- ▶ Corrosion Protection: AZ55 per ASTM A 792 for unpainted Galvalume®
AZ50 per ASTM A 792 for painted Galvalume®
G90 per ASTM A 653 for Galvanized
- ▶ Gauges: 26 ga and 24 ga standard; 22 ga optional
- ▶ 36" panel coverage, $\frac{3}{4}$ " rib height
- ▶ Panel Length: Minimum: 5'; Maximum: 45' recommended
- ▶ Exposed fastened metal building roof and wall system
- ▶ Trapezoidal rib on 6" centers
- ▶ Wall Panel

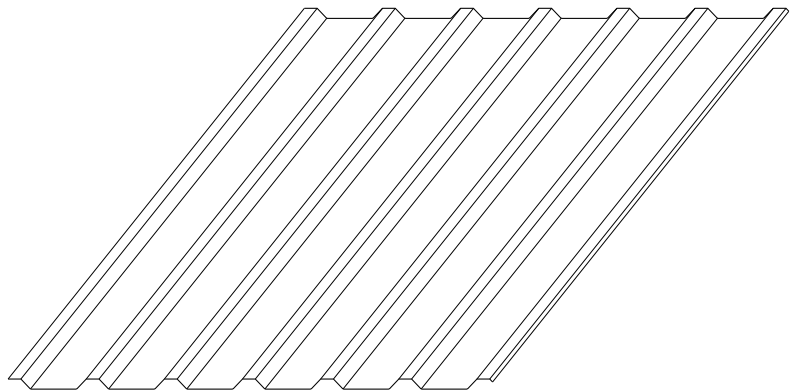

TESTING AND APPROVALS

- ▶ UL 2218 Impact Resistance - Class 4
- ▶ UL 790 Fire Resistance Rating - Class A, per building code
- ▶ UL 263 Fire Resistance Rating - per assembly
- ▶ UL 580 Uplift Resistance - Class 90 Construction: #39

ms metal sales
manufacturing corporation

U-PANEL

CONDENSED TECHNICAL REFERENCE

ATTACHMENT DETAIL

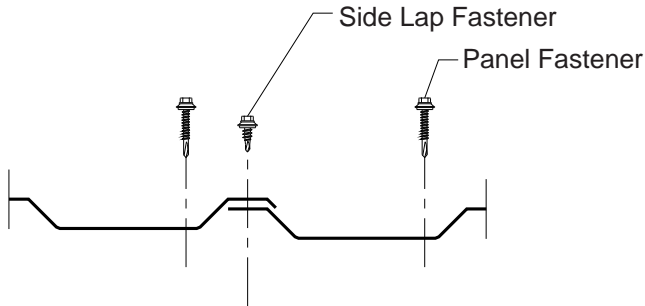

FASTENING PATTERN

Ends and Field of Panel

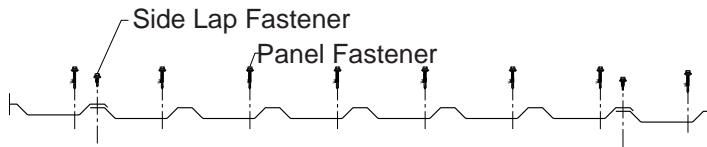

FASTENER INFORMATION

Overdriven fasteners will cause panel distortions.

Fasteners should extend 1/2" or more past the inside face of the support material.

Thick panels (ex. 18 ga) or supports (ex. 1/2" steel) may require predrilling of holes for screws.

Panel Fastener:

Attaching to Wood:

#10-14 XL Wood Screw

Attaching to Steel:

#12-14 XL Self Drilling Screw

Side Lap Fastener:

1/4"-14 x 7/8" XL Stitch Screw

Trim Fastener:

1/4"-14 x 7/8" XL Stitch Screw

SECTION PROPERTIES

ALLOWABLE UNIFORM LIVE LOADS, psf For various fastener spacings

Ga	Width in	Yield ksi	Weight psf	Top in Compression		Bottom in Compression		Inward Load						Outward Load					
				I _{xx} in ⁴ /ft	S _{xx} in ³ /ft	I _{xx} in ⁴ /ft	S _{xx} in ³ /ft	2'	3'	4'	5'	6'	7'	2'	3'	4'	5'	6'	7'
26	36	80	0.81	0.0187	0.0349	0.0127	0.0369	245	112	58	29	17	11	234	106	58	29	17	11
24	36	50	1.05	0.0270	0.0517	0.0183	0.0461	259	118	67	40	23	14	288	131	75	40	23	14
22	36	50	1.38	0.0380	0.0736	0.0270	0.0673	375	171	97	53	31	19	406	186	103	53	31	19

- Theoretical section properties have been calculated per AISI 2007 'North American Specification for the Design of Cold-Formed Steel Structural Members'. I_{xx} and S_{xx} are effective section properties for deflection and bending.
- Allowable load is calculated in accordance with AISI 2007 specifications considering bending, shear, combined bending and shear and deflection. Allowable load considers the 3 or more equal spans condition. Allowable load does not address web crippling, fasteners, support material or load testing. Panel weight is not considered.
- Deflection consideration is limited by a maximum deflection ratio of L/180 of span.
- Allowable loads do not include a 1/3 stress increase for wind.

metal sales
manufacturing corporation



Anchorage, AK 866.640.7663
Bay City, MI 888.777.7640
Deer Lake, PA 800.544.2577
Denver, CO 800.289.7663
Detroit Lakes, MN 888.594.1394
Fontana, CA 800.782.7953
Fort Smith, AR 877.452.3915

Independence, MO 800.747.0012
Jacksonville, FL 800.394.4419
Jefferson, OH 800.321.5833
Mocksville, NC 800.228.6119
Nashville, TN 800.251.8508
Rock Island, IL 800.747.1206
Rogers, MN 800.328.9316

Seattle, WA 800.431.3470
Sellersburg, IN 800.999.7777
Sioux Falls, SD 888.902.8320
Spokane, WA 800.572.6565
Temple, TX 800.543.4415
Woodland, CA 800.759.6019

www.metalsales.us.com