

# *Stile*

---

## *Installation Guide*

**metal sales**  
manufacturing corporation



THE APPLICATION AND DETAIL DRAWINGS IN THIS MANUAL ARE STRICTLY FOR ILLUSTRATION PURPOSES AND MAY NOT BE APPLICABLE TO ALL BUILDING DESIGNS OR PRODUCT INSTALLATIONS. ALL PROJECTS SHOULD CONFORM TO APPLICABLE BUILDING CODES FOR THAT PARTICULAR AREA. IT IS RECOMMENDED TO FOLLOW ALL BUILDING REGULATIONS AND STANDARD INDUSTRY PRACTICES.

METAL SALES MANUFACTURING CORPORATION IS NOT RESPONSIBLE FOR THE PERFORMANCE OF THIS ROOF SYSTEM IF IT IS NOT INSTALLED IN ACCORDANCE WITH THE SUGGESTED INSTRUCTIONS REFERENCED IN THIS MANUAL. IF THERE IS A CONFLICT BETWEEN THIS MANUAL AND THE ACTUAL ERECTION DRAWINGS, THE ERECTION DRAWINGS ARE TO TAKE PRECEDENCE.

PRIOR TO ORDERING AND INSTALLING MATERIALS, ALL DIMENSIONS SHOULD BE VERIFIED BY FIELD MEASUREMENTS.

METAL SALES RESERVES THE RIGHT TO MODIFY, WITHOUT NOTICE, ANY DETAILS, RECOMMENDATIONS OR SUGGESTIONS. ANY QUESTIONS YOU MAY HAVE REGARDING PROPER INSTALLATION OF THE STILE ROOFING SYSTEM SHOULD BE DIRECTED TO METAL SALES.

CONSULT METAL SALES FOR ANY ADDITIONAL INFORMATION NOT OUTLINED IN THIS MANUAL.

THIS MANUAL IS DESIGNED TO BE UTILIZED AS A GUIDE WHEN INSTALLING THE STILE ROOFING SYSTEM. IT IS THE RESPONSIBILITY OF THE ERECTOR TO ENSURE THE SAFE INSTALLATION OF THIS PRODUCT SYSTEM.

## SAFETY

### **STUDY APPLICABLE OSHA AND OTHER SAFETY REQUIREMENTS BEFORE FOLLOWING THESE INSTRUCTIONS.**

The installation of metal roof systems is a dangerous procedure and should be supervised by trained knowledgeable erectors. **USE EXTREME CARE WHILE INSTALLING ROOF PANELS.** It is not possible for Metal Sales to be aware of all the possible job site situations that could cause an unsafe condition to exist. The erector of the roof system is responsible for reading these instructions and determining the safest way to install the roof system.

These instructions are provided only as a guide to show a knowledgeable, trained erector the correct parts placement one to another. If following any of the installation steps would endanger a worker, the erector should stop work and decide upon a corrective action.

Provide required safety railings, netting or safety lines for crew members working on the roof.

Do not use the roof panels as a walking platform. The roof panels will not withstand the weight of a person standing at the edge of the panel.

Do not stand on the roof panels at the ends until the panels have been attached.

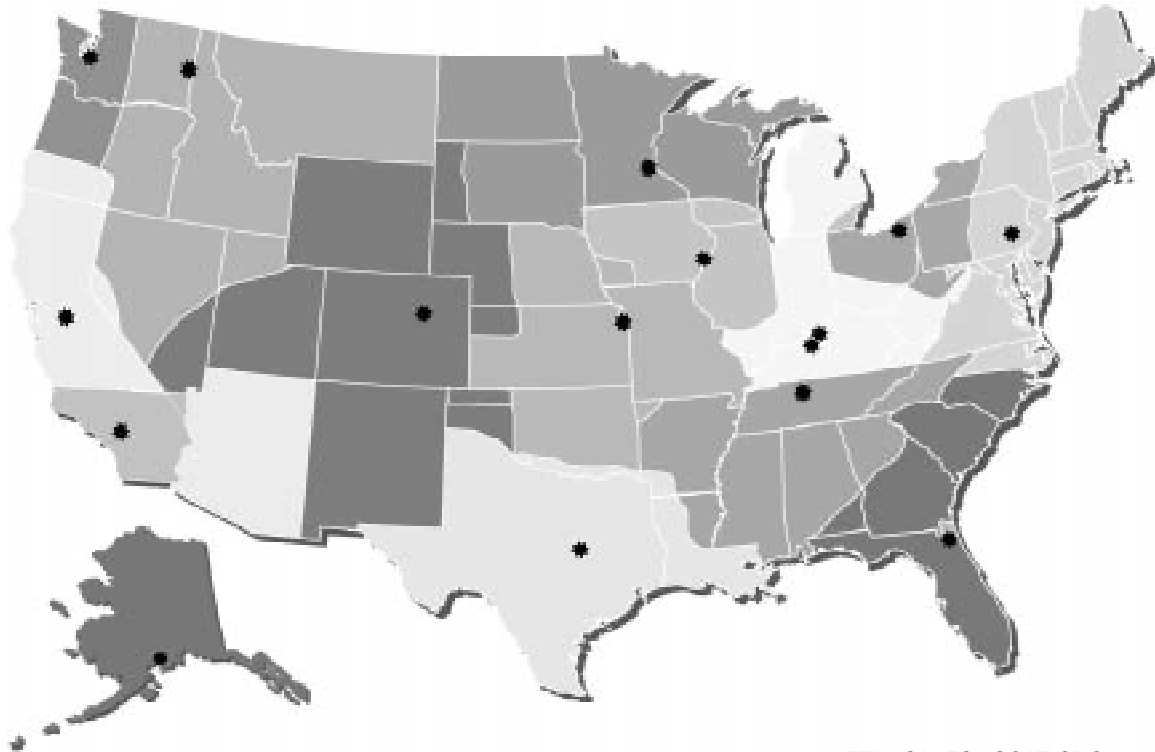
**\*METAL SALES LOCATIONS**

Note: Shaded areas represent regions served by each location.  
Arizona is served by Fontana and Longmont branches.

**CORPORATE OFFICE  
SELLERSBURG, INDIANA**

Metal Sales offers a complete line of metal roof, wall, and fascia panel systems for the commercial, architectural, industrial, residential, and agricultural markets. Metal Sales offers over 30 profiles with a wide selection of widths, colors, and gauges - new construction or retrofit.

**METAL SALES LOCATIONS****DENVER BRANCH**

7990 E. I-25 Frontage Rd  
Longmont, CO 80504  
(303) 702-5440  
(800) 289-7663  
(800) 289-1617 /FAX

**JACKSONVILLE BRANCH**

7110 Stuart Avenue  
Jacksonville, FL 32254  
(904) 783-3660  
(800) 394-4419  
(904) 783-9175 /FAX

**JEFFERSON BRANCH**

352 East Erie Street  
Jefferson, OH 44047  
(440) 576-9070  
(800) 321-5833  
(440) 576-9242 /FAX  
(800) 233-5719 /FAX

**INDEPENDENCE BRANCH**

1306 S. Powell Road  
Independence, MO 64057  
(816) 796-0900  
(800) 747-0012  
(816) 796-0906 /FAX

**WOODLAND BRANCH**

1326 Paddock Place  
Woodland, CA 95776  
(530) 668-5690  
(800) 759-6019  
(530) 668-0901 /FAX

**CLARKSVILLE BRANCH**

7800 State Road 60  
Sellersburg, IN 47172  
(812) 246-1866  
(800) 999-7777  
(812) 246-0893 /FAX  
(800) 477-9318 /FAX

**MINNEAPOLIS BRANCH**

22651 Industrial Blvd.  
Rogers, MN 55374  
(763) 428-8080  
(800) 328-9316  
(763) 428-8525 /FAX  
(800) 938-9119 /FAX

**NASHVILLE BRANCH**

4314 Hurricane Creek Blvd.  
Antioch, TN 37013  
(615) 641-7100  
(800) 251-8508  
(615) 641-7118 /FAX

**SPOKANE BRANCH**

East 2727 Trent Avenue  
Spokane, WA 99202  
(509) 536-6000  
(800) 572-6565  
(509) 534-4427 /FAX

**SEATTLE BRANCH**

20213 84th Avenue, South  
Kent, WA 98032  
(253) 872-5750  
(800) 431-3470 (outside WA)  
(800) 742-7900 (inside WA)  
(253) 872-2008 /FAX

**ROCK ISLAND BRANCH**

8111 West 29th Street  
Rock Island, IL 61201  
(309) 787-1200  
(800) 747-1206  
(309) 787-1833 /FAX

**DEER LAKE BRANCH**

29 Pinedale Industrial Rd  
Orwigsburg, PA 17961  
(570) 366-2020  
(800) 544-2577  
(570) 366-1648 /FAX  
(800) 544-2574 /FAX

**TEMPLE BRANCH**

3838 North General Bruce Dr.  
Temple, TX 76501  
(254) 791-6650  
(800) 543-4415  
(254) 791-6655 /FAX  
(800) 543-4473 /FAX

**FONTANA BRANCH**

14213 Whittram Avenue  
Fontana, CA 92335  
(909) 829-8618  
(800) 782-7953  
(909) 829-9083 /FAX

**ANCHORAGE BRANCH**

4637 Old Seward Hwy.  
Anchorage, AK 99503  
(907) 646-7663  
(907) 646-7664 /FAX

**TECHNICAL SUPPORT****TECHNICAL SERVICES**

7800 State Road 60  
Sellersburg, IN 47172  
(812) 246-0819 (800) 406-7387  
(812) 246-0829 /FAX (800) 944-6884 /FAX  
pserv@aye.net

	<b>PAGE NO.</b>
<b>Panel Overview</b>	
Slope .....	6
Substructures .....	6
Coverage .....	6
Length .....	6
Applications .....	6
Panel Fastening System .....	6
Fasteners .....	6
Materials .....	6
Finishes .....	6
Stile Isometric Panel Profiles .....	6
<b>Flashing Overview</b> .....	7
<b>Flashing and Accessory Profiles</b> .....	8-10
<b>Fastener Selection Guide</b> .....	11
<b>Design / Installation Considerations</b>	
General .....	12
Condition of Substructure .....	12
Ventilation .....	13
Flashing Angle Specifier Chart .....	13
Roof Slope Factor .....	14
<b>Packaging</b> .....	15
<b>Handling Material</b>	
Receiving Material .....	16
General Handling .....	16
Mechanical Handling .....	16
Manual Handling .....	17
<b>Storage</b>	
General .....	18
Foot Traffic .....	18
<b>Field Cutting and Touch-up</b>	
Field Cutting .....	19
Touch-up Paint .....	19
<b>Installation Techniques</b>	
Installation of Eave or Gutter .....	20
Installation of Rake Starter .....	21
Installation of Stile C-Closure .....	22
Installation of Valley .....	23
Installation of Panels .....	24-28
Installation of Formed Rake .....	29
Installation of Formed Ridge .....	30-31
Installation of Chimney .....	32
Installation of Rubber Roof Jack .....	33
Installation of Stile Roof Vent .....	34

	<b>PAGE NO.</b>
<b>Condition Detail Explanation</b> .....	35
Formed Ridge/Hip Detail .....	36
Ridge/Hip Detail .....	37
Formed Rake Detail .....	38
Rake Detail .....	39
Eave Detail .....	40
Extended Eave Detail .....	41
Gutter Detail .....	42
Rake Parapet Counter Detail .....	43
Rake Parapet Siding Detail .....	44
High Side Counter Detail .....	45
High Side Reglet Detail .....	46
Valley with Cover Detail .....	47
High Side Parapet Detail .....	48
Slope Change Detail .....	49
Stile Roof Vent Detail .....	50
<b>Care and Maintenance</b> .....	51

# STILE PANEL OVERVIEW

## SLOPE

The minimum recommended slope for any Stile roofing panel is 3:12.

## SUBSTRUCTURE

The recommended substrate is  $\frac{5}{8}$ " plywood with a #30 felt moisture barrier. To avoid panel distortion, use a properly aligned and uniform substructure.

If your application is over a substrate other than  $\frac{5}{8}$ " plywood, please contact the Metal Sales location servicing you (refer to page 2).

## COVERAGE

Each panel has a coverage of 39.4" (1 meter).

## LENGTH

Minimum factory cut length is 3'-0". Maximum panel length is 20'-0". Lengths between 3'-0" and 20'-0" will be cut at 1'-0" increments.

## APPLICATION

Architectural panel.

## FASTENING SYSTEM

Direct Fasten (exposed).

## FASTENERS

The Fastener Selection Guide (see page 11) should be consulted for choosing proper fasteners for specific applications. Quantity and type of fastener must meet necessary loading and code requirements.

## MATERIALS

Stile panels are available in 26 Gauge Galvanized (G-90) coating.

## FINISHES

Stile panels are available in limited Fluorocarbon (PVF2)\* finishes. See Stile brochure for color selection.

\*Meets both Kynar 500 and Hylar 5000 specifications.

## PANEL ISOMETRIC

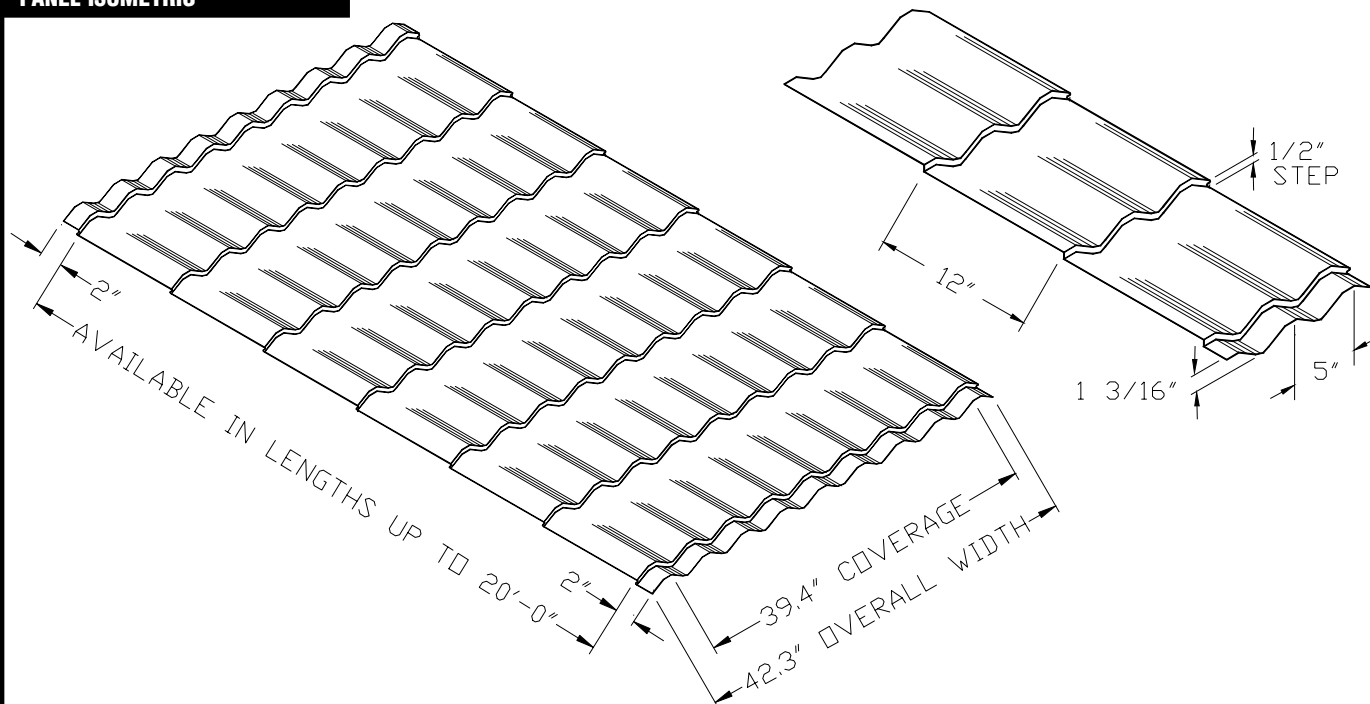

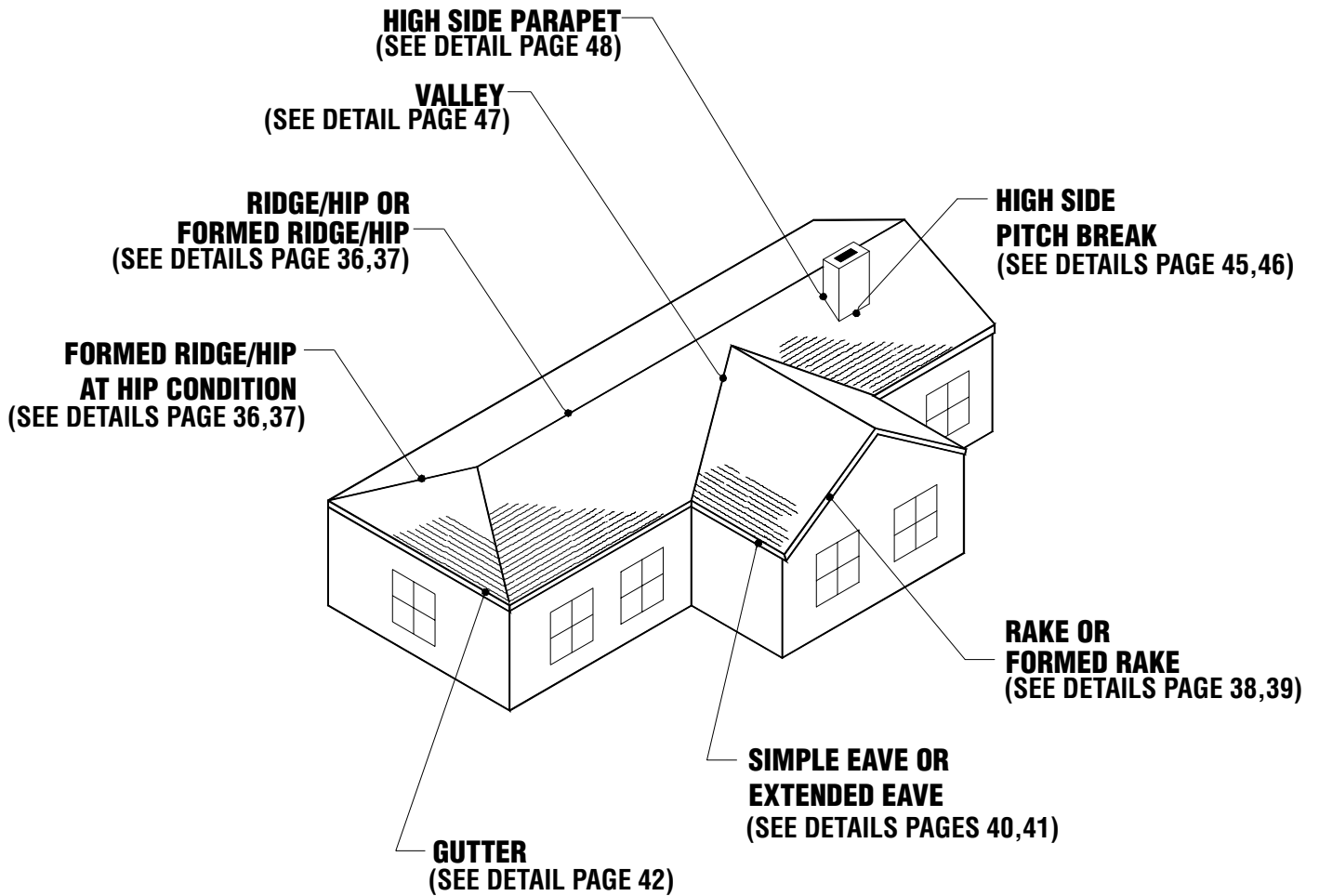

The above building represents the most common conditions of a residential metal roof. For information on installation of flashings refer to details on pages 36-50.



**RAKE STARTER**

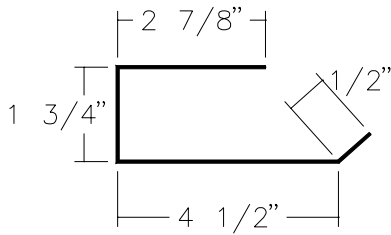

**LENGTH 10'-2"**  
**26 GA. GALVALUME**

**STILE C-CLOSURE**

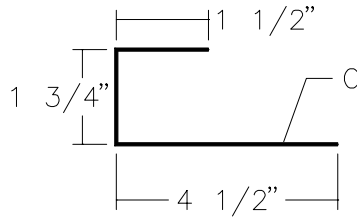

**LENGTH 10'-2"**  
**26 GA. PAINTED**

**STILE STARTER**

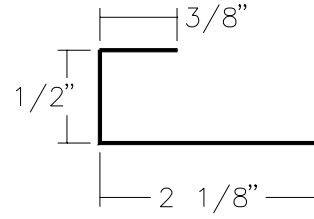

**LENGTH 10'-2"**  
**26 GA.**

**RIDGE/HIP COVER**

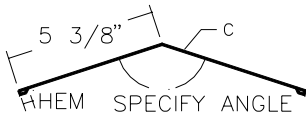

**LENGTH 10'-2"**  
**26 GA. PAINTED**

**FORMED RIDGE**

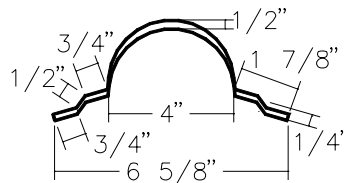

**LENGTH 3'-6"**  
**26 GA. PAINTED**

**PITCH BREAK**

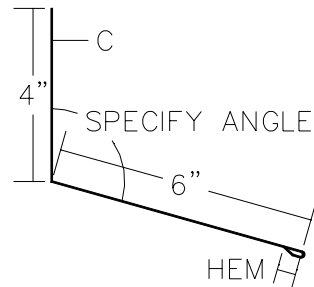

**LENGTH 10'-2"**  
**26 GA. PAINTED**

**REGLET FLASHING**

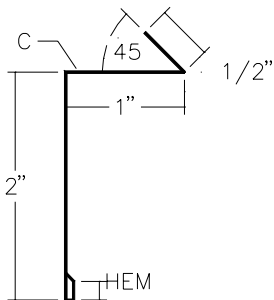

**LENGTH 10'-2"**  
**26 GA. PAINTED**

**COUNTER FLASHING**

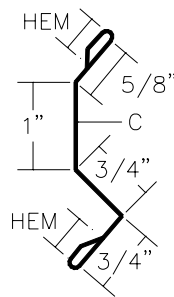

**LENGTH 10'-2"**  
**26 GA. PAINTED**

**FORMED RAKE**

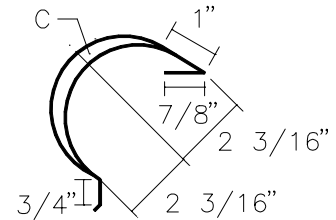

**LENGTH 3'-6"**  
**26 GA. PAINTED**

**RAKE**

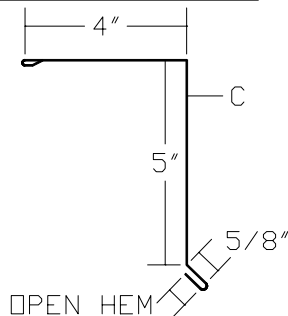

**LENGTH 10'-2"**  
**26 GA. PAINTED**

**CLEAT**

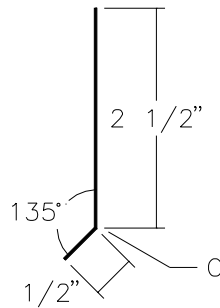

**LENGTH 10'-2"**  
**26 GA. PAINTED**

**VALLEY COVER**

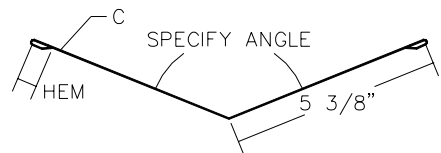

**LENGTH 10'-2"**  
**26 GA. PAINTED**

# STILE FLASHING PROFILES (CONT)

## VALLEY

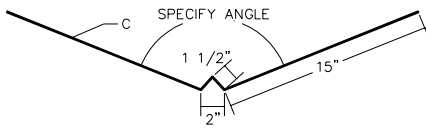

**LENGTH 10'-2"**  
**26 GA. PAINTED**

## EXTENDED EAVE

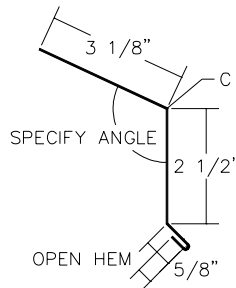

**LENGTH 10'-2"**  
**26 GA. PAINTED**

## EAVE

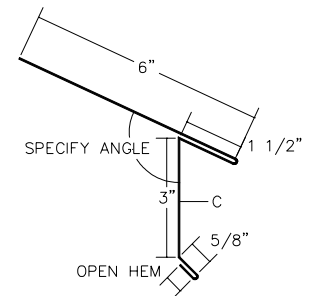

**LENGTH 10'-2"**  
**26 GA. PAINTED**

## BOX GUTTER

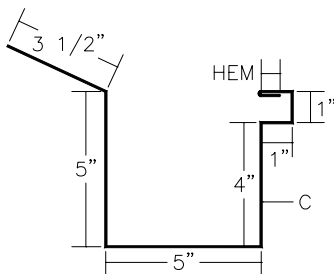

**LENGTH 10'-2"**  
**26 GA. PAINTED**

## BOX GUTTER END

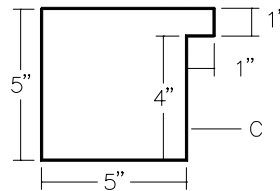

**26 GA. PAINTED**

## UNIVERSAL GUTTER/ DOWNSPOUT STRAP

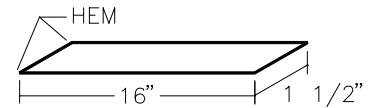

**LENGTH 1'-4"**  
**26 GA. PAINTED**

## DOWNSPOUT

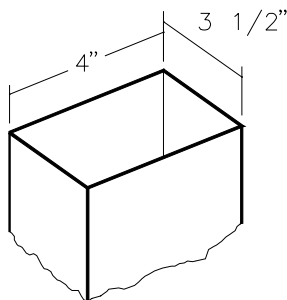

**LENGTH 10'-2"**  
**26 GA. PAINTED**

## 95° ELBOW

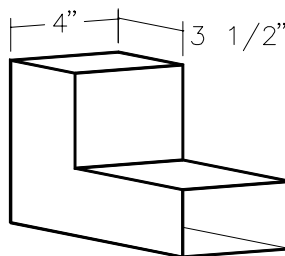

**26 GA. PAINTED**

## DOWNSPOUT BRACKET

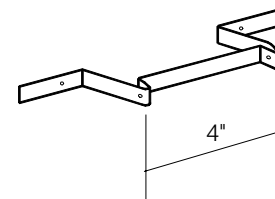

**26 GA. PAINTED**

## JUNCTION SHEET

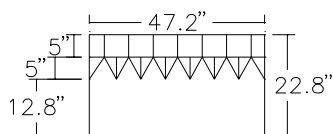

**LENGTH 1'-11"**  
**26 GA. PAINTED**

## STILE CLOSURE

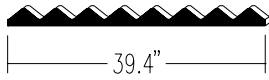

OUTSIDE/ INSIDE CLOSURE

**SYNTHETIC RUBBER**

## STILE FORMED RIDGE CLOSURE



**SYNTHETIC RUBBER**

## UNIVERSAL CLOSURE

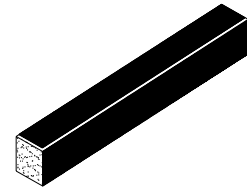

**POLYETHYLENE FOAM**

## RUBBER ROOF JACK

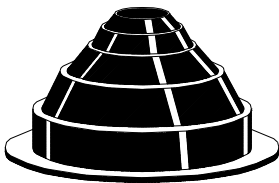

- #2 (1 1/4" TO 3" O.D. PIPE)
- #3 (3" TO 6" O.D. PIPE)
- #6 (6" TO 9" O.D. PIPE)
- #8 (7" TO 13" O.D. PIPE)

## TUBE SEALANT

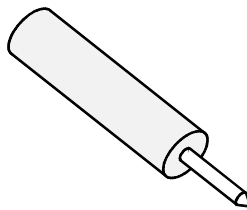

**10.3 oz. CARTRIDGE  
URETHANE - GRAY**

## TAPE SEALER

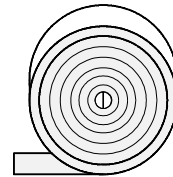

**3/8" X 3/32" X 50'  
BUTYL - GRAY**

## STILE ROOF VENT

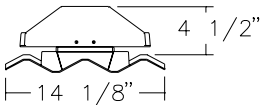
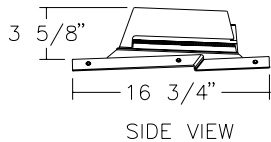

## TOUCH-UP PAINT



**AVAILABLE IN PINTS**

# STILE FASTENER SELECTION GUIDE

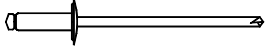
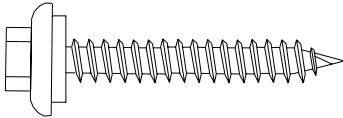
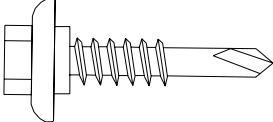
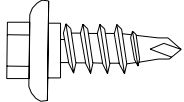
POP RIVET	SIZE	MATERIAL	FINISH	APPLICATION
	1/8" x 3/16"	Stainless Steel	Painted	Attaching Flashings to Panels or Flashings
WOODSCREW XL	SIZE	TYPE	FINISH	APPLICATION
	1/4-14 x 1"	ABMP	XL-Painted	Attaching Panels or Flashings to wood roof deck on Exposed
	1/4-14 x 1 1/2"	ABMP	XL-Painted	
SELF DRILLER XL	SIZE	TYPE	FINISH	APPLICATION
	12-14 x 1 1/4"	Driller	XL-Painted	Attaching Panels or Flashings to metal decking
STITCH SCREW XL	SIZE	TYPE	FINISH	APPLICATION
	1/4-14 x 7/8"	Stitch	XL-Painted	Attaching Flashings to Panels or Flashing

## EXPOSED FASTENER INSTALLATION

**RECOMMENDED TOOL TYPE** - Use depth locating nose or adjustable clutch on screw gun to prevent overdrilling and strip out. **DO NOT USE IMPACT TOOLS OR RUNNERS.**

**SEATING THE WASHER** - Apply sufficient torque to seat the washer - do not overdrive the fastener.

**TO PREVENT WOBBLING** - Make sure fastener head is completely engaged in the socket. If the head does not go all the way in the socket - tap the magnet deeper into the socket to allow full head engagement. Metal chips will build up from drilling and should be removed from time to time.

**PROTECT DRILL POINT** - Push only hard enough on the screw gun to engage clutch. This prevents excess friction and burn out of the drill point. Correct pressure will allow screw to drill and tap without binding.

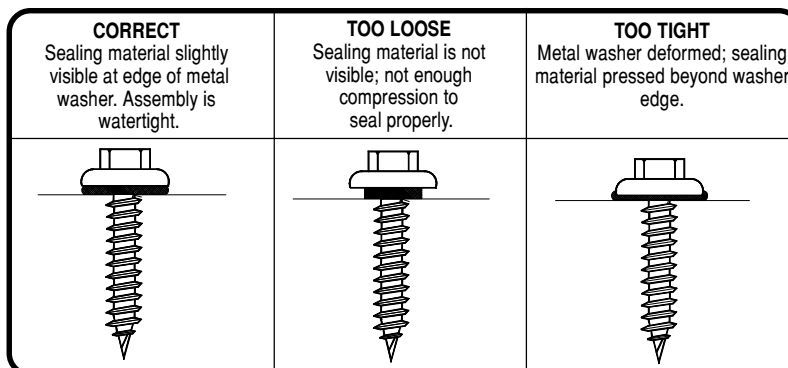

## GENERAL

Metal Sales' Stile panel is recommended to be installed directly over a wood substrate (minimum  $\frac{5}{8}$ " with 30# felt moisture barrier.

Always check with local building codes prior to all installations for any additional requirements that may be specific to your area.

## CONDITION OF SUBSTRUCTURE

The roof should be inspected for any trapped moisture or structural damage such as warped or loose roof decking. These areas should be repaired prior to installing new metal panels.

Prior to installation make sure there are no nails or fasteners protruding from the wood substrate which could damage the panels and impede the installation process. Special attention must be given to Valleys, Ridge, Rake and Eave areas when roofing with Stile panels.

When installed, panel distortion may occur if not applied over properly aligned and uniform substructure.

Whether installing over new or existing roof, the installer should check the roof deck for squareness before installing Stile panels. Several methods can be used to verify squareness of the structure for proper installation of the panels.

**METHOD "A"** - One method for checking the roof for squareness is to measure diagonally across one slope of the roof from similar points at the ridge and eave and obtain the same dimension.

**METHOD "B"** - The 3-4-5 triangle system may also be used. To use this system measure a point from the corner along the edge of the roof at a module of three (3). Measure a point from the same corner along another edge at a module of four (4). Then by measuring diagonally between the two points established, the dimension should be exactly a module of five (5) to have a square corner. Multiple uses of this system may be required to determine building squareness. If the endwall cannot be made square, the roof system cannot be installed as shown in these instructions.

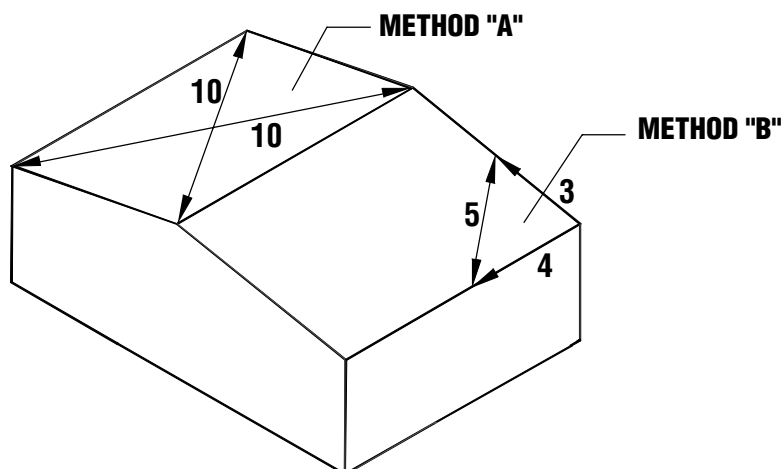

**VENTILATION**

Proper design and installation of vapor barriers and ventilation systems are important to prevent condensation and the resulting problems of moisture damage and loss of insulation efficiency.

On buildings that have an attic space, vents should be placed at both the eave and peak of the roof in order to prevent a buildup of moisture (humidity) in the attic space.

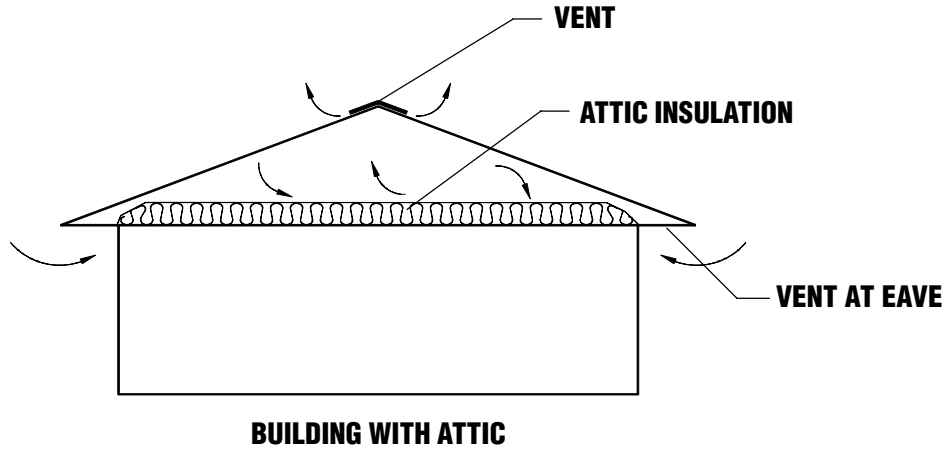

**FLASHING ANGLE SPECIFIER CHART**

This chart should be used to determine the required specified angle when considering the following Stile flashings.

PROFILE	FLASHING	1:12	2:12	3:12	4:12	5:12	6:12	7:12	8:12	9:12	10:12	11:12	12:12
	RIDGE	170°	161°	152°	143°	135°	127°	120°	113°	106°	100°	95°	90°
	VALLEY	173°	166°	160°	154°	148°	143°	138°	133°	129°	126°	123°	120°
	PITCH BREAK	94°	99°	104°	108°	112°	116°	120°	123°	126°	128°	132°	135°
	PEAK	87°	81°	76°	71°	67°	63°	60°	56°	53°	50°	47°	45°
	EAVE	94°	99°	104°	108°	112°	116°	120°	123°	126°	128°	132°	135°
	GUTTER	94°	99°	104°	108°	112°	116°	120°	123°	126°	128°	132°	135°

**ROOF SLOPE FACTOR CHART**

This chart should be used when specifying and ordering Panels and Flashings. It will help you determine overall required length of material on sloped applications.

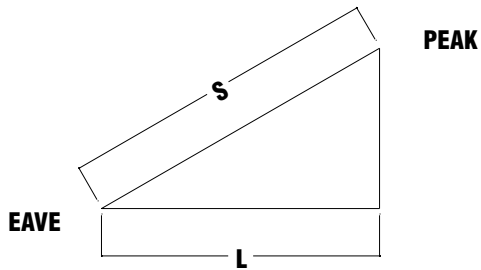

$(L) \times (\text{SLOPE FACTOR}) = S$

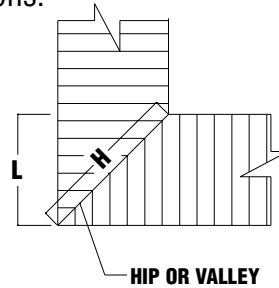

$(L) \times (\text{HIP VALLEY MULTIPLIER}) = H$

SLOPE	SLOPE FACTOR	HIP/VALLEY MULTIPLIER	SLOPE	SLOPE FACTOR	HIP/VALLEY MULTIPLIER
<b>1:12</b>	1.0035	1.4167	<b>7:12</b>	1.1577	1.5298
<b>2:12</b>	1.0138	1.4240	<b>8:12</b>	1.2019	1.5635
<b>3:12</b>	1.0308	1.4362	<b>9:12</b>	1.2500	1.6008
<b>4:12</b>	1.0541	1.4530	<b>10:12</b>	1.3017	1.6415
<b>5:12</b>	1.0833	1.4743	<b>11:12</b>	1.3566	1.6853
<b>6:12</b>	1.1180	1.5000	<b>12:12</b>	1.4142	1.7320

**EXAMPLE:**

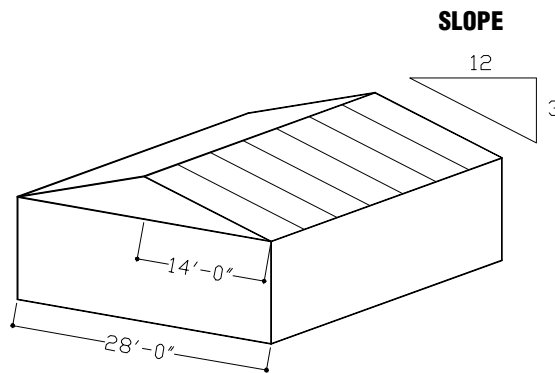
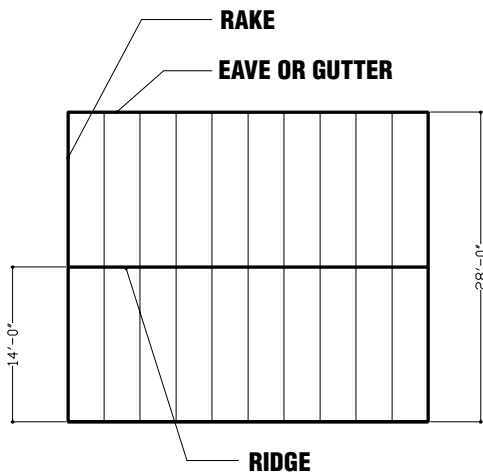

Your Building is 28'-0' wide with a 3:12 pitch.  
To determine the panel lengths for each side:

$(L) \times (\text{SLOPE FACTOR}) = S$

$14'-0'' \times 1.0308(\text{from chart above for } 3:12 \text{ slope}) = 14.4312' \quad \text{OR} \quad 14'-5''$

**STANDARD PACKAGING**

**BLOCKED AND BANDED** - This method is utilized for standard packaging of Stile roofing panels. Panels are stacked on a wood skid with a cover sheet on top. Boards are placed on top of the cover sheet. Banding is then placed around the skid, panel, and board.

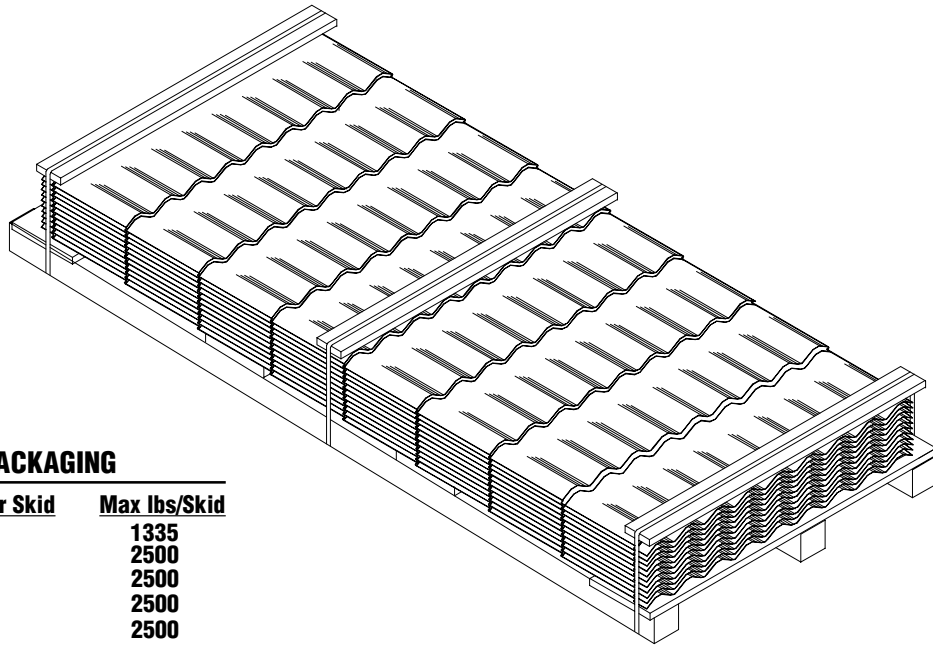

**STANDARD PACKAGING**

<u>Skid Length</u>	<u>Panels per Skid</u>	<u>Max lbs/Skid</u>
4'-0"	100	1335
8'-0"	95	2500
12'-0"	65	2500
16'-0"	50	2500
20'-0"	40	2500

**OPTIONAL PACKAGING**

**FULL CRATE** - This method is utilized for all LTL and overseas shipments or at customer's request.

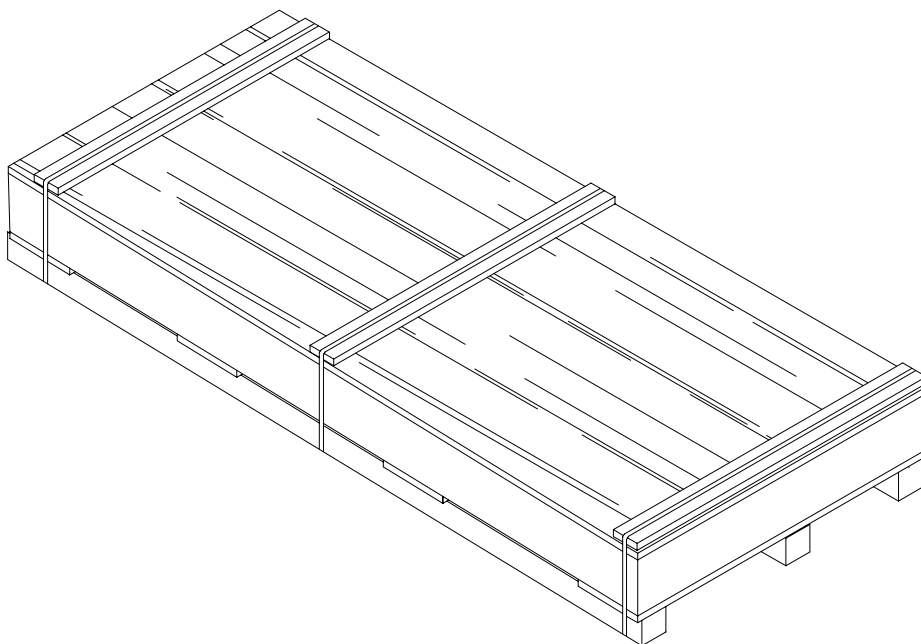



## RECEIVING MATERIAL

It is the responsibility of the installer to unload material from the delivery truck. The installer is not responsible for providing suitable equipment for unloading of material from the delivery truck.

After receiving material, check the condition of the material, and review the shipment against the shipping list to ensure all materials are accounted for. If damages or shortages are discovered, it should be noted on the Bill of Lading at the time of delivery. A claim should be made against the carrier as soon as possible. Metal Sales is not responsible for any damages or shortages unless they are documented in writing and presented to Metal Sales within 48 hours.

## GENERAL HANDLING

**CAUTION**

Improper loading and unloading of bundles and crates may result in bodily harm and/or material damage. Metal Sales is not responsible for bodily injuries and/or material damages resulting from improper loading and unloading.

Each bundle should be handled carefully to avoid being damaged. Care should be taken to prevent bending of the panel or abrasion to finish. Whenever possible, the bundle should remain crated until it is located in its place of storage. If bundles must be opened, we recommend you recreate them before lifting. To avoid damage please lift the bundle at its center of gravity.

Some products may have a peel-off (strippable film) plastic coating over the painted surface. This coating was factory applied to prevent damage to the finish that may occur during manufacturing or shipping. If this coating is present, avoid exposure of the "strippable film" parts to sunlight and remove the "strippable film" prior to installation.

## MECHANICAL HANDLING

**FORKLIFT** - A forklift may be used for panels up to 20'-0" long. Please make sure the forks are at their maximum separation. Do not transport open bundles. When transporting bundles across rough terrain, or over a longer distance, some means of supporting the panel load must be used.

**CRANE** - A crane should be used when lifting panels with lengths greater than 20'-0". Please be sure to utilize a spreader bar to ensure the even distribution of the weight to the pick up points. As a rule when lifting panels, no more than  $\frac{1}{3}$  of the length of the panel should be left unsupported. Never use wire rope as this will damage the panels.

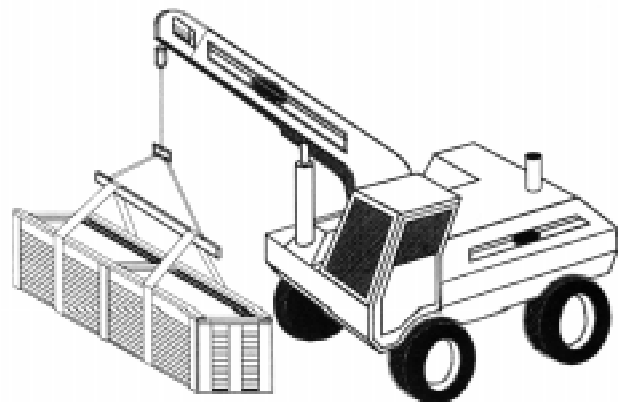
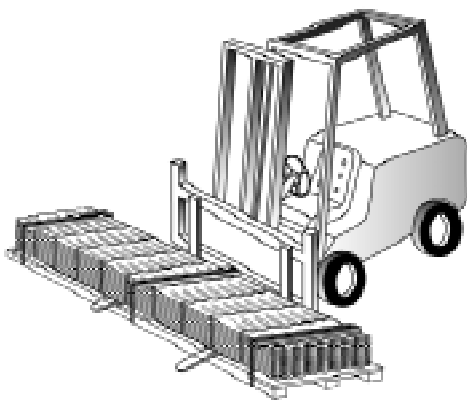

## MANUAL HANDLING

Installers should wear rubber sole shoes to keep from scuffing material while walking on the roof.

Handling of individual panels should be done carefully and properly to avoid bending or damaging. Stile panels should be carried by grasping the edge of the panel so that the Stile panel is vertical to the ground. The panel should not be carried with the flat of the panel horizontal to the ground as this could cause the panel to buckle or bend in the center.

Normally two people can handle panels easily. The weight of a 20'-0" Stile panel is approximately 66 pounds.

**CORRECT**

**INCORRECT**

## GENERAL

Please inspect panels for moisture accumulation. If moisture has formed, the panels should be un-bundled, wiped dry, and allowed to dry completely. Once dry, carefully restack the panels and loosely recover allowing for ample air circulation.

Bundled sheets should be stored high enough off of the ground to allow for air circulation and prevent contact with accumulating water. If possible, elevate one end of the bundle to allow any moisture to run off the panels. Metal Sales recommends covering the bundle with a tarpaulin. Do not use tight fitting plastic-type tarpaulins as panel bundle covers. While they may provide protection from heavy downpours, they can also retard necessary ventilation and trap heat and moisture that may accelerate metal corrosion. If panels are to be stored in possible bad weather, we suggest they be stored inside. Extended storage of panels in a bundle is not recommended. **Under no circumstances should the sheets be stored near or come in contact with salt water, corrosive chemicals, ash or fumes generated or released inside the building or nearby plants, foundries, plating works, kilns, fertilizer, and wet or green lumber.**

## FOOT TRAFFIC

Care of metal panels and flashings must be exercised throughout erection. Foot traffic can cause distortion of panel and damage to finish. Traffic over the installed system must be kept to an absolute minimum. Installers should wear rubber sole shoes to keep from scuffing material while walking on the roof.

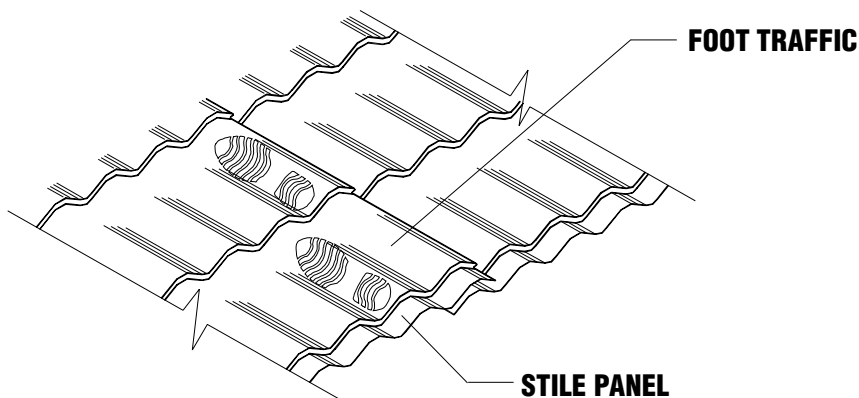

**CAUTION**  
Avoid walking on  
panels when wet.

## FIELD CUTTING

Tin snips or a "nibbler" type electric tool are recommended for field cutting Stile panels. Cutting the steel generates slivers or metal chips. These slivers and metal chips must be immediately removed from the Stile panels because they will damage the finish and shorten the life of the product.

One method of preventing this problem is to flip the Stile panels over when cutting. This allows the slivers and metal chips to be brushed from the back side and avoids damaging the paint on the top side of the panels.

**CAUTION**

All product surfaces should be free of debris at all times. Installed surfaces should be wiped clean at the end of each work period. Never cut panels over metal surfaces. Metal shavings will rust on the surface, voiding the warranty.

## TOUCH-UP PAINT

All painted panels and flashings have a factory applied baked on finish. Handling and installing panels may result in some small scratches or nicks to the paint finish. Touch-up paint is available in matching colors from Metal Sales. It is recommended that a small brush be used to apply touch-up paint to those areas that are in need of repair. Touch-up paint does not have the superior chalk and fade resistance of the factory applied paint finish and will normally discolor at an accelerated rate. Aerosol paint should not be used



SPRAY PAINT

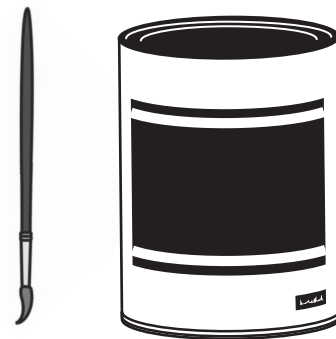

TOUCH-UP PAINT

**EAVE OR GUTTER**

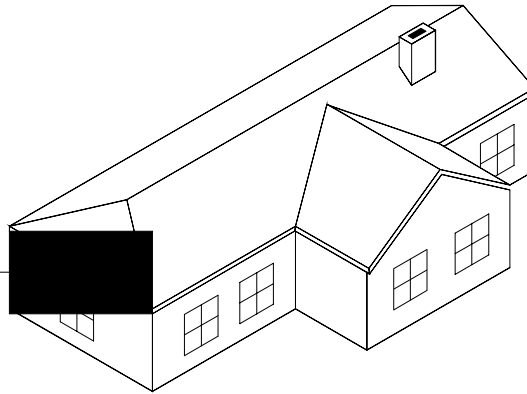

1. Attach Eave or Gutter flashing starting at the edge of the roof and extending the length of the eave.
2. Fasten the top leg of the Eave or Gutter flashing to the roof decking with a Woodscrew XL fastener placed 1" from the edge of the eave. Fasteners should be placed on 5'-0" centers along the Eave or Gutter flashing to provide temporary attachment of the flashing until the roof panels are installed. Eave or gutter flashings should overlap the previously installed piece by 3".

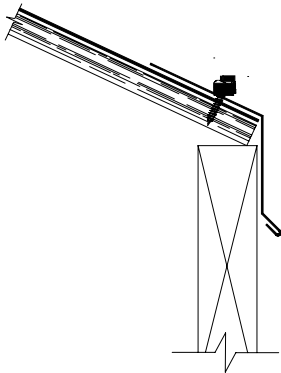

**SIMPLE EAVE**

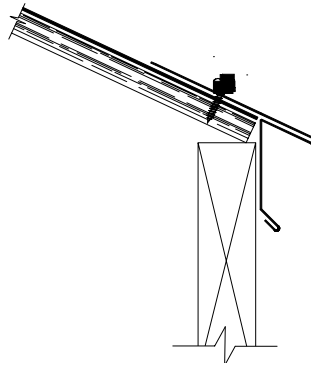

**EXTENDED EAVE**

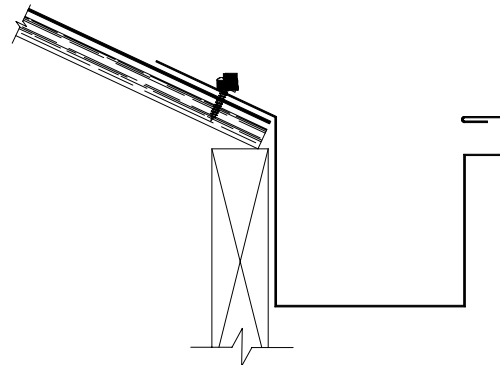

**EAVE WITH GUTTER**

3. Once the Eave or Gutter flashing has been attached, the Stile Starter may be installed. The Stile Starter is recommended to help the installer maintain straight panel appearance at the eave of the building by providing a reference line at the first panel step. The Stile Starter is placed 2" back from the eave and extends the length of the eave. Attach the Stile Starter to the roof with a Woodscrew XL fastener placed 3'-0" o.c. Lapping of the Stile Starter is not required.

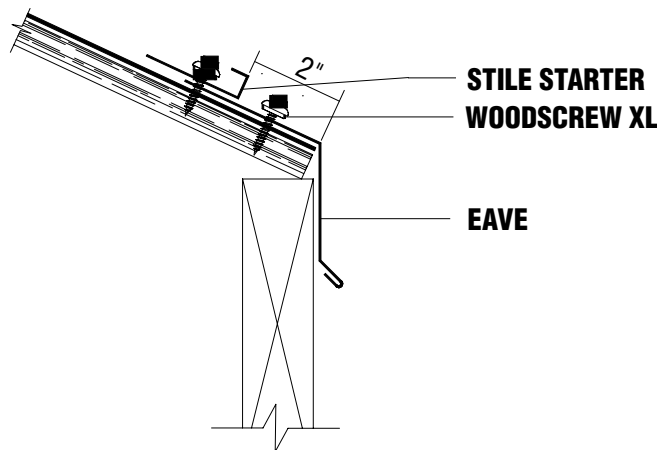

\*Follow the same procedures for use with the gutter flashing

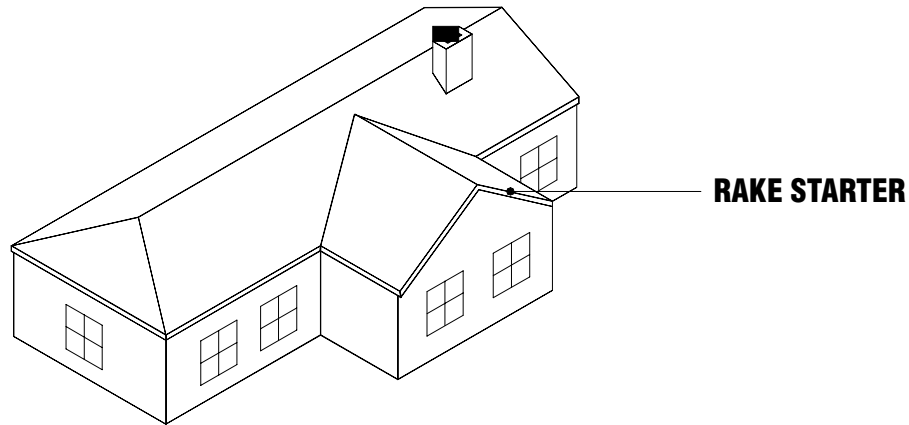

1. Install the Rake Starter along the edge of the roof beginning at the eave and stopping at the ridge. Align the vertical leg of the Rake Starter flush with the edge of the rake. Attach with a Woodscrew XL fastener in the extended leg of the trim 3" up from the eave. Place fasteners along the Rake Starter 1'-0" o.c.
2. If two or more Rake Starters are required, lap the flashing over the previously installed flashing by a minimum of 3" placing a bead of Tube Sealant between the flashings along the edge where they lap. The last Rake Starter should be field cut  $\frac{1}{2}$ " from the ridge. The final fastener on this run should be located 3" down from the ridge.

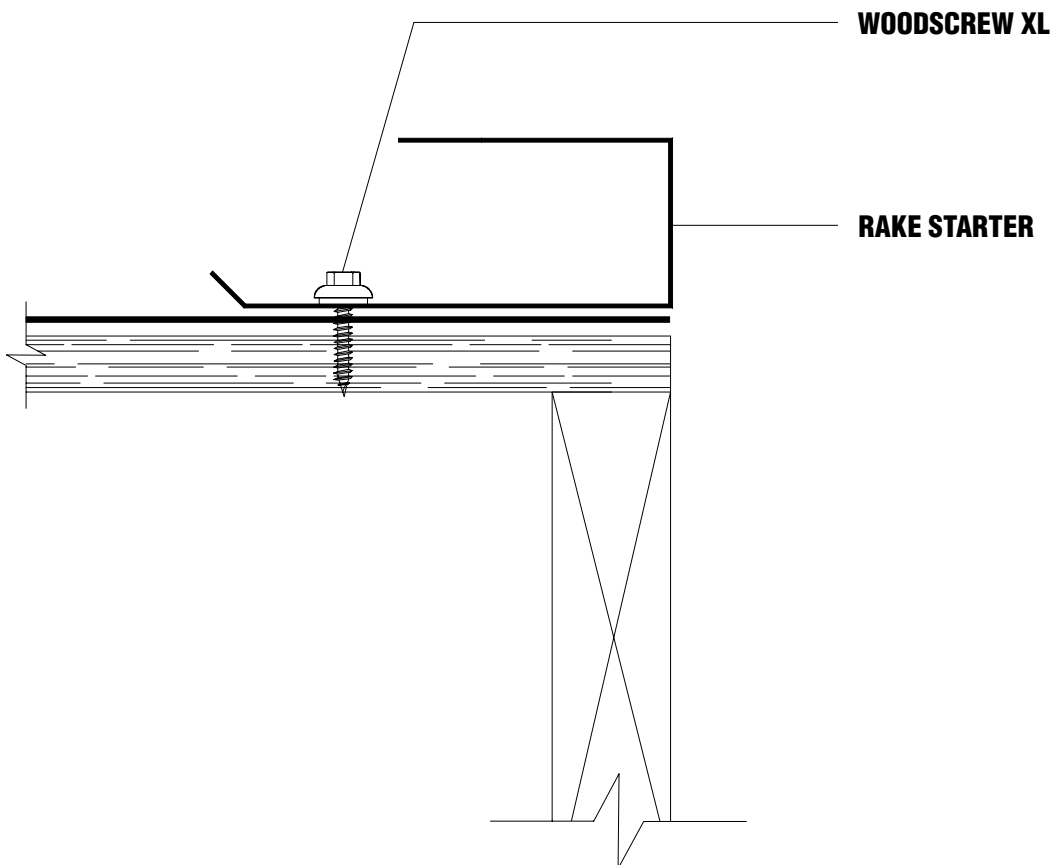

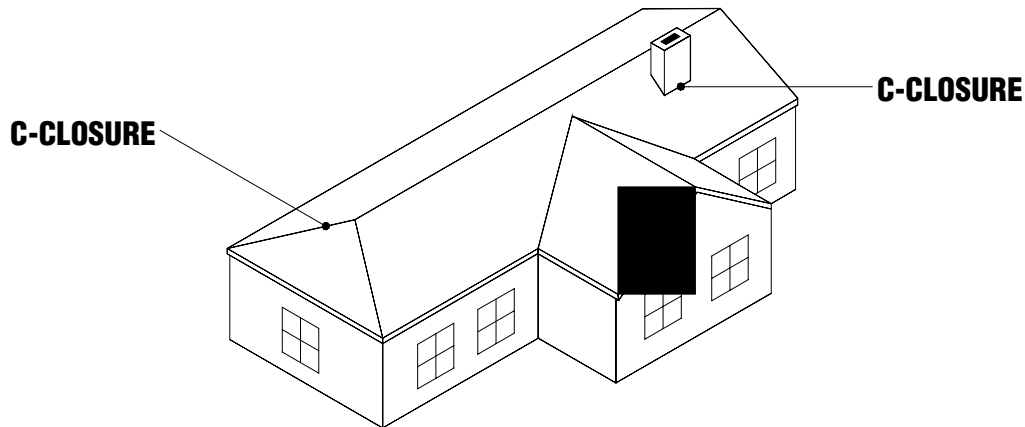

1. In applications where a hip or high side parapet is involved, a Stile C-Closure is used at the termination of the panel. **When Formed Ridge flashing is used Stile C-Closure flashing is not required.**
2. Install the Stile C-Closure along the length of the hip or parapet 2" below the highest point (for hip condition a Stile C-Closure is required on both sides of the hip).
3. If two or more Stile C-Closures are required, lap the flashing over the previously installed flashing by a minimum of 3" placing a bead of Tube Sealant between the flashings along the edge where they lap. Attach Stile C-Closure to the roof deck with Woodscrew XL fasteners placed 12" o.c.

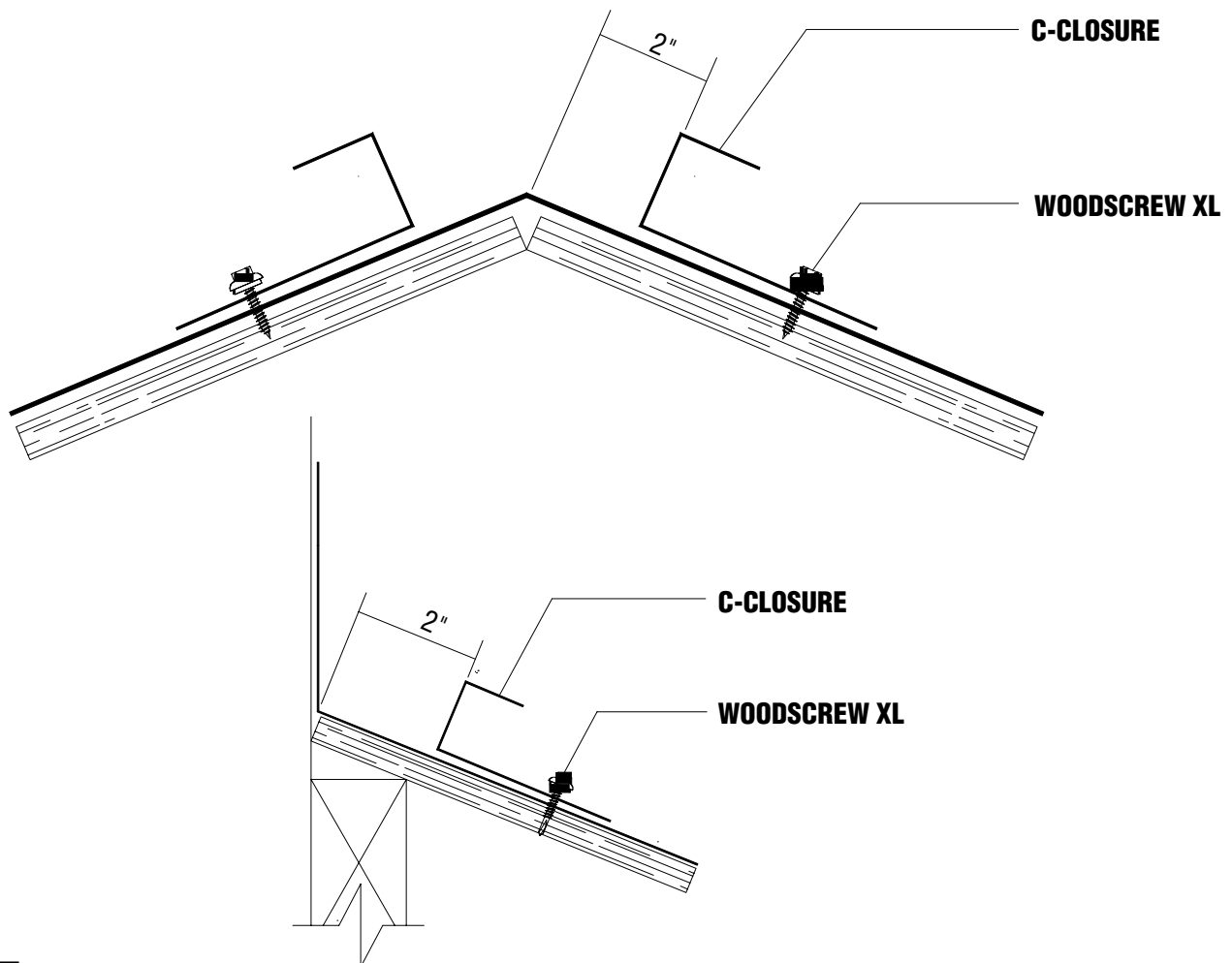

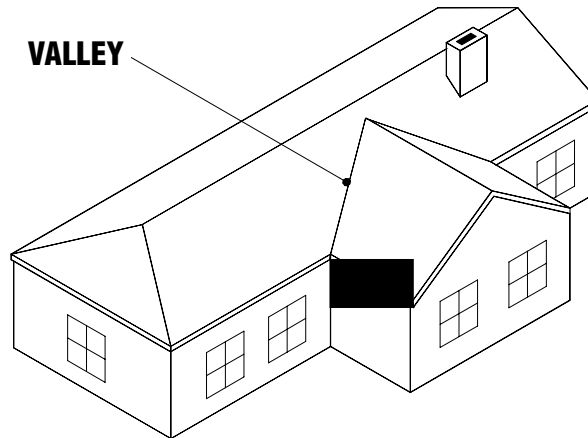

1. Begin by installing a sheet of 36" wide Ice and Water Shield in the valley so that it extends up each side of the valley 18".
2. Place Valley flashing over the Ice and Water Shield starting at the eave and working upward towards the ridge.
3. If two or more Valley flashings are required, lap the flashing over the previously installed flashing by a minimum of 12" placing a bead of Tube Sealant between the flashings along the edge where they lap.
4. Place Woodscrew XL fasteners at 2'-0" o.c. 1" from the top edge of the Valley flashing on each side of the valley.

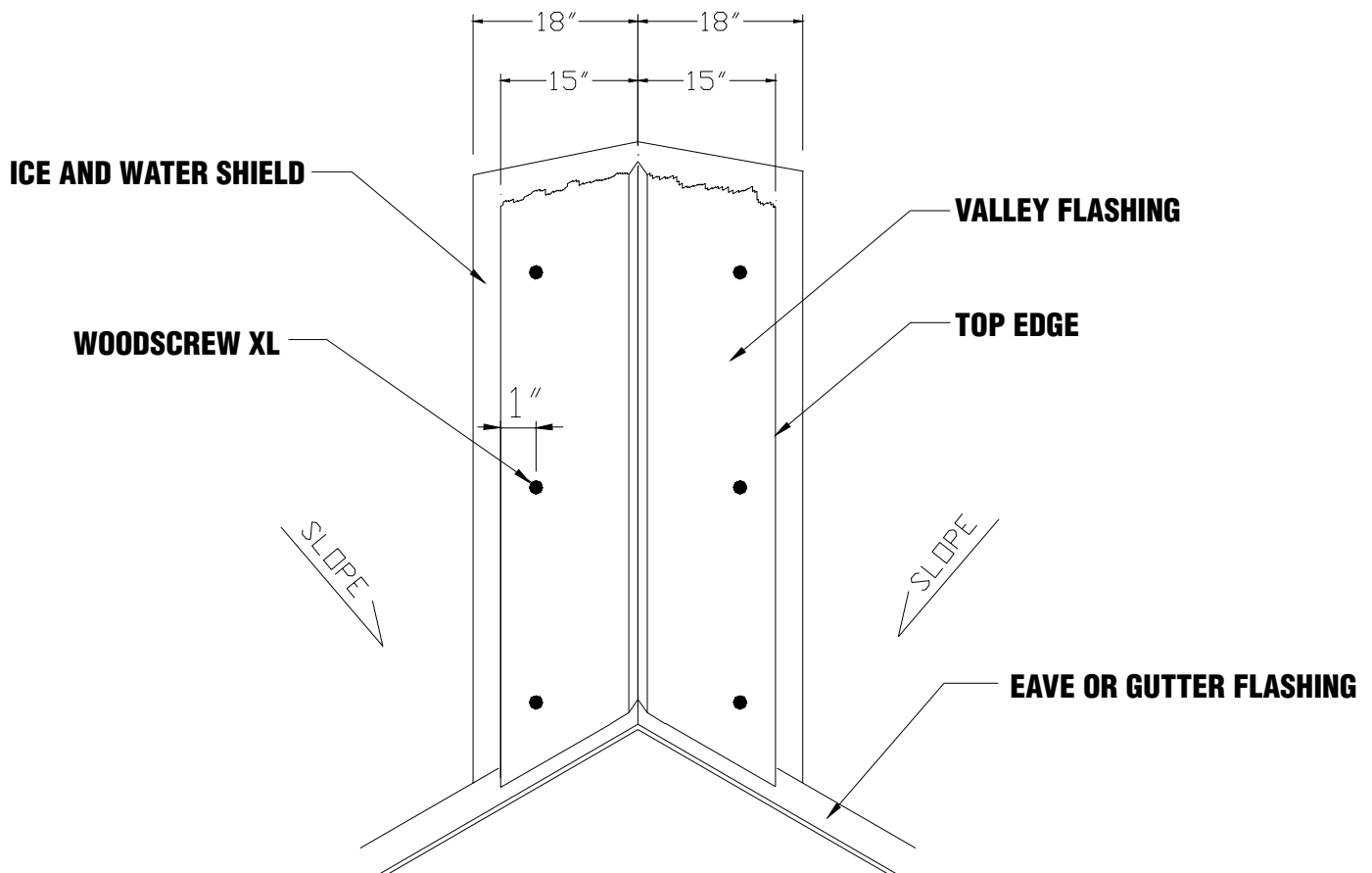



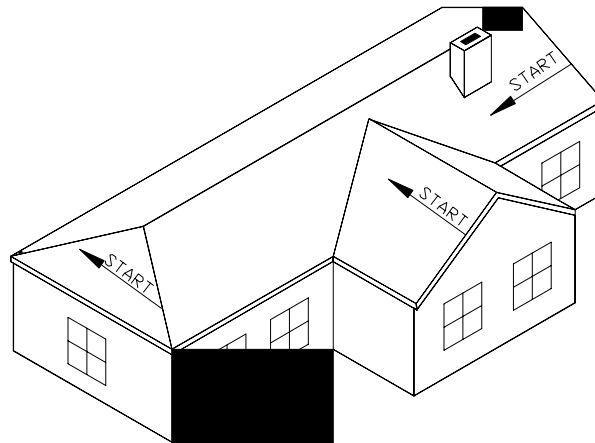

1. **Stile panels must be installed from right to left.**
2. When starting at a rake, slide the panel into the opening of the previously installed Rake Starter until it hits the vertical leg of the flashing.
3. Align the Stile panel with the eave allowing the bottom leg of the sheet to extend  $\frac{1}{2}$ " over the edge of the eave. **It is important to tilt the right side of the panel  $\frac{1}{16}$ " lower than the left side.** This is required to keep the panel thickness from accumulating at the eave and can be easily accomplished by simply placing a  $\frac{1}{16}$ " spacer between the Stile Starter and the first step on the right side of the Stile panel.

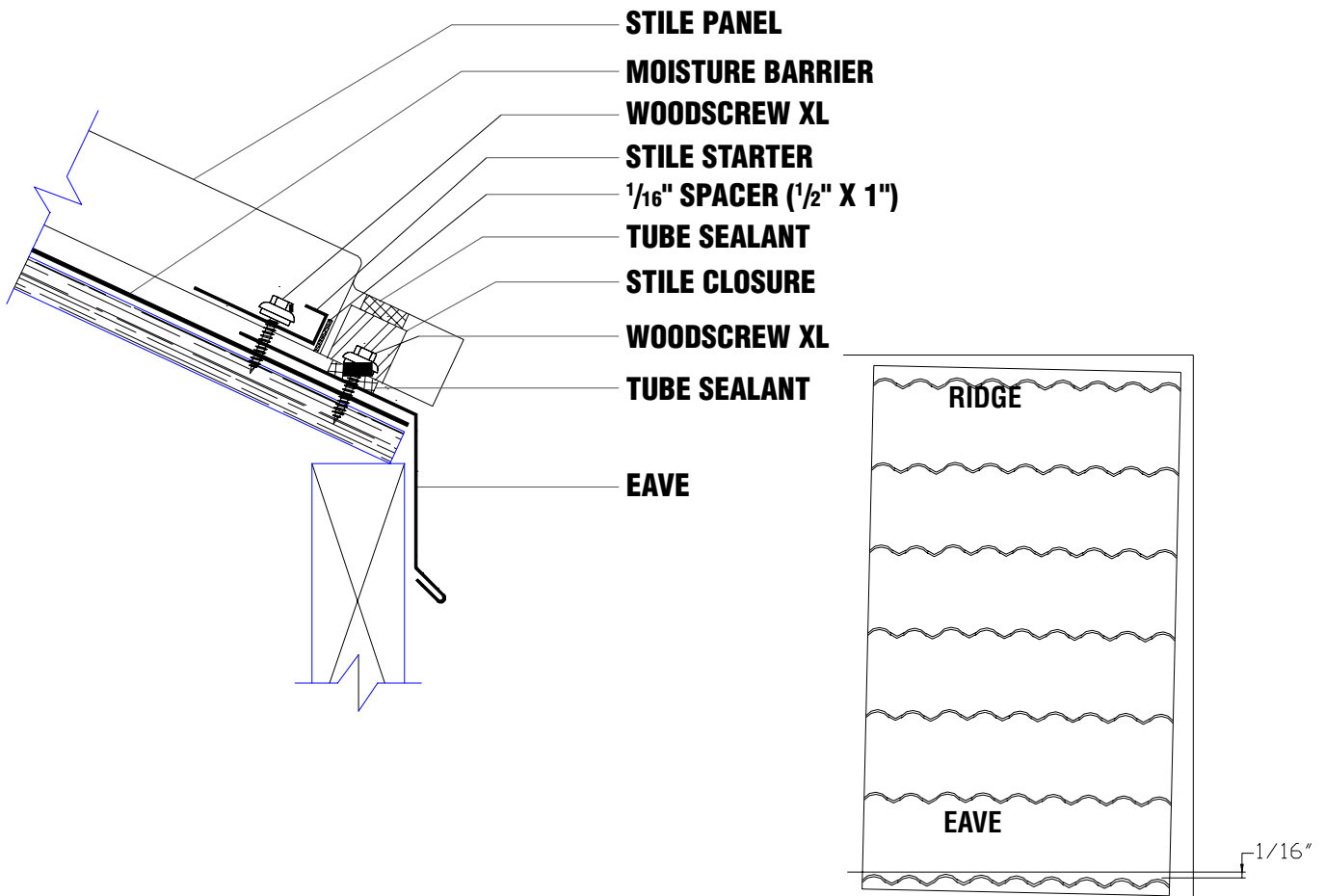

**FASTENING OF PANEL**

1. After placement of the first panel is established, a Stile Closure with Tube Sealant is placed at the eave flush with the Stile panel.
2. Fastening of the panel can begin by placing a Woodscrew XL fastener in the first valley of the Stile panel in the bottom leg just below the step. Place a second fastener in the first valley of the Stile panel three steps up from where the first fastener was placed. Continue placing fasteners up the length of the panel in the first valley of every third step. Do not place a fastener in the last step of the panel if the run is longer than one panel and requires an endlap.
3. Place a fastener at every other valley and every third step over the remainder of the panel.
4. Complete the fastening of the panel to the roof deck by placing a fastener in every valley of the Stile panel at the eave, ridge, or peak.

**FASTEN EVERY VALLEY AT RIDGE OR PEAK**

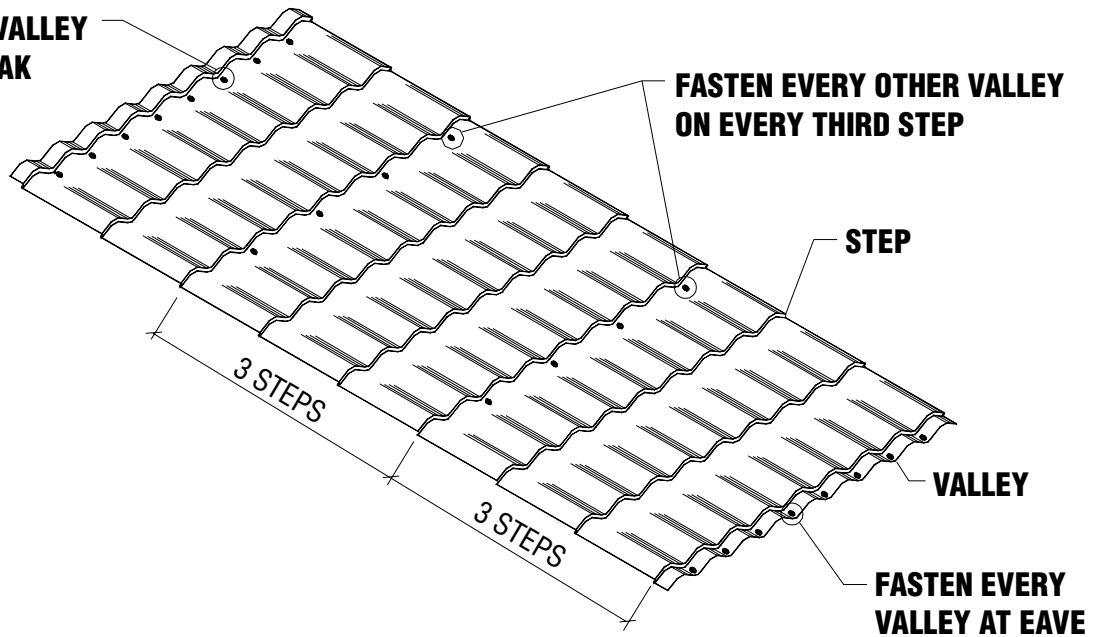

**STILE CLOSURE (EAVE CONDITION SHOWN)**

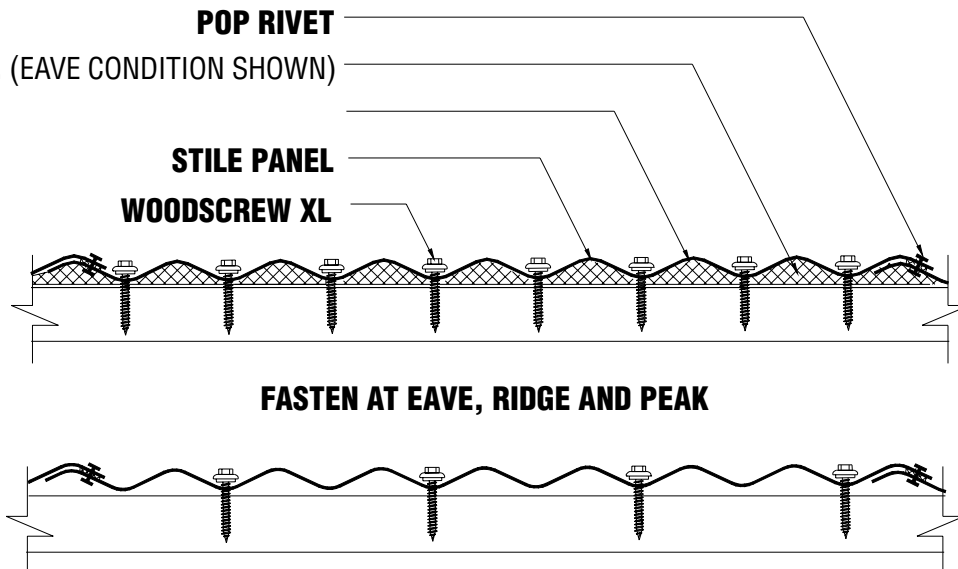

## SIDELAPPING OF PANEL

1. **Stile panels are installed from right to left.** Once the first Stile panel is in place, install the second panel by lapping the right side of the panel over the last rib of the previously installed panel.
2. Align the sidelap of the panels and check proper seating of the panels at the lap and eave.
3. Apply Stile Closure and fasten panel to roof deck following the same pattern as the first panel. All panels thereafter will be installed in the same manner as the first few panels.
4. Placement of  $\frac{1}{8}$ " Pop Rivet and Tube Sealant is optional at the panel sidelap. Recommended spacing of the Pop Rivet is every 12" along the sidelap.

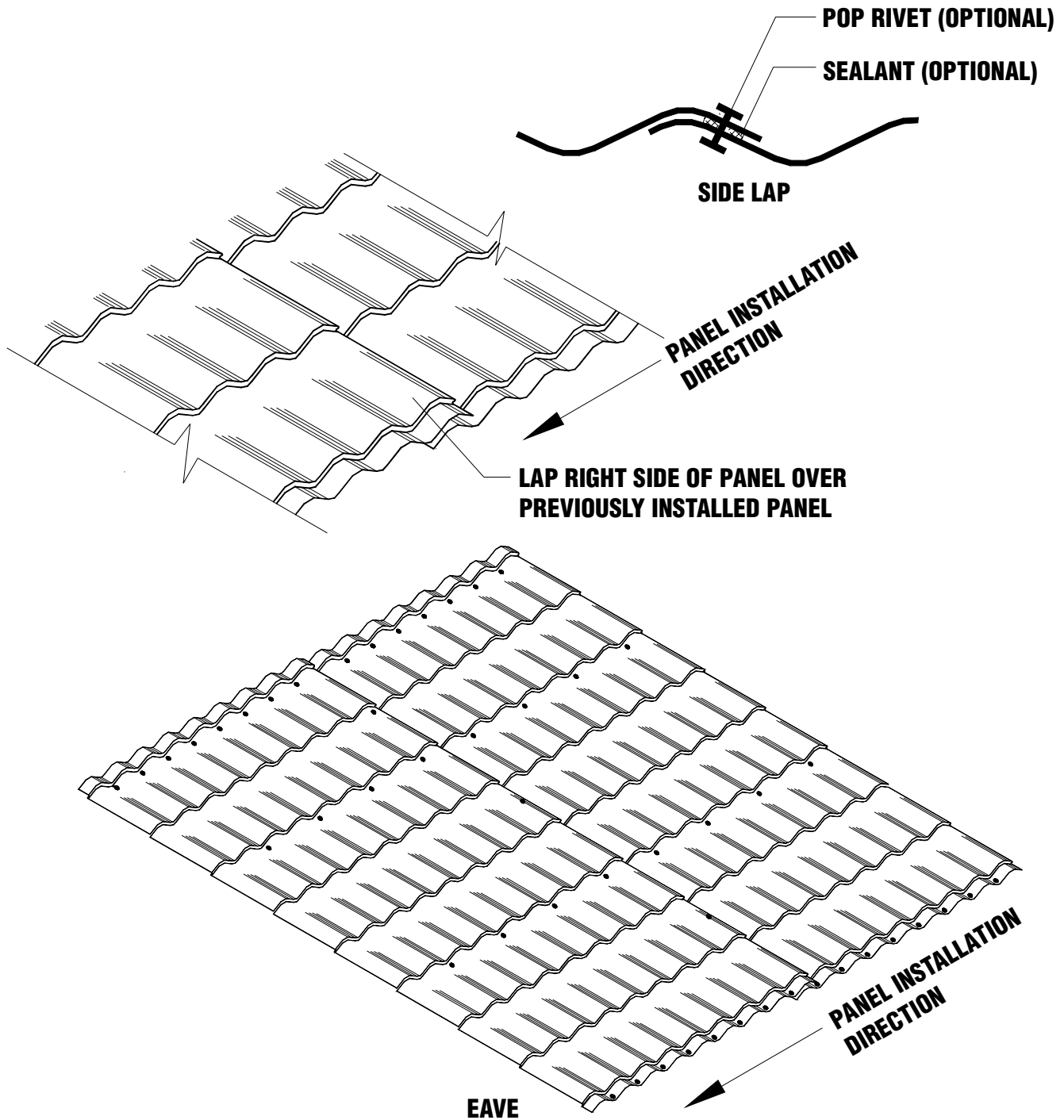

**ENDLAPPING OF PANEL**

1. Stile panels are available in lengths from 3'-0" to 20'-0" in one foot increments. For runs longer than 20'-0", panels are designed to endlap.
2. Endlaps can be placed staggered or in-line with the previous panel endlap. Either method of installation is suitable, but in-line endlapping tends to be easier to order and install.
3. Follow the panel installation sequence as shown below. Regardless of which method you use, install panels from right to left, lapping the ridge panel over the eave panel.
4. Fasten panels with a Woodscrew XL fastener at every other valley and every third step of the panel (see page 25). Fasten at the endlap in every valley just below the step in the panel.

**PANEL INSTALLATION DIRECTION**

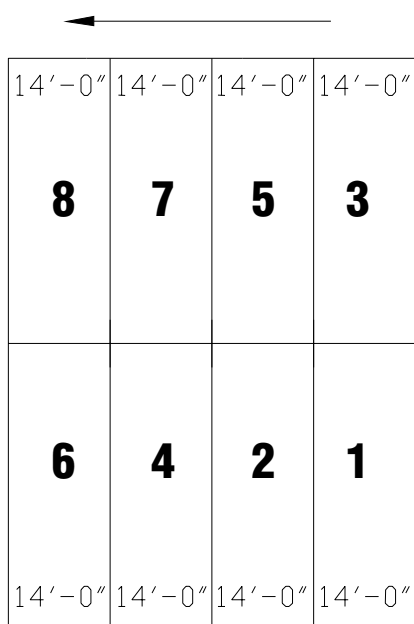

**IN-LINE ENDLAPPING**

In an in-line endlap example a 28'-0" run would be covered with 14'-0" panels at both the top and the bottom of the run.

**PANEL INSTALLATION DIRECTION**

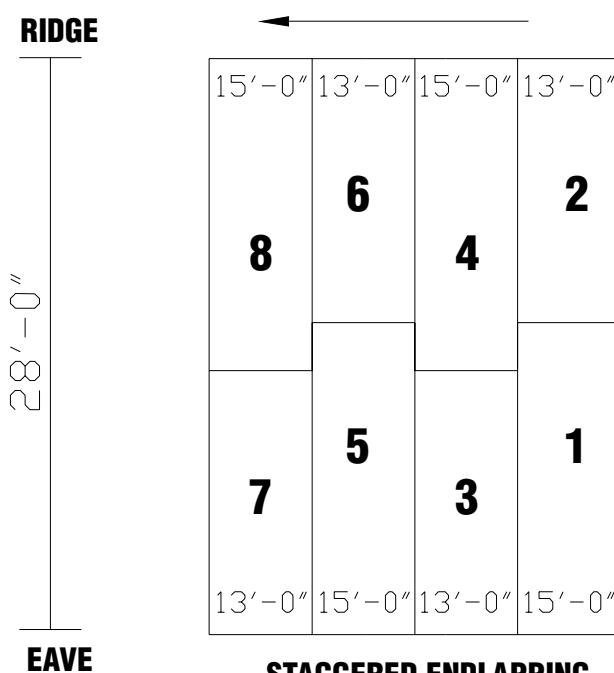

**STAGGERED ENDLAPPING**

In a staggered endlap example a 28'-0" run would be covered with panel lengths of 15'-0" and 13'-0" alternating right to left.

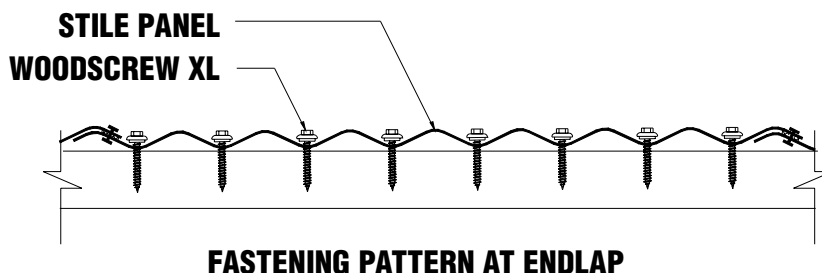
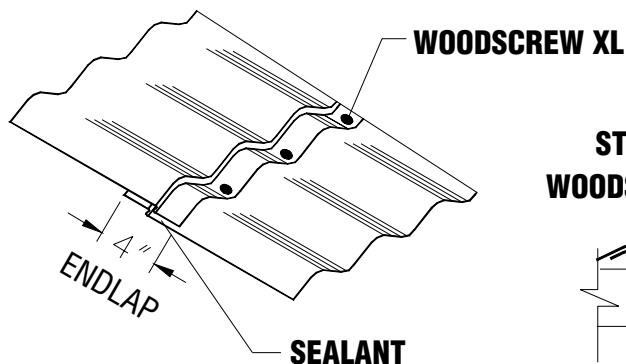

## PANEL AT VALLEY CONDITION

1. All Stile panels meeting the valley must be field cut at an angle so that the panels stop 3" from the center of the valley.
2. When starting Stile panel near a valley, tilt the right side of the panel  $\frac{1}{16}$ " lower than the left side. This is required to keep the panel thickness from accumulating at the eave (see page 24).
3. A foam Universal Closure or Stile Closure is placed between the previously installed Valley flashing and Stile panel. Tube Sealant is used with the closure to prevent moisture and debris from getting under the panels.
4. Woodscrew XL fasteners are required along the edge of the cut panel just below each step.
5. Place a fastener at every other valley and every third step throughout the panel.
6. Optional Valley Cover is installed over the Stile panel at the valley. Fasten the Valley Cover to the rib of the Stile panel with a  $\frac{1}{8}$ " Pop Rivet on both sides of the Valley Cover at 1'-0" o.c.

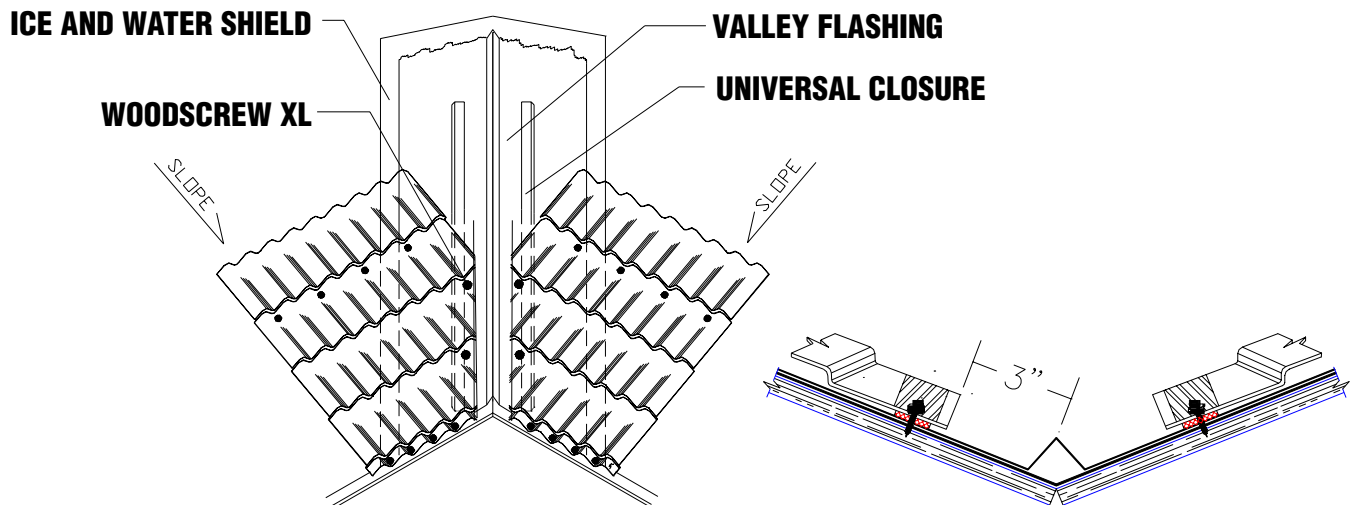

## PANEL AT HIP CONDITION

1. All panels meeting the hip must be field cut at an angle so that the Stile panel fits into the previously installed Stile C-Closure (see page 22). When Formed Ridge flashing is used, Stile C-Closure is not required.
2. When starting Stile panel near a hip, tilt the right side of the panel  $\frac{1}{16}$ " lower than the left side. This is required to keep the panel thickness from accumulating at the eave (see page 24).
3. Woodscrew XL fasteners are required along the edge of the cut panel just below each step.
4. Place a fastener at every other valley and every third step throughout the panel.

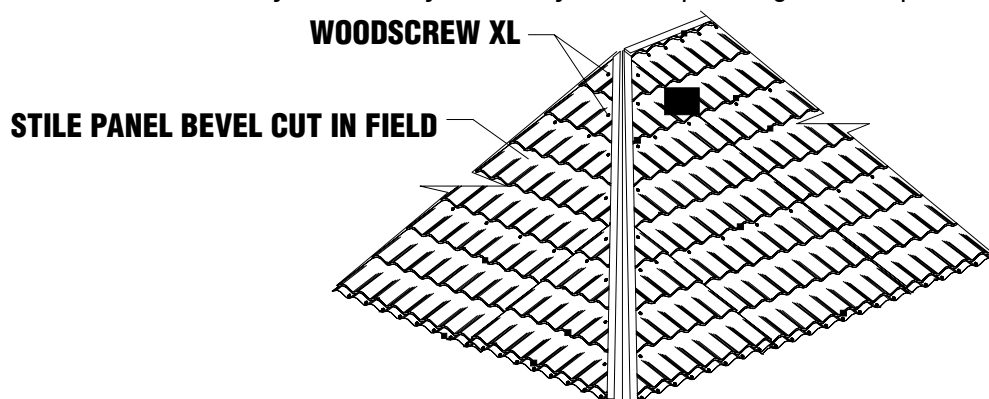

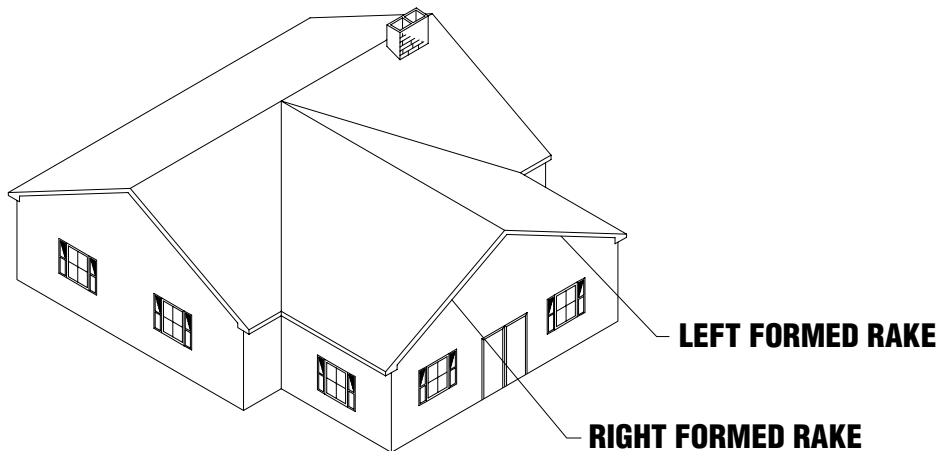

**RAKE CONDITION**

1. After the Stile panel has been installed in the opening of the Rake Starter, fasten the upper leg of the Rake Starter to the Stile panel rib with a 1/8" Pop Rivet.
2. Pop Rivets are placed directly over the high point of the panel at each step.

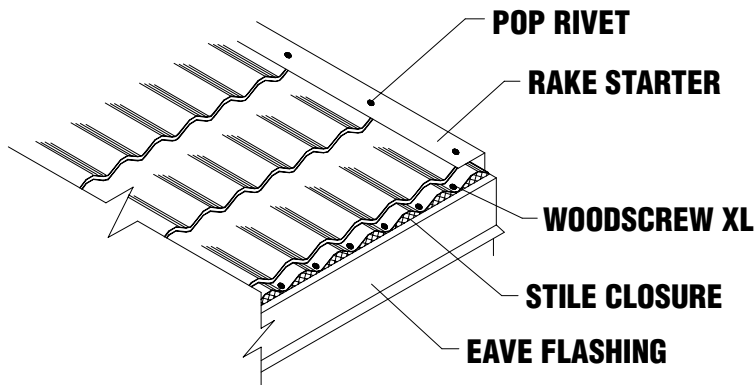

3. Starting at the eave install the Formed Rake over the Rake Starter. The lip on the top flange of the Formed Rake fits over the top leg of the Rake Starter.
4. Rotate the Formed Rake down so that the lower flange extends down onto the rake board or siding.
5. Attach the bottom flange of the Formed Rake with a Woodscrew XL fastener below each step on the flashing. The last step of the flashing should not be fastened until the next piece of Formed Rake is overlapped.
6. At the peak of the rake, the two pieces of Formed Rake will need to be cut at an angle so they fit neatly together. Apply Tube Sealant where the Formed Rake flashings meet each other and fasten with three 1/8" Pop Rivets.

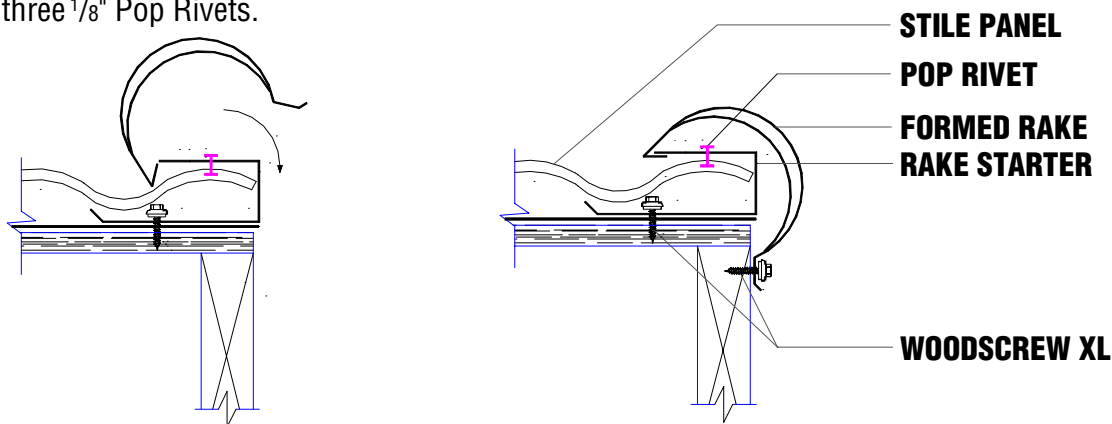

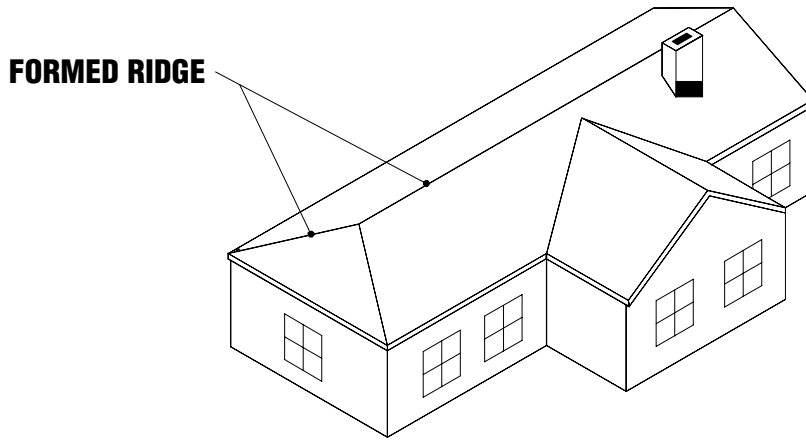

**SIMPLE RIDGE CONDITION**

1. Position the Formed Ridge at the peak of the roof and square with the front edge of the Formed Rake.
2. Align the Formed Ridge so that the flanges extend down on each side of the roof equal distance.
3. Place Stile Closure under the flange on each side of the Formed Ridge.
4. Place 1/8" Pop Rivet in the flange of the Formed Ridge so that the Formed Ridge is fastened to the Stile panel at the top of every other rib of the panel. Do not install the last fastener until the next piece of Formed Ridge has been overlapped with the installed Formed Ridge.
5. After all the Formed Ridge has been installed, close off the ridge at each end of the roof by placing a Ridge Closure End Plug in the open area.

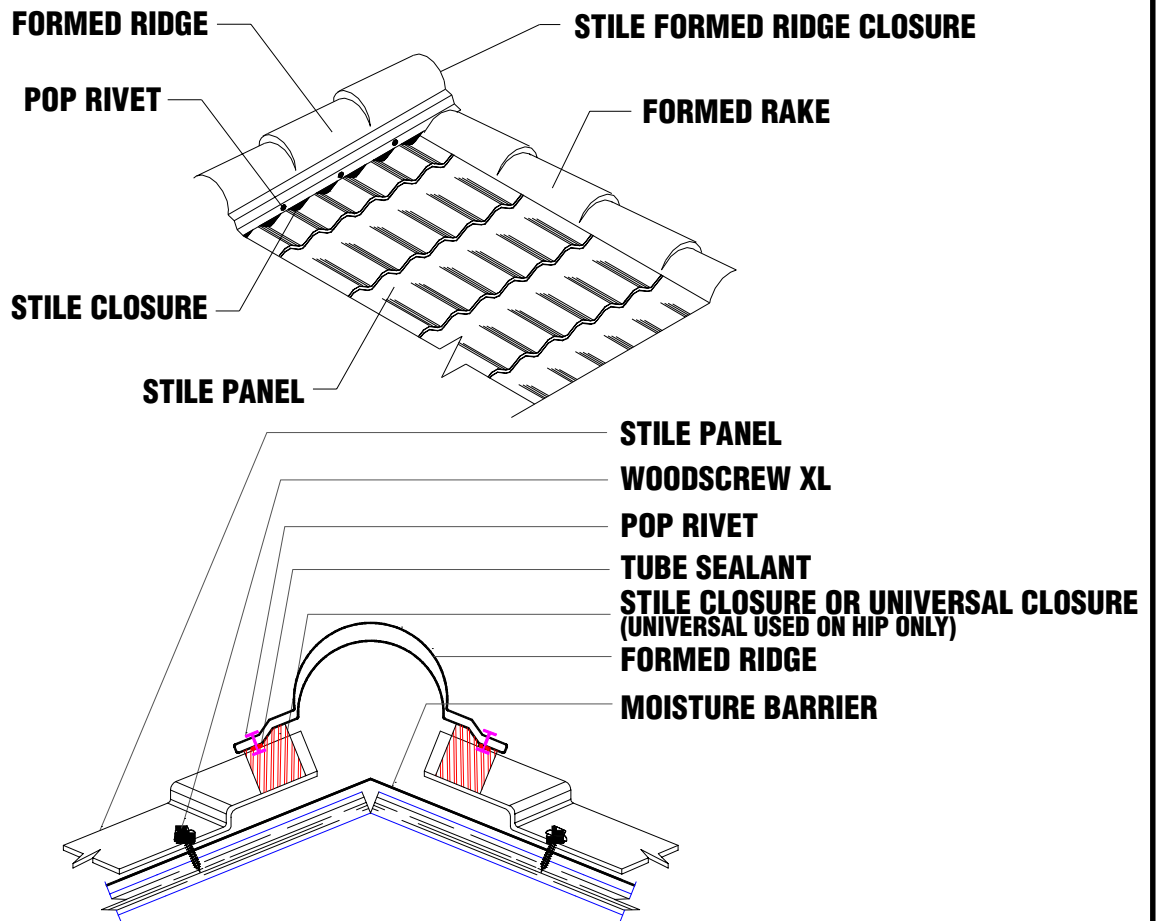

## HIP CONDITION

1. It will be necessary to field cut the ends of the three pieces of Formed Ridge where they intersect.
2. The Formed Ridge on the first hip should be cut at approximately a 45 degree angle at the corner where it will intersect with the Formed Ridge of the second hip.
3. The Formed Ridge on the second hip will then need to be cut at an angle so that it neatly joins the Formed Ridge on the first hip.
4. Place foam Universal Closure under the flanges of the Formed Ridge where they meet the Stile panel.
5. Place Tube Sealant where the two pieces of Formed Ridge meet each other.
6. Fasten the Formed Ridge at the hip with a 1/8" Pop Rivet to the top of each panel rib.
7. The Formed Ridge on the ridge of the roof should now be installed and trimmed so as to fit neatly over the Formed Ridge on the hips.
8. Install Stile Closure under the flange on each side of the Formed Ridge.
9. Fasten Formed Ridge at the ridge with a 1/8" Pop Rivet to the top of every other panel rib.

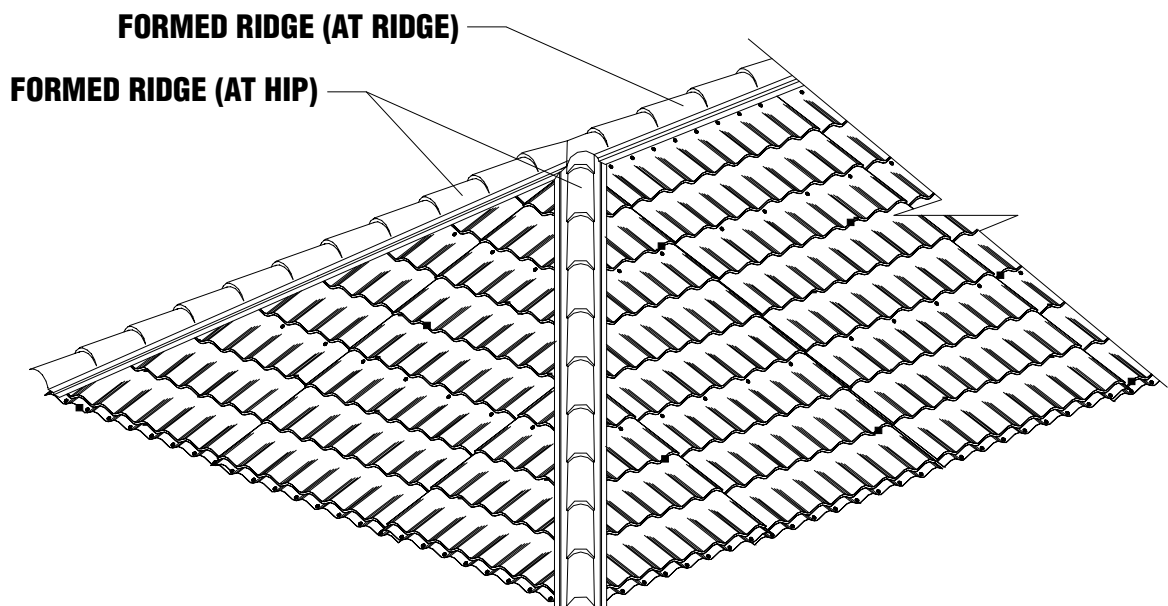
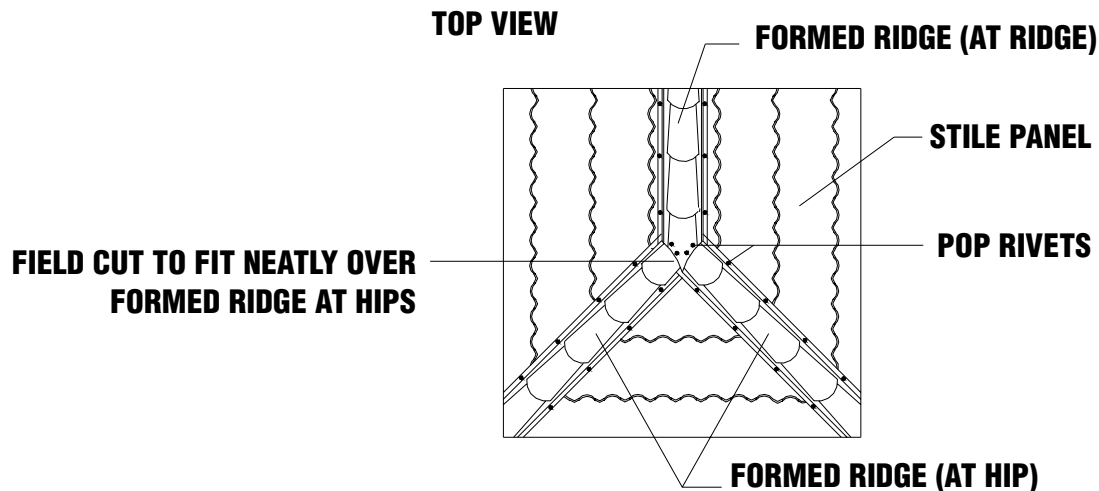



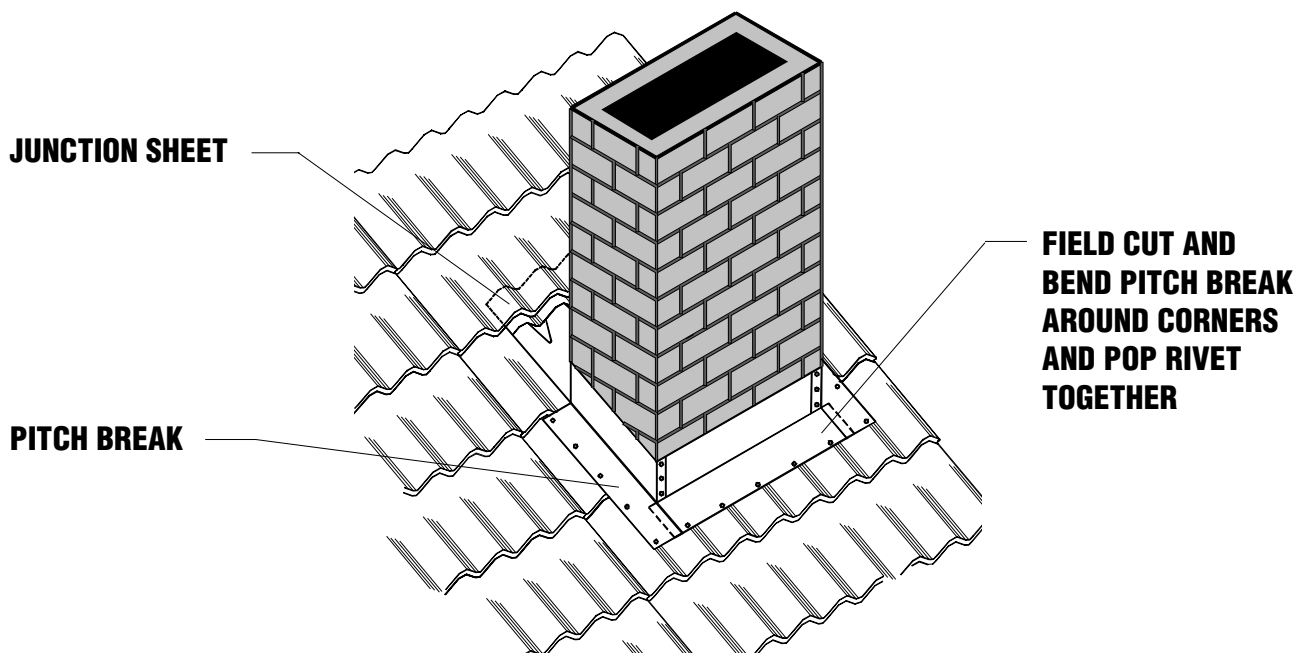

1. Roofing felt should extend up the sides of the penetration at least 6" and fit snugly around all sides of the penetration.
2. Stile panels should be field cut so that they fit close to the penetration on the sides and lower end. The top Stile panel should be cut so that it stops 6" from the penetration at the upper end so as to allow the Junction Sheet to fit properly.
3. Cut three pieces of Pitch Break flashing so that each piece extends 6" past each end of the penetration. Cut a slit at the base of each end of the Pitch Break flashing so that the 6" section can be bent around the edge of the projection to form a corner.
4. Install Pitch Break flashing at the lower end of the penetration. Place Stile C-Closure between the bottom leg of the Pitch Break flashing and the Stile panel.
5. Install Pitch Break flashing on each side of the penetration, lapping it over the installed piece at the corners. Place Tube Sealant between the bottom leg of the Pitch Break flashing and the Stile panel.
6. The Junction Sheet will next be installed at the top edge of the penetration. Field cut the Junction Sheet so that it extends 6" past the penetration on each side.
7. Fit the formed section of the Junction Sheet under the lower leg of the Stile panel. Bend the flat section of the Junction Sheet so that it extends up the back of the penetration. The Junction Sheet should be cut so that it extends 6" past each side of the penetration. Cut a notch in the base of this section so that it can be bent to form a corner.
8. Place Tube Sealant between the two flashings where they overlap at the corner of the penetration and at the top edge of the flashing.
9. Attach the Pitch Break flashing to the Stile panel with 1/8" Pop Rivets at the top of each panel rib and at the top of each step of the sides of the penetration. The Junction Sheet is attached to the Stile panel with a Woodscrew XL fastener at the bottom of each valley of the panel.
10. Use 1/8" Pop Rivets to fasten the two pieces of flashing together at each of the corners of the penetration.
11. Apply field formed cricket to junction sheet with 1/8" x 3/16" pop rivets and two beads of tube sealant.

**RUBBER ROOF JACK**

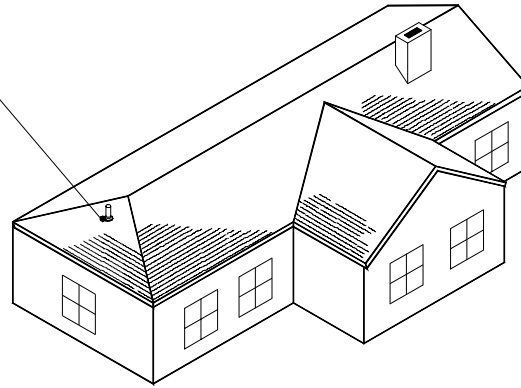

- 1 On vent pipe penetrations, the roofing felt should fit very tightly around the penetration.
2. Take the appropriate measurements for the vent location and mark them on the Stile panel. Cut the Stile panels to fit the opening properly.
3. Once the Stile panels are applied, flash the vent pipe with a Rubber Roof Jack or similar pipe flashing.
4. Apply Tube Sealant between the panel and the base of the Rubber Roof Jack as well as the area around the top where the boot meets the pipe.
5. Attach the base of the Rubber Roof Jack to the panel using 1/4 - 14 x 7/8" Stitch fasteners.

**WOODSCREW XL**

**STILE PANEL**

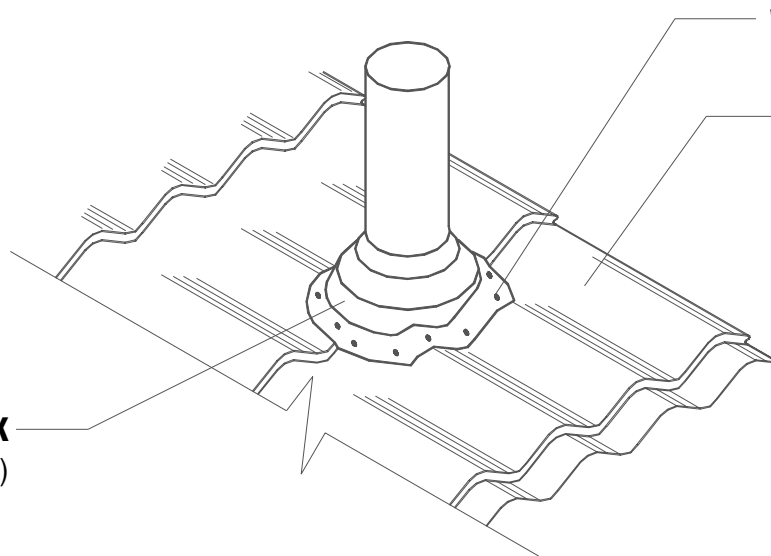

**RUBBER ROOF JACK**  
(APPLY SEALANT AROUND BASE)

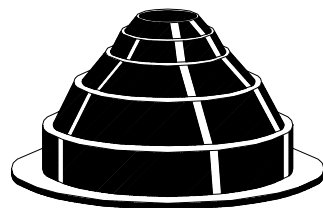

- #2 (1 3/4" TO 3" O.D. PIPE)**
- #3 (3" TO 6" O.D. PIPE)**
- #6 (6" TO 9" O.D. PIPE)**
- #8 (7" TO 13" O.D. PIPE)**

# STILE INSTALLATION OF STILE ROOF VENT

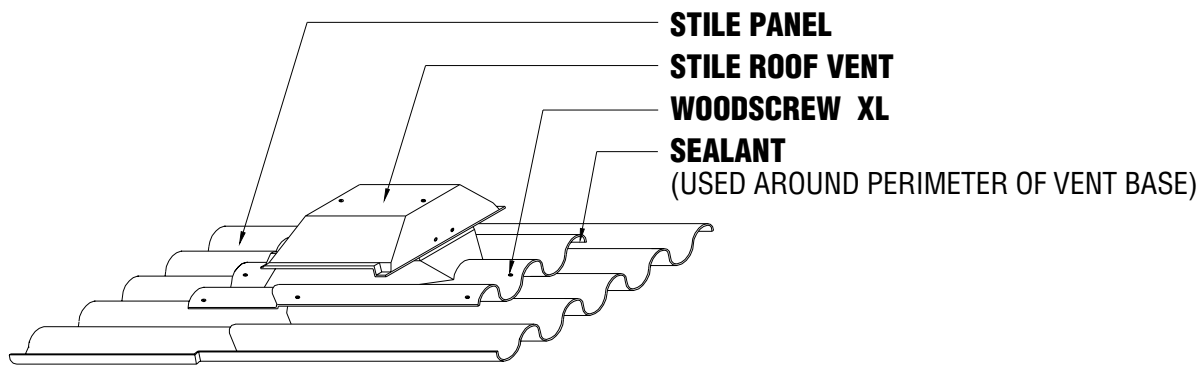

## STILE ROOF VENT

The Stile Roof Vent allows compliance with many new venting regulations and is suitable for new construction and reroofing. The Stile Roof Vent offers 31 square inches of ventilation area and complies with Uniform Building Code requirements. In all cases the installer should conform to applicable building codes for that area. The base of the Stile Roof Vent is formed with the same profile as the Stile panel for ease of installation.

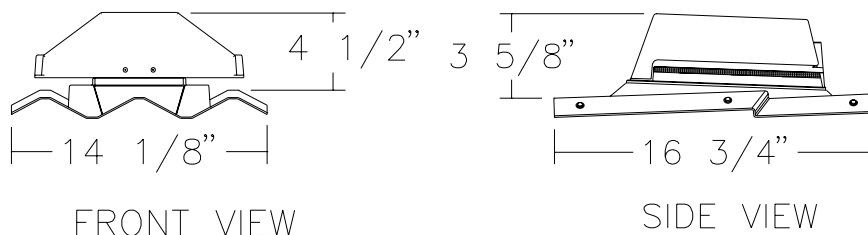

## USED AS AN ATTIC VENT

1. It is recommend that the Stile Roof Vent location be determined after the Stile panel is installed.
2. Select location and mark where the vent base rests on the Stile panel.
3. Measure, mark, and cut a 9" wide and 16" long rectangular vent opening in the Stile panel.
4. Measure, mark, and cut the 5" x 8" opening in the plywood decking.
5. Apply two continuous beads of Tube Sealant on the panel 1/2" from the marks made for the base. This should form a rectangle slightly smaller than the vent.
6. Fit the Stile Roof Vent back in place and press it down firmly so that the Tube Sealant forms a weathertight seal. Fasten the Stile Roof Vent to the Stile panel using ten WoodscREW XL fasteners. The fasteners should be placed 1" from the sides and ends of the Stile Roof Vent .

# STILE CONDITION DETAIL EXPLANATION

The following pages depict Metal Sales' suggested Stile details and are for illustration purposes only. These details may not be applicable to all conditions or designs.

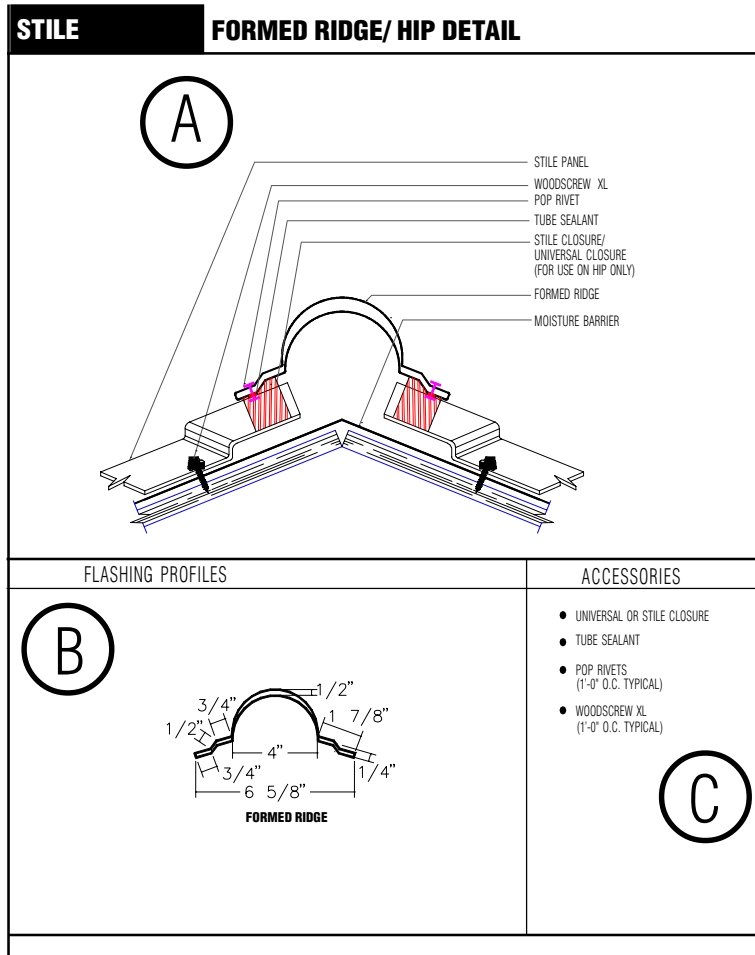

## EXPLANATION OF CONDITION PAGES

The condition pages contain a clear illustration of the various flashing details, illustrations of all necessary manufactured components, and a listing of the remaining components necessary to assemble the flashing condition.

- Refers to Metal Sales' suggested flashing condition detail. This illustration shows the correct component placement for each detail.
- Refers to Metal Sales' standard manufactured flashing profiles required to assemble the flashing condition. These components are fully illustrated and discussed.
- Refers to Metal Sales' accessories required to assemble the flashing condition.

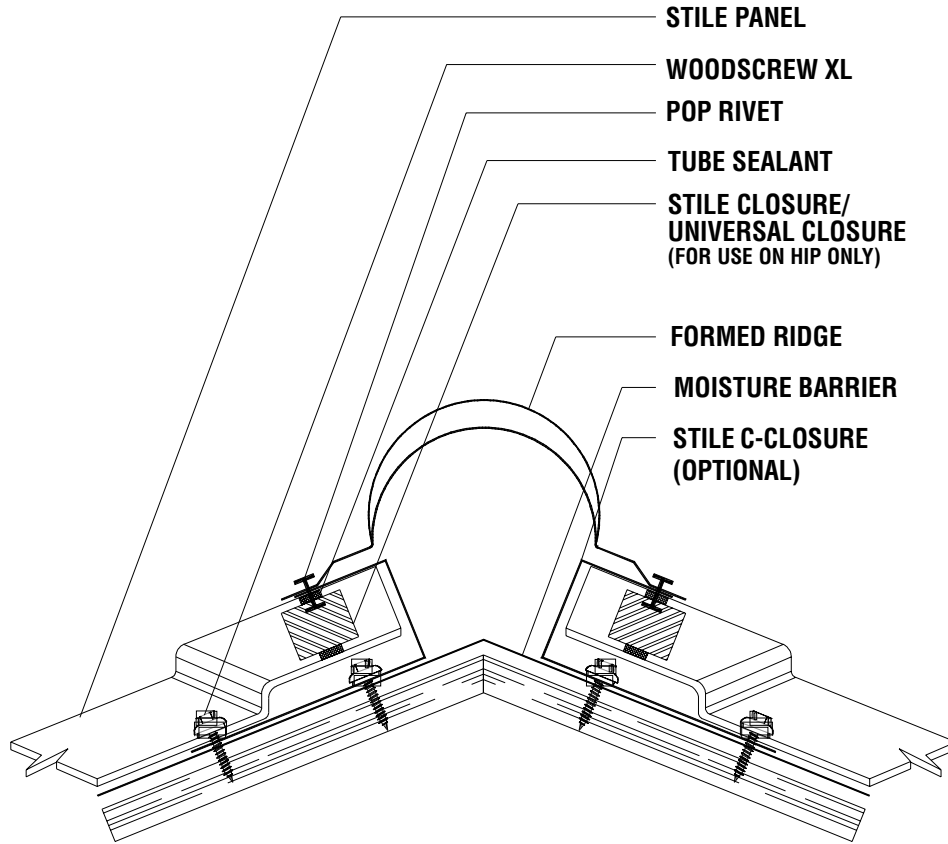

**FLASHING PROFILES**

**ACCESSORIES**

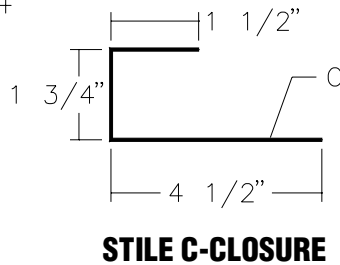
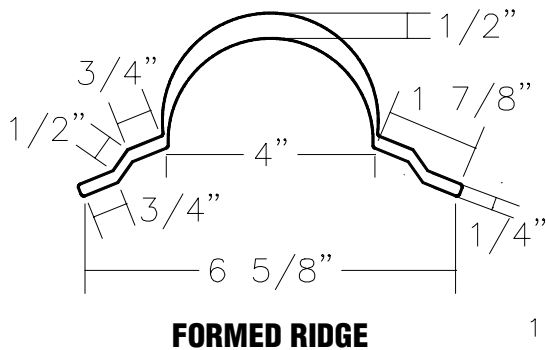

- **UNIVERSAL OR STILE CLOSURE**
- **TUBE SEALANT**
- **POP RIVETS**  
(1'-0" O.C. TYPICAL)
- **WOODSCREW XL**  
(1'-0" O.C. TYPICAL)

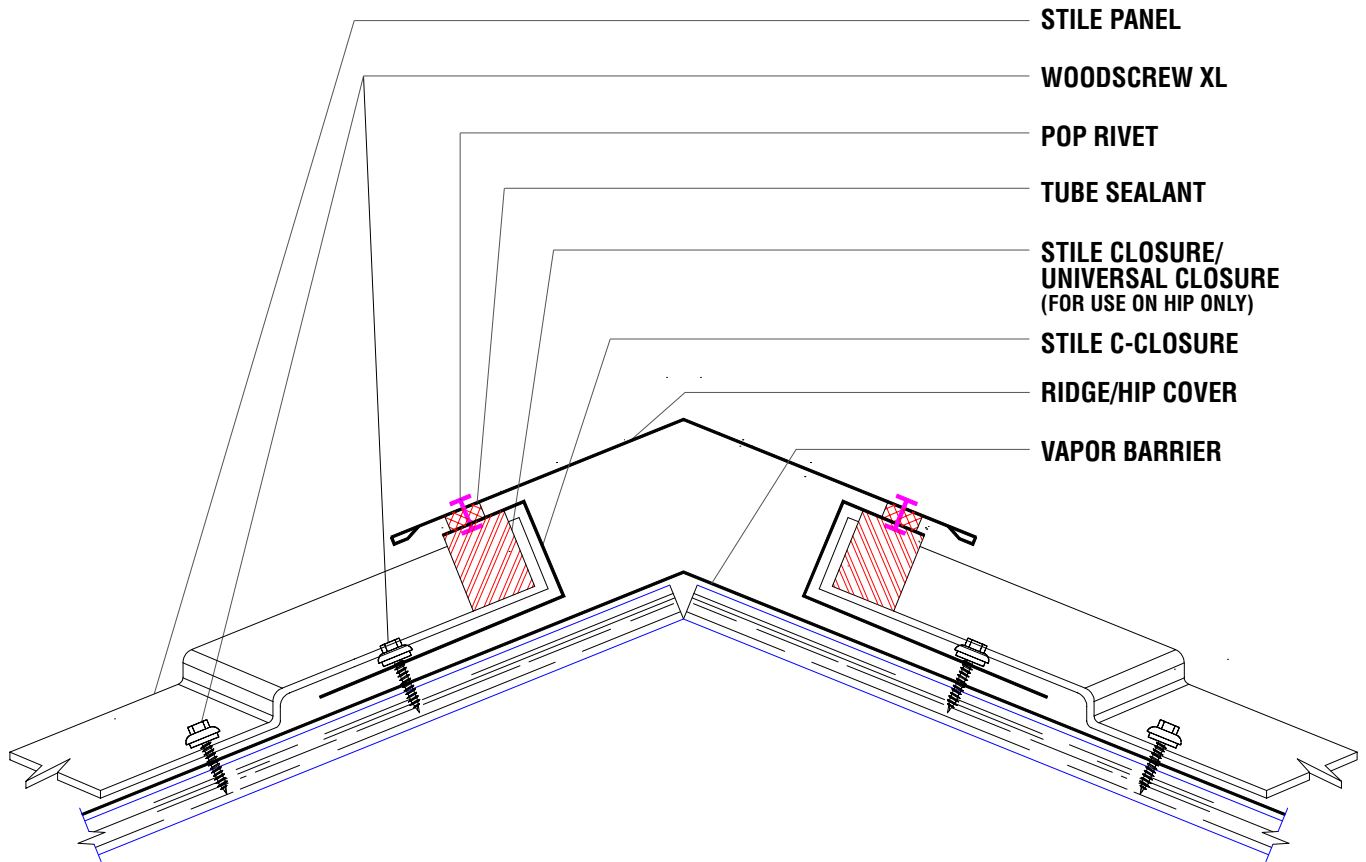

**FLASHING PROFILES**

**ACCESSORIES**

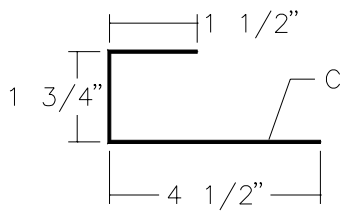

**STILE C-CLOSURE**

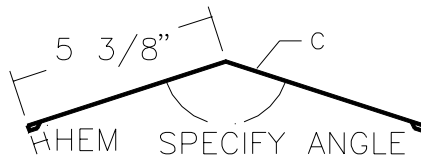

**RIDGE/HIP COVER**

- **UNIVERSAL OR STILE CLOSURE**
- **TUBE SEALANT**
- **POP RIVETS**  
(1'-0" O.C. TYPICAL)
- **WOODSCREW XL**  
(1'-0" O.C. TYPICAL)

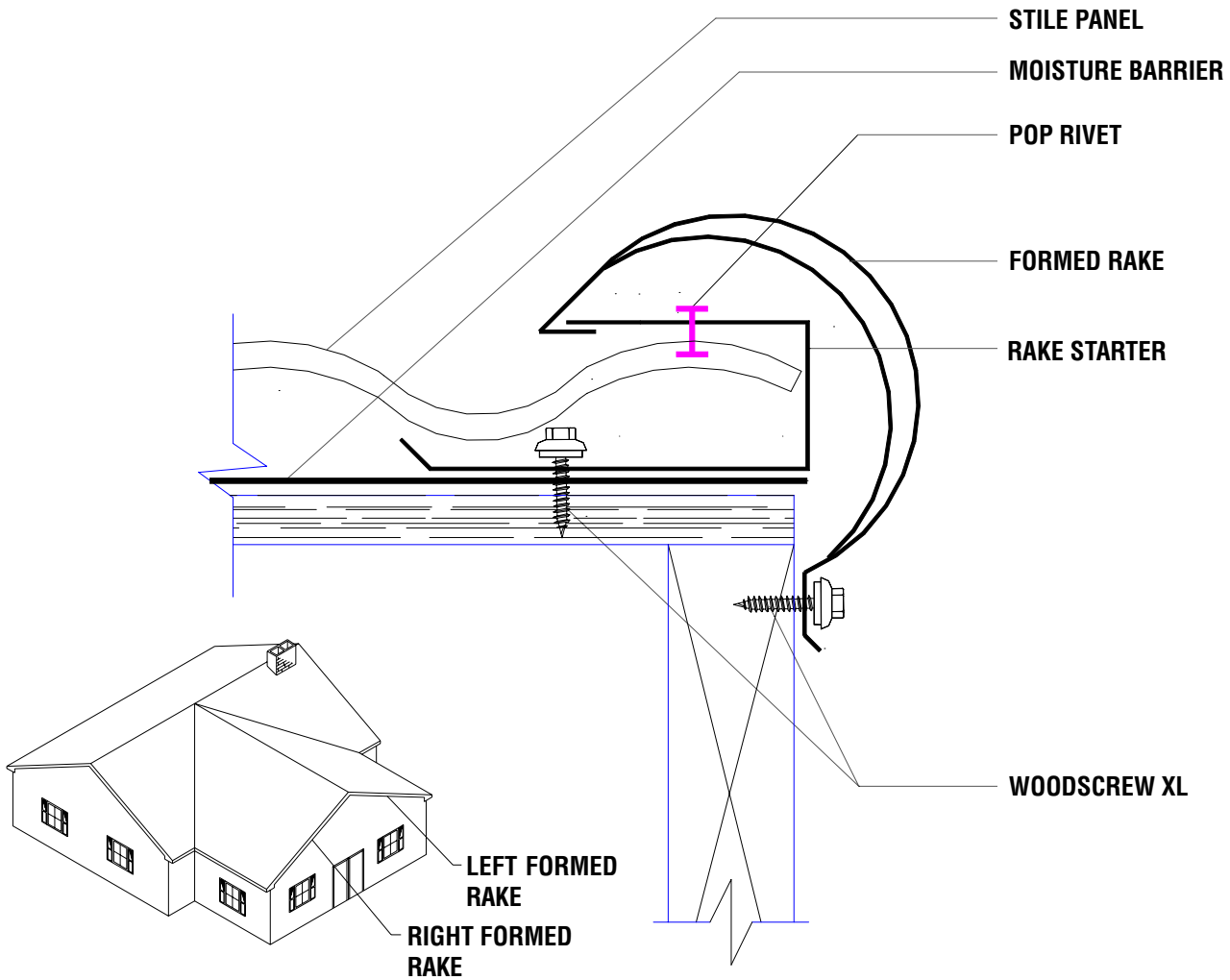

**FLASHING PROFILES**

**ACCESSORIES**

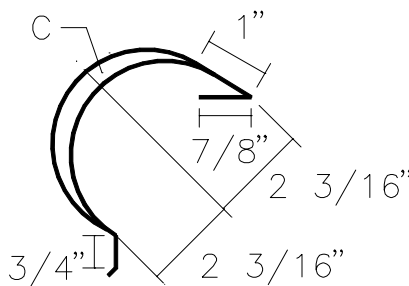

**FORMED RAKE**

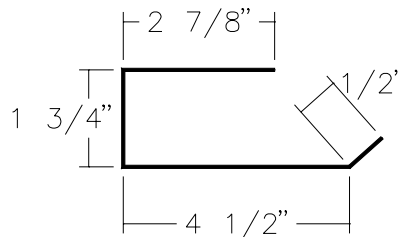

**RAKE STARTER**

- **TUBE SEALANT**
- **STITCH SCREW XL (1'-0" O.C. TYPICAL)**
- **WOODSCREW XL (1'-0" O.C. TYPICAL)**

# STILE RAKE DETAIL

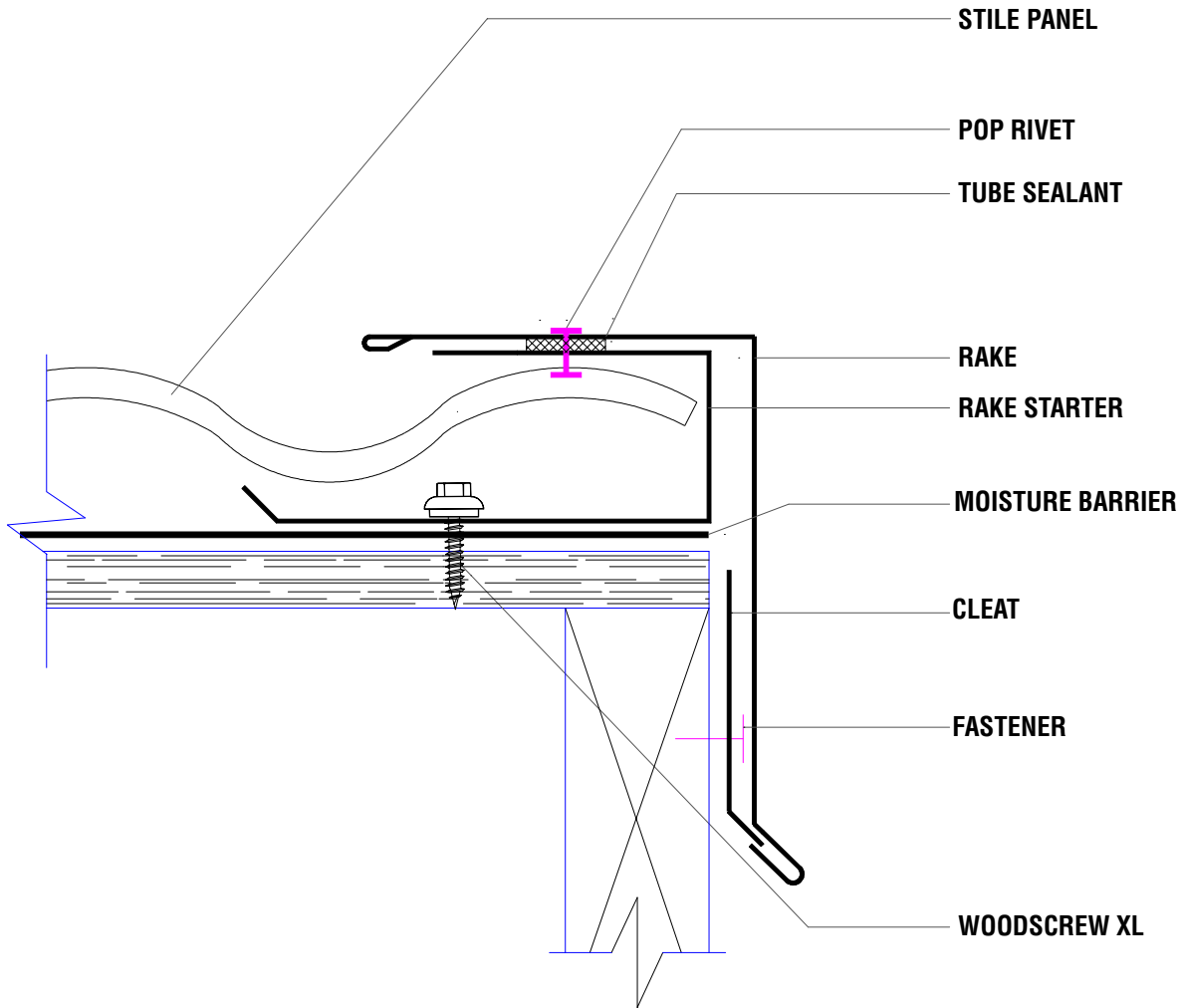

## FLASHING PROFILES

## ACCESSORIES

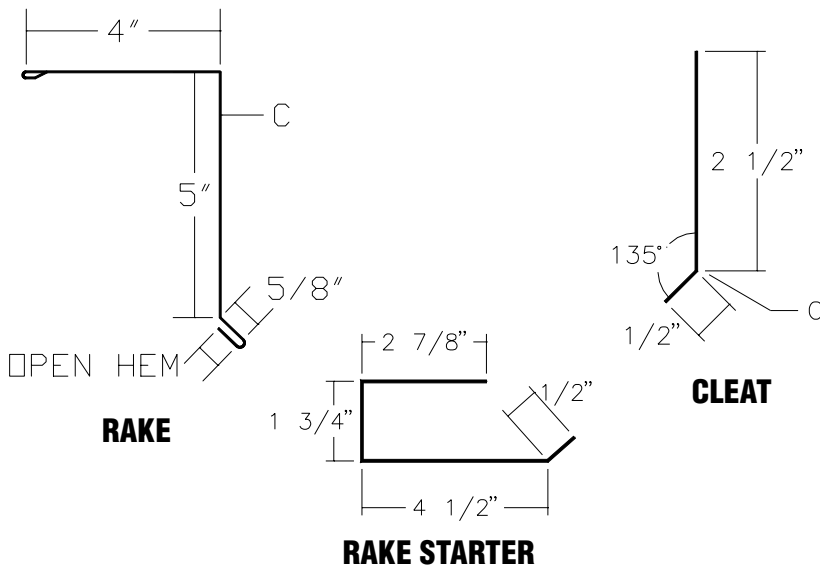

- TUBE SEALANT
- POP RIVETS  
(1'-0" O.C. TYPICAL)
- WOODSCREW XL  
(1'-0" O.C. TYPICAL)



# STILE EAVE DETAIL

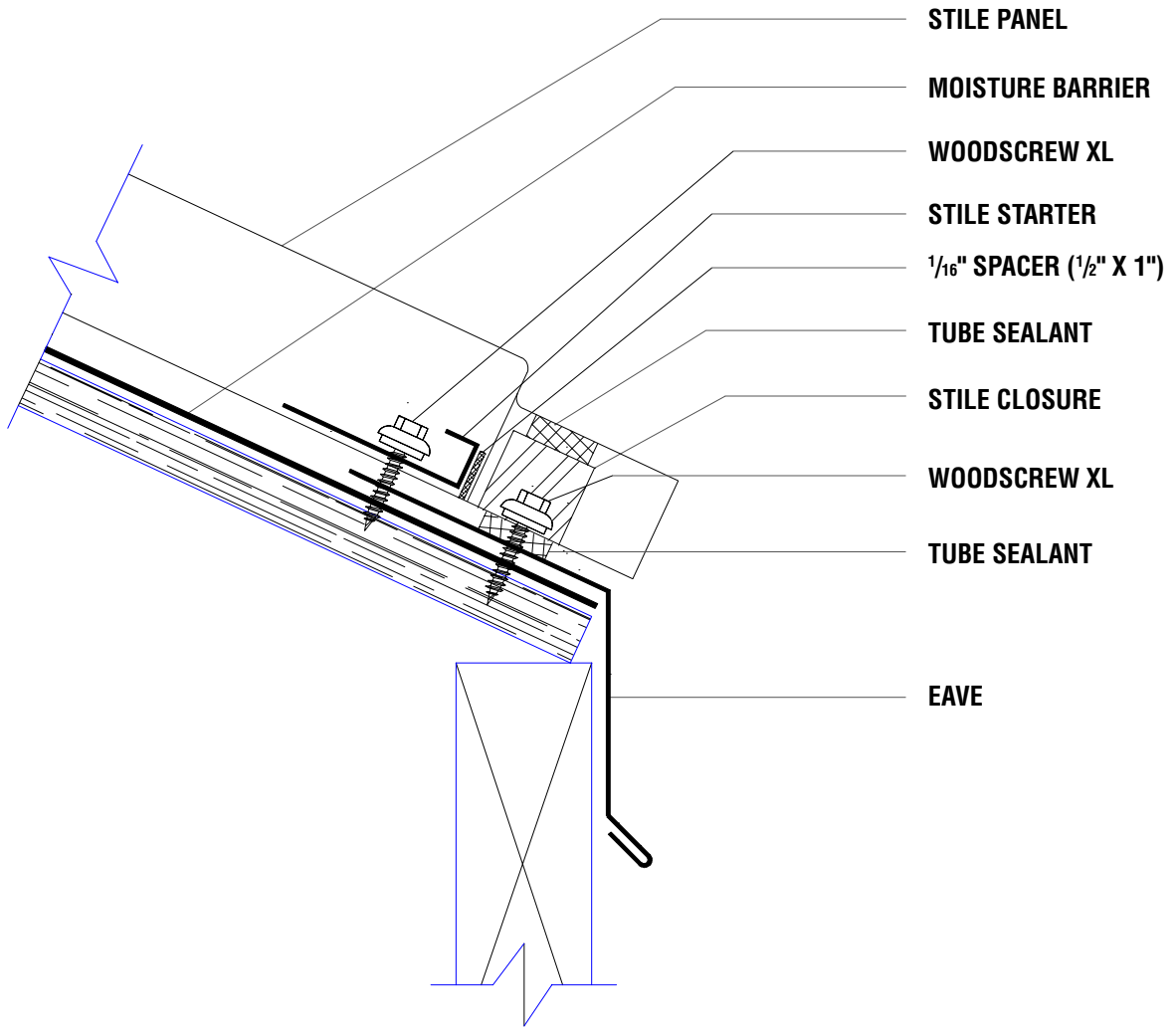

## FLASHING PROFILES

## ACCESSORIES

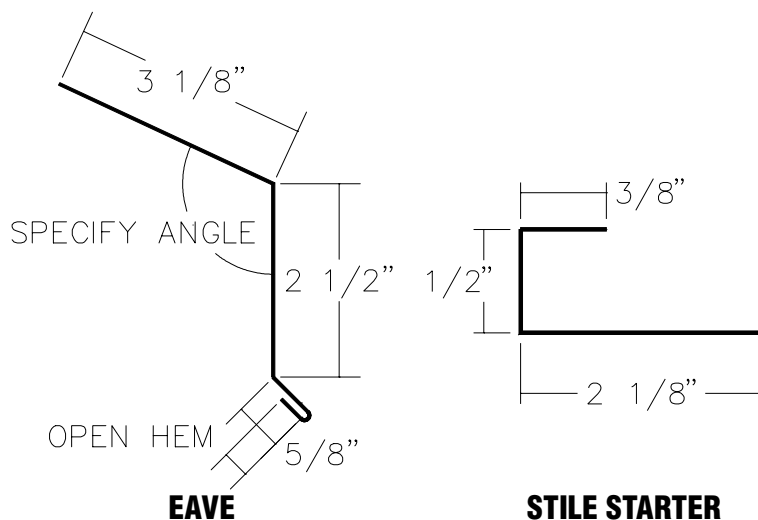

- **STILE CLOSURE**
- **TUBE SEALANT**
- **POP RIVETS**  
(1'-0" O.C. TYPICAL)
- **WOODSCREW XL**  
(1'-0" O.C. TYPICAL)

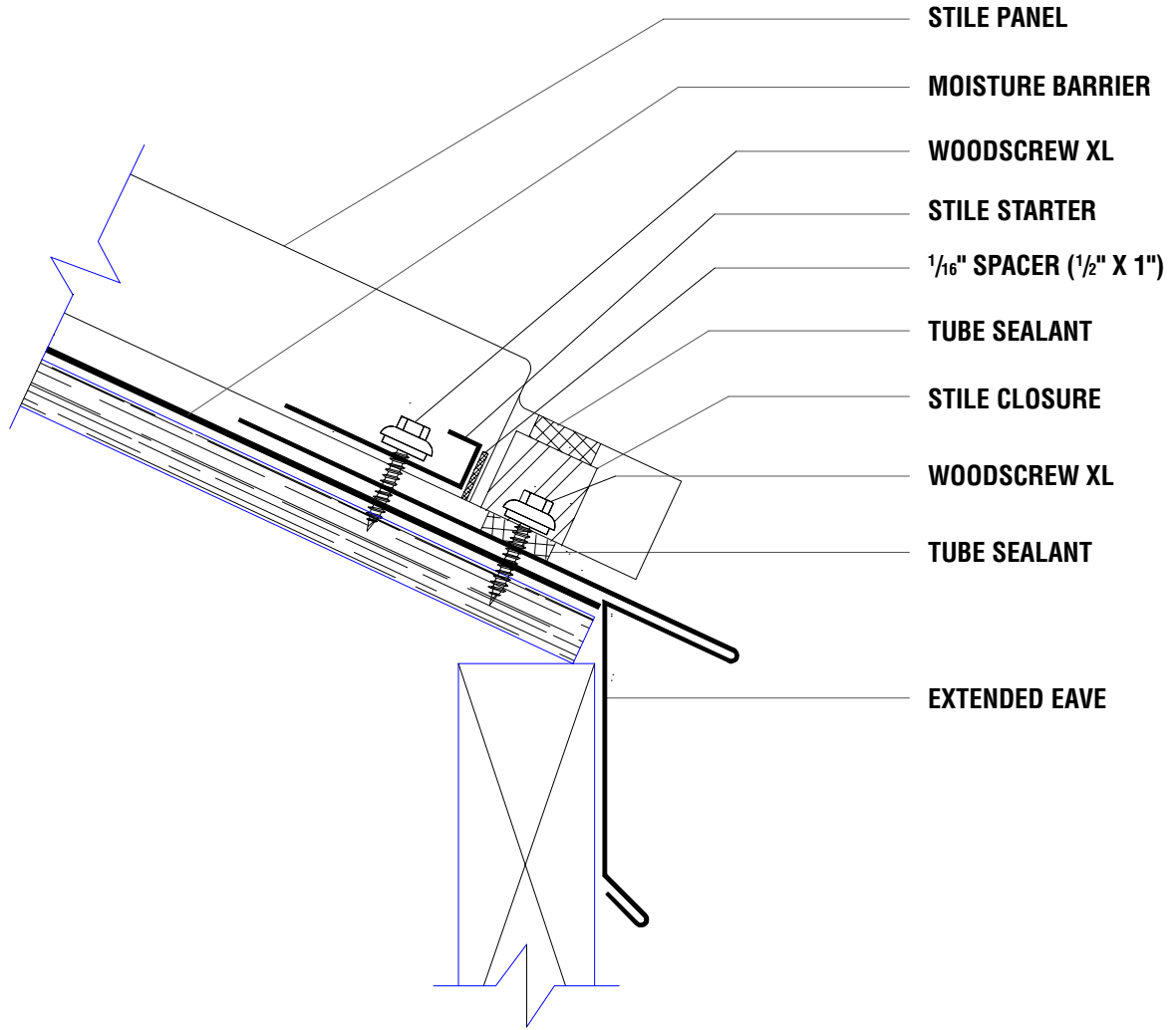

**FLASHING PROFILES**

**ACCESSORIES**

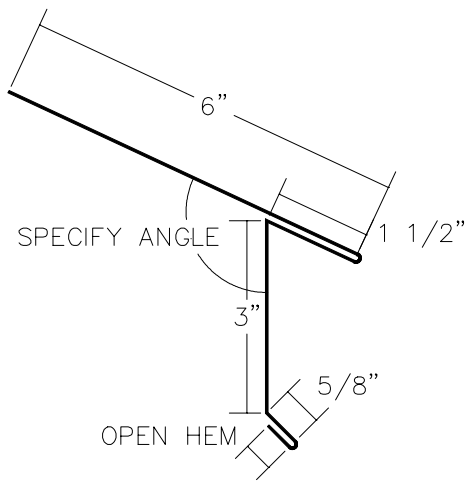

**EXTENDED EAVE**

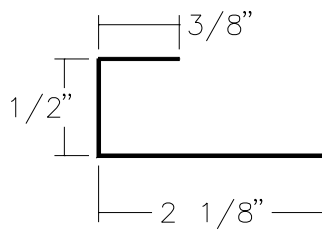

**STILE STARTER**

- **STILE CLOSURE**
- **TUBE SEALANT**
- **POP RIVETS**  
(1'-0" O.C. TYPICAL)
- **WOODSCREW XL**  
(1'-0" O.C. TYPICAL)

# STILE GUTTER DETAIL

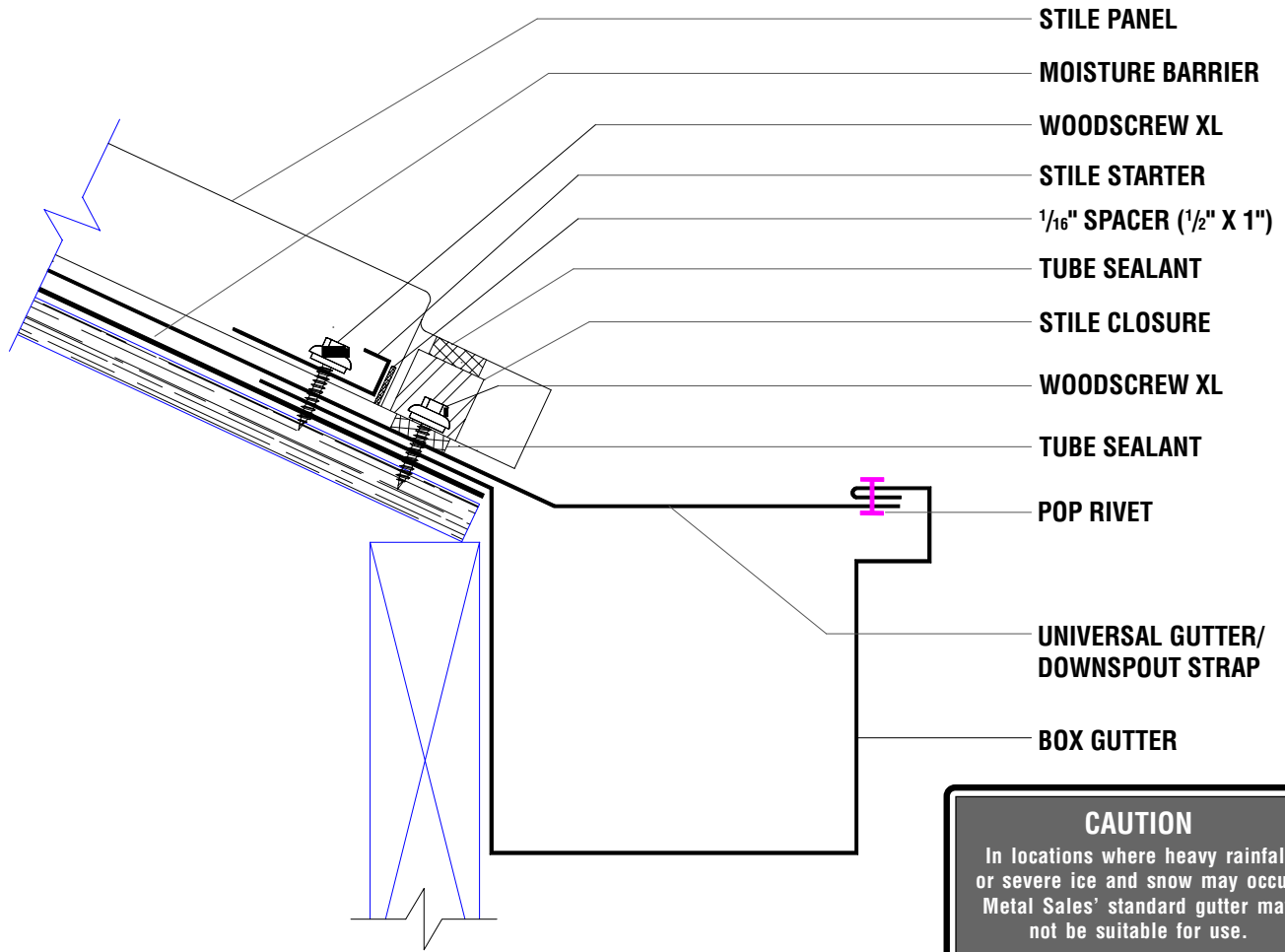

**CAUTION**  
 In locations where heavy rainfall  
 or severe ice and snow may occur,  
 Metal Sales' standard gutter may  
 not be suitable for use.

## FLASHING PROFILES

## ACCESSORIES

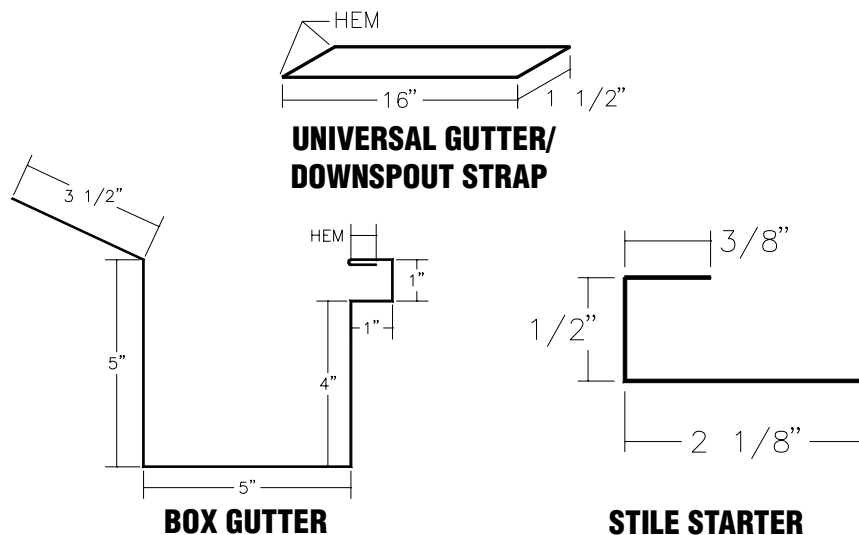

- **STILE CLOSURE**
- **TUBE SEALANT**
- **POP RIVETS**  
(1'-0" O.C. TYPICAL)
- **WOODSCREW XL**  
(1'-0" O.C. TYPICAL)

# STILE RAKE PARAPET COUNTER DETAIL

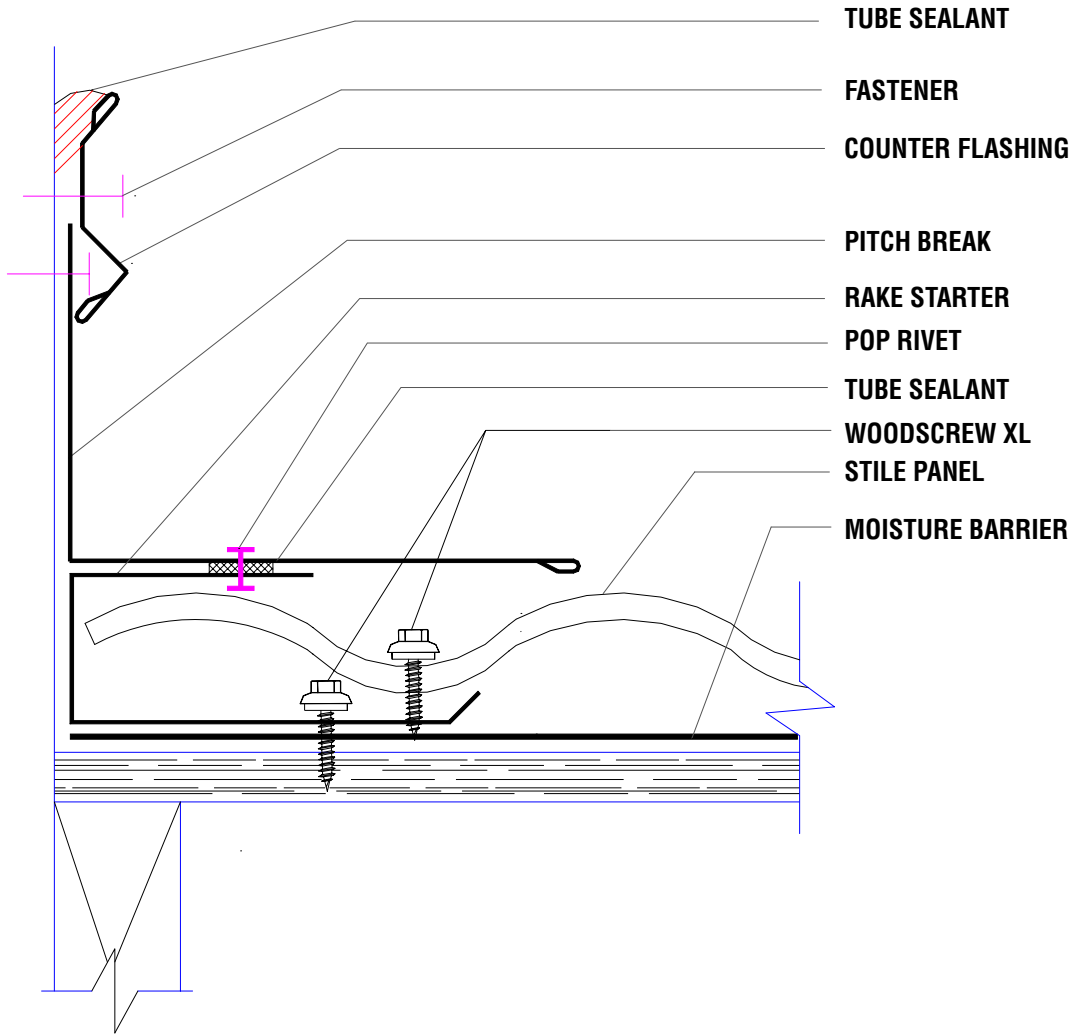

## FLASHING PROFILES

## ACCESSORIES

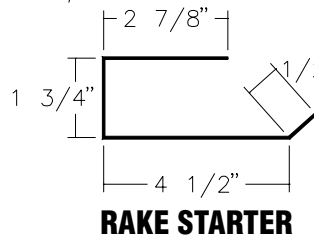
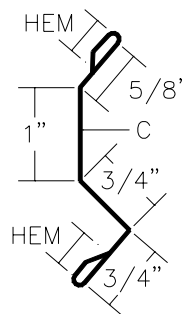
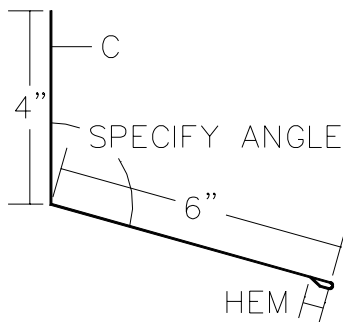

- **TUBE SEALANT**
- **POP RIVETS**  
(1'-0" O.C. TYPICAL)
- **WOODSCREW XL**  
(1'-0" O.C. TYPICAL)

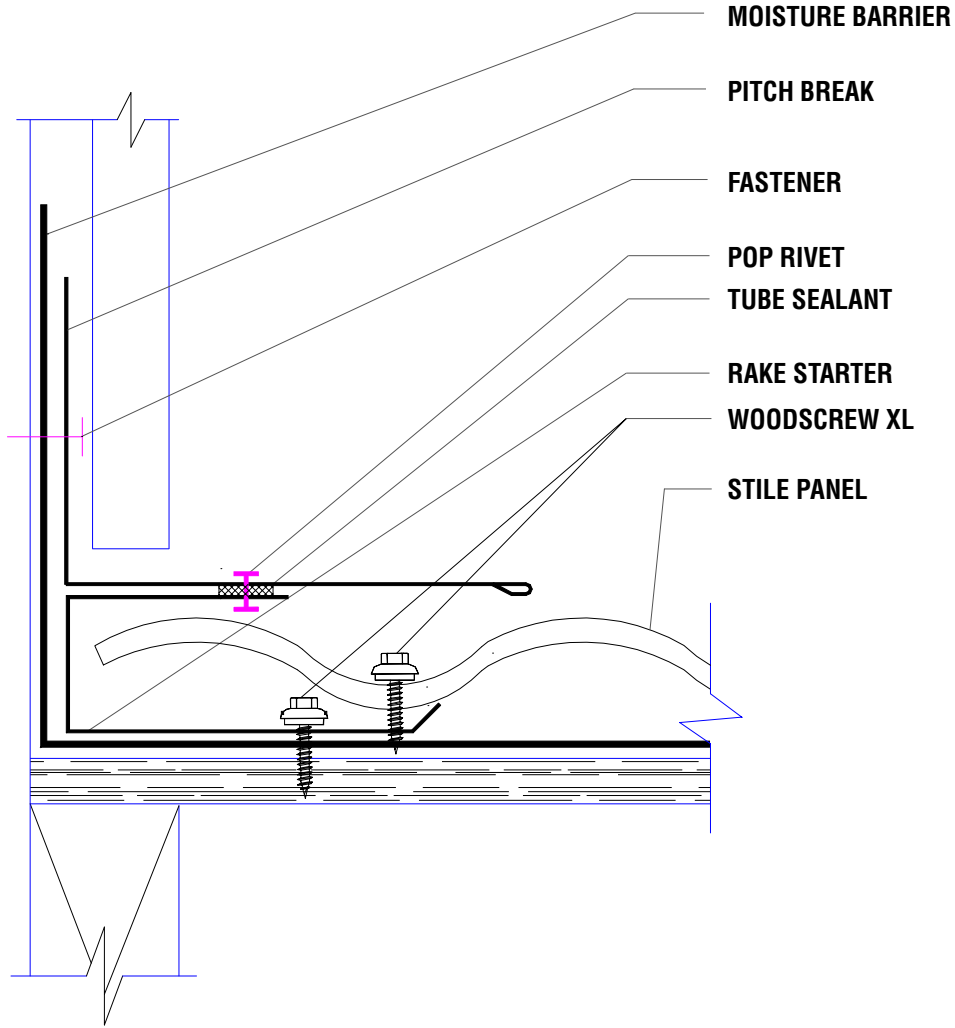

**FLASHING PROFILES**

**ACCESSORIES**

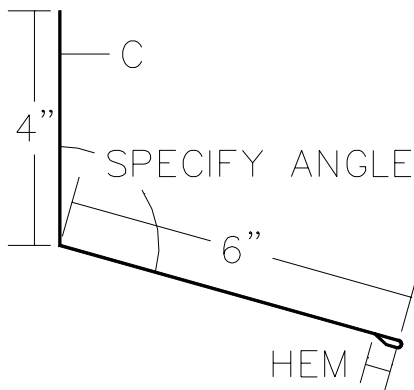

**PITCH BREAK**

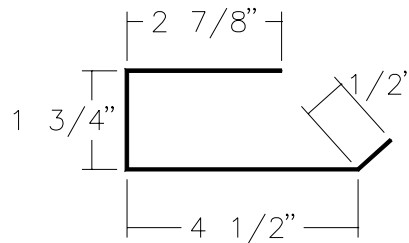

**RAKE STARTER**

- **TUBE SEALANT**
- **POP RIVETS**  
(1'-0" O.C. TYPICAL)
- **WOODSCREW XL**  
(1'-0" O.C. TYPICAL)

# STILE HIGH SIDE COUNTER DETAIL

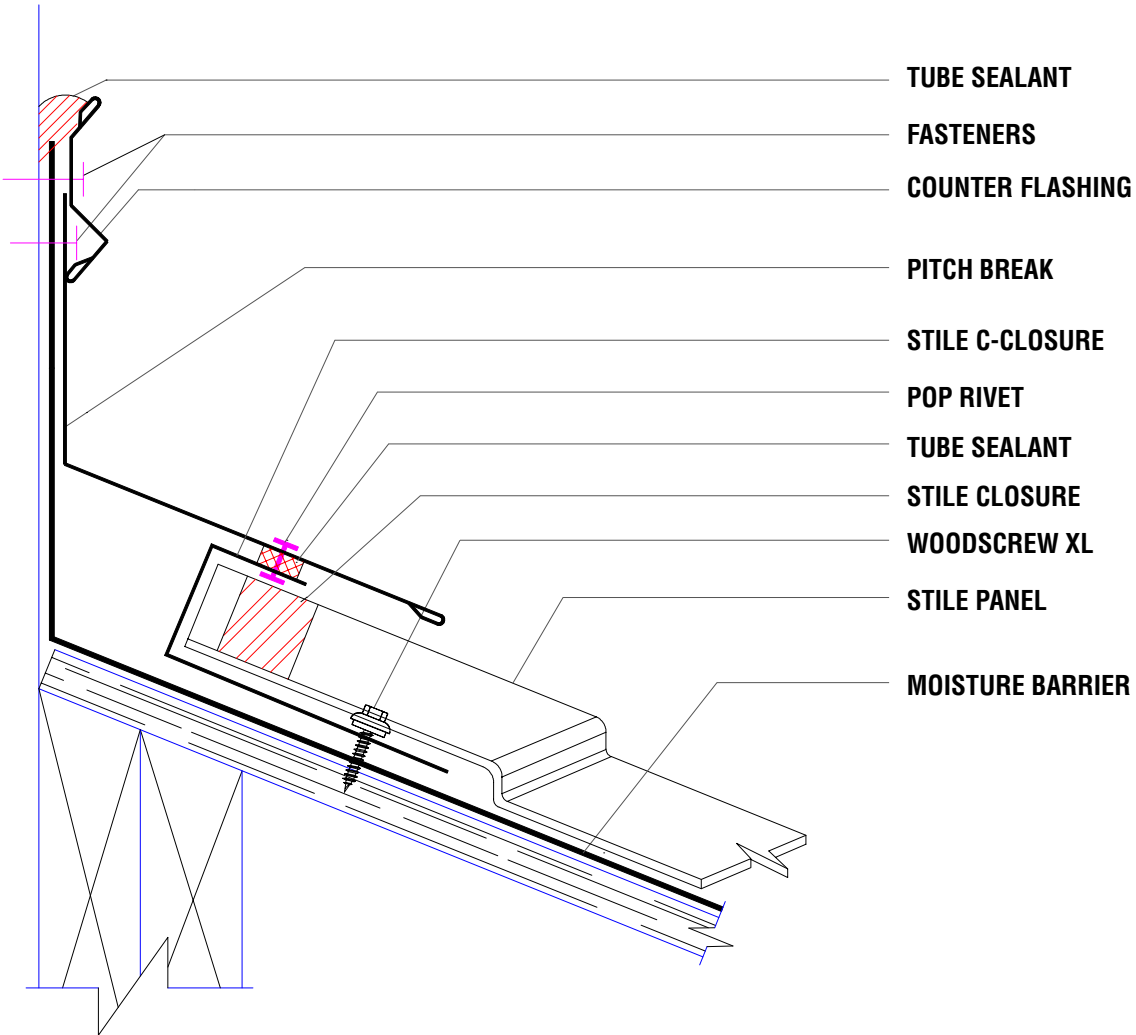

## FLASHING PROFILES

## ACCESSORIES

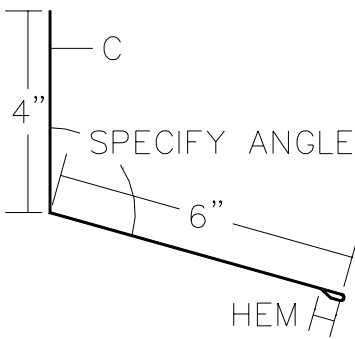

**PITCH BREAK**

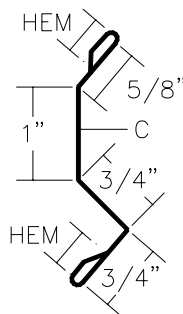

**COUNTER FLASHING**

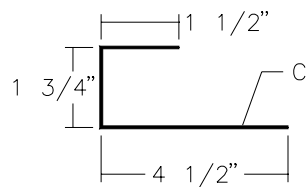

**STILE C-CLOSURE**

- **STILE CLOSURE**
- **TUBE SEALANT**
- **POP RIVETS**  
(1'-0" O.C. TYPICAL)
- **WOODSCREW XL**  
(1'-0" O.C. TYPICAL)

# STILE HIGH SIDE REGLET DETAIL

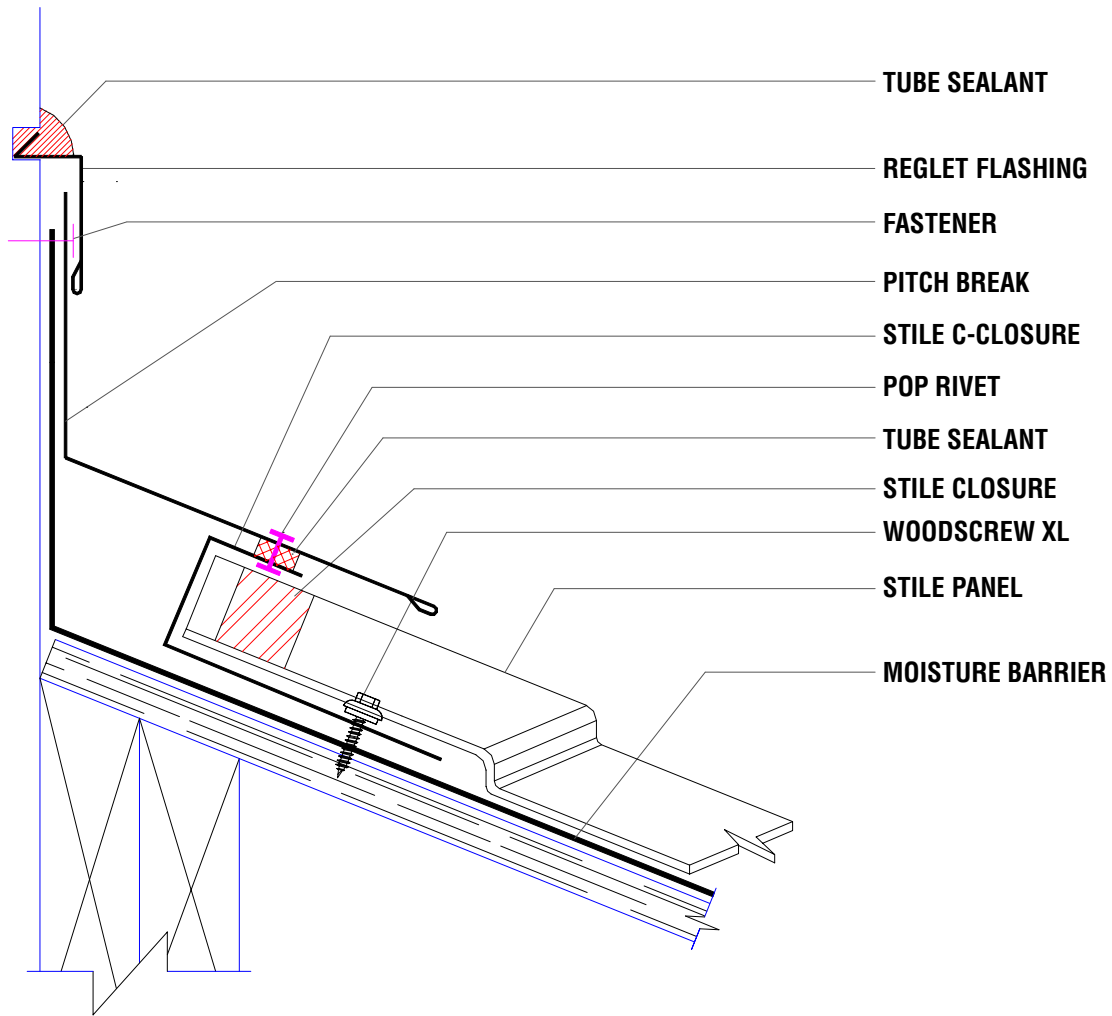

## FLASHING PROFILES

## ACCESSORIES

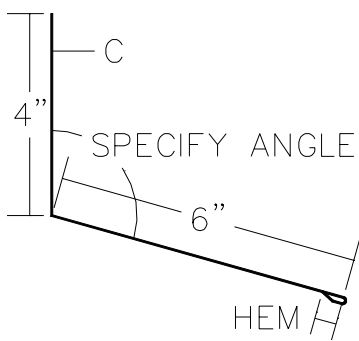

**PITCH BREAK**

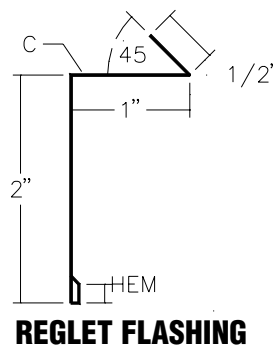

**REGLET FLASHING**

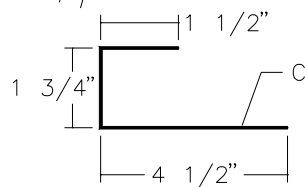

**STILE C-CLOSURE**

- **STILE CLOSURE**
- **TUBE SEALANT**
- **POP RIVETS**  
(1'-0" O.C. TYPICAL)
- **WOODSCREW XL**  
(1'-0" O.C. TYPICAL)

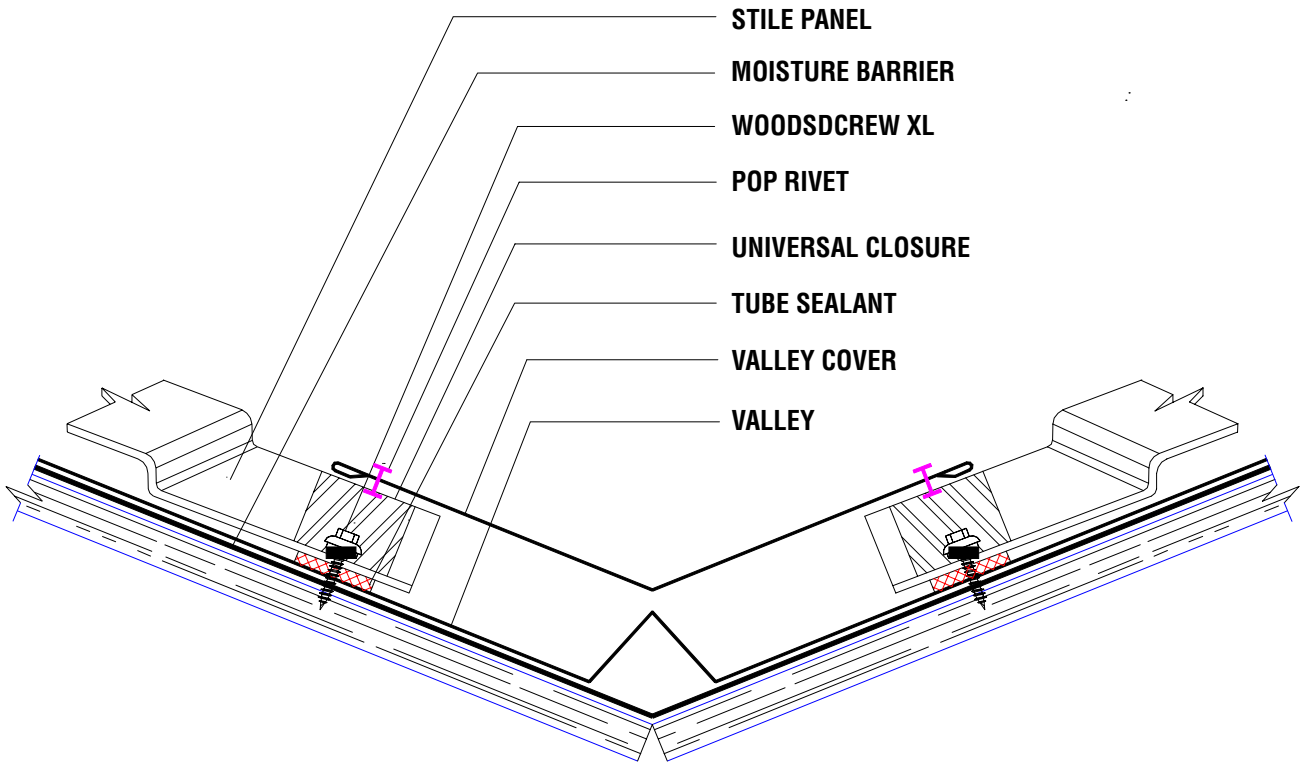

**FLASHING PROFILES**

**ACCESSORIES**

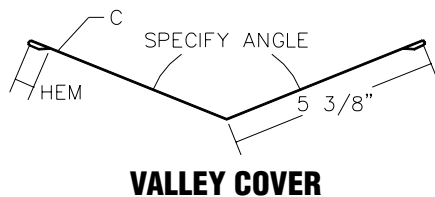
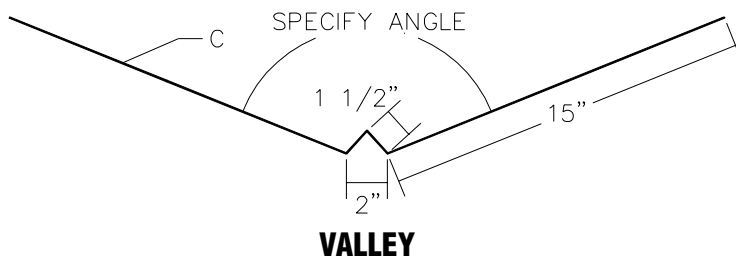

- **UNIVERSAL CLOSURE**
- **TUBE SEALANT**
- **POP RIVETS**  
(1'-0" O.C. TYPICAL)
- **WOODSCREW XL**  
(1'-0" O.C. TYPICAL)



# STILE HIGH SIDE PARAPET DETAIL

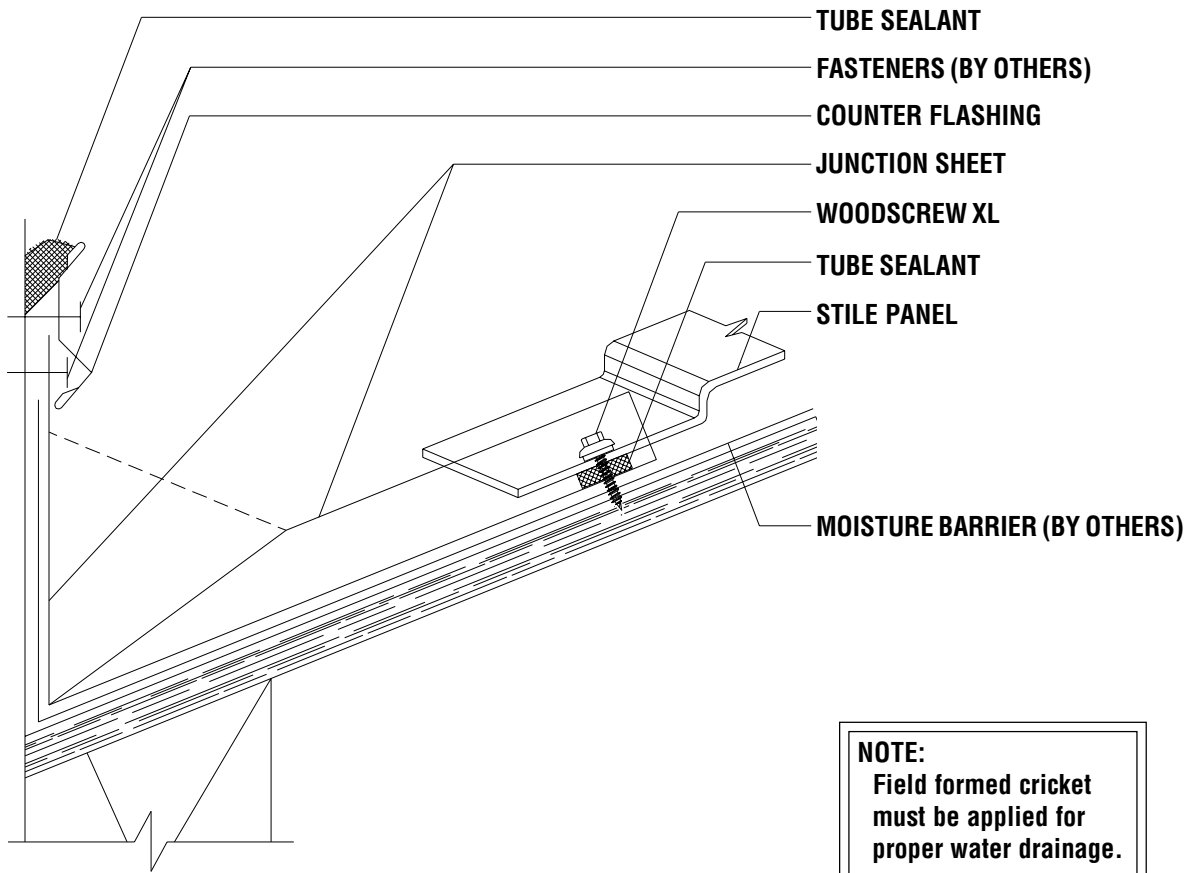

## FLASHING PROFILES

## ACCESSORIES

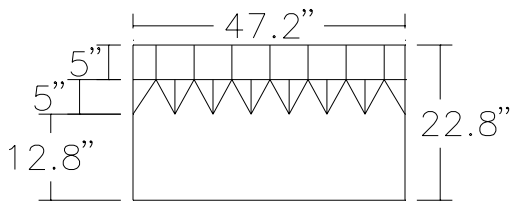

**JUNCTION SHEET**

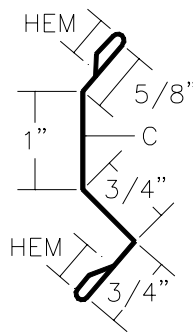

**COUNTER FLASHING**

- TUBE SEALANT
- WOODSCREW XL  
(1'-0" O.C. TYPICAL)

# STILE SLOPE CHANGE DETAIL

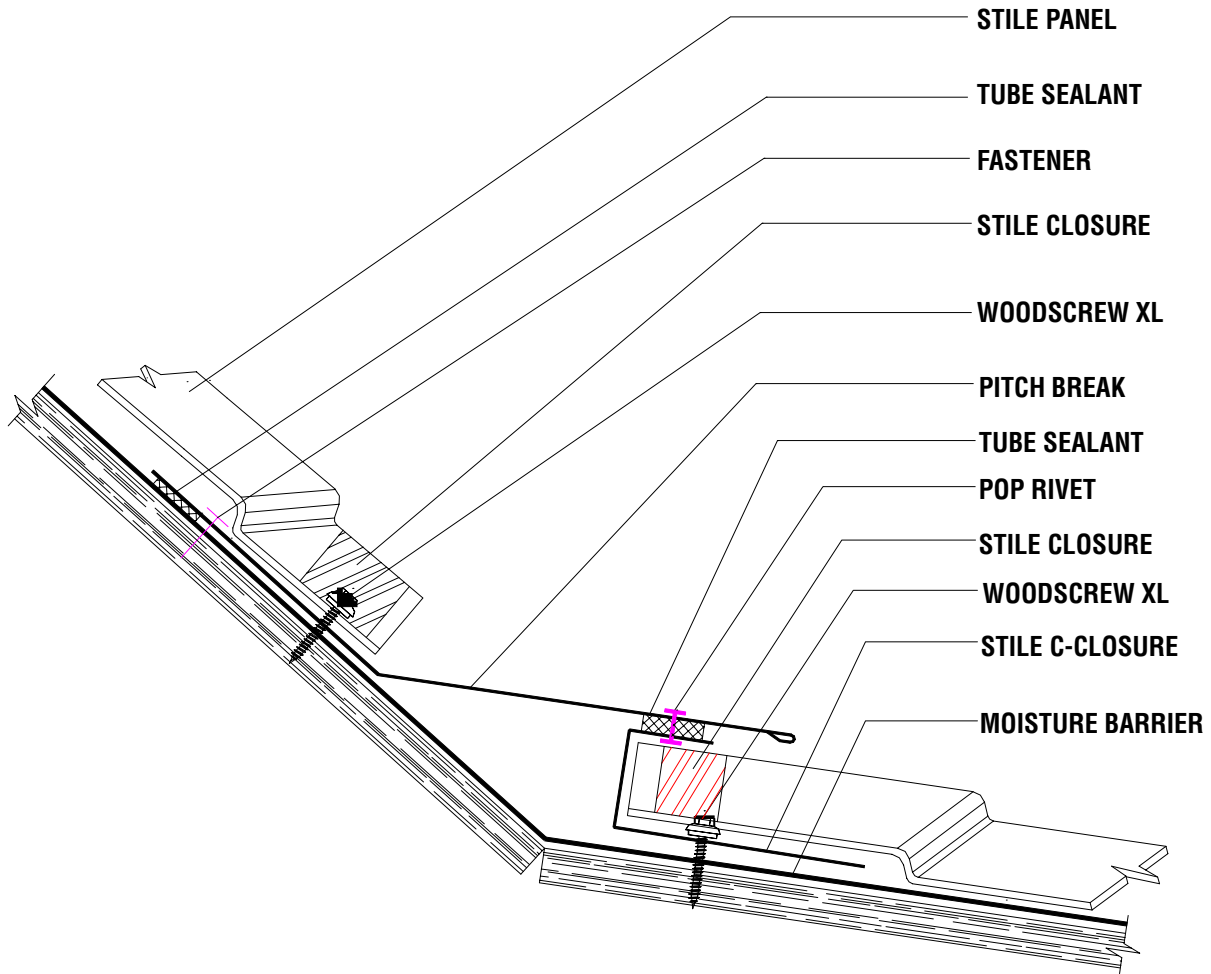

## FLASHING PROFILES

## ACCESSORIES

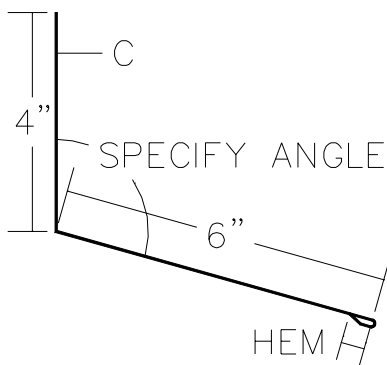

**PITCH BREAK**

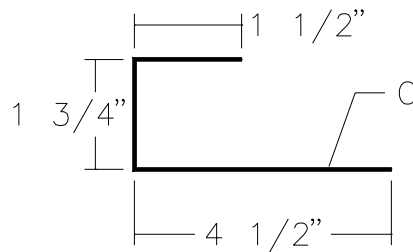

**STILE C-CLOSURE**

- **STILE CLOSURE**
- **TUBE SEALANT**
- **POP RIVETS**  
(1'-0" O.C. TYPICAL)
- **WOODSCREW XL**  
(1'-0" O.C. TYPICAL)

# STILE STILE ROOF VENT DETAIL

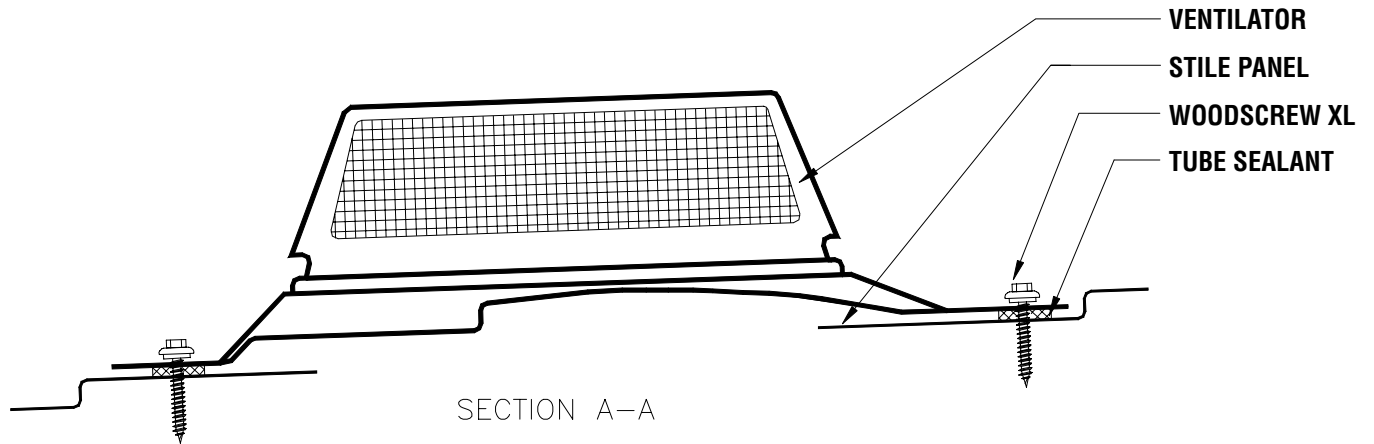
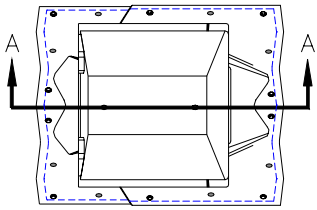

## FLASHING PROFILES

## ACCESSORIES

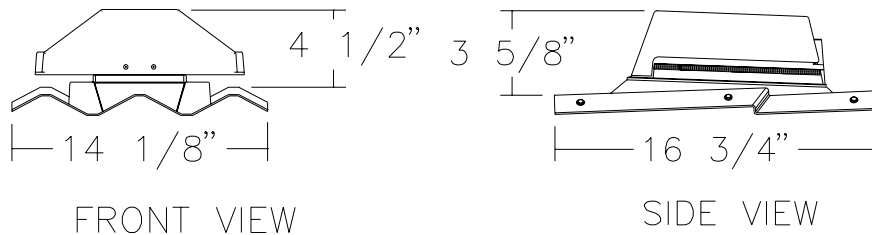

- TUBE SEALANT
- WOODSCREW XL  
(1'-0" O.C. TYPICAL)

### STILE ROOF VENT

Though factory applied prepainted finishes are very durable and will last many years, eventually it may be desirable to thoroughly clean or repaint them.

Dirt pickup may cause apparent discoloration of the paint when it has been exposed in some dirt laded atmospheres for long periods of time. In areas of strong sunlight, slight chalking may cause some change in appearance. A good cleaning will often restore the appearance of these buildings and render repainting unnecessary. An occasional light cleaning will help maintain a good appearance.

In many cases, simply washing the building with plain water using a hose or pressure sprayer will be adequate. In areas where heavy dirt deposits dull the surface, a cloth or soft bristle brush and solution of water and detergent ( $\frac{1}{3}$  cup of Tide per gallon of water for example) may be used. This should be followed by an adequate rinse of water. Do not use wire brushes, abrasives, or cleaning tools which will abrade the coating surface.

Mildew may occur in areas subject to high humidity but is not normally a problem due to the high inherent mildew resistance of the baked finish that is used. However, mildew can grow on dirt and spore deposits in some cases. To remove mildew along with the dirt, the following solution is recommended.

- $\frac{1}{3}$  cup detergent (Tide or equivalent)
- $\frac{2}{3}$  cup trisodium phosphate (Solex or equivalent)
- 1 quart of 5% sodium hypochlorite solution (Clorox or equivalent)
- 3 quarts of water

Strong solvents and abrasive type cleaners should be avoided. Most organic solvents are flammable and toxic and must be handled accordingly. When using a solvent, consult maintenance professionals and label instructions for proper handling and disposal of washings. If required, a mild solvent such as mineral spirits can be used to remove caulking compounds, oil, grease, tars, wax, and similar substances. Use a cloth dampened with mineral spirits and apply only to areas which are contaminated. Follow up the use of this mild solvent with detergent cleaning and rinsing.



**DO NOT USE A  
WIRE BRUSH**

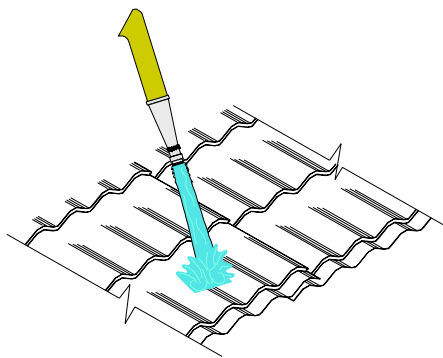

**HOSE OR PRESSURE SPRAY  
FOR ADEQUATE CLEANING**

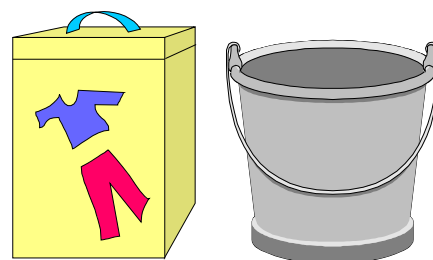

**USE MILD DETERGENT AND WATER  
FOR HEAVY DIRT DEPOSITS**



**Longmont, Colorado**  
800.289.7663

**Jacksonville, Florida**  
800.394.4419

**Jefferson, Ohio**  
800.321.5833

**Independence, Missouri**  
800.747.0012

**Sellersburg, Indiana**  
800.999.7777

**Rogers, Minnesota**  
800.328.9316

**Antioch, Tennessee**  
800.251.8508

**Spokane, Washington**  
800.572.6565

**Kent, Washington**  
800.431.3470

**Rock Island, Illinois**  
800.747.1206

**Orwigsburg, Pennsylvania**  
800.544.2577

**Temple, Texas**  
800.543.4415

**Woodland, California**  
800.759.6019

**Fontana, California**  
800.782.7953

**Anchorage, Alaska**  
907.646.7663

---

**[www.mtlsales.com](http://www.mtlsales.com)**

**metal sales**  
manufacturing corporation

