

<b>Product</b>	<b>Page No.</b>
<b>Panel Information</b>	
5V-Crimp Panel Profile .....	P5V-2
Panel Overview .....	P5V-2
<b>Flashing Profiles</b>	
Eave .....	P5V-3
Cleat .....	P5V-3
Box Gutter .....	P5V-3
Box Gutter End .....	P5V-3
Universal Gutter/Downspout Strap .....	P5V-3
4" x 3 1/2" Downspout .....	P5V-3
4" x 3 1/2" 90° Elbow .....	P5V-3
Downspout Bracket .....	P5V-3
Valley .....	P5V-3
5V-Crimp Rake .....	P5V-3
5V-Crimp Rakewall .....	P5V-3
Counter Flashing .....	P5V-3
Reglet Flashing .....	P5V-3
11" Ridge/Hip Cover .....	P5V-3
Peak .....	P5V-3
Pitch Break .....	P5V-4
5V-Crimp Z-Closure .....	P5V-4
<b>Accessory Profiles</b>	
5V-Crimp Closures .....	P5V-4
Tube Sealant .....	P5V-4
Tape Sealant .....	P5V-4
Rubber Roof Jack .....	P5V-4
Touch-Up Paint .....	P5V-4
<b>Testing Information</b>	
UL 580 Wind Uplift Information .....	P5V-5
Section Properties and General Information .....	P5V-6
<b>Design/Installation Considerations</b>	
Fastener Installation Technique .....	P5V-7
Condition of Substructure .....	P5V-7
Ventilation .....	P5V-8
Panel Applications .....	P5V-8

<b>Product</b>	<b>Page No.</b>
<b>Detail Conditions</b>	
Eave Detail .....	P5V-9
Box Gutter Detail .....	P5V-9
Valley Detail .....	P5V-10
Endlap Detail .....	P5V-10
Rake Detail .....	P5V-11
Rakewall Detail .....	P5V-11
Endwall Detail .....	P5V-12
Peak Detail .....	P5V-12
Hip Detail .....	P5V-13
Ridge Detail .....	P5V-13
<b>Notes</b>	
Notes .....	P5V-14

# 5V-CRIMP PANEL OVERVIEW

## PANEL PROFILE

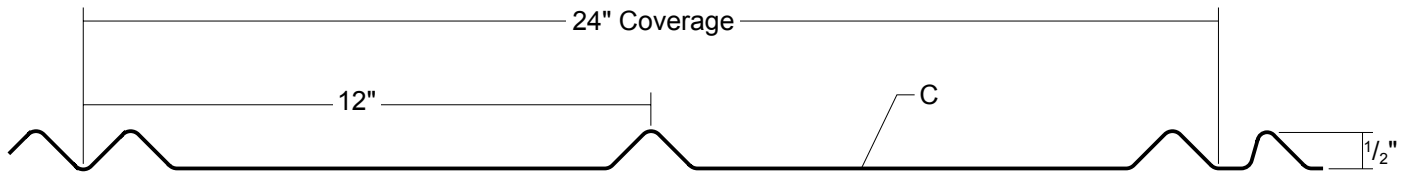

## SLOPE

The minimum recommended slope for any 5V-Crimp roofing panel is 3:12.

## SUBSTRATE

The recommended substrate is  $\frac{5}{8}$ " plywood with a 30 pound felt moisture barrier. To avoid panel distortion, use a properly aligned and uniform substructure. **Please note that 5V-Crimp panels are not recommended for use over open framing.**

## COVERAGE

5V-Crimp is available in 24" width with a  $\frac{1}{2}$ " rib height.

## LENGTH

Lengths under 5'-0" are available with some cutting restrictions. Maximum recommended panel length is 45'-0". Longer panels require additional consideration in packaging, shipping, and erection. Please consult your Metal Sales branch for recommendations (see PGI-2 and 3 for locations).

## AVAILABILITY

26 Gauge

## APPLICATION

Architectural and Residential panel.

## PERFORMANCE TEST

UL 580, UL 790, UL 263, UL 2218, Miami-Dade County

## FASTENING SYSTEM

Direct fastened (exposed).

## FASTENERS

The fastener selection guide should be consulted for choosing proper fasteners for specific applications. Quantity and type of fastener must meet necessary loading and code requirements (see PGI-12-14).

## MATERIALS

Steel grade 50, per ASTM A-792

## FINISH

- ▶ \*Acrylic Coated Galvalume® (ACG) / ASTM A-792 - AZ55
- ▶ Prepainted Galvalume / ASTM A-792 - AZ50
- ▶ \*\*Fluorocarbon (PVDF)

\* Differential appearance of Acrylic Coated Galvalume roofing materials is not a cause for rejection.

\*\* Meets both Kynar 500 and Hylar 5000 specifications.

**EAVE**

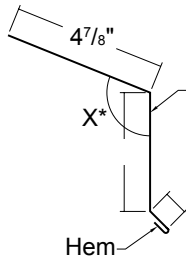

Length 10'-2" - \*Specify Slope Angle

**CLEAT**

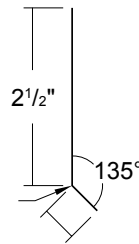

Length 10'-2"

**BOX GUTTER**

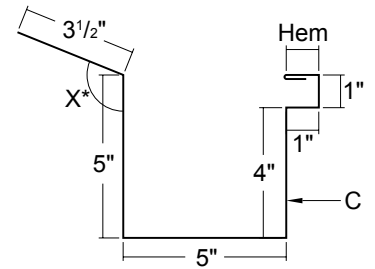

Length 10'-2", 20'-3" - \*Specify Slope Angle

**BOX GUTTER END**

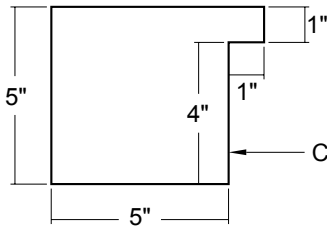

**UNIVERSAL GUTTER/ DOWNSPOUT STRAP**

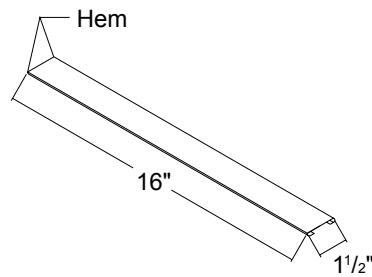

**DOWNSPOUT 4\" x 3 1/2\"**

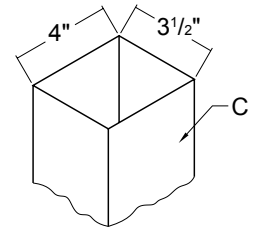

Length 10'-2", 20'-3" (Also available 6\" x 4")

**95° ELBOW 4\" x 3 1/2\"**

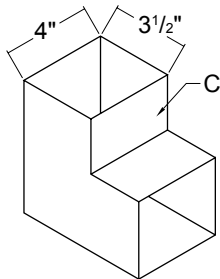

(Also available 6\" x 4")

**DOWNSPOUT BRACKET**

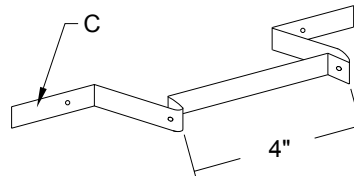

(Also available 6")

**VALLEY**

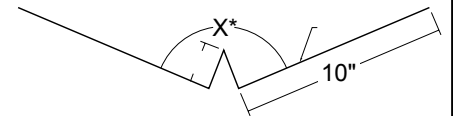

Length 10'-2", 20'-3" - \*Specify Slope Angle

**5V-CRIMP RAKE**

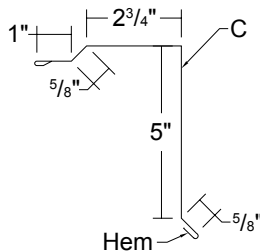

Length 10'-2", 20'-3"

**5V-CRIMP RAKEWALL**

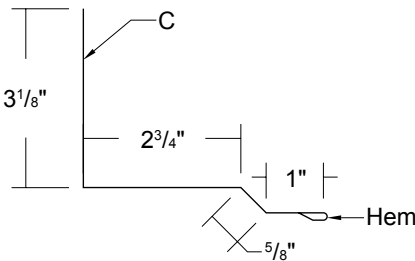

Length 10'-2"

**COUNTER FLASHING**

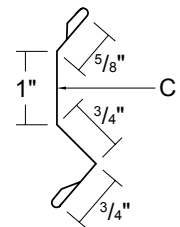

Length 10'-2"

**REGLET FLASHING**

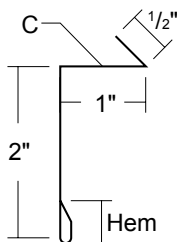

Length 10'-2"

**11\" RIDGE/HIP COVER**

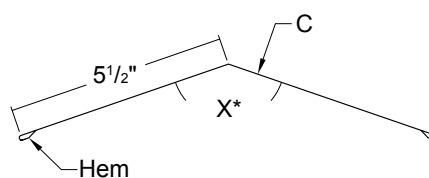

Length 10'-2", 20'-3" - \*Specify Slope Angle

**PEAK**

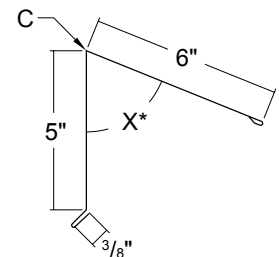

Length 10'-2", 20'-3" - \*Specify Slope Angle

# 5V-CRIMP FLASHING PROFILES (CONT.) / ACCESSORY PROFILES

## PITCH BREAK

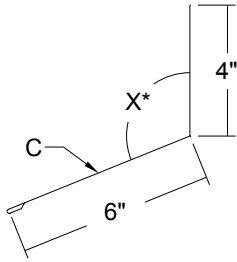

Length 10'-2" - \*Specify Slope Angle

## 5V-CRIMP Z-CLOSURE

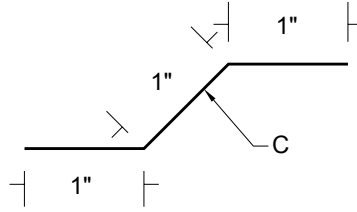

Length 10'-2"

C- Indicates color side of flashing.

# 5V-CRIMP ACCESSORY PROFILES

## 5V-CRIMP CLOSURES

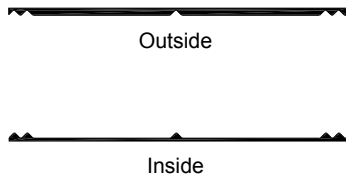

1" x 2'-0" Polyethylene Foam

## TUBE SEALANT

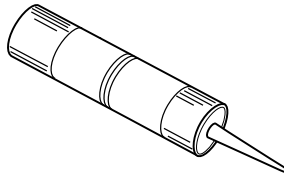

10.3 oz. Cartridge Urethane

## TAPE SEALANT



<sup>3</sup>/<sub>8</sub>" Bead x 50' Butyl Single Bead Sealant Butyl - Black

## RUBBER ROOF JACK

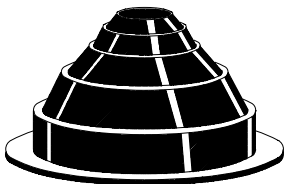

MINI (1/4" to 1 1/8" O.D. Pipe)  
 #2 (1 3/4" to 3" O.D. Pipe)  
 #4 (3" to 6" O.D. Pipe)  
 #6 (6" to 9" O.D. Pipe)  
 #8 (7" to 13" O.D. Pipe)

## TOUCH-UP PAINT

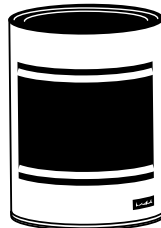

Available in pints  
 PVDF / MS Colorfast45

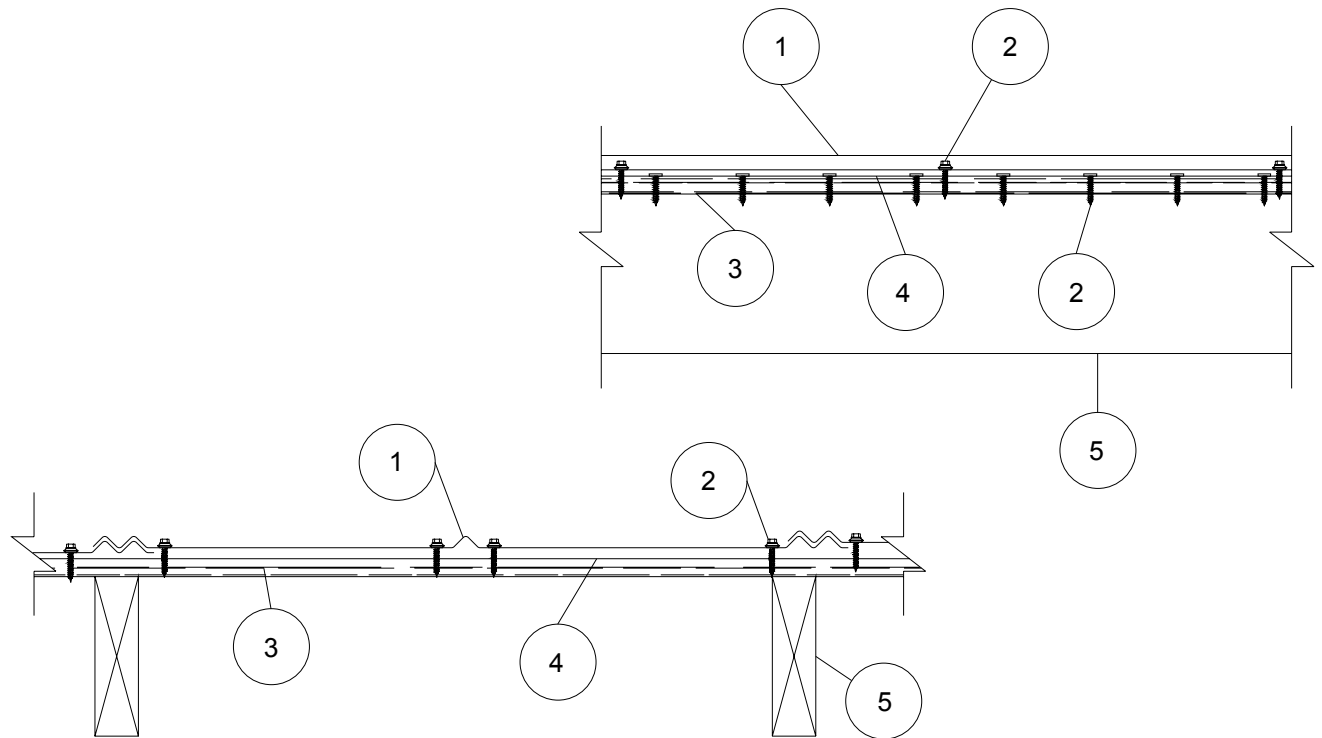
**5V-CRIMP****Construction No. 453**

March 13, 2001

Uplift - Class 90

Fire Not Investigated

1. Metal Roof Deck Panels\* No. 26 MSG minimum coated steel. Maximum panel width 24 in. Rib height maximum 1/2 in. Panels continuous over two or more spans. A bead of sealant may be used at panel sidelaps.  
METAL SALES MFG CORP - "5V Crimp"
2. Fasteners - (Screws) For panel attachment to wood deck (Item 3), fasteners to be #9-15 x 1 in. Type A, Hex-head with separate 5/8 in. OD steel washer and a bonded neoprene washer. Fastener spacing is as follows: a line of fasteners is to be installed, beginning from the center of the double V at the sidlap in 2-9-2-9 in. pattern for a total of four fasteners across the width of the panel. This fastener spacing to be 3 feet on center along the length of the panel is 3 feet on center.  
For attachment of plywood deck (Item 3) to joists (Item 5), fasteners to be minimum No. 6 x 1-7/8 in. bugle head screw or annular ring-shank nails. Spacing to be 6 in. OC at plywood edges and 12 in. OC at intermediate supports.  
When light gauge structural steel joists are used, fasteners to be No. 12 x 1-5/8 in. long with a Phillips head.
3. Substructure - (Plywood) Plywood decking to be a nom 5/8 in. thick, exposure sheathing span C-D, 40/20 plywood. All butt joints to be sealed against leakage by using tape and/or caulk or with one-part urethane sealant.
4. Moisture Barrier (Optional) Any suitable membrane to protect substructure (Item 3).
5. Joists Joists spaced at 2 ft , 0 in. OC; may be one of the following:
  - A. Nom 2 by 6 in. wood joists No. 2 or better.
  - B. Nom 2 by 4 in. wood when used on a top cord of a wood truss, No. 2 or better.
  - C. Light gauge structural steel framing with the member against the plywood to be a minimum No. 22 MSG coated steel.

Refer to General Information, Roof Deck Construction, (Roofing Materials and Systems Directory) for Items Not Evaluated.

\*Bearing the UL Classification Mark



Underwriters Laboratories Inc. ®

LISTED

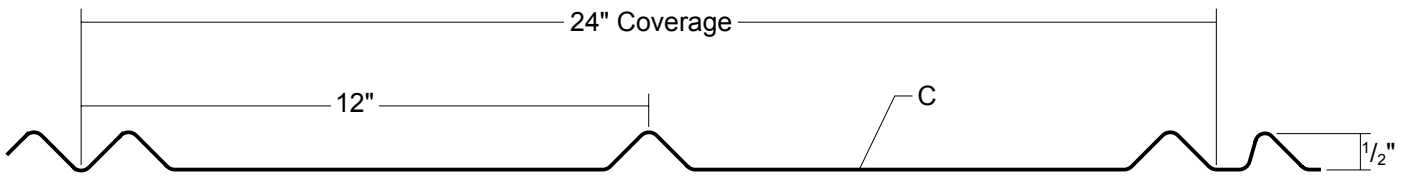

SECTION PROPERTIES								ALLOWABLE UNIFORM LOADS PSF (3 or More Equal Spans)					
Ga.	Width (in.)	Yield KSI	Weight PSF	Top in Compression		Bottom in Compression		Outward Uplift Load					
				Ixx In <sup>4</sup> /ft	Sxx In <sup>3</sup> /ft	Ixx In <sup>4</sup> /ft	Sxx In <sup>3</sup> /ft	0'-6"	1'-0"	1'-6"	2'-0"	2'-6"	3'-0"
26	24"	50	0.77	0.0025	0.0069	0.0015	0.0054	101	89	60	34	22	15
24	24"	50	1.02	0.0030	0.0089	0.0020	0.0073	101	89	60	34	22	15

- Theoretical section properties have been calculated per AISI 2001. "Specifications for the Design of Cold-formed Steel Structural Members." Ixx and Sxx are effective section properties for deflection and bending.
- Allowable load is calculated in accordance with AISI 2001 specifications considering bending, shear, combined bending and shear and deflection. Allowable load considers both 3 or more equal span conditions. Allowable load does not address web crippling or fasteners/support connection. Panel weight is not considered.
- Deflection consideration is limited by a maximum deflection ratio of L/180 of span.
- Allowable loads do not include a 1/3 stress increase in uplift.

**ATTACHMENT DETAIL**

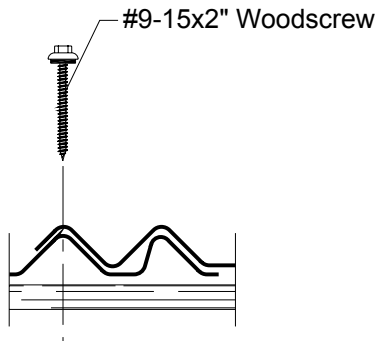

**FASTENING PATTERNS**

**Field of Panel**

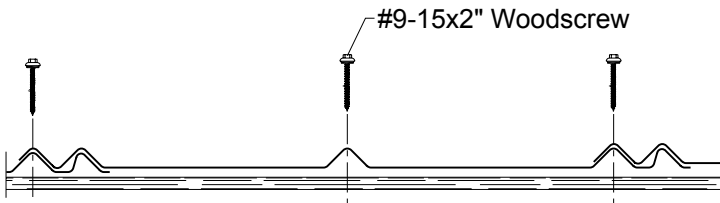

**Ends of Panel**

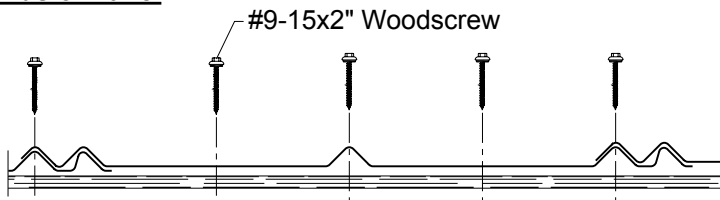

**GENERAL INFORMATION**

► **Slope**

The minimum recommended slope for 5V-Crimp roofing panel is 3:12.

► **Substructure**

The recommended substrate is 5/8" plywood with a 30 pound felt moisture barrier. To avoid panel distortion use a properly aligned and uniform substructure.

*NOTE: 5V-Crimp roof panels are not recommended for use over open structural framing.*

► **Coverage**

5V-Crimp panels are available in a 1/2" rib height with a coverage width of 24".

► **Length**

Minimum factory cut length is 5'-0". Maximum recommended panel length is 45'-0". Longer panels require additional consideration in packaging, shipping, and erection. Please consult Metal Sales for recommendations.

► **Fasteners**

The fastener selection guide should be consulted for choosing the proper fastener for specific applications. Quantity and type of fastener must meet necessary loading and code requirements.

*NOTE: All panels are subject to surface distortion due to improperly applied fasteners. Overdriven fasteners will cause stress and induce oil canning across the face of the panel at or near the point of attachment.*

► **Availability**

*Finishes: Acrylic Coated Galvalume® and MS Colorfast45®*

*Gauges: 26ga and 24ga*

\*Contact Metal Sales Technical Services for Miami-Dade County attachment requirements.

## FASTENER INSTALLATION TECHNIQUE

**Recommended Tool Type** - Use depth locating nose or adjustable clutch on screw gun to prevent overdrilling and strip out. **Do not use impact tools or runners.**

**Seating the washer** - Apply sufficient torque to seat the washer - do not overdrive the fastener.

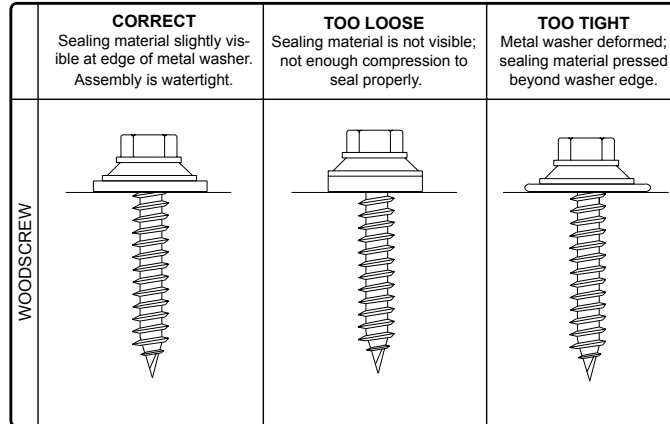

**To prevent wobbling** - Make sure fastener head is completely engaged in the socket. If the head does not go all the way in the socket - tap the magnet deeper into the socket to allow full head engagement. Metal chips will build up from drilling and should be removed from time to time.

**Protect drill point** - Push only hard enough on the screw gun to engage clutch. This prevents excess friction and burn out of the drill point. Correct pressure will allow screw to drill and tap without binding.

**Drilling through sheet and insulation** - Ease up on pressure when drilling through insulation to avoid striking the purlin or girt with the point - apply more pressure after drill point contacts purlin or girt.

**Drilling through purlin overlaps** - Drilling through lapped purlins requires extra care. Excessive voids between purlins sometimes damages drill points and two self-drillers might be necessary to complete the operation. It is sometimes advantageous to predrill.

## CONDITION OF SUBSTRUCTURE

Whether over solid substrate or open structural framing, panel distortion may occur if not applied over properly aligned and uniform substructure.

The installer should check the roof deck for squareness before installing 5V-Crimp panels. Several methods can be used to verify squareness of the structure for proper installation of the panels.

**METHOD "A"** - One method for checking the roof for squareness is to measure diagonally across one slope of the roof from similar points at the ridge and eave and obtain the same dimension.

**METHOD "B"** - The 3-4-5 triangle system may also be used. To use this system measure a point from the corner along the edge of the roof at a module of three (3). Measure a point from the same corner along another edge at a module of four (4). Then by measuring diagonally between the two points established, the dimension should be exactly a module of five (5) to have a square corner. Multiple uses of this system may be required to determine building squareness. If the endwall cannot be made square, the roof system cannot be installed as shown in these instructions.

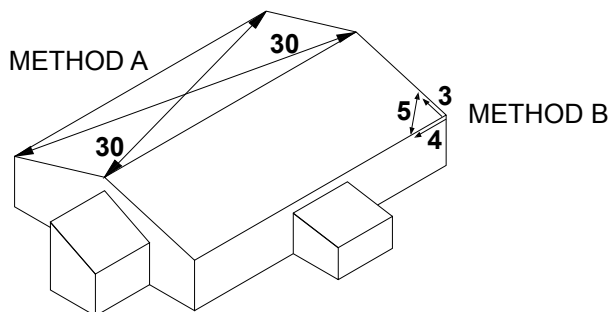

**VENTILATION**

Proper design and installation of vapor barriers and ventilation systems are important to prevent condensation and the resulting problems of moisture damage and loss of insulation efficiency.

Condensation occurs when moisture laden air comes in contact with a surface temperature equal to or below the dew point of the air. This phenomenon creates problems that are not unique with metal roofing; these problems are common to all types of construction.

The underside of the metal roof on a typical Architectural building should be protected from condensation by installing panels directly over a minimum 30 lb moisture barrier and uniform solid substrate. This reduces airspace and the potential of condensation forming on the underside of the panels.

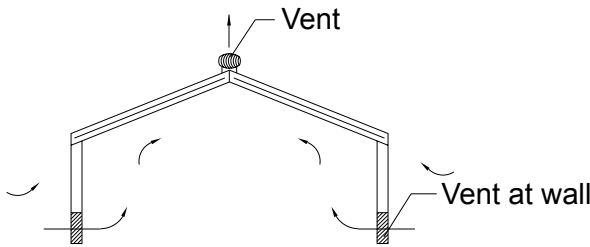

**Typical metal building (no attic)**

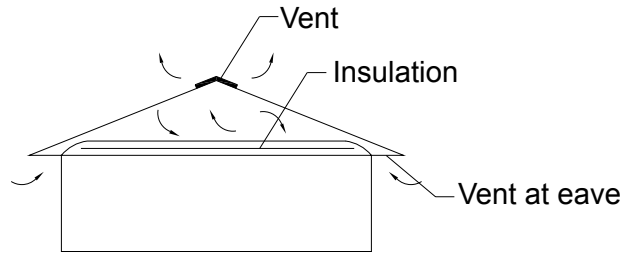

**Building with attic or retrofitted**

**PANEL APPLICATIONS**

The following chart highlights UL 580 #435 for fastener spacing on the selected applications (see Fastener Selection Guide pages PGI-12-14 for other fasteners available). For more information on UL Construction numbers, refer to UL Roofing Materials and System Directories.

PANEL TYPE	APPLICATION	INSTALLATION REQUIREMENTS		FASTENER SPACING	TYPE OF FASTENER	NUMBER REQUIRED
		UL-90	26 GAUGE			
<b>5V-Crimp</b>	FASTENERS OVER 5/8" PLYWOOD DECK CONST. #435	UL-90	26 GAUGE	3'-0" O.C.**	9-15 x 1" ABMP XL - PAINTED	4 FASTENERS*

\* ABMP XL Fastener also available in 1/4"-14 x 1" - Painted.

\*\* Based on UL-580, subject to project loading, closer fastener spacing may be required. Contact your local Metal Sales branch representative for more information (see pages PGI2 - PGI3).



# 5V-CRIMP

## EAVE DETAIL

3:12 Slope  
Minimum

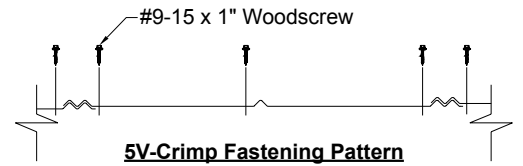
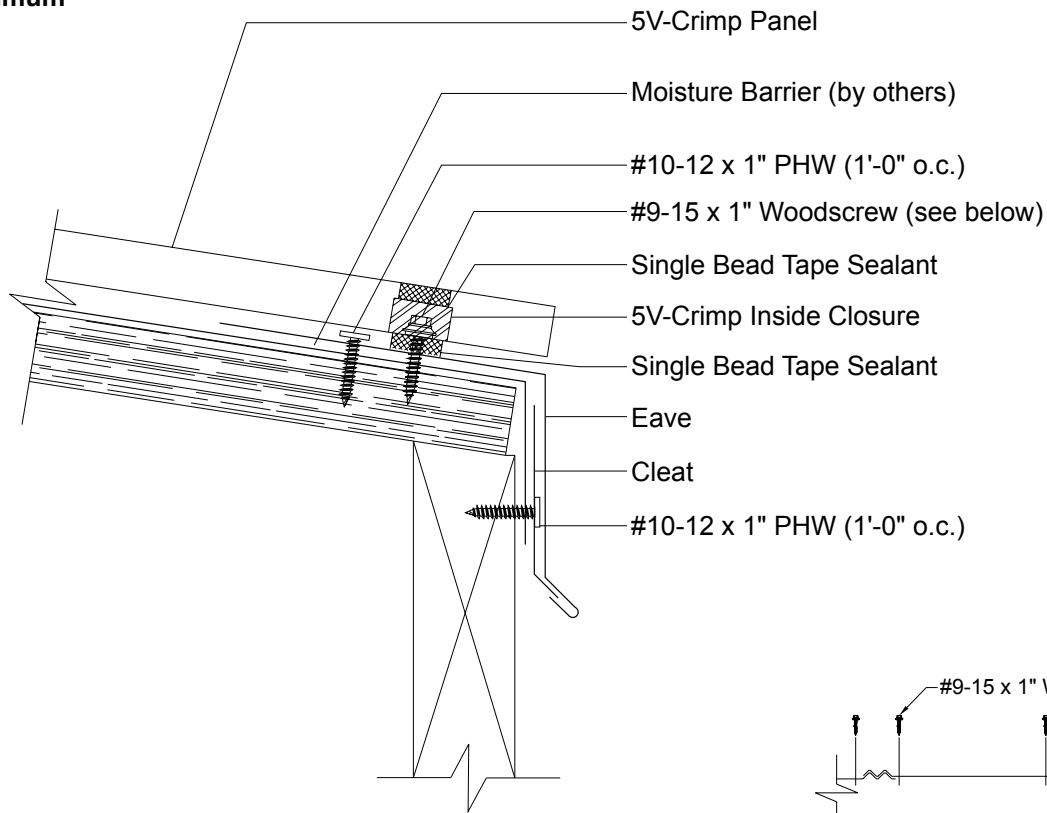

# 5V-CRIMP

## BOX GUTTER DETAIL

3:12 Slope  
Minimum

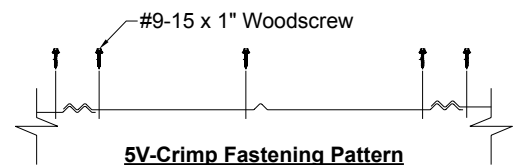
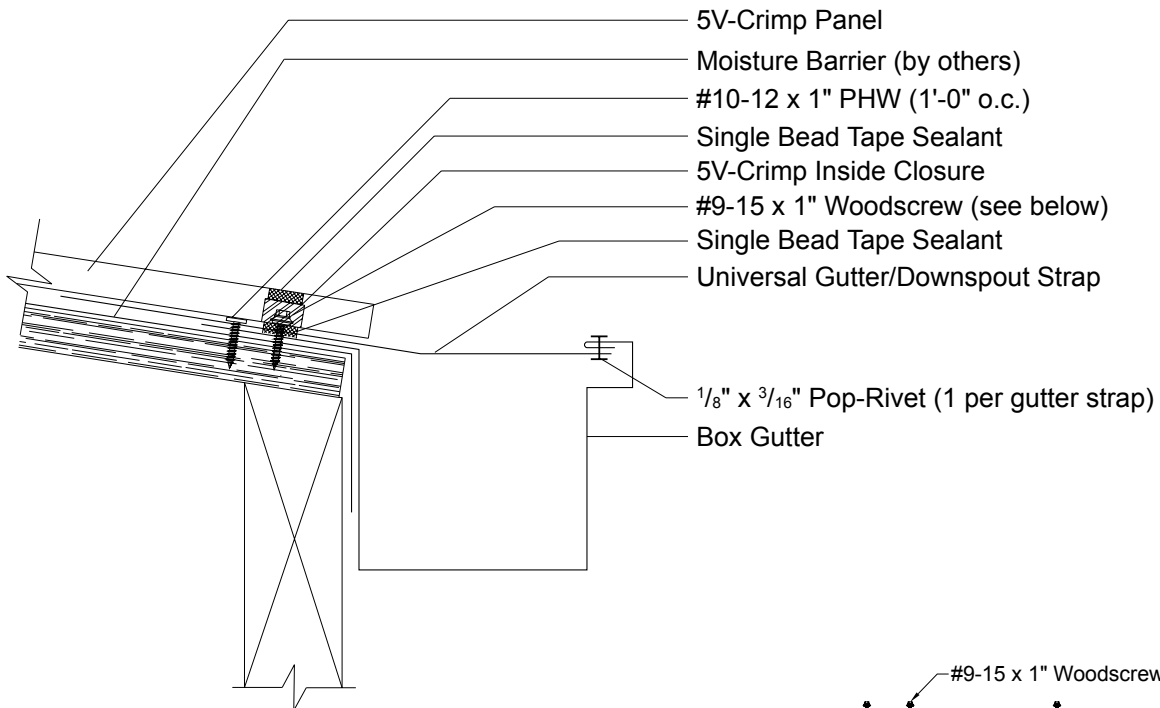

# 5V-CRIMP

## VALLEY DETAIL

3:12 Slope  
Minimum

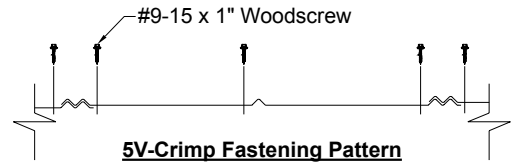
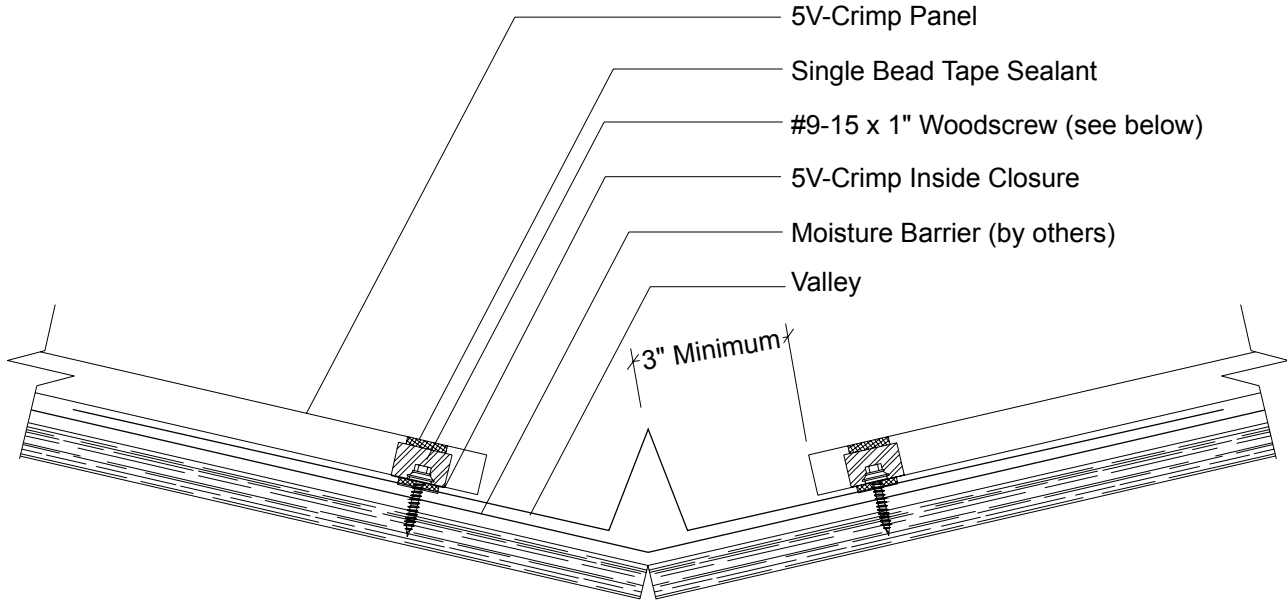

# 5V-CRIMP

## ENDLAP DETAIL

3:12 Slope  
Minimum

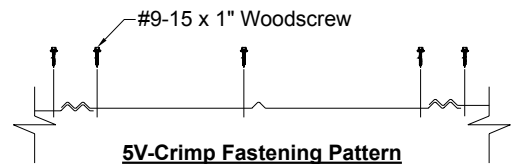
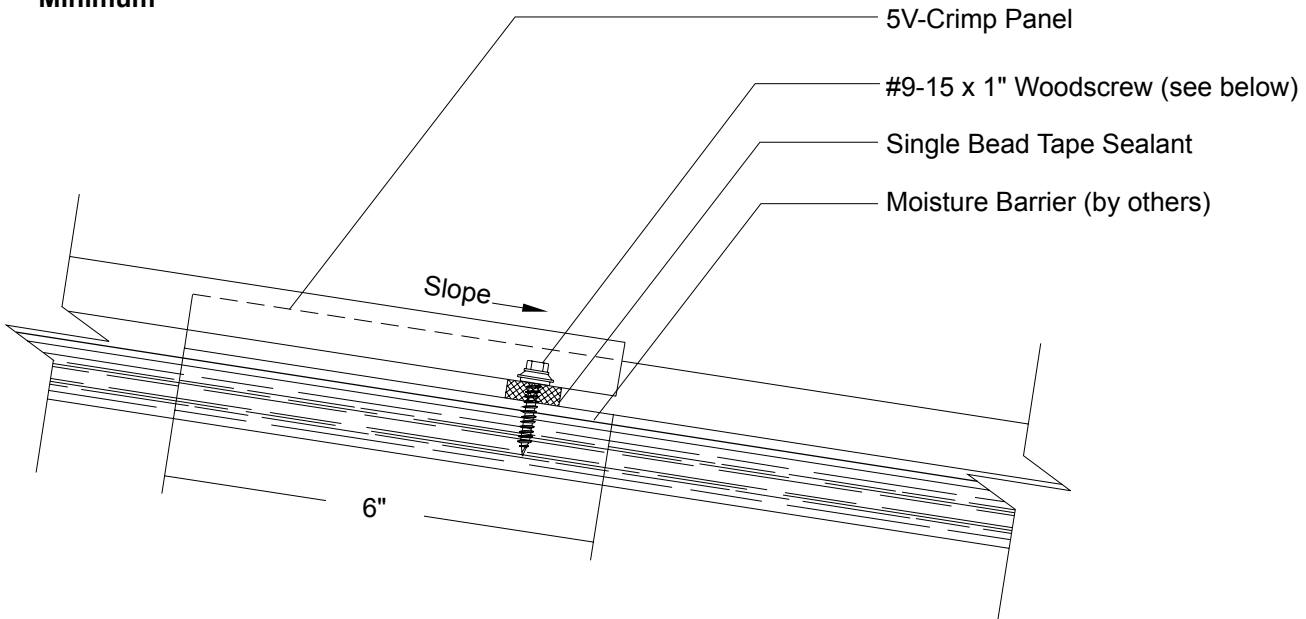

# 5V-CRIMP RAKE DETAIL

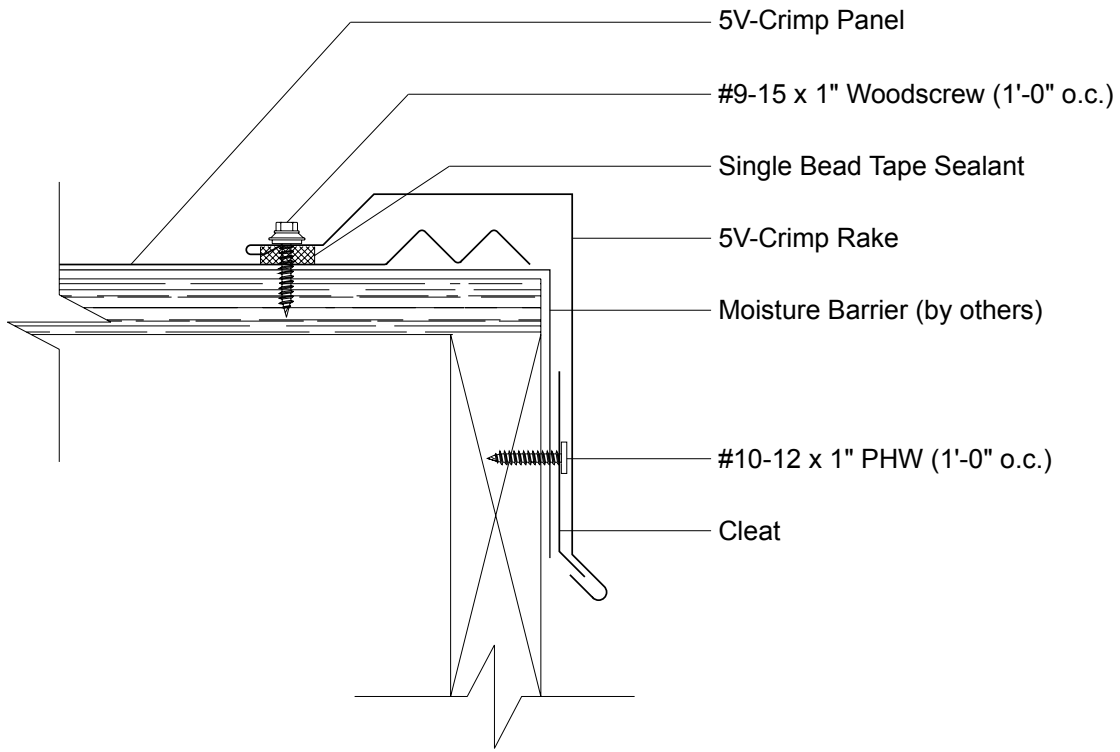

# 5V-CRIMP RAKEWALL DETAIL

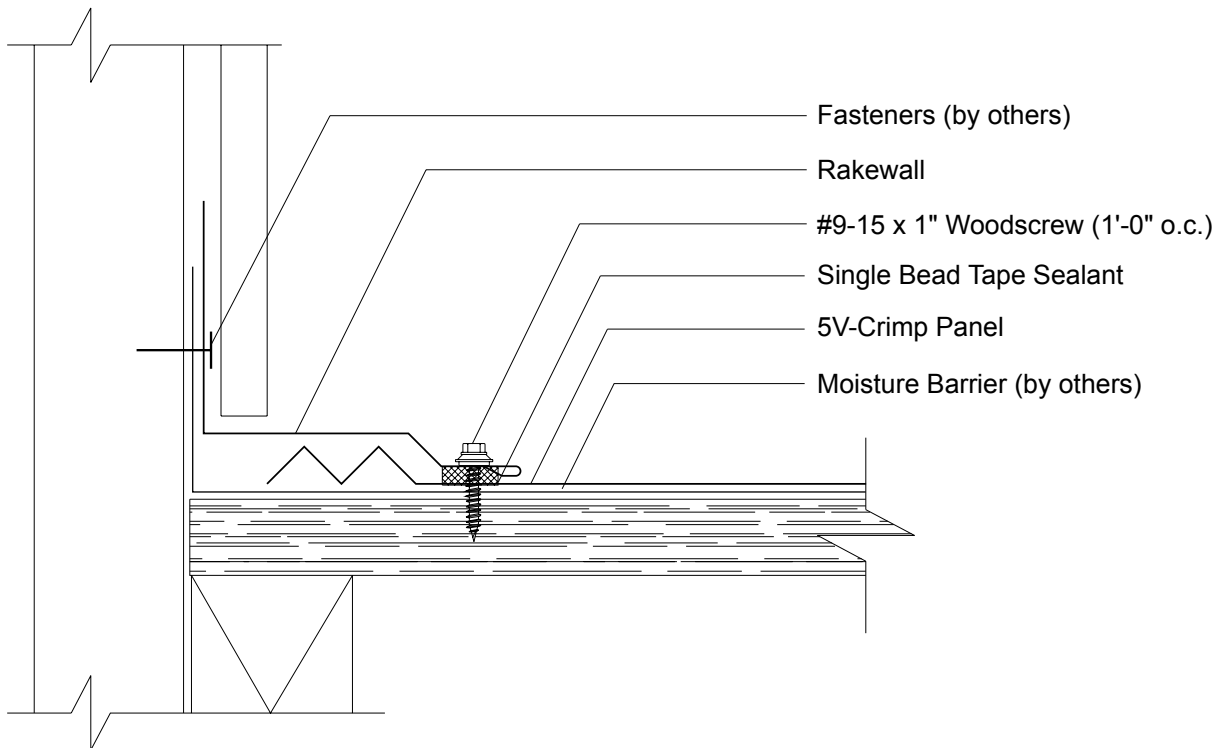

# 5V-CRIMP

## ENDWALL DETAIL

3:12 Slope  
Minimum

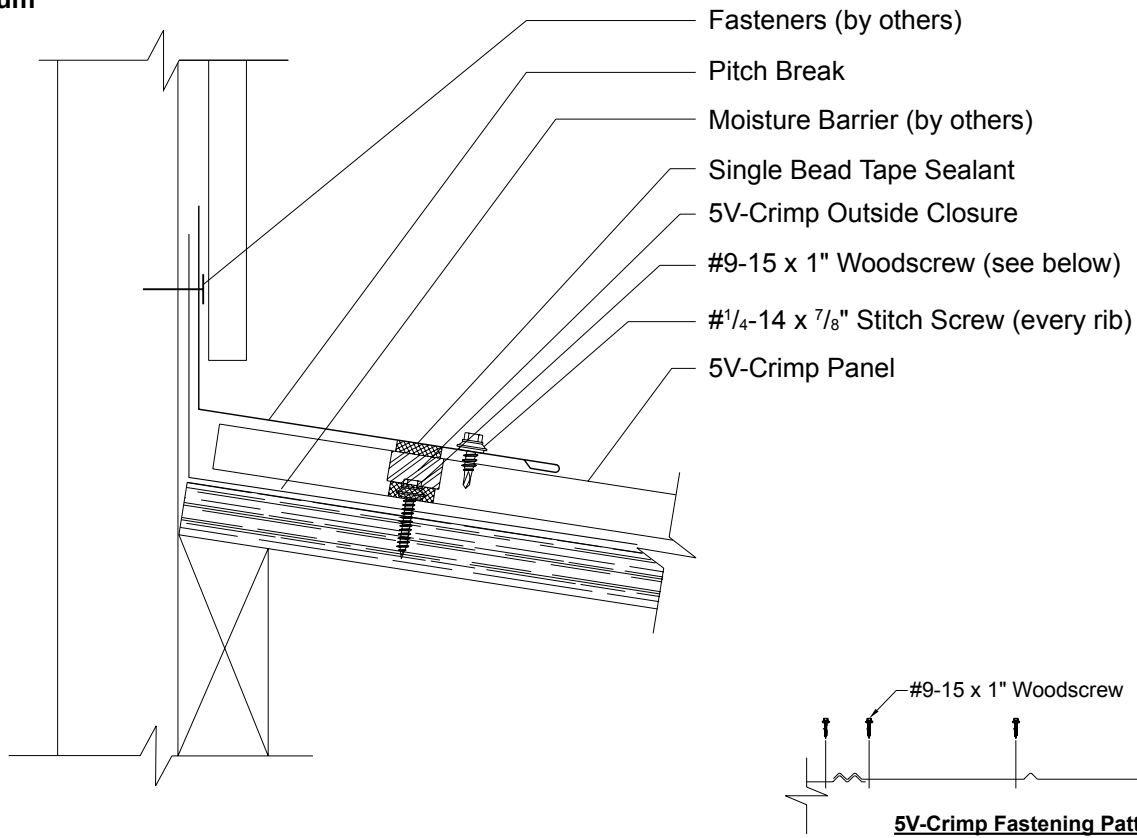

# 5V-CRIMP

## PEAK DETAIL

3:12 Slope  
Minimum

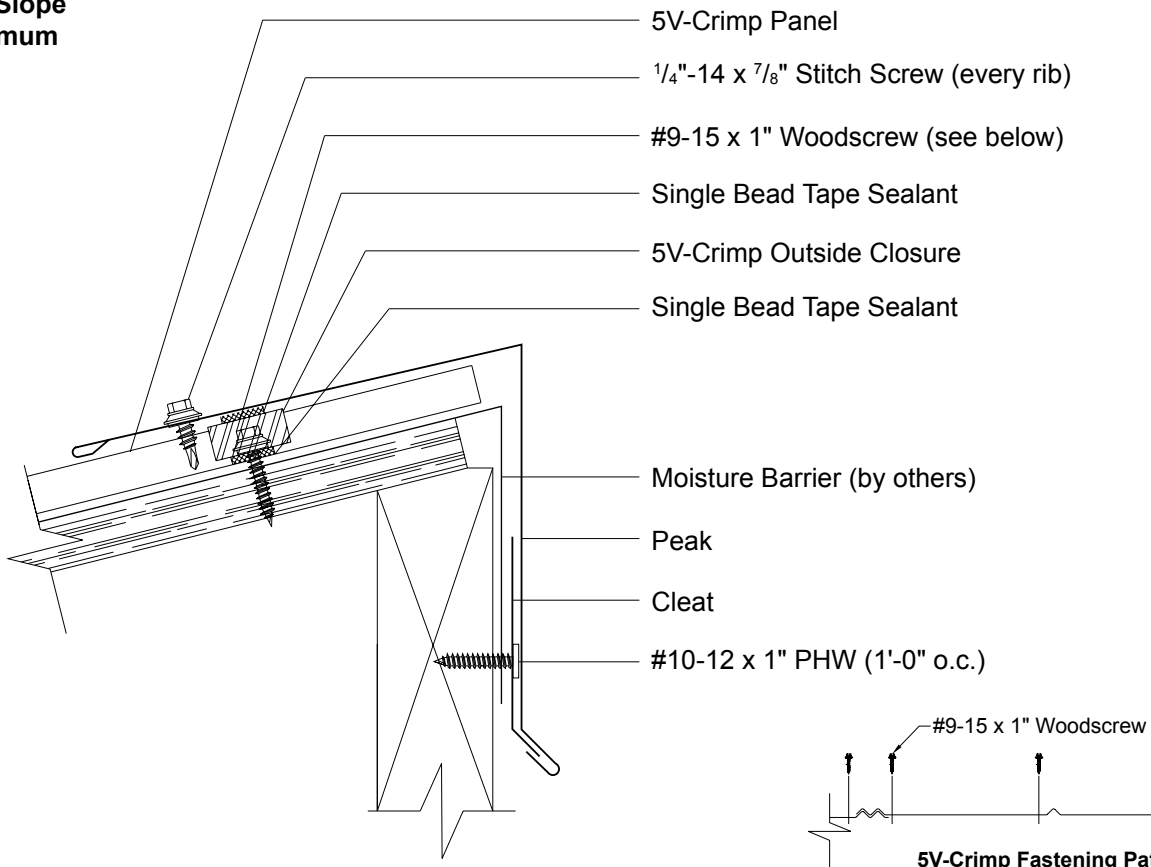

# 5V-CRIMP

## HIP DETAIL

3:12 Slope  
Minimum

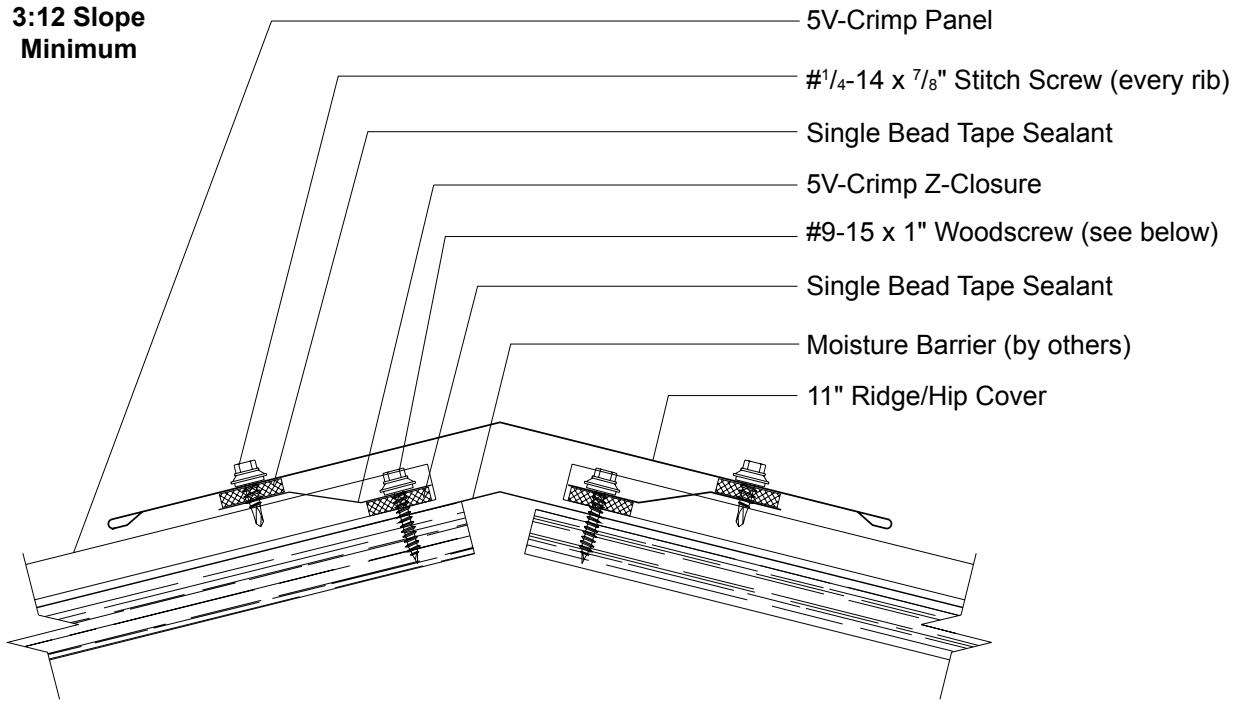

- 5V-Crimp Panel
- #1/4-14 x 7/8" Stitch Screw (every rib)
- Single Bead Tape Sealant
- 5V-Crimp Z-Closure
- #9-15 x 1" Woodscrew (see below)
- Single Bead Tape Sealant
- Moisture Barrier (by others)
- 11" Ridge/Hip Cover

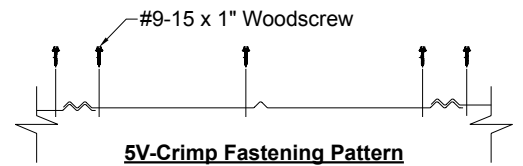

# 5V-CRIMP

## RIDGE DETAIL

3:12 Slope  
Minimum

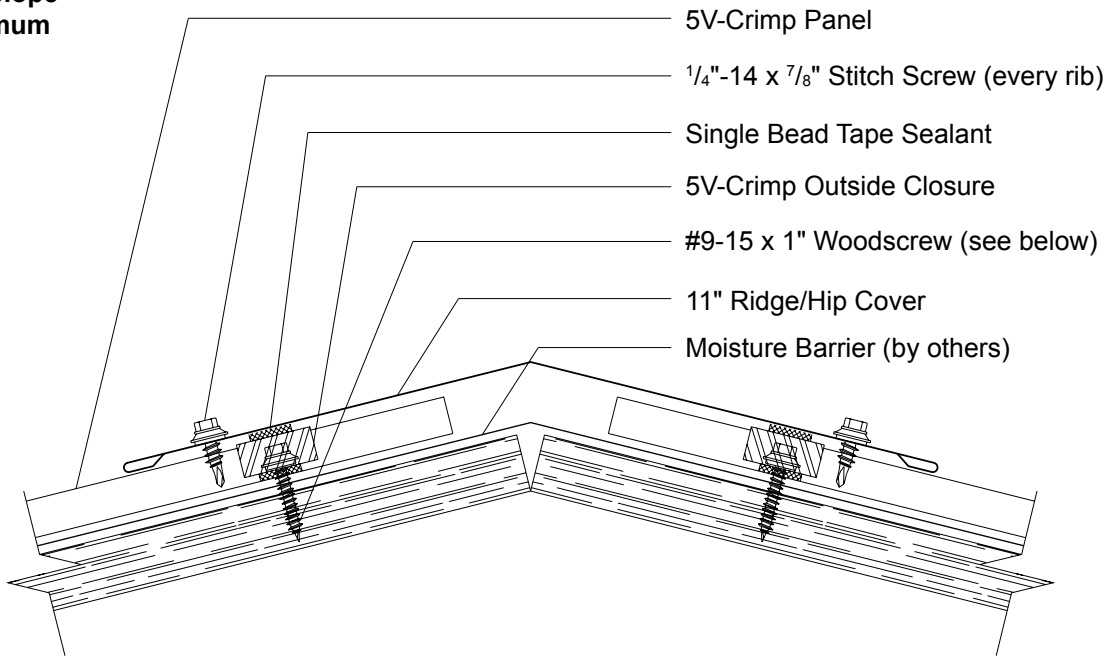

- 5V-Crimp Panel
- 1/4"-14 x 7/8" Stitch Screw (every rib)
- Single Bead Tape Sealant
- 5V-Crimp Outside Closure
- #9-15 x 1" Woodscrew (see below)
- 11" Ridge/Hip Cover
- Moisture Barrier (by others)

