

MINI-BATTEN

1" MINI-BATTEN

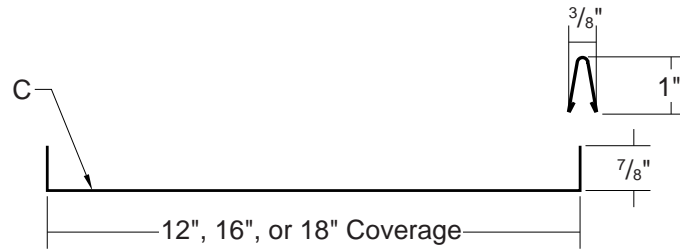

1 1/2" MINI-BATTEN

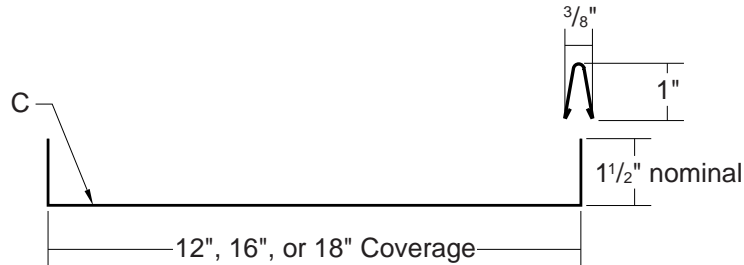

ARCHITECTURAL
PANEL

CONCEALED
FASTENERS

12", 16", OR 18"
COVERAGE

MINIMUM
3:12 SLOPE

SOLID WOOD
SUBSTRATE

PANEL OVERVIEW

- ▶ Finishes: Kynar 500 (PVDF), MS Colorfast45[®], and Acrylic Coated Galvalume[®]
- ▶ Gauges: 26ga and 24ga standard, 22ga optional
- ▶ 12", 16", or 18" panel coverage, 1" or 1 1/2" high rib utilizing a narrow batten cap
- ▶ Concealed clip designed to accommodate thermal movement
- ▶ Applies over plywood substrate with 30 pound felt underlayment
- ▶ Available for curved applications (see back for curving specifications)
- ▶ Architectural standing seam panel
- ▶ Minimum roof slope: 3:12
- ▶ Water shedding panel

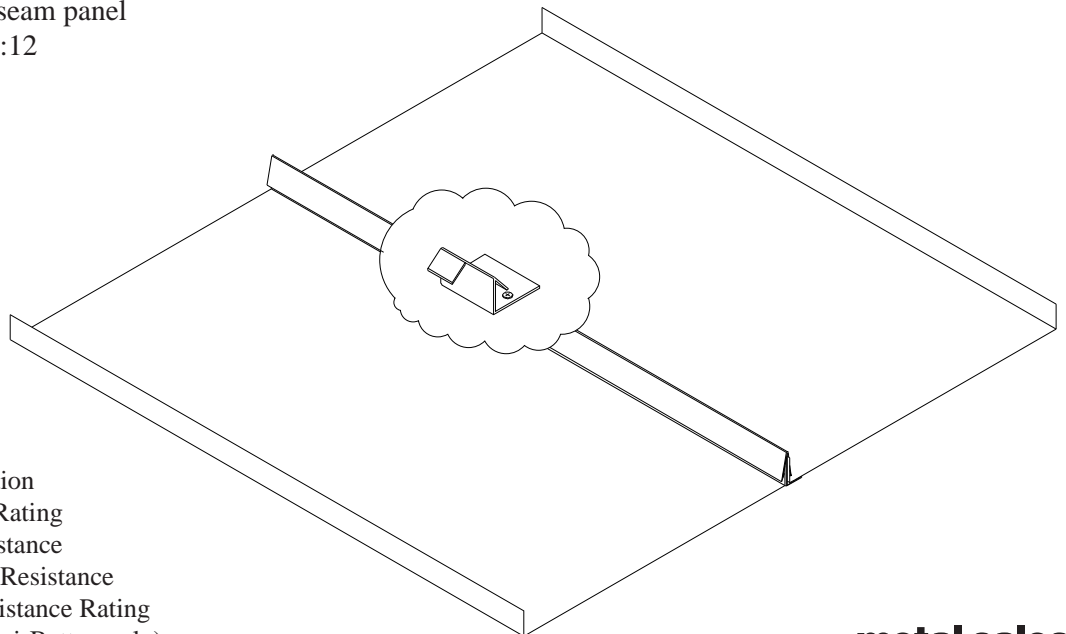

TESTING

- ▶ ASTM E-283 Air Infiltration
- ▶ UL 263, Fire Resistance Rating
- ▶ ASTM E-331 Water Resistance
- ▶ UL 2218, Class 4 Impact Resistance
- ▶ UL 790, Class A Fire Resistance Rating
- ▶ Rated ASTM E-1592 (Mini-Batten only)
- ▶ UL 580, Class 90 Wind Uplift, Construction Number 430 over 5/8" plywood deck (applies to 1" Mini-Batten only)

metal sales
manufacturing corporation

ms

MINI-BATTEN

ATTACHMENT DETAILS

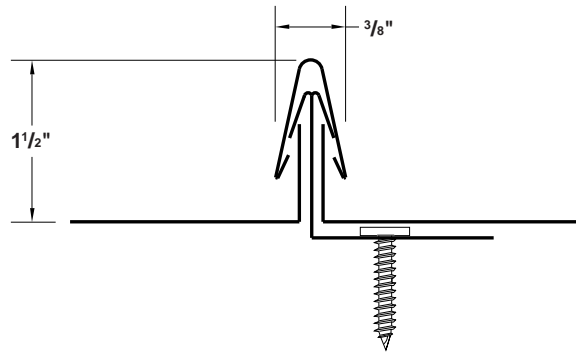
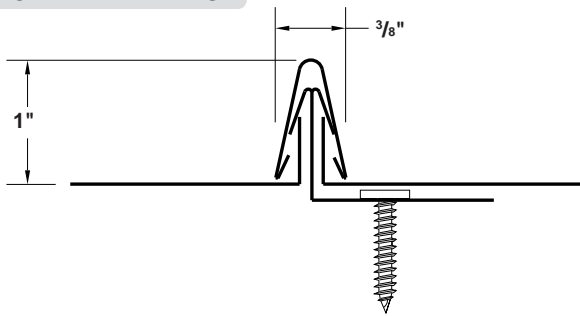

PANEL CLIPS

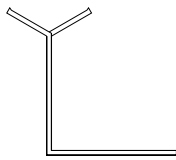
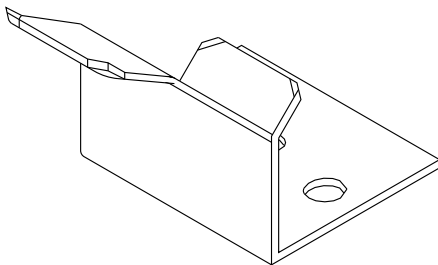

MINI-BATTEN
(1 1/2" standing seam height)

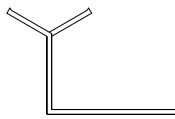

MINI-BATTEN
(1" standing seam height)

CURVING SPECIFICATIONS

1" Mini-Batten: 12", 16", 18"

Minimum Radius : 4'-0" Pan & Batten

For panel lengths over 25'-0", please inquire

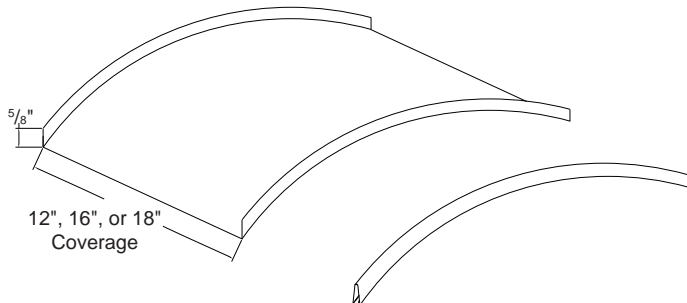

GENERAL INFORMATION

► Slope

The minimum recommended slope for Mini-Batten roof panel is 3:12.

► Substructure

The recommended substrate is 5/8" plywood with a 30 pound felt moisture barrier. To avoid panel distortion, use a properly aligned and uniform substructure.

NOTE: Mini-Batten roof panels are not recommended for use over open structural framing.

► Coverage

Mini-Batten panels are available in 12", 16", or 18" widths in either 1" or 1 1/2" rib heights.

► Length

Minimum factory cut length is 5'-0". Maximum recommended panel length is 45'-0". Longer panels require additional consideration in packaging, shipping, and erection. Please consult Metal Sales for recommendations.

► Fasteners

The fastener selection guide should be consulted for choosing the proper fastener for specific applications. Quantity and type of fastener must meet necessary loading and code requirements.

NOTE: All panels are subject to surface distortion due to improperly applied fasteners. Overdriven fasteners will cause stress and induce oil canning across the face of the panel at or near the point of attachment.

► Availability

Finishes: Acrylic Coated Galvalume®, MS Colorfast45®, or various Kynar 500 (PVDF) colors.

Gauges: 26ga and 24ga standard, 22ga optional

► Oil Canning

Oil canning is not a cause for rejection. Heavier gauges and narrower widths minimize oil canning.

► Loading Information

Mini-Batten 1" must be installed over solid substrate. Panel attachment to substrate at fixed locations must be checked for drag loads. Please contact Metal Sales Technical Services for the latest ASTM E-1592 uplift design loads (available on Mini-Batten 1" high, 12" and 16" wide 24 Gauge). Mini-Batten 1.5" must be installed over solid substrate. Panel fixity must be checked for drag loads.

metal sales
manufacturing corporation



Kent, WA (800) 431-3470
Temple, TX (800) 543-4415
Longmont, CO (800) 289-7663
Antioch, TN (800) 251-8508
Woodland, CA (800) 759-6019
Rogers, MN (800) 328-9316
Spokane, WA (800) 572-6565

Jefferson, OH (800) 321-5833
Rock Island, IL (800) 747-1206
Sellersburg, IN (800) 999-7777
Jacksonville, FL (800) 394-4419
Orwigsburg, PA (800) 544-2577
Independence, MO (800) 747-0012
Fontana, CA (800) 782-7953

Anchorage, AK (866) 640-7663
Bay City, MI (888) 777-7640
Detroit Lakes, MN (888) 594-1394
Mocksville, NC (800) 228-6119

©MS1280MNB/11-2006