

fischer Zykon-Panel Anchor FZP-II-T

Product description

Undercut anchor for thin panel materials e. g. ceramic and fine stoneware, HPL, fibre cement and solid surface materials. Application with bracket systems or other attachment parts.

Advantages / benefits

- Anchoring not visible from front of facade
- Stress-free fixing
- Static optimised position of anchor
- Large panel sizes possible
- High load capability
- Optimised for long-life

Installation

Special drilling machines from fischer, are necessary for the drilling of the undercut hole. The anchor will be installed by a special fischer setting tool.

Approval



soon available

Drilling / anchor setting

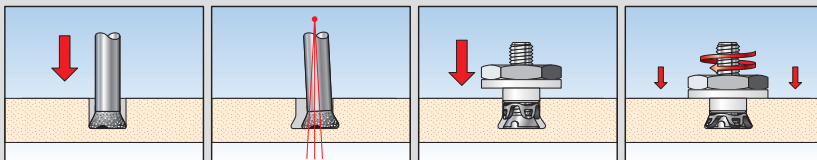

Technical data

Type	Item	Installed anchor length mm a	Drill hole Ø mm	Colour code of shim washer	Anchorage depth mm	Thread diameter	Bolt projection length mm b	Box quantity pieces
FZP-II 11x 6 M6/T/10 Al	512 959	12,5	11	red	6	M6	10,0	250
FZP-II 11x 7 M6/T/9 Al	512 960	13,5	11	grey	7	M6	9,0	250
FZP-II 11x 8 M6/T/10 Al	513 633	14,5	11	yellow	8	M6	10,0	250
FZP-II 11x 9 M6/T/9 Al	513 634	15,5	11	blue	9	M6	9,0	250
FZP-II 11x 10 M6/T/13 Al	512 961	16,5	11	green	10	M6	13,5	250

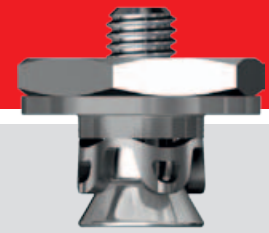

Application example

- **Anchor in panel**
FZP-II-T, ceramic



- **Framework**

Facade panel with FZP-II-T suspended on SystemOne light framework

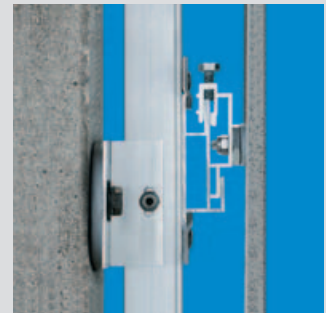

- **Ceramic facade**

installed with FZP-II-T anchor for thin panel materials

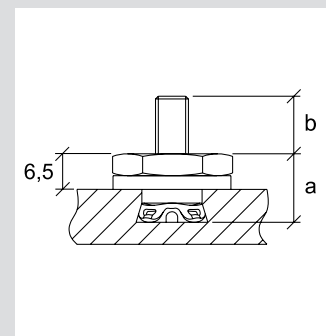

ACT Service

fischerwerke GmbH & Co. KG

Werk Altheim · Hindenburgstr. 81 · D-72160 Horb

Phone +49 (0)74 43 12-45 53 · Fax +49 (0)74 43 12-49 07

act@fischer.de · www.fischer.de