

fischer Zykon-Panel Anchor FZP-II-SO

Product description

Undercut anchor for natural stone from 2 cm panel thickness. Application with bracket systems or other attachment parts.

Advantages / benefits

- Stress-free fixing in natural stone
- Anchoring not visible from front of facade
- Static optimised position of anchor
- Higher collapse loads than traditional systems
- Compensating panel thickness tolerances by constant remaining wall thickness



Installation

Special drilling machines from fischer, are necessary for the drilling of the undercut hole. The anchor will be installed by a special fischer setting tool.

Drilling / anchor setting

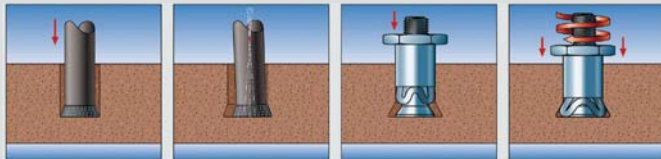

Approval



Technical data

Type	Item	Installed anchor length mm a	Drill hole-Ø mm	Anchorage depth mm	Thread diameter	Bolt projection length mm b	Box quantity pieces
FZP-II 11x21 M6/SO/9 AL *	512 144	21	11	12-16	M6	9	250
FZP-II 11x21 M6/SO/12 AL *	512 145	21	11	12-16	M6	12	250
FZP-II 13x26 M8/SO/17 AL *	512 146	26	13	15-21	M8	17	250
FZP-II 13x30 M8/SO/13 AL *	513 226	30	13	15-25	M8	13	250

* European Technical Approval ETA-11/0145

Application example

■ **Anchor in panel**
FZP-II-SO, granite



■ Framework

Facade panel with FZP-II-SO suspended on SystemOne framework



■ Natural stone facade

Administration building NCC, Copenhagen, Otta-slate SystemOne light on steel skeletonframe structure

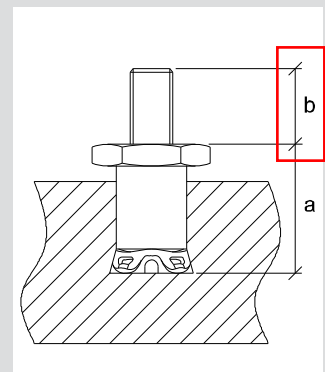

ACT Service

fischerwerke GmbH & Co. KG

Werk Altheim · Hindenburgstr. 81 · D-72160 Horb

Phone +49 (0)74 43 12-45 53 · Fax +49 (0)74 43 12-49 07

act@fischer.de · www.fischer.de