

# Luxury Lift 950 - Hydraulic Home Elevator

**QUALITY • SAFETY • DEPENDABILITY • BEAUTY • ENGINEERING EXCELLENCE**



Residential Elevators, Inc. (REI) is pleased to offer our **Luxury Lift** hydraulic elevator line with our largest size and payload ever. The **Luxury Lift 950** hydraulic elevator has an industry leading 950lb capacity - ***STANDARD!***

**Benefits:** The **Luxury Lift 950** residential elevators are built using the same design criteria developed over decades and used in the commercial and industrial elevator market. REI's **Luxury Lift 950** gives the lifting capacity normally available only with commercial elevators. Complement the **Luxury Lift 950** with your personal choice cab appointments and enjoy commercial elevator features at residential elevator prices.

Low maintenance consistent with REI's reputation and demonstrated track record for effective and highly engineered hydraulic elevators with affordable cost and beautiful finish.

- ***Factory Direct Savings!***
- Only 96" of clear overhead needed and an 8" recessed pit
- Can accommodate hoistway up to 55-1/2" x 63-1/2"
- Platform size up to 42" x 58-1/2"

#### **Custom Features To Your Order:**

REI will custom build many upgrades to your exact specifications including: extra gates, change of cab height, observation glass panels, frame and panel, recessed phone box, keyed hall station, custom interior, custom fixtures, power gates, and much more.

#### **STANDARD FEATURES:**

- Free job site survey by one of our trained representatives
- One (1) year warranty
- Standard car capacity 950 lb.
- Provides for up to 50 ft. of travel standard
- Travel speed of 40 ft. per minute
- Two speed leveling valve
- 3/4" sturdy cab walls (7ply custom cabinet grade material)
- Custom made cab and interior to your specifications
- Automatic emergency-lowering feature
- Aluminum anodized scissor gate or accordion style solid gate
- Standard interior cab color choices:  
(Pre-finished Birch or Oak and Classic White)
- Solid matching hardwood handrail
- Recessed lighting
- Interior cab emergency light
- Single integrated car operating panel with built in phone and emergency light
- Meets or exceeds all ANSI A17.1 National Safety Codes for elevator safety.

#### **OPTIONAL SELECTIONS:**

- Woods other than standard
- Additional gates
- Custom gate
- Oversize cab
- Over height cab up to 8'-0"
- Variety of custom cabs
- Observation glass panel inserts
- 750 lb. capacity (50' - 0" max.)
- Mirror w/hardwood trim
- Halogen downlights
- Keyed hall station
- Remote diagnostics and monitoring
- "Car Here" and "In Use" indicators
- Auto homing / auto light timer
- And much more - Contact your local REI representative for all the details and options



#### **RESIDENTIAL ELEVATORS, INC. Tallahassee, FL**

20 Residential Drive, Crawfordville, FL 32327  
Ph (850) 926-6022 • Toll Free (800) 832-2004 • Fax (850) 926-5319  
www.ResidentialElevators.com  
e-mail: sales@ResidentialElevators.com

# Luxury Lift 950 - Hydraulic Home Elevator

## Standard Hoistway Plans

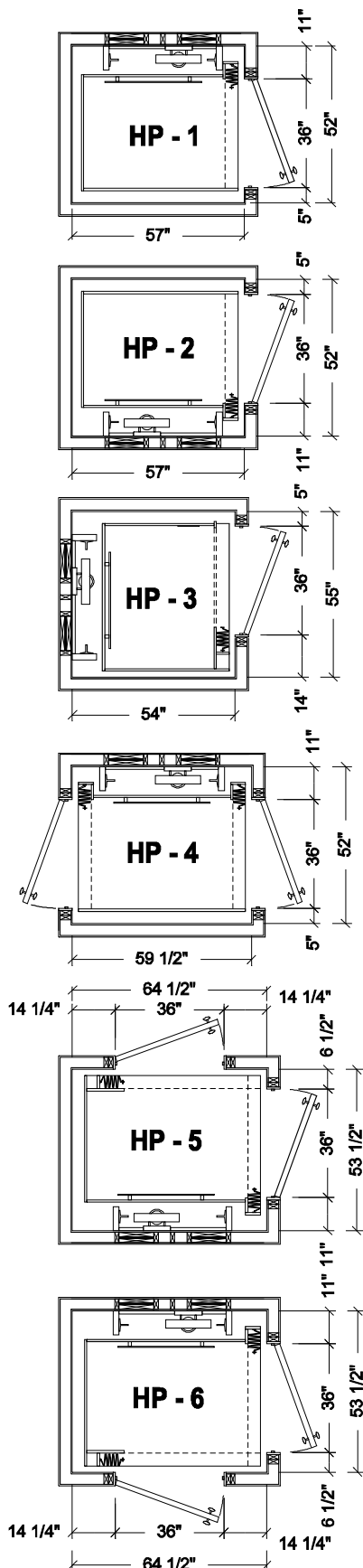

## Hydraulic Residential Elevator Contract Specifications

**To Specify:** The manufacturer shall furnish \_\_\_\_\_ hydraulic residential elevator(s) (LL-952, LL953, LL954, LL-955) as manufactured by Residential Elevators, Inc. for hoistway plan \_\_\_\_\_

**Design Characteristics:** Hydraulic elevator(s) shall have:

**Capacity:** 950 lb.

**Speed:** 40 fpm

**Ratio:** 1:2 Roped Holeless

**Travel:** \_\_\_\_\_ ft. \_\_\_\_\_ in. (50' - 0" max.) Approx.

**Landing Served:** \_\_\_\_\_: with openings at \_\_\_\_\_ front, \_\_\_\_\_ rear, \_\_\_\_\_ right, \_\_\_\_\_ left

**Door Size:** (\_\_\_\_\_ w x \_\_\_\_\_ h) **Door Swing:** Right: \_\_\_\_\_ Left: \_\_\_\_\_

**Hoistway:** (Size \_\_\_\_\_ x \_\_\_\_\_) **Cab:** (Size: \_\_\_\_\_" w x \_\_\_\_\_" d x \_\_\_\_\_" h)

**Hoistway Pit:** 8" Minimum

**Cab Interior Finish:** Unfinished Birch: \_\_\_\_\_ Unfinished Oak: \_\_\_\_\_ Classic White: \_\_\_\_\_

Natural Oak: \_\_\_\_\_ Natural Birch: \_\_\_\_\_ Pickled Birch: \_\_\_\_\_ Pickled Oak: \_\_\_\_\_ Other: \_\_\_\_\_

**Cab & Hall Stations:** Stainless Steel (#4 or #8): \_\_\_\_\_ Bronze (brushed or antique): \_\_\_\_\_

**Hydraulic Power Unit:** A power unit especially designed and manufactured for this service shall be furnished. It shall include a constant displacement rotary screw type pump, submersible pump motor, oil reservoir, hydraulic control unit and oil level gauge. The hydraulic control unit shall include a safety check valve, an UP direction valve with high pressure relief including UP leveling and soft stop features, a lowering valve including DOWN leveling and a manual lowering feature (Two-Speed Valve); all encased in a compact unit assembly. The control valves shall be solenoid operated and designed to open and close gradually to give smooth starts and stops. All valves shall be readily accessible for adjustments. The power unit shall be located near the hoistway at the lowest landing, and shall be contained in a metal cabinet with a lock-able lid.

**Controller:** The controller components shall be enclosed in a metal cabinet with a hinged door. It shall contain the following components: Power relays and overload device suitable for the size motor and power supply. A microprocessor unit for all logical control and safety circuits. All components to be protected by fused circuits. An emergency, battery operated circuit, shall be incorporated in the control logic to automatically provide emergency lighting and lower the lift in the event of an electric power failure. Batteries to be maintained at full charge by a trickle charge circuit during normal operation.

**Guide Rails:** Shall be two (2) 8 lb. planed T section with smooth splices, located on one load bearing hoistway wall to accurately guide the cab and piston and shall be secured to that wall by suitable steel brackets and hardware.

**Suspension:** The steel car frame shall be attached to and suspended by two (2) 3/8" heavy duty aircraft cables. The cables shall be fastened to the pit structure on one end and pass over the U groove sheave to shackles attached to the car frame and safety device. Should one or more cables break or slacken, a broken rope safety mechanism shall apply two cams to wedge against the elevator guide rails and bring the car to a complete stop.

**Plunger:** The plunger shall be manufactured from accurately ground and polished seamless steel tubing. The bottom of the plunger shall be fitted with a heavy steel disc Stop Ring welded in place and provided with a suitable extended edge to provide a positive stop designed to prevent the plunger from leaving the cylinder in the up direction. The top of the plunger shall be provided with an internally welded steel disc drilled and tapped for fastening a U-groove sheave for 1:2 roping application.

**Cylinder:** The cylinder shall be machined from steel pipe with a steel flange at the upper end and a heavy steel bulkhead welded in the lower end. The cylinder shall be provided with a suitable steel fitting for connecting the oil line and shall be provided with an air bleeder.

**Pipe Rupture Valve:** An automatic shut-off valve in the oil supply line at the cylinder inlet will be provided. When there is a drop in no-load operating pressure, or an overspeed in the down direction, the automatic shut-off valve shall be actuated and immediately stop the elevator.

**Note to Installers:** Because this cab is assembled with a unique hardware system, the complete elevator can be installed within hoistway at its final stage of completion.

### Work By Others:

1. Construction of a suitable, clean, clear, square, plumb (including pit) and legal elevator hoistway consistent with State and Local building codes. (Refer to manufacturer's hoistway plans.)
2. Electrician shall furnish 230V, 30AMP circuit with 10/3 wire with ground to be located in machine area with Fused Disconnects.
3. Electrician shall furnish a 115V, 15 AMP circuit to machine area for the car lighting system with Fused Disconnects.
4. Suitable, hinged, solid core hall doors. Door openings are 3'-0" standard unless otherwise specified.
5. 8" deep recessed pit area.
6. Connection of telephone traveling cable to outside central exchange as required by ANSI 17.1 code.
7. Special engineered Drawings or plans and any State, County or Local Permits.
8. Proper rail blocking support per "REI" specifications.

**Standard Hoistway Plans, as drawn,  
are recommended size requirements only.  
Contact REI for layout assistance if your needs are different.**

**RESIDENTIAL ELEVATORS, INC.**  
www.ResidentialElevators.com - Toll Free (800) 832 - 2004