

## Product Cut Sheet: 1 1/2" x 1" Elite Contoured Aluminum Mini-Blind System

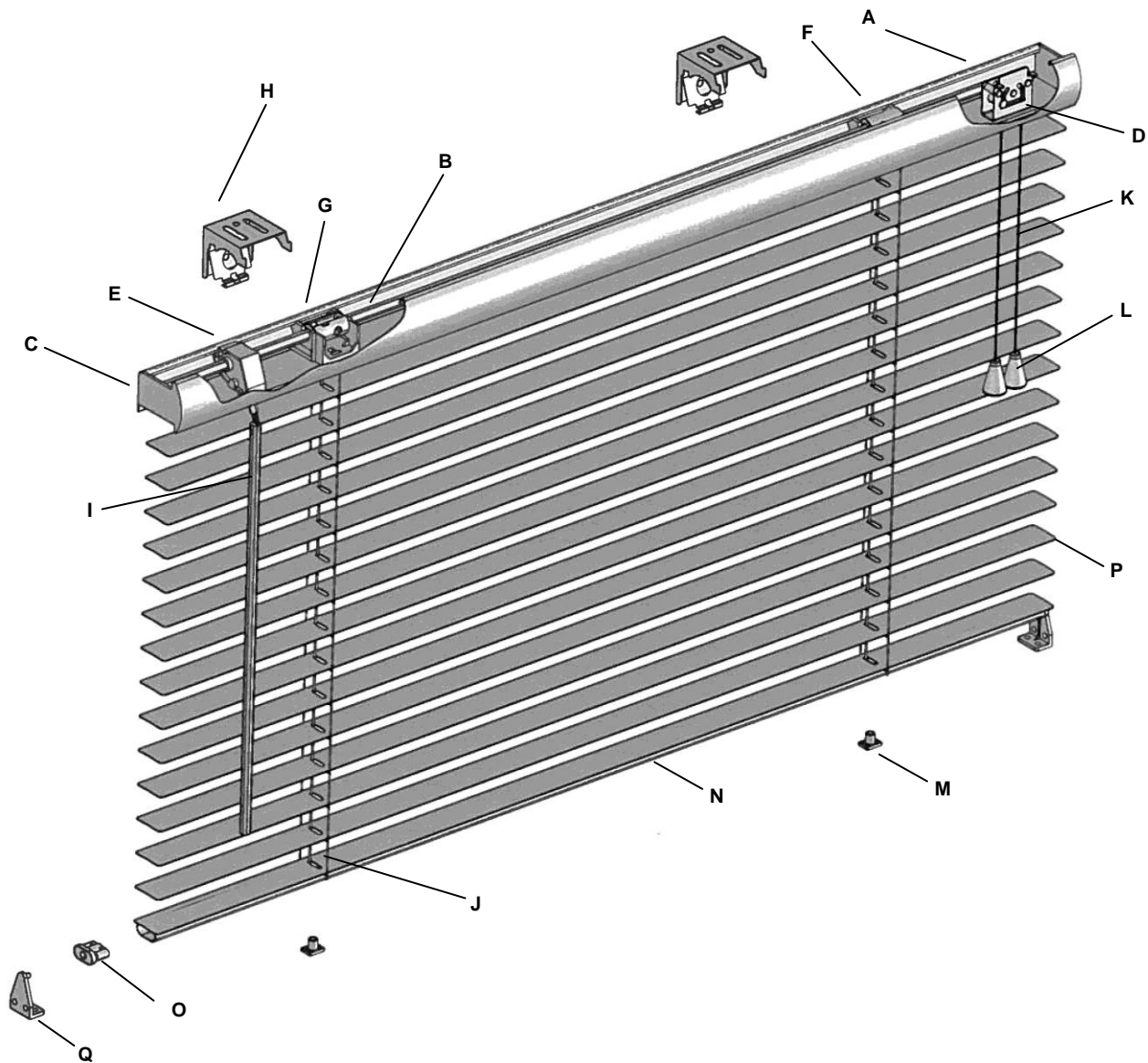

### Parts:

- |                                      |                                  |
|--------------------------------------|----------------------------------|
| A) Headrail – Steel                  | J) Cord Ladder                   |
| B) Pinion Rod (Tilt Rod) – Hexagonal | K) Lift Cord 1.4mm               |
| C) Headrail End Caps (Clear)         | L) Cord Tassels                  |
| D) Cord Lock                         | M) Bottomrail Plugs              |
| E) Wand Tilter                       | N) Bottomrail – C Shape          |
| F) Tape Drum (Ladder Drum)           | O) Bottomrail End Caps           |
| G) Tape Drum Support (Cradle)        | P) Slats                         |
| H) Hidden Installation Bracket       | Q) Hold Down Brackets - Optional |
| I) Wand – Clear Hexagonal            |                                  |

### System Features:

- Integrated Headrail with Light Blocking Lip
- Snap-in Hidden Installation Brackets
- Heavy Duty Metal and Plastic Components
- Wand Tilter has a clutch mechanism preventing over-rotation and repairs

# Product Cut Sheet: 1 1/2" x 1" Elite Contoured Aluminum Mini-Blind System

## Blind Options:

- Elite Mini-Blind – 1 1/2" x 1" Headrail with 6-Gauge Aluminum Slats

### Headrail:

- Polyester baked enamel – color coordinated
- Phosphate treated steel – 1 1/2" x 1" high
- Wall thickness – 0.024" (before paint)



### Lift Cords: *(Color Coordinated)*

- 1.4mm Polyester braided cords designed for lifting and lowering the blind



### Bottomrail: *(Color Coordinated)*

- Steel – C shape
- Phosphate treated steel
- Wall thickness – 0.024" (before paint)
- Clear plastic end caps

### Tilt Controls:

#### **Wand Tilt Option**



- The tilt mechanism features a clutch that prevents over-rotation and repairs
- The worm and gear arrangement is entirely enclosed inside an acetal thermoplastic housing

### Control Locations: *(Restrictions may apply)*

- Standard: Tilter – Left / Lift Cords – Right
- Reverse: Tilter – Right / Lift Cords – Left
- Same Left: Tilter – Left / Lift Cords – Left
- Same Right: Tilter – Right / Lift Cords – Right

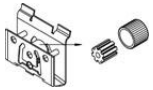

### Lift Control (Cord Lock):

- Snap-in design incorporates a stainless steel wear guard over which cords pass
- Incorporates a "Crash Proof" safety feature that locks the blind automatically upon release of cords

### Other Headrail Channel Hardware:

- Headrail components are made of a combination of metal and low friction acetal thermoplastics
- Snap-in design of components allows for quick and easy repair if necessary



### Cord Ladder: *(Color Coordinated)*

- Polyester braided cord ladders are designed to ensure proper control with adequate overlap of slats when in the closed position

### Cord Ladder Spacing:

- Maximum spacing between rout holes is 20"
- Options:
  - Builder Ladder: 22.5mm (13.5 Slats/Ft.)
  - Contract Ladder: 21.5mm (14.2 Slats/Ft.)
  - Classic Ladder: 19.5mm (15.7 Slats/Ft.)
  - Privacy Ladder: 18.0mm (16.9 Slats/Ft.)

*Privacy ladder features an offset route hole that provides for increased light blocking.*