



Riviera® Contract 1" Blind

Model #RIV1C

Competitively positioned 1" horizontal aluminum window covering for commercial applications.



KEY FEATURES:

- **DustGuard**
- **Headrail: 1" high x 1½" wide**
- **Nominal .006" slat thickness**
- **21.5mm ladder spacing**
- **Guardian Tilter™ disengaging clutch mechanism**
- **Limited lifetime warranty**
- **90% recycled slat material**

PRODUCT OVERVIEW

The Riviera Contract 1" Blind represents Levolor's quality horizontal blind backed by the lifetime warranty. Committed to both durability and aesthetics, the Riviera Contract 1" blind combines the highest quality components with visibly attractive features to provide an overall superior product.

The durable and sleek headrail is made of roll-formed corrosion-resistant Tomized® steel. The strength of the overall headrail profile provides smooth operation, even under heavy loads associated with large window applications. The steel hardware is machine-clinched, ensuring accurate alignment of moving parts and long, maintenance-free operation.

The nominal .006" thick slats are made of 5000 series magnesium aluminum alloy which includes 90% or higher recycled aluminum materials and provides overall strength and resiliency, guaranteeing a quality look for the life of the blind. The Riviera Contract 1" Blind's 21.5mm ladder spacing ensures tight closure and optimum light control. The exclusive Guardian Tilter™ disengaging clutch mechanism eliminates over rotation of the tilt wand and protects the tilt mechanism against breakage.

The Riviera Contract 1" Blind is offered in a large selection of popular colors. Options include the Top-Lok Cord Lock, which holds the blind completely up or down for a consistent look across all windows.

Riviera® Contract 1" Blind

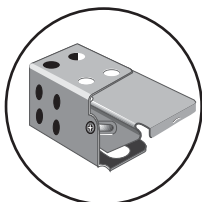
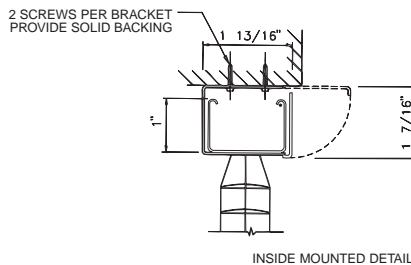
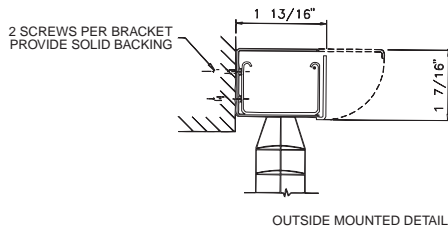
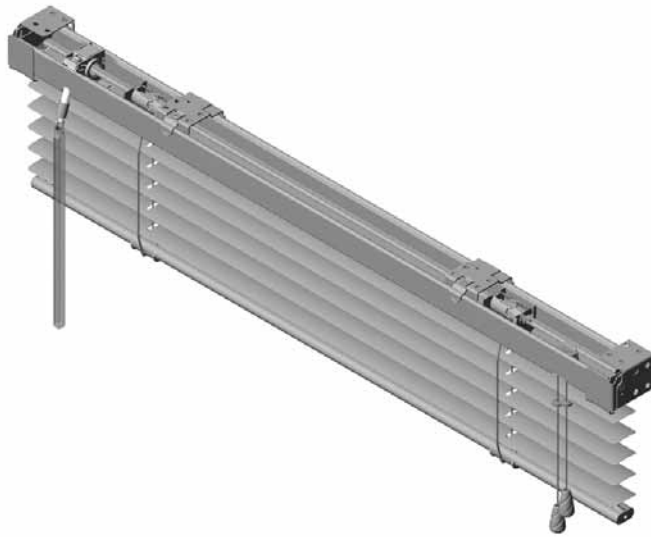

Open End Bracket

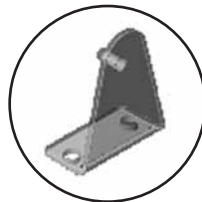

Hold-down Bracket

PRODUCT SPECIFICATIONS

For more detailed specifications please reference Riviera Contract 1" Blind product Guide Specifications.

Part II - Products

A. Riviera Contract 1" Blind manufactured by Levolor

B. Limited Lifetime Warranty

C. Materials:

- Headrail** shall be of .025" thick Tomized steel, "U" shaped, 1" high x 1 1/8" wide. All hardware shall be enclosed in the steel headrail.
- Guardian Tilter** mechanism shall be of a not less than .042" thick Tomized steel housing with a self-lubricating nylon, automatically disengaging worm and gear mechanism to eliminate overdrive.
- Tilt Wand** shall be transparent with a hexagonal cross section 5/16" across flats.
- Cord Lock** shall be .042" thick Tomized steel and shall be crashproof.
- Drum and Cradle** shall be provided for each ladder.
 - a. Drums shall be of .031" thick Tomized steel.
 - b. Cradles shall be of .042" thick Tomized steel.
- Installation Brackets** shall be of at least .048" thick Tomized steel with a rivet-hinged safety locking front cover to permit removal of headrail without lateral movement.
- Ladders** (slat supports): Distance between slats shall not exceed 21.5mm.
- Slats** shall be of 5000 series magnesium aluminum alloy which includes 90% or higher recycled aluminum materials. Slats shall be nominally 1" wide and the thickness of the slats shall be nominally .006".
- Bottomrail** shall be of .023" thick Tomized steel.
- Options** shall include:

a. Cutouts	h. Restrictive Cam Tilter
b. Extension Brackets	i. Ring Pull
c. Hold Down Brackets	j. Telescopic or Non-Telescopic Pole
d. MultiColor Striping	k. Top Lok® Cord Lock
e. Multiple Blinds on One Headrail	l. Universal Ring Tilter
f. Pivot Plates	m. 2 slat unframed valance
g. Projection Brackets	



Levolor
4110 Premier Dr.
High Point, NC 27265

© Copyright 2007 Levolor. All rights reserved. US and non-US patents and patents pending. Product specifications are subject to change without notice. Printed in the USA.

Contract Customer Service
1-800-826-8021
www.levolorcontract.com