



FireMaster® DryerWrap

Datasheet Code US: 7-14-241

MSDS Code US: 350

© 2009 Morgan Thermal Ceramics, a business within the Morgan Ceramics Division of The Morgan Crucible Company plc



1. Product Description

Thermal Ceramics newest fire rated duct wrap product is FireMaster® DryerWrap for application on dryer vent ductwork in multi-unit housing where fire compartmentation and life safety are major concerns. FireMaster DryerWrap is tested and UL Listed for 1-hour fire resistance on 4 inch diameter and 30 gage duct construction penetrating 1-hour rated wood joist gypsum floor therefore providing Owners, Architects, and Engineers a viable and cost effective solution for safely routing dryer exhausts from the laundry room to the exit of the building. At 1 inch thick and 6 pound per cubic foot density, FireMaster DryerWrap is 50% thinner, lighter, and appreciably more flexible than any other alternative fire wraps currently available. The optimized thickness and approved 1 inch compression or overlap joints provide for significant installation cost and space savings.



Product Features

- 1 inch thick, 6 lb per cubic foot density
- High temperature insulation rated for 2100°F continuous exposure
- Underwriters Laboratory tested and Listed per ISO6944 and ASTM E814 (UL1479)
- Fully Encapsulated in scrim reinforced foil facing
- 1 inch compression or overlap at joints allows for installation inside 6 inch space
- Installation using 14 gage galvanized steel tie-wire
- Tested on 30 gage duct, typical of dryer and domestic kitchen range vent construction

Product Benefits

- Optimized installation cost
- Optimized installation space
- Easily to cut
- More flexible than alternative wraps
- Improved safety with application specific testing

2. Physical Characteristics

Length x Width:	300 inches x 20 inches
Thickness:	1 inch
Density:	6 lb. per cubic foot
Encapsulation:	Scrim reinforced foil (FSP)
Packaging:	1 roll per carton
Blanket Weight:	21 lbs.

3. Performance Specification

ISO 6944	1-Hour Rating
ASTM E814 (UL1479)	1-Hour T-Rating
ASTM E814 (UL1479)	1-Hour F-Rating
ASTM E84 -Flame Spread	< 25
ASTM E84 -Smoke Developed	< 50
ASTM E136	Pass
ASTM C518 -R-Value at 70°F	4.9
ASTM D6329 (Mold at 75 R.H.)	Resistant

4. Codes Compliance and Laboratory Listings

2009 IBC Sections 716.6.2, 708, and 703
 2009 IMC Section 504.2 and 604
 UL Listing F-C-7055 for 1-Hour F and T-Rating
 UL Listing HNLJ.V-29 for 1-Hour Ventilation Duct Rating
 ULC Listing FRD 28 for 1-Hour Ventilation Duct Rating

5. Installation

Materials and Equipment

- FireMaster DryerWrap
- 3" Tape (UL 181 Listed and Labeled)
- Serrated knife recommend
- 14 Gage galvanized steel tie-wire
- Wire cutters

Installation: Cut insulation to the length of the duct to be wrapped, and tape seal cut edges using 3" foil tape. For 4" dryer ducts the as supplied 20" width will be sufficient to provide for either a 1" compression or 1" overlap on the longitudinal joint. This long joint may be tape sealed utilizing 3" foil tape at the contractors discretion. Adjacent blankets are installed with either a 1" compression or 1" overlap at the joint between blankets. Utilizing minimum 14 gage tie-wire, cut wire to sufficient length to wrap the insulated duct and make a small loop in one end. Wrap the tie-wire around the insulated duct on maximum 8" centers, passing the wire end through the loop, pulling to hand tight, and crimping the end over on itself to make a permanent hold. Where the insulated duct passes through 1-hour rated floor/ceiling assemblies, the penetration should be framed out and the annular space packed with scrap FireMaster insulation recessed minimum 1/4 inch from top surface. The recesses space shall be filled with a UL Listed firestop sealant per F-C-7055.



FireMaster® DryerWrap

DRYERWRAP FOR 1-HOUR ENCLOSURE OF DRYER VENTS

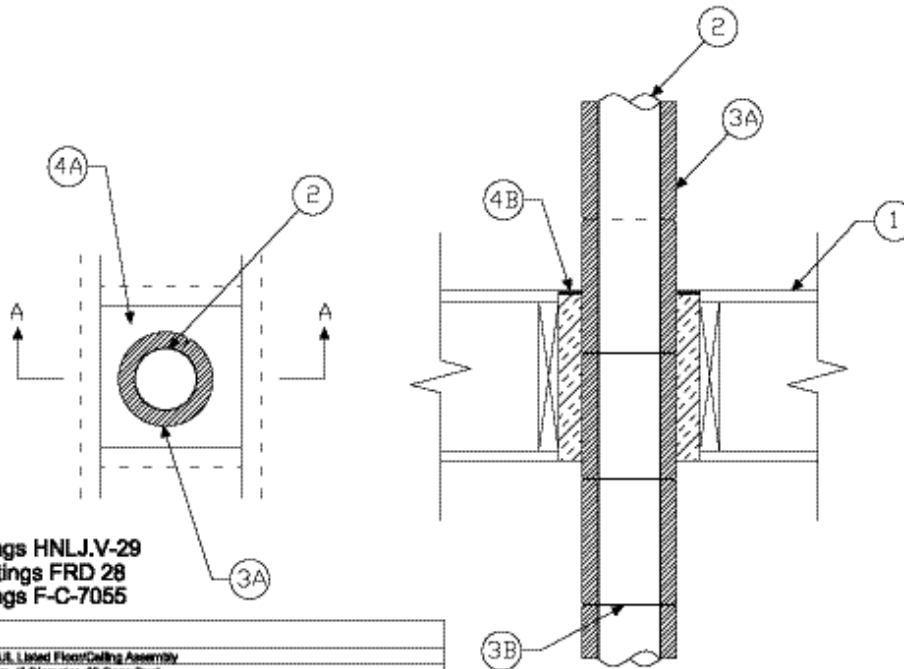

UL Listings HNLJ.V-29
ULC Listings FRD 28
UL Listings F-C-7055

LEGEND	
1	1-Hour UL Listed Floor/Ceiling Assembly
2	Medium 4" Diameter, 30 Gauge Duct
3A	FireMaster DryerWrap with 1" longitudinal and lateral compression or overlap joints
3B	Minimum 14 Gauge galvanized steel tie-wire installed on maximum 8" centers
4A	FireMaster blanket (ball removed) packed into annular space (20% min. compression)
4B	Firestop sealant per F-C-7055 (FireMaster Putty or approved alternative)

The results of FireMaster cut systems is subject to the quality of the products.

SECTION A-A

TESTED ASSEMBLY; EQUIVALENT TO 1-HR F AND T-RATING

