

HANDISWAGE

Atlantis Rail's HandiSwage System is an easy to use cable railing product utilizing fittings that are an adaptation of traditional swage fittings. They can be attached to cable using Atlantis Rail's specific hand swage tools. HandiSwage combines the aesthetic appeal, quality and durability of RailEasy™ cable railing with the convenience and economy of 1/8" cable. The following guide will take you step-by-step through the process of installing your HandiSwage cable system, offering helpful tips and tricks along the way.

Customer Service

(800) 541-6829
(508) 732-9191

Facsimile

(508) 732-9798

Web Address

www.atlantisrail.com

Email

info@atlantisrail.com

Mailing Address

Atlantis Rail Systems
70 Armstrong Road
Plymouth, MA 02360

Tools

Required

- Power Drill
- #2 Phillips Driver Bit
- 9/32" Drill Bit
- 3/16" Drill Bit
- 1/8" Drill Bit
- 7/16" Open Wrench
- 3/16" Open Wrench
- Cable Cutter
- Hand Swager Tool

Recommended

- Hack Saw
- Vise Grips
- Cable Grip Pad
- Carpenters Square
- Chalk Line
- RailEasy™ Drilling Template
- Hammer
- **After Swage Gauge**

Table of Contents

Tools	1
Components	1
Installing the Cable – Straight Sections	
Preparation	2
Installation	2-3
Installing the Cable – Stairs & Ramps	
Preparation	4
Installation	4-6
HandiSwage Specifications	6

HandiSwage Components

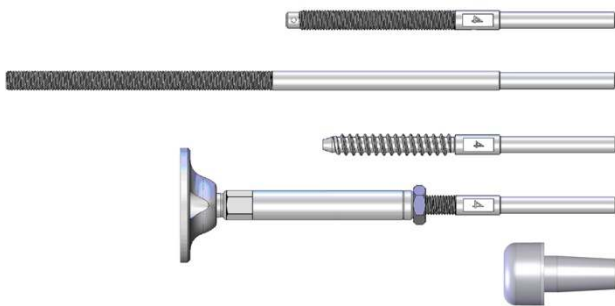

Part Number	Description
S0731-H0703	HandiSwage Standard Stud 1/8" (1/4"-28 RH)
S0731-HL703	HandiSwage Long Stud 1/8" (1/4"-28 RH)
S0747-HR03	HandiSwage Lag Stud 1/8"
S0748-H003	HandiSwage Tensioner 1/8"
S0981-P003	HandiSwage Flush Fitting 1/8"

Additional Components

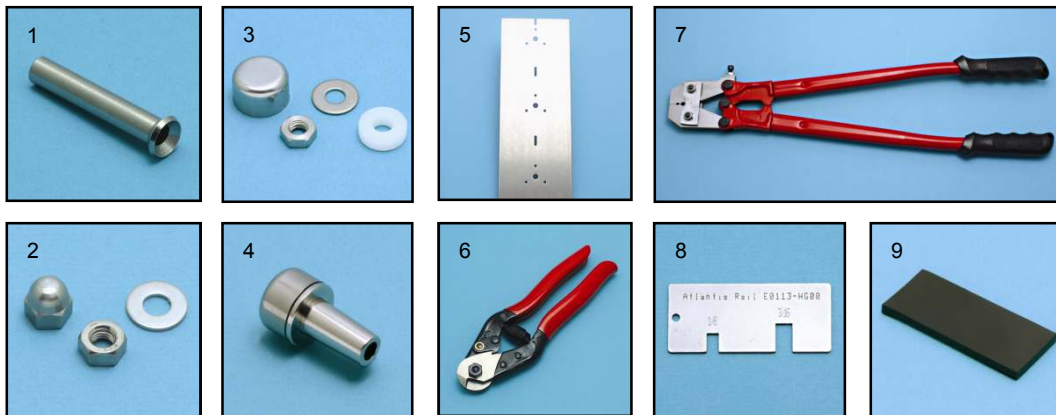

1. HandiSwage Cable Sleeve
2. Acorn Nut Set
3. Deluxe Cover Nut Set
4. HandiSwage Flush Fitting
5. RailEasy™ Drilling Template
6. RailEasy™ Cable Cutter
7. Hand Swager
8. After Swage Gauge
9. Cable Grip Pad

Preparation

Straight Sections

The infill for Atlantis Rail's HandiSwage System is comprised of cable and a variety of hand swage fittings. The following section will show you how to install cable on straight sections of your deck.

Stud Terminals (S0731 Series)

Measure & Mark Your Posts

Determine the number of cable runs you will need to maintain code compliancy. **Check with your local building codes before installing any cable railing system!** Atlantis Rail recommends spacing your cable at 3" O.C. to help avoid any potential building inspection or safety issues. We offer a handy drilling template that is spaced at 3" to help you locate your centers.

Find the center of the post face and draw a vertical line. Measure your spacing up from the surface of the deck to the underside of the railing. Using a carpenter's square, draw lines across the post face making sure they intersect with the center line you just drew (See *Figure A & B*). Repeat for both sides on every post.

For corners you must offset your holes by 1/2" to avoid having the HandiSwage studs interfere with each other or cause a weakened post situation (See *Figure C*).

Drill Your Posts

Using a 9/32" drill bit, drill straight through the end and corner posts. Drilling the posts from each side and attempting to meet them in the middle will help you hit your centers more accurately and will make for a neater installation. Be sure your drill is level and that the hole goes all the way through the post. The swage terminal should be able to pass completely through this hole.

For the mid posts, use a 3/16" drill bit (7/32" if you're using the cable sleeves, S0915-0338) and drill completely through the posts. Again, drilling from either side of the post and meeting in the middle will help you hit your centers and make for a neater installation. The cable will need to run through this hole without kinking or bending.

Flush Fitting Terminal (S0981-P003)

The flush fitting is designed to ease installation by eliminating the need for accurate measurement and swaging at one end of a cable run. When using the flush fitting on one end you will re-drill the back end of the post (See *Figure D*) with a 7/16" bit approximately 1-1/4" deep to accept the flush fitting. See additional instructions below for running cable using the flush fitting.

Installing the Cable

Run The Cable

Beginning at the top, attach the cable to the swage terminal in accordance with the hand swaging tool instructions. It is important to follow the accompanied instructions. **Follow all warnings and wear proper safety equipment when working with cable to prevent injury.**

If you're using the Deluxe Cover Nut Set, place the plastic insert, washer and nut on the end of the shank. Set aside the cover for tensioning later (See *Figure E*). On the other end of the cable run, place another swage fitting in the pre-drilled hole. Once again, if using the cover nut set, switch the tensioning nut out with the cover nut set. Leave the tensioning nut as much travel as possible. Pull the cable tight by hand to the back of the swage fitting. Mark and cut the cable there and remove the swage terminal (See *Figure F*).

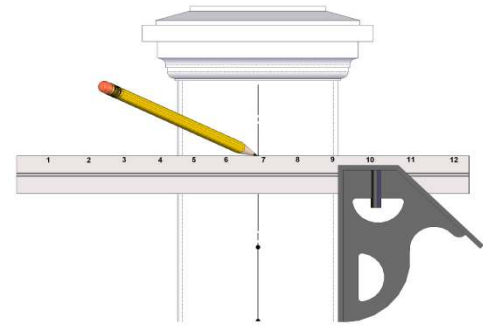

Figure A. Measure and mark both sides of every post at 3" on center.

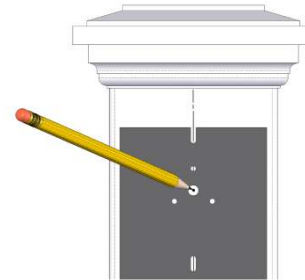

Figure B. Atlantis offers a template to help you find your centers.

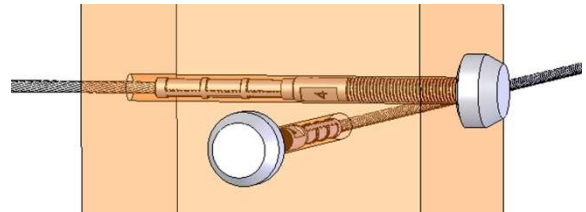

Figure C. For corners, offset your holes by 1/2" to avoid stud interference and/or weakening of posts.

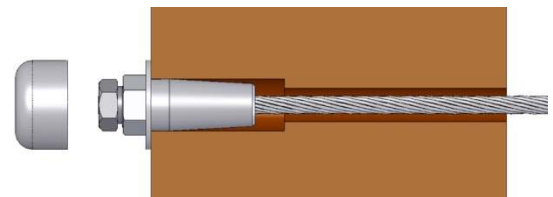

Figure D. Re-drill the back end of the post with a 7/16" bit to accept the flush fitting.

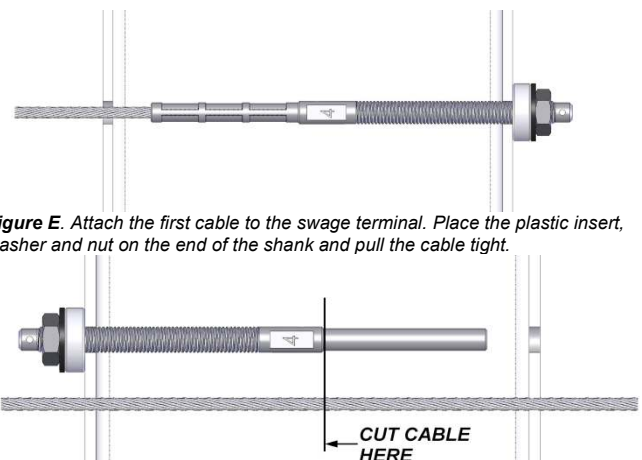

Figure F. Pull the cable tight to the back of the swage fitting. Mark and cut the cable there and swage the second fitting in accordance with swaging tool instructions

Feed the cable through all the mid posts. Follow the swaging instructions again and swage the second fitting onto the cable. Replace the tensioning nut or cover nut set. Repeat the above steps until all the cables are run *before* applying tension.

If using the HandiSwage Flush Fitting:

Measure the entire cable run span plus 1 inch beyond the post at the opposite end and cut your cable to that length. Attach (swage) one end of the cable to the HandiSwage stud. Thread the tensioning nut two (only 2) complete turns and let the tensioning nut rest against the back of the post. Run your cable to the opposite post where you have drilled the post to accept the flush fitting, going through all mid post. At the opposite end put the cable through the end post and through the flush fitting (See *Figure G*). Push the flush fitting against the back of the post and pull the cable tight before finger tightening the outside nut on the flush fitting. TIP: Use a Cable Grip Pad with vice grips at the last mid post to hold cable tension while installing flush fitting (See *Figure H*). Using 3/8" and 7/16" wrenches tighten the flush fitting onto the cable. Return to the opposite end and tighten your HandiSwage stud until there is no slack in the cable. Trim excess cable on the flush fitting with a hack saw or grinding disk (cable must be flush with the flush fitting) and place the stainless cap on the completed flush fitting installation (See *Figure I*). Follow cable tensioning instructions.

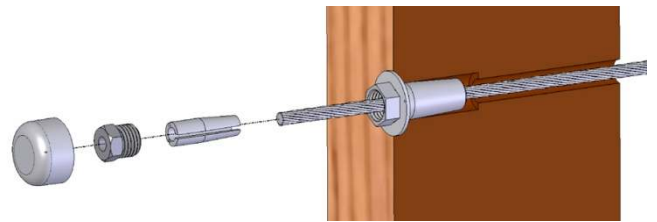

Figure G. Put the cable through the flush fitting. Push it against the back of the post and put the cable tight.



Figure H. Use a cable grip pad with vice grips to hold the cable tight.

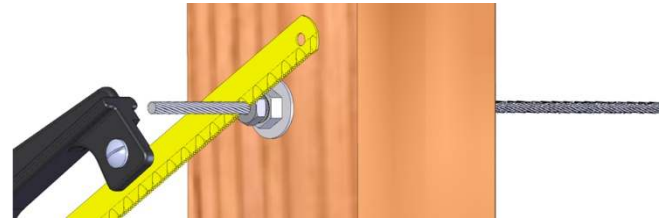

Figure I. Trim excess cable with a hack saw or grinding disk in order to attach the cap for a finished look.

Tensioning the Cable

Straight Sections

Before tensioning any of the cables, **it is important to be sure that the frame for the infill is completed**. Make sure the posts are installed securely and in accordance with the manufacturers' recommended installation procedures. Install all top and intermediate rails. The posts will deflect beyond allowable limits if you attempt to tension the cables on an incomplete guard frame. Before tensioning with tools, hold the stud fittings firm and tension the nuts of the system by hand until all cables are snug.

Stud Terminals (S0731 Series)

General Cable Tensioning

When tensioning cable using a stud of any type, you must hold the stud or cable in a neutral position while turning the nut to apply tension. There are two methods to accomplish this; both requiring a pair of vice grip pliers. **1)** You can hold the back of the swage stud with the vice grips which requires at least 1/4" space between the tensioning nut and the end of the stud (See *Figure J*). **2)** You can use a Cable Grip Pad to hold the cable just outside the post while you tension the stud using the tensioning nut (See *Figure K*). NOTE: using this method requires a HandiSwage Cable Grip Pad, **never clamp pliers or vice grips directly on cable**. Set your vice grips with 1/8" space total between cable and vice grip jaws, Place pad on cable and then apply the vice action to the pliers.

Tension the Center Cable

Beginning with the center run of cable, hold the swage terminal firm using one of the methods described above and tighten the tensioning nut with a 7/16" wrench. Tighten the nut three or four full rotations until cable is snug. **Do not over-tension!** Don't worry if this cable moves a little, we will come back around to it later.

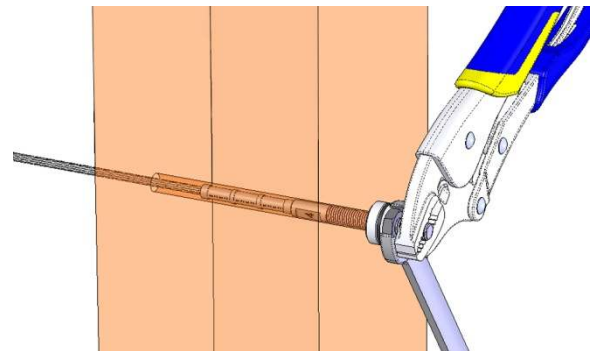

Figure J. METHOD 1: Hold the back of the swage stud with vice grips while tightening the tension nut.

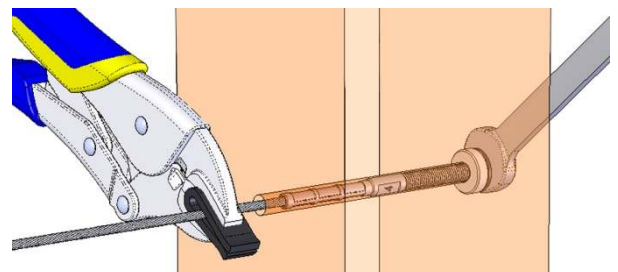

Figure K. METHOD 2: Using a HandiSwage Cable Grip Pad and vice grips, hold the cable in a fixed position while tightening the tension nut.

Tension the Remaining Cables

Alternate tensioning the cables from center, working above and below the center cable as if tightening the lug nuts on a tire (See *Figure L*). Again tension the nuts three or four full rotations or until cable is snug. You will notice as you tension, the cables surrounding it will slacken. When this happens, stop tensioning and move onto the next cable.

Make Final Adjustments

Go back to the center cable and retighten the cables until all are tight and relatively equal in tension. You may find that you need to do this three or four times getting down to even a quarter turn of the tensioning nut each time. Tension from both sides when necessary.

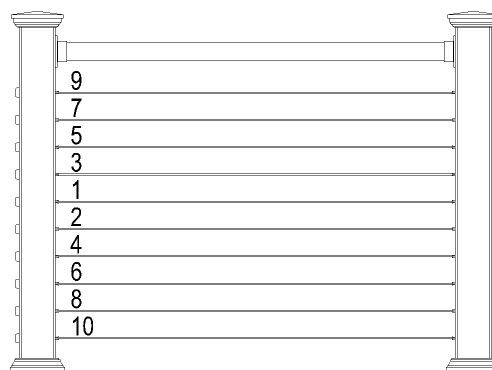

Figure L. Tensioning Diagram – Begin with the center run of cable and alternate working above and below until cables are tight.

Additional Components: Atlantis Rail offers a cable sleeve insert (S0915-0338) for a more finished look for your mid-posts. To install, simply drill your mid posts with a 7/32" drill bit and lightly tap the sleeve in with a hammer.



Install Cover Nuts

With the cables tensioned, it's time to install the cover nuts. This is accomplished in just three easy steps, and you just did one of them! Using a hack saw, cut the remaining shank off flush with the tensioning nut. Then place the cover nut over the assembly until it is flush with the post (See *Figure M*). The plastic insert ensures that the cover nut will have a snug fit and will not come off.



Figure M. The Deluxe Cover Nut Set installs in just 3 easy steps: tighten, cut and cover

Installing Lag Studs

To install the HandiSwage Lag Stud (S0747-HR03), pre-drill the posts with a 3/16" drill bit to a depth of 1-5/8". Crimp the cable in accordance with the swaging tool instructions. Pull the cable the length of its run and cut it a little long. You will need to cut it to length later. Using a 3/16" wrench, turn the lag stud until it is fully seated to the face of the post. **When tensioning the lag stud, make sure that the other end of the cable is free. Twisting the cable severely weakens it and will cause it to fail or break.** When the lag stud is installed (See *Figure N*), finish running the cable using the method prescribed above.

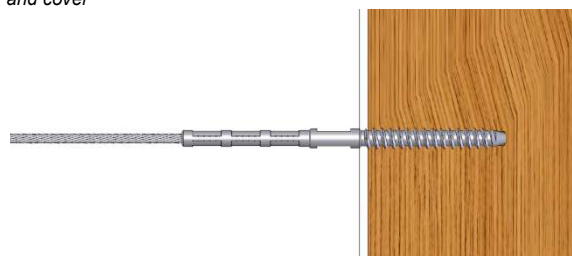

Figure N. Completed Lag Stud Assembly

Preparation

Stairs and Ramps

Atlantis Rail offers a swiveling component to accommodate stairs, ramps, and other angled cable sections. This is the HandiSwage Tensioner (S0748-H003). The HandiSwage Tensioner is installed with three (3) #8 x 1-1/2" wood screws and swivels up to 45 degrees.

Measure & Mark Your Posts

As in the previous section, begin by determining the number of cables you need to maintain code compliancy. **Check with your local building codes before installing any cable railing system!** Atlantis Rail recommends that the distance between cables on stairs and ramps not exceed 3".

As before, find the center of your posts and draw a vertical line. Snap a chalk line parallel to the slope of the stairs at the height of your lowest cable run. Measure for your other cables 3" on center **perpendicular** to that line (See *Figure O*). Snap a chalk line for each cable run.

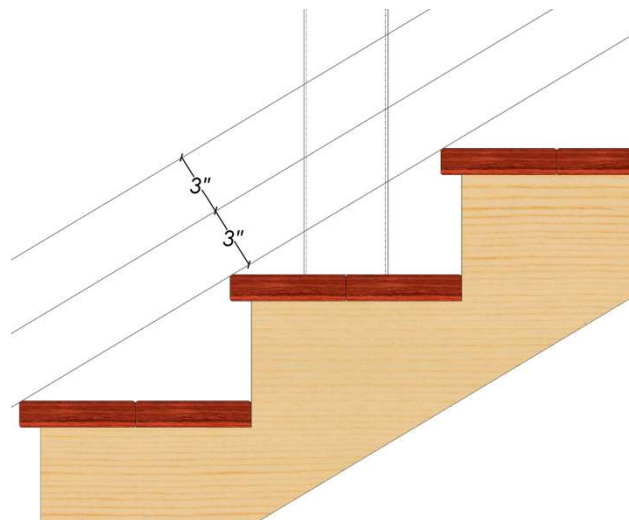

Figure O. Measure perpendicularly from the chalk line to find the center line of your cables

Using a carpenter's square, transfer a line to the inside post face to find the center of your cable (See *Figure P*). Where this line intersects the vertical line is the center point for your cable.

Use Your Fittings as a Guide

On the end posts, place the center of your fittings on the marks made in the previous section. Carefully mark and pre-drill the centers of the fasteners using a 1/8" drill bit. The HandiSwage Tensioner base uses three (3) #8 screws. The drilling template has this hole pattern laid out for ease of use. See below for more information.

Drill the Mid Posts

Carefully drill the mid posts using a 3/16" drill bit. Use a spotter on the side to make sure that the drill is angled properly. It is important to drill the angle correctly to prevent the cable from bending or kinking. There are several drill guide tools commercially available to help you with this task.

Additional Components: Atlantis Rail offers a drilling template to help with the installation of the HandiSwage Tensioner. It has the circular hole pattern of the HandiSwage Tensioner base spaced conveniently at three inches on center to make laying out your cable each.

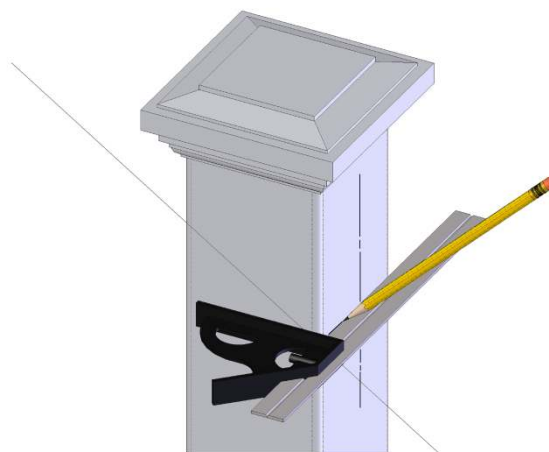

Figure P. Using a carpenter's square, transfer the chalk line to the inside face of the post. The intersection of this line and the vertical will mark your center.

Installing the Cable

Run the Cable

Begin by removing the stud of one end of a cable run and swage it in accordance with the swaging tool instructions. Re-thread the stud into the tensioner body. Leave 3/4" of thread for a section of cable 20 feet or less and an additional 1/4" for every 10 feet thereafter (See *Figure Q*). The maximum span for cable is 50 feet. Extend the stud on the other end of the cable an equal amount. Pull the cable tight to the back of the swage stud. Mark and cut the cable as prescribed above.

Feed the cable through the mid posts. Following the swaging instructions, swage the second fitting onto the cable. Repeat the above steps until all the cables are run *before* applying tension.



Figure Q. Extend the stud leaving 3/4" of thread for 20' or less. For every additional 10', leave another 1/4" of thread exposed.

Tensioning the Cable

Stairs and Ramps

Before tensioning any of the cables, **it is important to be sure that the frame for the infill is completed.** Make sure the posts are installed securely and in accordance with the manufacturers' recommended installation procedures. Install all top and intermediate rails. The posts will deflect beyond allowable limits if you attempt to tension the cables on an incomplete guard frame. Before tensioning with tools, hold the stud fittings firm and rotate the tensioner body by hand until all cables are snug.

Adjustable Terminals

Tension the Center Cable

Beginning with the center run of cable, hold the swage terminal firm using a 3/16" wrench. Using a 5/16" open wrench, rotate the tensioner body to tension the cable (See *Figure R*). Turn the body three or four full rotations until cable is snug. **Do not over-tension!** Don't worry if this cable moves a little, we will come back around to it later.

Helpful Tip: The HandiSwage Tensioner will swivel up to 45°. By turning the tensioner base upside down so that the recess is facing up, you can angle the tensioner upward. Similarly, turn it to the side to run cable on a lateral angle for curved or angled decks.



Figure R. Hold the swage terminal still with 3/16" wrench and using a 5/16" open wrench, rotate tensioner body to tension.

Tension the Remaining Cables

Alternate tensioning the cables from center, working above and below the center cable as if tightening the lug nuts on a tire. Rotate the body three or four full rotations or until cable is snug. You will notice as you tension, the cables surrounding it will slacken. When this begins happening, stop tensioning and move onto the next cable.

Make Final Adjustments

Go back to the center cable and retighten the cables until all are tight and relatively equal in tension. You may find that you need to do this three or four times getting down to even a quarter turn of the tensioner body each time. Tension from both sides when necessary.

Important Note: Make sure when tensioning the cable that you only rotate the body of the tensioner. It is important NOT to twist the cable as you tension. This can cause the cable to snap and is potentially dangerous. Wear appropriate protective gloves and eyewear, and always be aware of your surrounding when working with cable to avoid injury.



HandiSwage Product Specifications

Atlantis Rail's HandiSwage System uses either pre-existing or new railing guards. Recommended posts are nominal 4x4 wood posts. Other materials may be used but at your own discretion. Atlantis Rail does not supply the guard frame for the HandiSwage line of cable infill. Guard frame should be capable of receiving the mounting screws and withstanding deflection under tension. All components in the HandiSwage System are made of grade 316 stainless steel. Working load limit for all hand swage terminals is 60-70% of cable strength.

Components

Product	Description	Dimensions	Fasteners	Notes
S0701-0003-01	1/8" Cable, 100ft. spool	1/8" 1x19 316 stainless steel cable	--	360 lb. WLL
S0701-0003-02	1/8" Cable, 250ft. spool	1/8" 1x19 316 stainless steel cable	--	360 lb. WLL
S0731-H0703	HandiSwage Standard Stud	4.320" length. 1/4"-28 RH thread	--	--
S0731-HL703	HandiSwage Long Stud	8.000" length. 1/4"-28 RH thread	--	--
S0731-HM0703	HandiSwage Short Stud	2.560" length. 1/4"-28 RH thread	--	--
S0747-HR03	HandiSwage Lag Stud	3.847" length. .200 shank width	--	Coarse wood thread
S0748-H003	HandiSwage Tensioner	6.120" length. 1/4"-28 RH thread	(3) #8 x 1-1/2"	Adjustable
C0915-0338	HandiSwage Cable Sleeve	1.500" length. .150" ID, .220" OD	--	Packages of 10
S0981-P003	HandiSwage Flush Fitting	1.330" length	--	--
S0308-UF07-R	Acorn Nut Set	.674" complete assembly	--	1/4"-28 RH thread
S0307-UF07-R	Deluxe Cover Nut Set	.400" length. .750" OD	--	1/4"-28 RH thread
E0113-H600	Hand Swager	--	--	--
E0113-HG00	After Swage Gauge	--	--	--
C0988-1000	RailEasy™ Drill Template	--	--	3" on center
C0989-00HD	RailEasy™ Cable Cutter	--	--	--
E0114-0000	Cable Grip Pad	--	--	Packages of 3