

## What You'll Find In This Brochure:

- Door Identification
- Door Inspection
- Storage and Handling
- Field-Finished Wood Veneer Doors
- Factory-Finished Wood Veneer Doors
- High Pressure Decorative Laminate Doors
- Acoustical Doors
- Exterior Doors
- Installation Guidelines (negative pressure)
- Field Fitting Doors
- Door Tolerances
- Installation Instructions for Fire-Rated Wood Glazing Kits
- Installation Instructions for Non-Rated Wood Glazing Stops
- Installation Instructions for Metal Vision Panels
- Astragals and Edge Sets (Channels)
- Installation Instructions for UL 10C Door Assemblies (positive pressure)
- How to Read VT Door Labels (New Albany)
- How to Read VT Door Labels (Holstein)

**VT Industries, Inc.** provides architectural grade interior wood doors that have been manufactured in accordance with customer requirements, as well as WDMA, AWI, WI & AWMAC quality standards for flush wood doors and stile and rail doors. The following are guidelines for those working with our products on the jobsite. Please take a few minutes to read through all information to ensure customer satisfaction. Contact VT's Customer Service Center at 1-800-827-1615 with any questions or concerns regarding your VT doors.

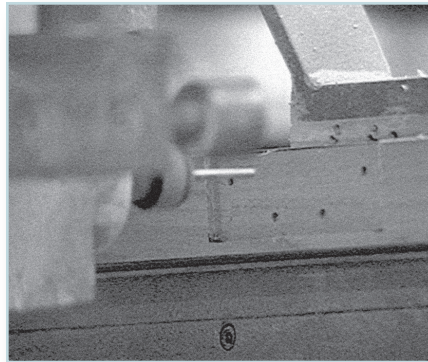
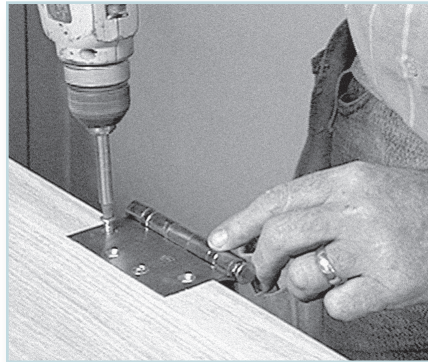

Please take a few minutes to read through all information to ensure customer satisfaction.

# VT Field Guide

## Door Identification:

VT doors are identified by a permanently affixed label on the top rail of each door. Fire labels are placed on the hinge stile, unless hardware prohibits it; in that case, the fire label will also be placed on the top rail. Should you have a question regarding one of your doors, please refer to the door information on the top rail before calling the factory. This will allow our Customer Service Representatives to assist you more easily. See back page for example ID label. **DO NOT REMOVE ID LABELS FROM DOORS.**

## Door Inspection:

- 1 Inspect all doors for freight damage immediately upon receipt. Note identification numbers of any damaged doors on delivery ticket before signing. Failure to do so may result in refusal of claim.
- 2 All doors should be inspected for manufacturing flaws prior to field finishing and/or installation. Any claims must be made prior to hanging doors.
- 3 Upon receipt of any claims, VT will acknowledge in writing to assure prompt evaluation and handling.

## Storage & Handling:

- 1 Doors must always be stored flat and in clean or dry surroundings. Protect from dirt, water, and abuse.

- 2 Doors shall not be exposed to excessive moisture, heat, dryness, or direct light. Protect the entire face of the door from light to avoid color changes to portions of the face. **Buildings where humidity and temperature are controlled provide the best storage facilities (recommended conditions are 30-50% Relative Humidity and 50-90° F).**
- 3 Doors must always be handled with clean hands or while wearing clean gloves.
- 4 Doors must be lifted and carried, not dragged across one another.

## Field-Finished Wood Veneer Doors:

*Field finisher is completely responsible for finished appearance of wood doors or panels. VT warranty does not apply to appearance of field-finished doors. The following recommendations are made to assist the field finisher.*

- 1 Prior to finishing, ensure that the building atmosphere is dried to a normal, interior relative humidity. Ensure that the doors have been allowed to equalize to a stable moisture content.
- 2 **Prior to finishing, remove all handling marks, raised grain and other undesirable blemishes by completely block or power sanding all surfaces with a 100-150 fine-grit sandpaper. Place doors in a horizontal position and sand with the grain of the wood. If any undesirable reactions or problems arise, stop finishing and notify your door supplier immediately.**
- 3 Certain species of wood, particularly oak, contain chemicals which react unfavorably with certain finishes causing dark stain spots. Where possible, the species/finish combination should be tested prior to finishing the doors. **Notify your finish supplier or door supplier immediately if any undesirable reaction is noticed.** Do not continue with the finishing until the problem is resolved.
- 4 In order not to induce warpage, avoid dark stains or dark-colored paints on door surfaces. Exposure to sunlight or artificial Light can cause warpage.
- 5 In order to prevent blemish magnification, avoid extremely dark stains on light-colored wood species.
- 6 Top and bottom rails are factory sealed on all Heritage flush wood doors. No additional sealing is required unless field-trimmed in height.
- 7 To achieve the desired results of color uniformity, finish build, gloss, and to reduce the frequency of refinishing, obtain and follow finish manufacturer's recommendations.
- 8 Be sure the door surface being finished is satisfactory in both smoothness and color after each coat before you apply the next coat.
- 9 **NEVER REMOVE FIRE LABEL FROM THE HINGE STILE OF A DOOR.**

## Factory-Finished Wood Veneer Doors:

VT's factory finishes envelopes every wood veneer door in a shield of protection even stronger than used on wood flooring. Our Heritage Collection uses a UV cured water-based factory finish system to meet WDMA TR-8 and AWS System 9 is standard. VT's Artistry Collection uses an AWS System 2 Pre-catalyzed lacquer finish. With both collections, there are unlimited stain color options available. With many of the restrictions placed on jobsites today, VT's factory finishing can relieve the stress of finding a local site where field finishing can take place safely and satisfactorily.

VT's wood veneer doors are manufactured using "A" or "AA" grade wood veneers, unless otherwise specified. One consideration when working with wood veneer doors, however, is that wood is a product of nature; and, as such, varies in appearance. Certain color variations or markings are inherent to particular wood species and cannot be hidden by staining. For normal cleaning and maintenance, wipe doors with a clean, damp cloth using a mild detergent. Furniture polishes are not recommended due to waxy build up over time. Likewise, abrasive cleaners or utensils should not be used.

## HPDL Doors:

Laminate manufacturers require certain laminate finishes be supplied with protective peel coats. VT is not responsible for the removal of peel coats from laminate doors. For normal cleaning and maintenance, wipe the laminate with a clean, damp cloth or sponge using a mild soap or detergent. General purpose cleaners such as PineSol™, Fantastic™, or Lestoil™ may also be used. Abrasive cleaners or utensils should not be used on conventional laminate doors since the laminate could easily be damaged.

## Acoustical Doors:

VT's acoustical (STC) doors are fabricated 1-3/4" thick and require a standard 1-15/16" rabbetted doorframe. Acoustical HPDL doors will receive either painted or stained stiles to match or complement the door face; this allows for minor adjustments when field fitting since a snug fit is crucial for maintaining the acoustical rating.

## Exterior Doors:

**Although not warranted by VT, the following precautions should be taken to extend the life of exterior doors.**

- 1 Apply the sealer, primer or first coats of the required finish on exterior doors immediately after fitting, cutting for hardware, weather-stripping, etc., and before the installation of any hardware.
- 2 Metal flashing should be used to protect the top rail from excessive moisture.
- 3 When lite or louver cutouts are made for exterior doors, they must be protected in order to prevent water from entering the door core. Metal flashing at the bottom of the cutout is one satisfactory method.
- 4 Most finishes on exterior doors deteriorate relatively quickly. In order for exterior doors to continue receiving the protection required, inspect the condition of exterior finishes at least once a year and refinish as often as needed to maintain the protective integrity of the finish.

# VT Installation and Maintenance

## Installation:

- 1** The utility or structural strength of the doors must not be impaired in fitting to the opening, in applying hardware or in preparing for lites, louvers or plant-ons or other detailing.
- 2** Use a minimum of one hinge for each 30" of door height on all solid core doors. When using three or more hinges, they are to be equally spaced.
- 3** Clearances are maximum 1/8" at top, at hinge and at lock stiles. Refer to NFPA 80, latest edition, for bottom clearances. All hardware locations, preparations for hardware, and methods of hardware attachment must be appropriate for the specific door construction. Templates for specific hardware preparation are available from hardware manufacturers, WDMA, or DHI.



## Field Fitting Doors:

For best results, doors should be ordered prefit and premachined from the factory. However, in instances where doors need to be field fit, please follow these guidelines:



**Non-Rated Doors** – A minimum 3/4" rail material should be left indoors. Doors may be ordered with wider rails for adjustments on the jobsite. Seal any and all field-cut edges.

**Fire-Rated Doors** – These doors may be trimmed slightly at the bottom rail. Most required machining must be performed by VT or a licensed machiner of VT fire-rated doors. Refer to NFPA 80, latest edition, for more specific information regarding jobsite preparation of fire-rated doors.

**Surface-Applied Hardware** – Special blocking is recommended for use with surface-applied hardware if through-bolts aren't utilized. In cases where no through-bolting is allowed, hardware should be installed with wood screws, and pilot holes must be drilled prior to installation. DO NOT use self-tapping or combination wood/metal screws.

## Door Tolerances:

**Show-Through (Telegraphing)** – Considered a defect when the face of the door varies from a true plane in excess of 0.010" in any 3" span. Glossy laminates or finishes should be avoided because they tend to accentuate natural telegraphing.

**Warp** – Any distortion in the door itself; not measured in relation to the frame in which it is hung. Warp is measured by placing a straight edge or a taut string on the concave face and determining the maximum distance from straight edge or string to door face. For more information regarding door tolerances, refer to the VT Standard Door Warranty.

## General Maintenance:

- 1** Ensure that doors continue to swing freely, do not bind in the frame and that all hardware remains functional.
- 2** Using wedges to hold open doors may result in damage to the door face. More importantly, wedging fire doors open is a life safety issue and a code violation. Damage caused by the use of wedges is not covered under VT's warranty, and VT is not responsible for the illegal use of wedges or other items to hold open fire doors.



# Installing VT Glazing and Edge Sets

## Installation Instructions for Fire-Rated Wood Glazing Kits:

All doors manufactured at the Holstein facility will require the use of fireclips. Only 20-minute fire rated doors manufactured at the New Albany facility will require the use of fire clips.

**Glass Stops:** 3/8" minimum thickness, overlay, or flush moulding (beads).

All fire doors with lites manufactured with woodstops in the Holstein manufacturing facility will require the use of fire clips. Only 20-minute fire rated doors with lites manufactured with woodstops in the New Albany manufacturing facility will require the use of fire clips.

**Glazing:** Install with fire clips, length and width of glass to be 1/4" less than opening. Glass to be of approved, fire-rated, 1/4" glass. Clips must be installed a maxi-

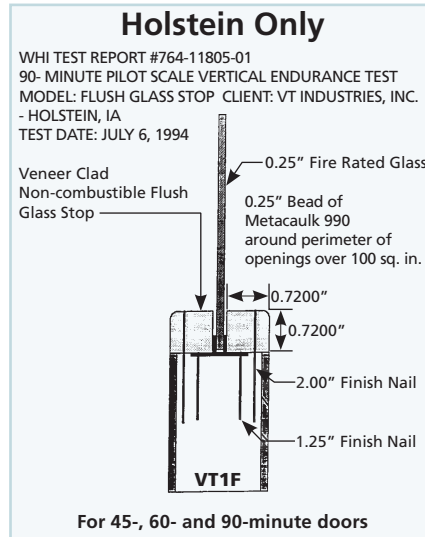

\*NOTE: Wood beads for use on VT's 5-ply wood veneer mineral core doors (45-, 60- and 90-minute) are made of an incombustible material, veneer wrapped to match the wood veneer door face. Not for use on HPDL doors.

mum of 12" apart and be within 6" of the corners. Openings of 6" or less will require only one clip to be installed in the center of the opening. Mouldings or wood beads to be sealed with glazing tape or silicone caulk.

**Clip Installation:** Install base of clip around perimeter of opening at approved intervals with 18-gauge staples or 4d nails. A recess has been cut into doors for placement of fire clips with flush wood beads at the factory. Install glass in the opening and—using a putty knife—slide in the T-shaped half of clip so that it holds the glass firmly and locks into the other half of the fire clip. Secure second side to frame with 4d nails. Apply 1/16" glazing tape, latex, or silicone caulk to the edge of the wood

moulding (bead) and install the moulding with 4d finishing nails a maximum of 2" from each end and a maximum of 12" between nails.

## Installation Instructions for Non-Rated Wood Glazing Stops:

Flush wood beads for non-rated doors will be affixed on one side and lightly tacked into place on the other side of lite cutouts. The only difference when working with non-rated doors is that the use of fire clips is not required.

## Installation Instructions For Metal Vision Panels:

Metal vision panels are only installed at the factory when factory-installed glazing is specified. Follow manufacturer's instructions to install vision panels on the jobsite.

## Astragals and Edge Sets (Channels):

The use of metal astragals or channels on fire-rated doors is determined by local codes, door construction, door size, and hardware. Please refer to the specific requirements for your project to determine whether doors should receive astragals or channels. Astragals and channels will not be installed at the factory. All accessories (vision panels, astragals, etc.) are warranted for one year from date of original shipment.

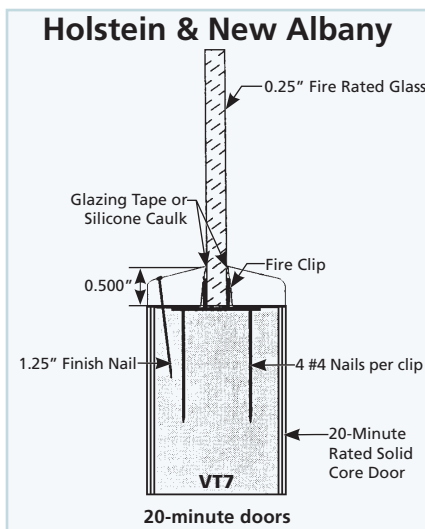

# Positively VT

## Positive Pressure Installation Instructions For Doors That Have Been Labeled in Compliance with UL 10C

VT positive pressure fire doors are constructed to meet Intertek/Warnock Hersey Category A guidelines, allowing doors to be hung without any surface-applied intumescent. Our positive pressure fire doors arrive ready-to-hang, just like all other VT doors. The VT label is your assurance for one-step installation.

- 1 In order to meet the smoke requirement,** a smoke seal, listed and labeled for UL 10C positive pressure installations, must be mounted around the perimeter of the frame.
- 2** Astragal sets, metal edges, or edge guards will not be allowed on VT positive pressure fire doors due to concealed intumescent within the door structure. Flat bar astragals (FBAs) will be allowed on pairs of fire doors.
- 3 Lite Kit** – [Where applicable] install a lite kit listed and labeled for UL 10C positive pressure applications to meet the appropriate fire rating. (See fire label located on door for fire rating.) Follow lite kit manufacturer's instructions for proper installation.
- 4 Frame** – Doors must be installed in fire-rated frames. Standard 3-sided steel frames (minimum 16-gauge) do not require special fire testing for positive pressure. Frames must be installed plumb, square and level.
- 5 Hardware** – Doors have been factory-prepared to receive hardware as indicated by the hardware supplier's schedule. Hardware may be required to be listed and labeled in accordance with UL 10C for use in positive pressure fire-rated wood doors if located above 40" AFF. Anything below 40" AFF can follow existing standards.
- 6 Clearances** – The clearances between the door edge and frame must be at least 1/16" and no greater than 1/8" at the head and jamps. See NFPA 80, latest edition, for clearance under bottom of door.

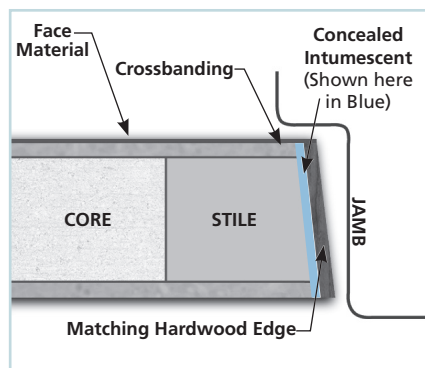

The VT label is your assurance that doors meet positive pressure requirements.

Construction and hardware approvals are continually updated. Call VT at 1-800-827-1615 for the most current information.

# Reading VT Heritage Stile & Rail Door Labels

When referring to a Heritage Stile & Rail door supplied by VT manufactured in the New Albany facility, it is best to look at the top rail of the door for a permanently affixed adhesive label, which will provide all necessary information for that particular door. In our ongoing effort to provide more complete information, some changes have been made to our door label as illustrated below.

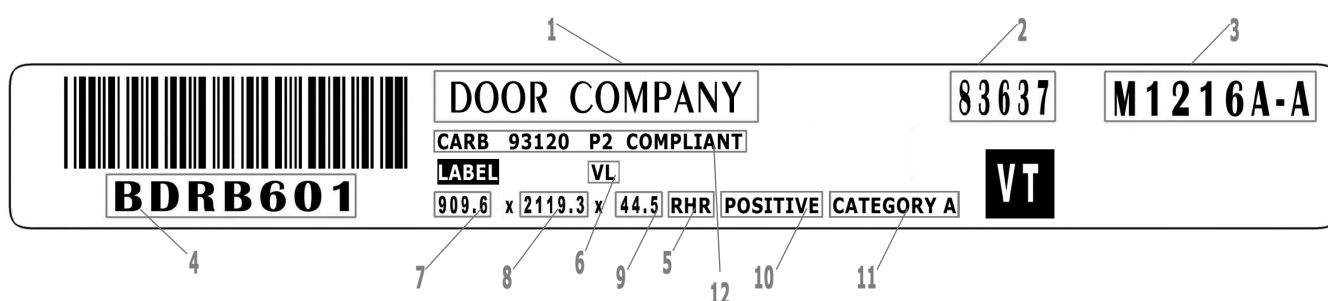

- 1 = Customer Name
- \* 2 = Shop Order Number
- \* 3 = Door Number
- \* 4 = Bar Code Serial Number
- 5 = VT Door Type
- 6 = Fire Rating information. 'WH' = Warnock Hersey. Fire ratings indicated in Roman numerals, XX = 20-minute, VL = 45-minute, LX = 60-minute, and XC = 90-minute. 'PP' indicates positive pressure; 'HM' or 'AL' (frame material on positive pressure doors).
- 7 = Door Width in millimeters
- 8 = Door Height in millimeters
- 9 = Door Thickness in millimeters
- 10 = Positive pressure
- 11 = Indicates Category A compliance under UL 10C
- 12 = CARB Compliant Phase 2

\*When contacting the factory, refer to either Items 2 (shop order number) and 3 (door number) together; or Item 4 (bar code serial number).

VT DOOR IDENTIFICATION LABELS ARE TYPICALLY LOCATED ON THE TOP RAIL OF EACH DOOR AND SHOULD NOT BE REMOVED. THESE LABELS PROVIDE ALL INFORMATION ON HOW DOORS WERE CONSTRUCTED. WARRANTY IS VOID ON ANY DOORS THAT HAVE IDENTIFICATION LABELS REMOVED.

## Service:

VT's Customer Service Center is available to answer questions. You may contact the service representative named on your packing slip by calling 1-800-827-1615 or by faxing 1-712-368-4111.

# Reading VT Heritage Door Labels

When referring to a door supplied by VT, it is best to look at the top rail of the door for a permanently affixed adhesive label, which will provide all necessary information for that particular door. In our ongoing effort to provide more complete information, some changes have been made to our door label as illustrated below.

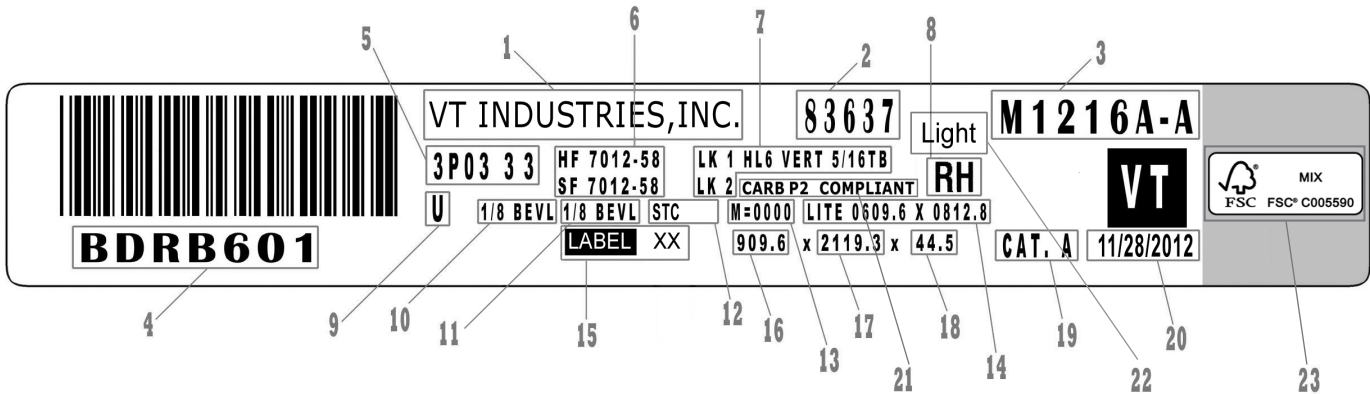

- |   |   |
|---|---|
| <ul style="list-style-type: none"> <li>1 = Customer Name</li> <li>* 2 = Shop Order Number</li> <li>* 3 = Door Number</li> <li>* 4 = Bar Code Serial Number</li> <li>5 = VT Door Type</li> <li>6 = Face Material by color code<br/>(HF = hinge face; SF = stop face)</li> <li>7 = Lock Type</li> <li>8 = Swing of the door</li> <li>9 = Pair Indicator (P = sequence-matched<br/>single doors or door/transom combinations;<br/>A = active leaf of single egress pair;<br/>I = inactive leaf of single egress pair;<br/>D = double egress pair; U = unequal pair;<br/>S = sliding doors; B = bi-fold doors)</li> <li>10 = Bevel Code on the hinge stile</li> </ul> | <ul style="list-style-type: none"> <li>11 = Bevel Code on the lock stile</li> <li>12 = STC Rating</li> <li>13 = Sequence matching</li> <li>14 = Lite Cutout in millimeters (width x height)</li> <li>15 = Fire Rating information. 'WH' = Warnock<br/>Hersey. Fire ratings indicated in Roman numerals,<br/>XX = 20-minute, VL = 45-minute, LX = 60-minute,<br/>and XC = 90-minute.</li> <li>16 = Door Width in millimeters</li> <li>17 = Door Height in millimeters</li> <li>18 = Door Thickness in millimeters</li> <li>19 = Indicates Category A compliance under UL 10C</li> <li>20 = Production Completion Date</li> <li>21 = CARB Compliant Phase 2</li> <li>22 = Stain Tone</li> <li>23 = FSC Label</li> </ul> |
|---|---|

\* When contacting the factory, refer to either Items 2 (shop order number) and 3 (door number) together; or Item 4 (bar code serial number).

VT DOOR IDENTIFICATION LABELS ARE TYPICALLY LOCATED ON THE TOP RAIL OF EACH DOOR AND SHOULD NOT BE REMOVED. THESE LABELS PROVIDE ALL INFORMATION ON HOW DOORS WERE CONSTRUCTED. WARRANTY IS VOID ON ANY DOORS THAT HAVE IDENTIFICATION LABELS REMOVED.

## Service:

VT's Customer Service Center is available to answer questions. You may contact the service representative named on your packing slip by calling 1-800-827-1615 or by faxing 1-712-368-4111.

P.O. Box 490 • 1000 Industrial Park • Holstein, Iowa 51025  
800-827-1615 • Fax 712-368-4111 • [www.vtindustries.com/doors](http://www.vtindustries.com/doors)