

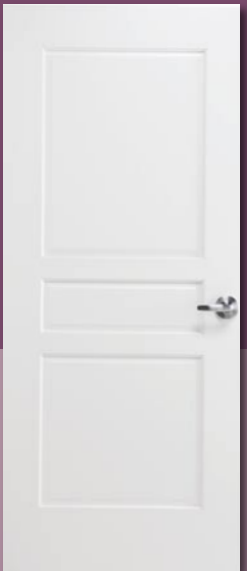

ARCHITECTURAL WOOD  
**DOORS**

PRODUCT OFFERING



# VT INDUSTRIES

VT Industries designs and crafts the finest flush wood veneer, stile & rail, profiled and high pressure decorative laminate (HPDL) doors available for commercial interiors. As an industry leader, we understand that superior products must be coupled with impeccable customer service. That's why your needs are always our foremost concern. You can be confident we will answer your questions, address your concerns and deliver your product on time and to your exact specifications. You're our number one priority. That's the VT difference.

*Doors featured on cover (left to right): SS1021 Mahogany Stile & Rail Door; Quarter Sliced Figured Sapele, Clear Finish; FS1031 Profiled Door; Laminate Flush Door with Wilsonart® 4766-60 Brushmore Mineral*

*Doors featured above (left to right): Plain Sliced Cherry, Clear Finish and SS1041 Plain Sliced White Maple Stile & Rail Door, Clear Finish*

# CONTENTS

## TABLE OF CONTENTS

- 03 Customer Service
- 04 Environmental Considerations
- 05 Flush Wood Veneer Doors
- 07 High Pressure Decorative Laminate Doors
- 09 Stile & Rail Doors
- 11 Profiled Doors
- 13 Permaguard™ Factory Finish System
- 14 VT Color Choices
- 15 Affordable Options from VT
- 16 Wood Door Jambs
- 17 Fire-Rated Doors
- 18 Life Safety
- 19 Excellence in Construction
- 21 Specification Chart
- 23 Stile & Rail Standard Elevations
- 25 Stile & Rail Component Dimensions
- 26 Profiled Door Elevations





VT CUSTOMER

# SERVICE

## CUSTOMER SATISFACTION IS OUR FINEST PRODUCT.

- VT sales and project management personnel are factory trained and provide architectural consultations as part of our customer service standard.
- VTonline® estimating and order entry assures accuracy and reduced lead times.
- Expanded Web site at [www.vtindustries.com/doors](http://www.vtindustries.com/doors) affords architects with up-to-date product, technical and specification information.
- Regular communication with customers throughout the process assures complete and on-time delivery.
- We work to meet customized service requirements, including special sorting instructions, multiple shipments and more.
- AIA/CES training modules provide architects with the most current door construction methods, building codes and life safety information.
- Call our architectural hotline at 800.827.1615 ext. 345 for assistance with your wood door needs.



ENVIRONMENTALLY FRIENDLY

# DOORS

## OUR COMMITMENT TO THE ENVIRONMENT.

- All of VT's particleboard core flush wood doors can be made of recycled/recovered fiber content in order to considerably reduce the environmental impact.
- VT's stave lumber core (SLC) flush wood doors can be made with FSC-certified material.
- VT's agrifiber core flush wood doors are made of rapidly renewable content in order to considerably reduce the environmental impact.
- Our products can assist in achieving environmental credits, including LEED points and SPiRiT.
- VT high pressure decorative laminate (HPDL) and 5-ply wood veneer doors are listed on the GREENGUARD Product Guide™ for low emitting products.
- VT stile & rail doors can also assist with achieving LEED points.

<i>Recycled Content</i>	<i>FSC-Certified</i>	<i>Rapidly Renewable</i>
<i>Particle Core</i>	<i>Stave Core</i>	<i>Agrifiber Core</i>
<i>4 points*</i>	<i>4 points</i>	<i>6 points*</i>

*\* Potential assistance based on LEED NC 2.2.*

With VT flush wood and stile & rail doors, you don't have to sacrifice beauty to protect the environment. VT Doors are manufactured in a highly efficient, environmentally friendly facility. VT Industries architectural wood doors are the only GREENGUARD Certified® wood doors available. They are also available with FSC-certified core and are listed on GreenSpec®.



Environmentally friendly core



Plain Sliced Red Oak, Clear Finish



## FLUSH WOOD VENEER

# DOORS

### NATURAL ELEGANCE. SEAMLESS CONSTRUCTION.

VT 5-ply wood veneer doors provide a stylish solid wood appearance with an upscale European edge design. Our matching hardwood outer stile provides impressive durability and seamless beauty. It's this attention to detail that sets us apart from our competition. When combined with our overall capabilities, product quality and extra standard features, it makes VT the obvious choice for your wood veneer door needs.



### THE VT ADVANTAGE

- Double hot press technology provides consistent quality with Type I glue for a uniform bond between all components.
- Matching hardwood stile edge as standard at no extra cost.
- Matching hardwood edge applied after beveled core assembly results in seamless wood appearance.
- European edge design eliminates unsightly crossbands.
- Withstands the 1 million cycle-slam test (in accordance with WDMA TM-7).
- 5-ply construction.
- Meets positive pressure fire ratings: 20-, 45-, 60- and 90-minute.
- Lifetime warranty.

### DESIGN

- WDMA Premium Grade as standard.
- Selected for uniformity.
- Popular species in stock for faster turnaround times.
- Full range of domestic and exotic species available.
- WDMA System TR-6 catalyzed polyurethane water-based factory finishing.

### HOW TO SPECIFY:

*Composite crossbands shall be applied to core prior to application of matching hardwood stiles. Exposed crossbanding is not allowed along stile edges.*



Plain Sliced Select White Maple, Clear Finish

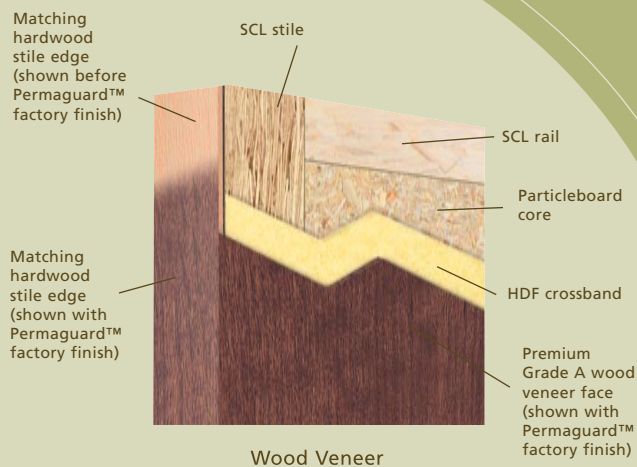



## HIGH PRESSURE DECORATIVE LAMINATE

# DOORS

### THE AFFORDABLE, ARCHITECTURAL ALTERNATIVE.

Value, durability and design freedom. It's what you demand from any architectural wood door. And when you need an affordable alternative to wood veneer, it's precisely what our decorative laminate doors provide. They require no on-site staining, sealing or painting and the costs of maintenance are minimal. For consistent pricing and availability, nothing compares to VT laminate doors.

### THE VT ADVANTAGE

- Preferred hot press 5-ply construction forms a superior bond between all components.
- Laminate edges applied before face minimize the appearance of seams.
- Easy maintenance and stain resistance.
- Vertical grade high pressure decorative laminate as standard provides enduring beauty in any application.
- Edge-before-face design locks in durability and reduces chipping.
- Meets positive pressure fire ratings: 20-, 45-, 60- and 90-minute.
- Lifetime warranty.

### DESIGN

- Affords ultimate consistency throughout the entire project.
- The best choice for a highly uniform wood grain appearance.
- Full array of patterns, solid colors and wood grain laminates to complement any interior.
- Edge-before-face construction affords a desirable solid appearance.
- Ask about silk screen and graphic image custom laminate designs.

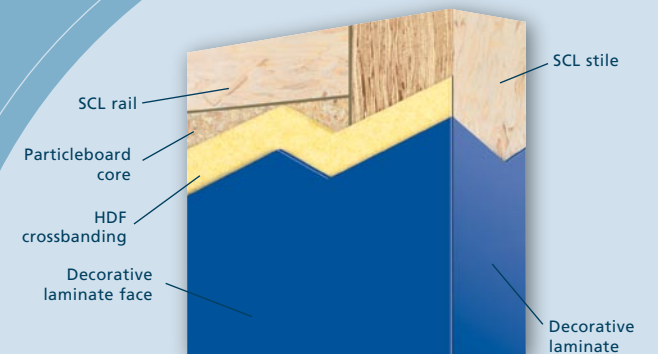

High Pressure  
Decorative Laminate  
5-ply construction shown, 3-ply construction available

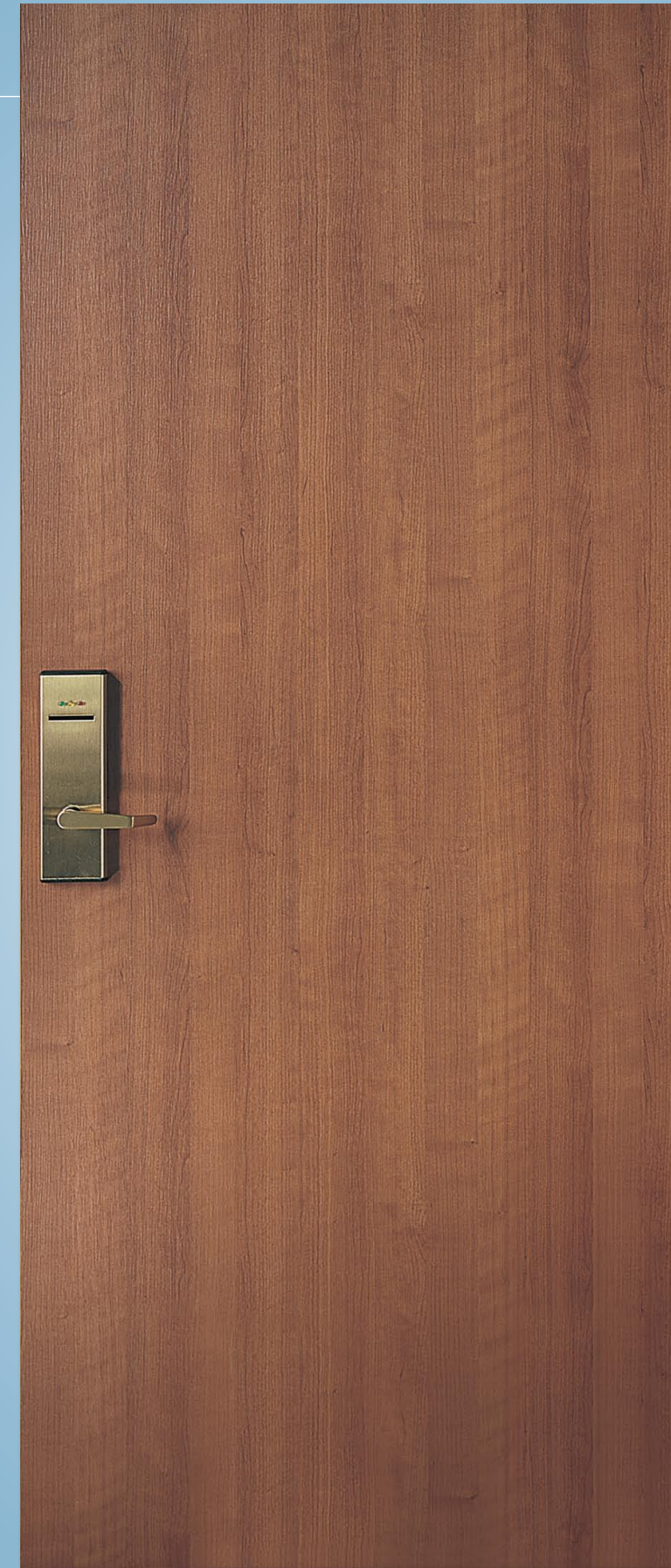

### HOW TO SPECIFY:

*Stiles are to be edged with high pressure decorative laminate prior to face laminates.*

*HPDL to be vertical grade and hot-press-applied.*

*Require factory-sealed top and bottom rails.*



## STILE & RAIL

# DOORS

### THE PERFECT COMPLEMENT TO OUR FLUSH WOOD VENEER DOORS.

Whatever your needs for architectural wood doors, you require only one manufacturer. VT stile & rail doors — guaranteed to provide the highest quality, aesthetic compatibility and design integrity. Not to mention all of the outstanding features you've come to expect from VT.

### THE VT ADVANTAGE

- State-of-the-art production facility and equipment.
- Raised and flat panel door elevations.
- Ovolo, ogee or square sticking choice.
- Manufactured using doveled construction for maximum performance.
- Factory-machined to exacting requirements for hardware, including pre-drilled pilot holes for hinges and face plates.
- Doors individually packaged for maximum protection.
- Matching hardwood edges.
- Fire-rated doors meet positive pressure standards.

### DESIGN

- Doors meet WDMA I.S. 6-A Custom Grade quality standards.
- Five year warranty for interior applications.
- Popular veneer species in stock for faster turnaround times.
- Full array of domestic and imported hardwoods.
- WDMA TR-6 catalyzed polyurethane factory finish to match VT flush wood doors.
- Sealed top and bottom rails on factory finished doors.



#### HOW TO SPECIFY:

*Stile & rail doors to be factory-finished to match flush doors.*

*All architectural doors supplied from the same manufacturer.*

*Require factory-sealed top and bottom rails.*

## PROFILED

# DOORS

### THE AESTHETICS OF STILE & RAIL AT A VALUE.

VT Industries' profiled doors provide the appearance of stile & rail doors in a more cost-effective option. Perfect for projects such as hotels and hospitality, educational facilities and multi-family housing.



### THE VT ADVANTAGE

- Nine standard elevations.
- Four routing profiles.
- MDF core.
- HDF face.
- SCL inner stiles and rails.
- Hardwood outer stiles.
- Doors are primed as standard.

### DESIGN

- Face dimensions:
  - Stiles 6"
  - Top rail 6"
  - Bottom rail 10"
  - Intermediate rails 4" or 6"
  - Vertical mullions 4"
  - Thickness: 1-3/4"
  - Width: 1'-6" – 4'-0"
  - Height: up to 8'-0"
- 20-minute positive pressure fire-rated doors:
  - Maximum size 4'-0" x 8'-0" single or 8'-0" x 8'-0" paired.
  - Standard hinges, mortise or cylindrical locks and flush bolts.
- 5 year limited warranty.

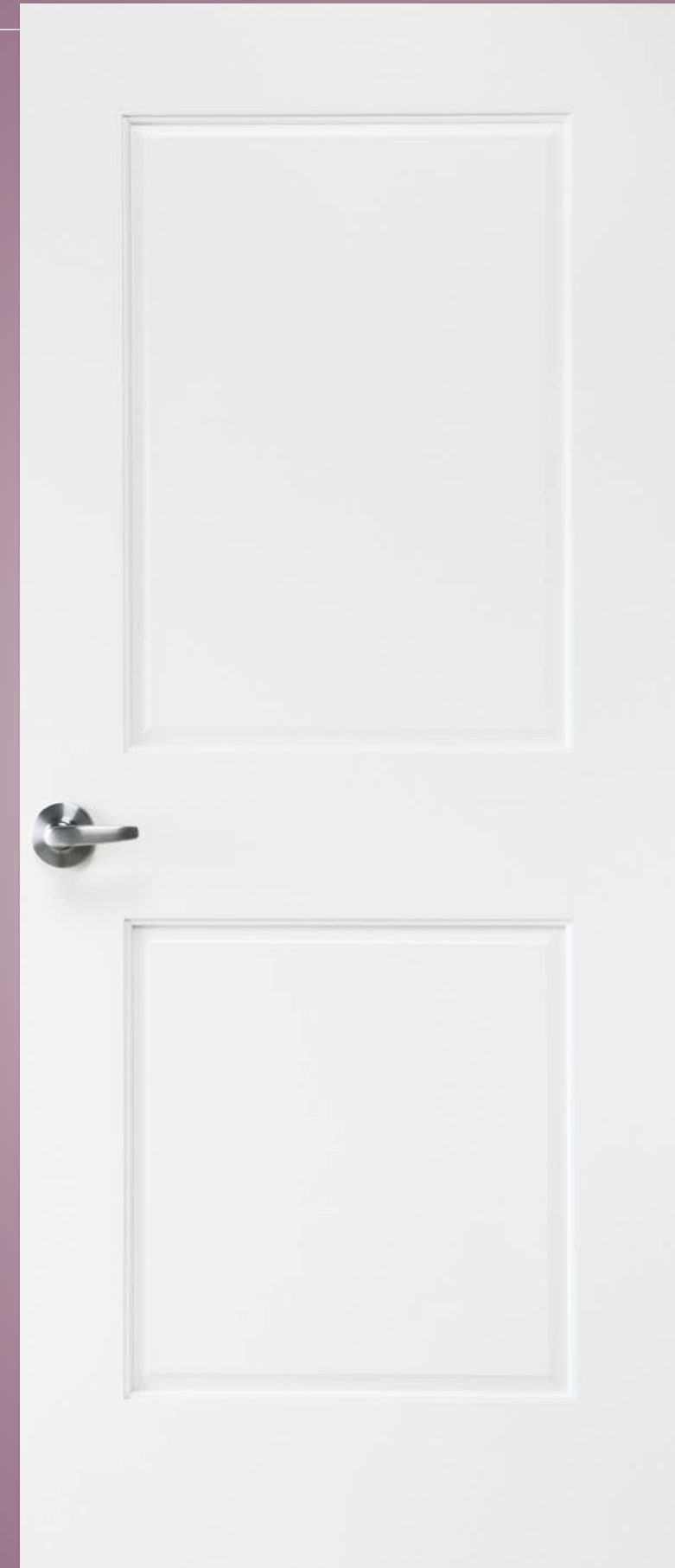

### HOW TO SPECIFY:

*Profiled doors to have HDF face and hardwood outer stiles.*

FS1021, Primed



## PERMAGUARD™ FACTORY FINISH SYSTEM.

# FINISH

### GOOD FOR THE ENVIRONMENT. GREAT FOR LONG-LASTING AESTHETICS.

Custom doors deserve a custom finish, and VT's Permaguard™ factory finish is the industry's best. Our WDMA TR-6 finish system allows you to use the classic elegance of wood throughout your project with total confidence. VT doors are finished in a dust-free environment. By using water-based stains and solvent-free sealers and topcoats on our flush wood doors, we eliminate volatile organic compounds (VOC) emissions. And our UV curing system adds a durable, protective shield to all our wood veneer doors.

### THE VT ADVANTAGE

- For high profile projects, custom color matching available.
- Simply send us a 3" x 5" physical sample of the finish color desired, and we will custom match it to meet your project needs.
- Three sealer coats and two topcoats shield and protect flush doors.
- Computer-controlled automatic sprayer provides durable, even coats on our stile & rail doors.
- Advanced computer automation flawlessly applies each coat.
- A wide variety of VT Color Choices available for quick turnaround.



Plain Sliced Cherry, Clear Finish

## VT COLOR CHOICES.

# COLOR

Streamline the color matching process for your project by selecting from VT's popular Color Choices. To ensure satisfaction, order a free sample to review before making your final decision. You'll save time and the result will be a consistent, beautiful finish with a much harder surface than can be achieved in the field because the polyurethane topcoat is baked on.

- Select from an array of popular stain colors.
- Color Choices are available in a variety of wood species, including cherry and mahogany.
- Color Choices receive the same quality and care as custom color finishes.
- Color Choices provide a faster turnaround and a more economical price.
- Refer to our Permaguard™ factory finish brochure for a complete listing of colors and species.

#### HOW TO SPECIFY:

*WDMA System TR-6 catalyzed polyurethane. The polyurethane shall be UV-cured to produce a finish per WDMA I.S. 1-A. WDMA finish types 2 and 3 are not acceptable. Top and bottom rails shall be factory-sealed with an approved wood sealer. Specify the finish. WDMA OP-6 factory painting is optional.*

### OPAQUE FINISH

- WDMA OP-6.
- Every color is customized per project.
- Simply send us a 3" x 5" physical sample of the finish color desired, and we will custom match it to meet your project needs.
- Advanced computer automation flawlessly applies each coat.
- Recommended finish material is HDF (MDO).
- Available on flush doors.
- Finish is primed and painted with a clear topcoat.





## AFFORDABLE OPTIONS FROM VT.

# OPTIONS

With options such as factory-installed glazing, applied mouldings, factory-installed louvers and wood door jambs available from VT Industries, you can achieve the look you want with the convenience you expect. VT eliminates the hassle of coordinating and handling lite kits and louvers on site, so your doors arrive ready-to-hang, regardless of the options you choose. Our standard offerings are located online at [www.vtindustries.com/doors/Accessories.shtml](http://www.vtindustries.com/doors/Accessories.shtml). Or if you have something special in mind, we'll work with you to meet your needs.

### FACTORY-INSTALLED GLAZING

- Choose from several profiles of wood mouldings to match your door face veneer.
- Specify glass type and thickness, from tempered glass to privacy lite kits.
- Primed, painted or wood-wrapped metal vision panels available in standard or custom sizes and shapes.

### SURFACE-APPLIED MOULDINGS

- Wood species available to match face veneers.
- Mouldings stained to match factory-finished doors.
- Select from an array of standard moulding profiles online at [www.vtindustries.com/doors/SurfaceAppliedMouldings.shtml](http://www.vtindustries.com/doors/SurfaceAppliedMouldings.shtml) or specify a custom design.

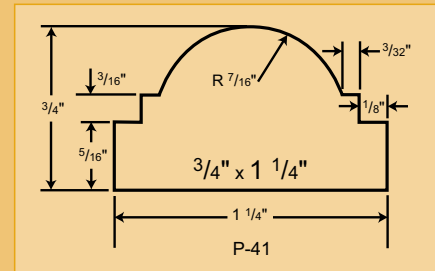

Applied Moulding Profile

### FACTORY-INSTALLED LOUVERS

- Specify louver type and size.
- Metal louvers available primed or painted, and can be installed using woodstops or metal frames.
- Wood louvers available for non-rated doors.
- Fusible link louvers meet 45-, 60- and 90-minute fire ratings.

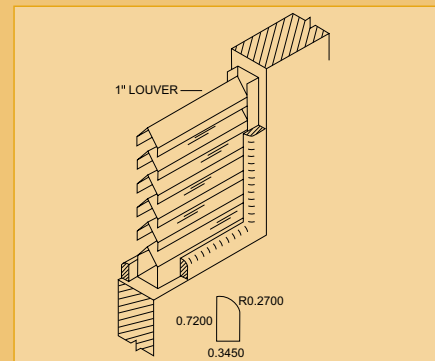

Metal Louver Profile



Plain Sliced Mahogany, Clear Finish



### WOOD DOOR JAMBS

VT provides wood door jambs to help you create perfectly coordinated openings.

- Choose from a variety of wood veneers to match VT door faces.
- 20-minute positive pressure fire rating available, maximum 4'-0" x 9'-0" opening size.
- Solid wood stop.
- SCL substrate provides dimensional stability.
- 10-foot maximum length for non-rated use.
- Jobsite assembly.
- Minimum width: 4"
- Maximum width: 9-3/4"

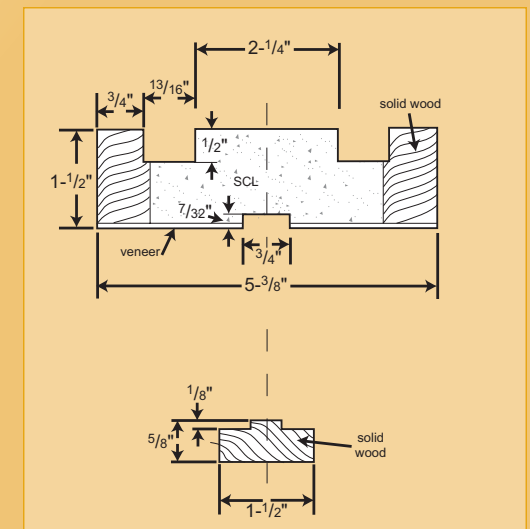

Door Jamb Detail



# AESTHETIC APPEAL FROM A POSITIVE PRESSURE DOOR? ONLY AT VT.

# APPEAL

VT Industries has responded to positive pressure fire door requirements (UBC 7-2-1997) with construction that addresses industry standards while maintaining the visual integrity of the total opening.

VT provides Category A fire doors as classified by Intertek/Warnock Hersey to meet the aesthetic needs of your overall building design. Unlike exposed edge-sealing systems that detract from the visual appearance of the door or its frame, VT's concealed intumescent provides you with the same seamless elegance as our non-rated doors.

- Maximum sizes for Neutral Pressure Doors: Singles up to 4'-0" x 10'-0". Pairs up to 8'-0" x 10'-0".
- Maximum sizes for Positive Pressure Doors: Singles up to 4'-0" x 9'-0". Pairs up to 8'-0" x 9'-0".
- Positive pressure doors meet Intertek/Warnock Hersey Category A guidelines: "No additional edge-sealing system is required."\*



Quarter Sliced Figured Sapele, Clear Finish

\* Where smoke and draft control is required by local codes ("S" rating), an approved smoke gasketing must be applied around the frame perimeter.

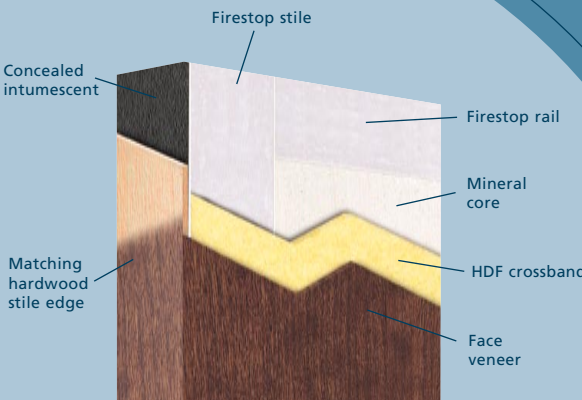

Positive Pressure

## PROVEN RELIABILITY AND QUALITY CONSTRUCTION TO MEET LIFE SAFETY REQUIREMENTS.

At VT Industries, our commitment to ongoing testing and evaluation offers a wide variety of options to meet building code requirements, including security class ratings, x-ray radiation protection and positive pressure fire door requirements.

- Non-rated and 20-minute doors carry a security class rating of 40, the highest rating possible.
- Fire-rated doors are available with ratings up to 90-minute, including new positive pressure fire doors and double egress pairs.
- Specify VT doors with laminated end rails to help eliminate the growth of harmful molds and bacteria in health care facilities and other appropriate applications.
- Lead-lined doors provide x-ray radiation protection.

### HOW TO SPECIFY:

Where UBC 7-2-1997 requirements for positive pressure must be met, doors shall include all requirements as part of door construction per Category A guidelines as published by Intertek/Warnock Hersey. No intumescent is allowed on the frame. Only smoke gasketing applied around the perimeter of the frame to meet the "S" rating is permissible.



## ACTIVE AND PASSIVE FIRE PROTECTION FOR BALANCED SAFETY

- Two major approaches to fire protection that are required by code are typically defined as "active" and "passive".
- The active approach consists of fire and smoke alarm systems, sprinklers, emergency lighting, evacuation plans/drills and automatic alerts through 911.
- The passive approach involves containment of fire and smoke. The containment is achieved through the use of fire-rated and smoke- and draft-controlled door, window and wall assemblies.
- When installed properly and not held open illegally with the use of wedges or shims, positive pressure fire doors are the most reliable approach for fire and smoke protection.
- Proper instructions for installing positive pressure fire doors are available from door, door frame and hardware manufacturers.

Passive	Balanced	Active
Containment (Control Fumes Prevent Spread)	Automatic Detection	Suppression (Automatic Extinguishing)
Insufficient Structural Protection	Slowing Fire Growth	Insufficient Life Safety Effectiveness
	Automatic Suppression	
	Fire Containment	
	Occupant Evacuation	
	(Optimal Balance)	



AT VT INDUSTRIES, EXCELLENCE IN CONSTRUCTION IS OUR STANDARD.

# EXCELLENCE

As an accommodation to your flush wood door order, VT offers a full line of specialty construction to meet your specifications. Single-source manufacturing increases uniformity throughout your entire project, while streamlining order process and delivery. Lead-lined doors from VT Industries constructed with lead thickness up to 1/2" provide protection where radiation exposure exists, and are available with 20-minute fire ratings.

## HOT PRESS TECHNOLOGY

- Meets WDMA I.S. 1-A premium grade quality standards.
- Stiles and rails bonded to core with Type I glue for a uniform bond between all components.
- Individually double-pressed for maximum strength and durability.
- Unit sanded as monolithic core assembly.
- Flush wood veneer doors feature 5-ply construction.
- High pressure decorative laminate doors available as 5-ply.
- Stile & rail doors from the same manufacturer provide consistency throughout your project.

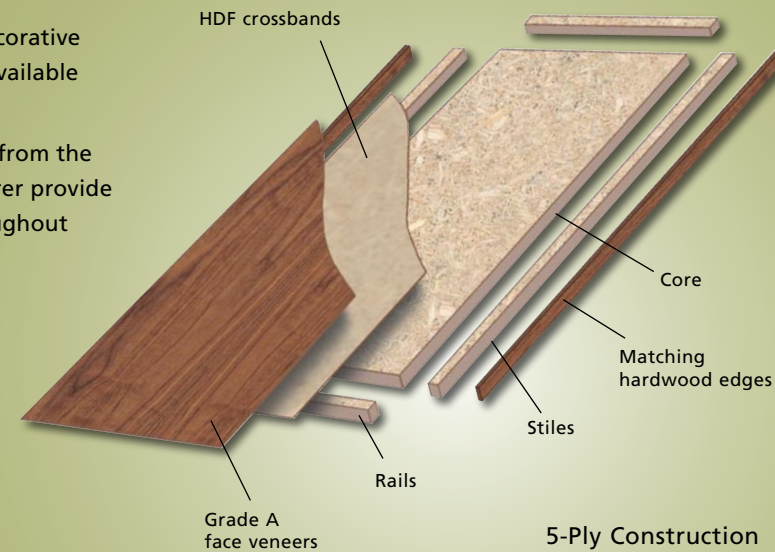

## CORE MATERIALS

- Particleboard core (1-LD-2, 28-32 lbs.).
- Structural Composite Lumber (SCL) core.
- Agrifiber core.
- Staved lumber core.
- Mineral core.
- STC-45.
- Leadlined core (1/4" maximum).

## ACOUSTICAL DOORS

- Up to STC-45 acoustical rating.
- Drop seal hardware installed at the factory for easy installation.
- VT-supplied gasketing completes STC installation.
- Utilizes standard 1-15/16" rabbeted door frames.

## ADD VALUE

Add value to every installation at no additional charge with VT Architectural Wood Doors.

- Factory machining of pre-drilled pilot holes for hinges and faceplates assures quick, correct installation.
- All doors individually poly-bagged to arrive in perfect condition.
- Factory-sealed top and bottom rails reduce installation, time and expense.
- On-time, reliable delivery on dedicated VT trucks by dedicated VT drivers.

## OUR COMMITMENT TO LEAN MANUFACTURING

Adding value to every installation with no waste drives costs down. It's a simple tenet of business. VT Industries wastes as little as possible to keep overhead low and ensures we deliver you superior products at competitive pricing.

To keep waste at a minimum, we employ every possible means of lean manufacturing – from reusing scraps of core materials to heating our plants with sawdust inevitably left over from the manufacturing process.

All employees – from manufacturing to accounting – are encouraged and involved in helping find innovative ways to make our business efficient and effective. We continually research and implement ways to make our products more efficient, providing our customers with the best possible results at the lowest price possible.

### HOW TO SPECIFY:

The door manufacturer shall drill 5/32" pilot holes for all hinges and face plates.



VT factory seals top and bottom rails.



Pre-drilled pilot holes provide ease of installation.



Doors are individually poly-bagged for added protection.





DOOR CONSTRUCTION <sup>1,2</sup>	Non-Crossbanded Particleboard Core	Crossbanded Particleboard Core	Crossbanded Stave Lumber Core	Crossbanded Structural Composite Lumber Core
THICKNESS	1-3/4", 1-3/8"	1-3/4", 2", 2-1/4"	1-3/4"	1-3/4"
CORE <sup>3</sup>	Particleboard complying with ANSI A208.1, Grade 1-LD-2	Particleboard complying with ANSI A208.1, Grade 1-LD-2	Kiln-dried wood blocks, edges glued	Structural Composite Lumber (SCL)
AVAILABLE RATINGS	Security Rating, Class 40 <sup>5</sup>	Security Rating, Class 40 <sup>5</sup>	Security Rating, Class 40 <sup>5</sup>	Security Rating, Class 40 <sup>5</sup>
NEUTRAL PRESSURE FIRE RATINGS	20-Minute Fire Door <sup>6,16</sup>	20-Minute Fire Door <sup>6</sup>	20-Minute Fire Door <sup>6</sup>	20-Minute Fire Door <sup>6</sup> 45-Minute Fire Door <sup>10†</sup>
RAILS <sup>4</sup>	1-3/8" SCL, top and bottom	1-3/8" SCL, top and bottom	1-3/8" SCL, top and bottom	1-3/8" SCL, top and bottom
STILES	1-3/8" SCL	1-3/8" SCL	1-3/8" SCL	1-3/8" SCL
POSITIVE PRESSURE FIRE RATINGS	20-Minute Fire Door <sup>6,16</sup>	20-Minute Fire Door <sup>6</sup>	20-Minute Fire Door <sup>6</sup>	20-Minute Fire Door <sup>6</sup> 45-Minute Fire Door <sup>10</sup>
RAILS <sup>4,10</sup>	1-3/8" SCL, top and bottom	1-3/8" SCL, top and bottom	1-3/8" SCL, top and bottom	1-3/8" SCL, top and bottom
STILES <sup>10</sup>	1-3/8" SCL	1-3/8" SCL	1-3/8" SCL	1-3/8" SCL
5-PLY WOOD VENEER MODELS	N/A	5502 [PC-5] <sup>7,13,14,15</sup> 5P02 [PC-5] <sup>7,10,14</sup>	5507 [SLC-5] <sup>7,13,14,15</sup> 5P07 [SLC-5] <sup>7,10,14</sup>	5508 [SCLC-5] <sup>7,13,14,15</sup> 5P08 [SCLC-5] <sup>7,10,14</sup>
FACES	N/A	WDMA premium grade wood veneer, cut & species of choice, or MDO	WDMA premium grade wood veneer, cut & species of choice, or MDO	WDMA premium grade wood veneer, cut & species of choice, or MDO
CROSSBANDS	N/A	High Density Fiber (HDF)	High Density Fiber (HDF)	High Density Fiber (HDF)
STILE TREATMENT	N/A	Stiles have matching hardwood edge - CROSSBANDS CONCEALED AT EDGE	Stiles have matching hardwood edge - CROSSBANDS CONCEALED AT EDGE	Stiles have matching hardwood edge - CROSSBANDS CONCEALED AT EDGE
HIGH PRESSURE DECORATIVE LAMINATE MODELS	303 [PC-HPDL-3] <sup>7,8,13,14,15</sup> 3P03 [PC-HPDL-3] <sup>7,10,14</sup>	404 [PC-HPDL-5] <sup>7,13,14,15</sup> 4P04 [PC-HPDL-5] <sup>7,10,14</sup>	707 [SLC-HPDL-5] <sup>7,13,14,15</sup> 7P07 [SLC-HPDL-5] <sup>7,10,14</sup>	808 [SCL-HPDL-5] <sup>7,13,14,15</sup> 8P08 [SCL-HPDL-5] <sup>7,10,14</sup>
FACES	.050" (1.3 mm) general purpose HPDL	.050" (1.3 mm) general purpose HPDL	.050" (1.3 mm) general purpose HPDL	.050" (1.3 mm) general purpose HPDL
CROSSBANDS	N/A	High Density Fiber (HDF)	High Density Fiber (HDF)	High Density Fiber (HDF)
STILE TREATMENT <sup>9</sup>	Laminate edges applied prior to faces	Laminate edges applied prior to faces - CROSSBANDS CONCEALED AT EDGE	Laminate edges applied prior to faces - CROSSBANDS CONCEALED AT EDGE	Laminate edges applied prior to faces - CROSSBANDS CONCEALED AT EDGE
LITE CUTOUTS Frames furnished	All sizes available for non-rated doors. Max. 1296 sq. in. (36" w or 54" h) for 20-min. <sup>12,13,14</sup>	All sizes available for non-rated doors. Max. 1296 sq. in. (36" w or 54" h) for 20-min. <sup>12,13,14</sup>	All sizes available for non-rated doors. Max. 1296 sq. in. (36" w or 54" h) for 20-min. <sup>12,13,14</sup>	All sizes available for non-rated doors. Max. 1296 sq. in. (36" w or 54" h) for 20-min. <sup>12,13,14</sup> Max. 864 sq. in. (24" w or 36" h) for 45-min. <sup>13,14</sup>
LOUVER CUTOUTS <sup>6</sup> Louvers available.	All sizes available for non-rated doors.	All sizes available for non-rated doors.	All sizes available for non-rated doors.	All sizes available for non-rated doors.

<sup>1</sup>All VT doors are intended for interior use only. <sup>2</sup>All VT doors meet or exceed WDMA I.S. 1-A and AWI Section 1300 quality standards. <sup>3</sup>All VT stiles and rails are bonded to core, and unit is sanded as monolithic core assembly. <sup>4</sup>All doors are available with larger top and bottom rails and with additional hardware blocking when specified. <sup>5</sup>Highest security rating possible per UBC standard 41-1 and ASTM F-176. <sup>6</sup>No louvers are allowed in 20-minute doors (smoke doors). <sup>7</sup>WDMA Spec Symbols listed in [brackets] beside VT model numbers. <sup>8</sup>Decorative laminate available upon request in non-crossbanded particleboard core door.

Agrifiber Core	Crossbanded Mineral Core	Crossbanded LeadLined Core	Crossbanded Composite Sound Core	Profiled
1-3/4", 2", 2-1/4"	1-3/4"	1-3/4" with lead to 1/4"	1-3/4"	1-3/4"
Agrifiber complying with ANSI A208.1, Grade 1-LD-2	Incombustible Mineral Core	Particleboard complying with ANSI A208.1, Grade 1-LD-2, with continuous lead glued to each side of framed core; multi-ply construction	Composite Sound Core, multi-ply construction	Medium Density Fiber (MDF)
Security Rating, Class 40 <sup>5</sup>	N/A	Radiation Shielding	STC 39 or 45 Sound Door	N/A
20-Minute Fire Door <sup>6,10†</sup> , 45-Minute Fire Door <sup>10†</sup> , 60-Minute Fire Door <sup>10†</sup>	45-, 60-, 90-Minute Fire Door, including 90-min. Double Egress Pairs	20-Minute Fire Door <sup>6</sup>	20-Minute Fire Door <sup>6</sup>	20-Minute Fire Door <sup>6,10,13,14</sup>
1-3/8" SCL for all 20-min and 45-min single fire doors, 1-1/2" GP Firestop at 45-min pairs & 60-min singles	1" SCL on 45-min; 1-1/2" GP Firestop on 60-min & 90-min before trimming <sup>1</sup>	3-3/8" SCL, top and bottom	3-3/8" SCL, top and bottom	1-3/8" SCL, top and bottom
1-3/8" SCL for all 20-min and 45-min single fire doors, 1-1/2" GP Firestop II at 45-min pairs & 60-min singles	1" SCL on 45-min; 1-1/2" GP Firestop II on 60-min & 90-min before trimming <sup>1</sup>	1-3/8" SCL	1-3/8" SCL with hardwood edge - CROSSBANDS CONCEALED AT EDGE	1-3/8" SCL with hardwood edge
20-Minute Fire Door <sup>6,10</sup> , 45-Minute Fire Door <sup>10</sup> , 60-Minute Fire Door <sup>10</sup>	45-, 60-, 90-Minute Fire Door, including 90-min. Double Egress Pairs	20-Minute Fire Door <sup>6</sup>	20-Minute Fire Door <sup>6</sup>	20-Minute Fire Door <sup>6,10,13,14</sup>
1-3/8" SCL for all 20-min and 45-min single fire doors, 1-1/2" GP Firestop at 45-min pairs & 60-min singles	1" SCL on all 45-min & 60-min singles; 1-1/2" GP Firestop on 60-min pairs & all 90-min doors	3-3/8" SCL, top and bottom	3-3/8" SCL, top and bottom	1-3/8" SCL, top and bottom
1-3/8" SCL for all 20-min and 45-min single fire doors, 1-1/2" GP Firestop II at 45-min pairs & 60-min singles	1" SCL on all 45-min & 60-min singles; 1-1/2" GP Firestop II on 60-min pairs & all 90-min doors	1-3/8" SCL	1-3/8" SCL	1-3/8" SCL with hardwood edge
5509 [PC-5] <sup>7</sup> 5P09 [PC-5] <sup>7,10,13,14</sup>	5545 and 5511 [FD-5] <sup>7,13</sup> 5P45 and 5P11 [FD-5] <sup>7,10,14</sup>	5515 [LL] <sup>7,13,14,15</sup> 5P15 [LL] <sup>7,10,14</sup>	5540 [SR] <sup>7,11,13</sup> , 5550 [SR] <sup>7,11</sup> 5P50 [SR] <sup>7,11,14</sup>	N/A
WDMA premium grade wood veneer, cut & species of choice, or MDO	WDMA premium grade wood veneer, cut & species of choice, or MDO	WDMA premium grade wood veneer, cut & species of choice, or MDO	WDMA premium grade wood veneer, cut & species of choice, or MDO	High Density Fiber (HDF); primed or painted
High Density Fiber (HDF)	High Density Fiber (HDF)	High Density Fiber (HDF)	High Density Fiber (HDF)	N/A
Stiles have matching hardwood edge - CROSSBANDS CONCEALED AT EDGE	Stiles have matching hardwood edge - CROSSBANDS CONCEALED AT EDGE	Stiles have matching hardwood edge - CROSSBANDS CONCEALED AT EDGE	See stile information above.	N/A
909 [PC-HPDL-5] <sup>7</sup> 9P09 [PC-HPDL-5] <sup>7,10,13,14</sup>	1345 and 1111 [FD-HPDL-5] <sup>7,13</sup> 1P45 and 1P11 [FD-HPDL-5] <sup>7,10,14</sup>	1515 [LL-HPDL] <sup>7,13,14,15</sup> 1P15 [LL-HPDL] <sup>7,10,14</sup>	1240 [SR-HPDL] <sup>7,11,13</sup> , 1050 [SR-HPDL] <sup>7,11</sup> 1P50 [SR-HPDL] <sup>7,11,14</sup>	N/A
.050" (1.3 mm) general purpose HPDL	.050" (1.3 mm) general purpose HPDL	.050" (1.3 mm) general purpose HPDL	.050" (1.3 mm) general purpose HPDL	N/A
High Density Fiber (HDF)	High Density Fiber (HDF)	High Density Fiber (HDF)	High Density Fiber (HDF)	N/A
Laminate edges applied prior to faces - CROSSBANDS CONCEALED AT EDGE	Laminate edges applied prior to faces - CROSSBANDS CONCEALED AT EDGE	Laminate edges applied prior to faces - CROSSBANDS CONCEALED AT EDGE	See stile information above.	N/A
All sizes available for non-rated doors. Max. 1296 sq. in. (36" w or 54" h) for 20-min. <sup>12,13,14</sup>	Max. 1296 sq. in. (36" w or 54" h) for 45-min; Max. 100 sq. in. (10" w or 33" h) for 60-min or 90-min <sup>12,13,14</sup>	Max. 256 sq. in. (16" w or 16" h) for 20-min.	Max. 216 sq. in. with STC 39 or 44 rating. Door is furnished factory glazed.	N/A
All sizes available for non-rated doors.	Max. 576 sq. in. (24" w or 24" h)	N/A	N/A	N/A

<sup>8</sup>Decorative laminate doors are also available with unfinished, stained or painted hardwood edges. <sup>9</sup>Intumescent concealed along stile edge and surface applied along top rail. <sup>10</sup>Gasketing and drop seal included. <sup>11</sup>Larger lite sizes available using special materials. <sup>12</sup>Negative pressure fire rating available. <sup>13</sup>Positive pressure fire rating available. <sup>14</sup>20-min positive pressure restrictions: single door only; for use in hollow metal frame. <sup>15</sup>Doors thinner than 1-3/4" cannot carry a fire label (non-rated only). <sup>16</sup>With Positive Pressure Construction.



# VT STILE & RAIL DOORS

# STANDARD ELEVATIONS

## ELEVATION DESIGN OPTIONS

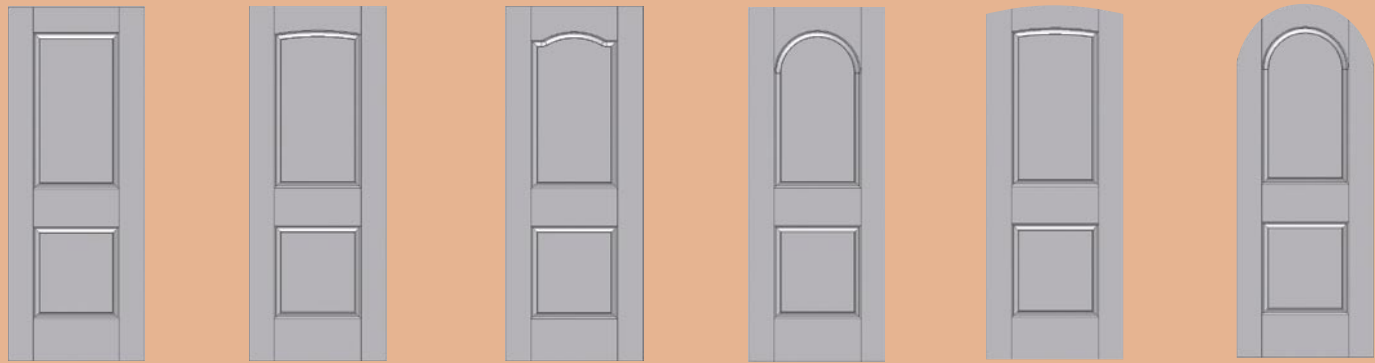

- SS** Square Door Top Square Top Panel
- SA** Square Door Top Arch Top Panel
- SC** Square Door Top Colonial Top Panel
- SR** Square Door Top Radius Top Panel
- AA** Arch Door Top Arch Top Panel
- RR** Radius Door Top Radius Top Panel

## 1000 SERIES\*



## 3000 SERIES\*



## 5000 SERIES\*

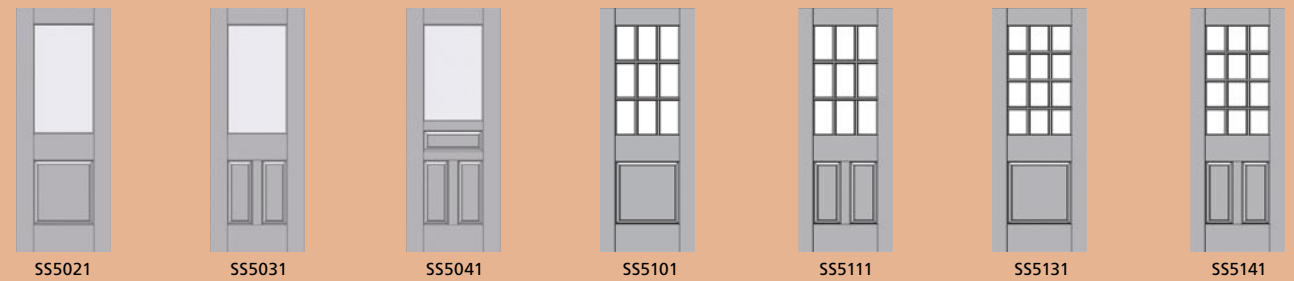

## 7000 SERIES\*



## 9000 SERIES\*

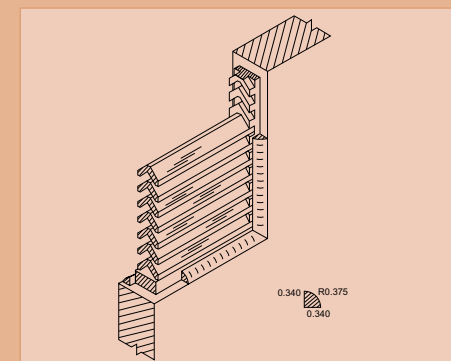

Wood Louver Profile

### STICKING USED ON FLAT PANELS

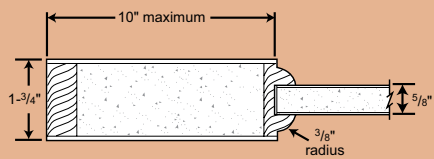

OVOLO

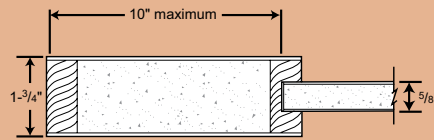

SQUARE

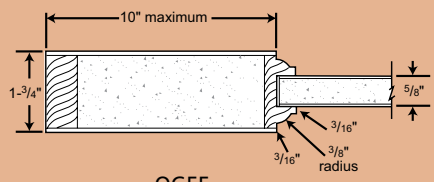

OGEE

### STICKING USED ON RAISED PANELS

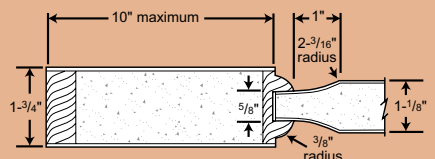

OVOLO

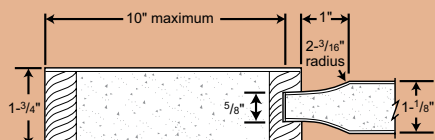

SQUARE

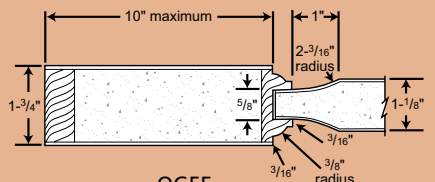

OGEE

### STICKING USED WITH GLASS

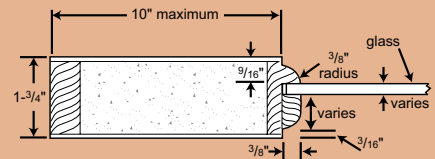

OVOLO

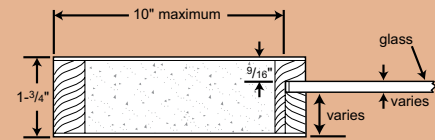

SQUARE

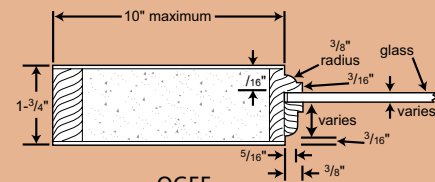

OGEE

\*Additional elevations are available. Contact customer service or visit our Web site. Custom designs available for all series within component dimension parameters.

VT STILE & RAIL DOOR COMPONENT

# DIMENSIONS

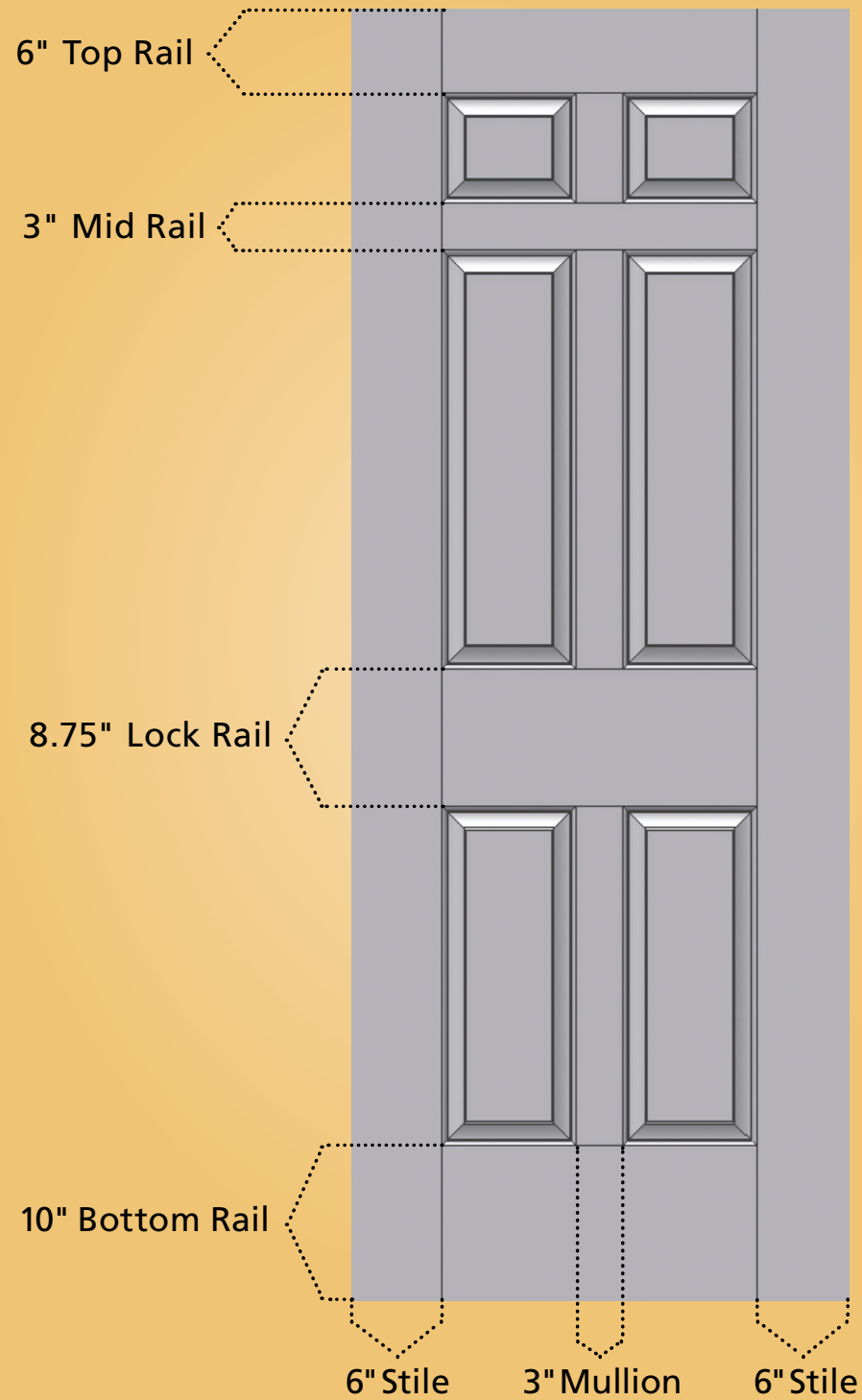

VT PROFILED DOOR

# ELEVATIONS

ELEVATION DESIGN OPTIONS



ROUTING PROFILES

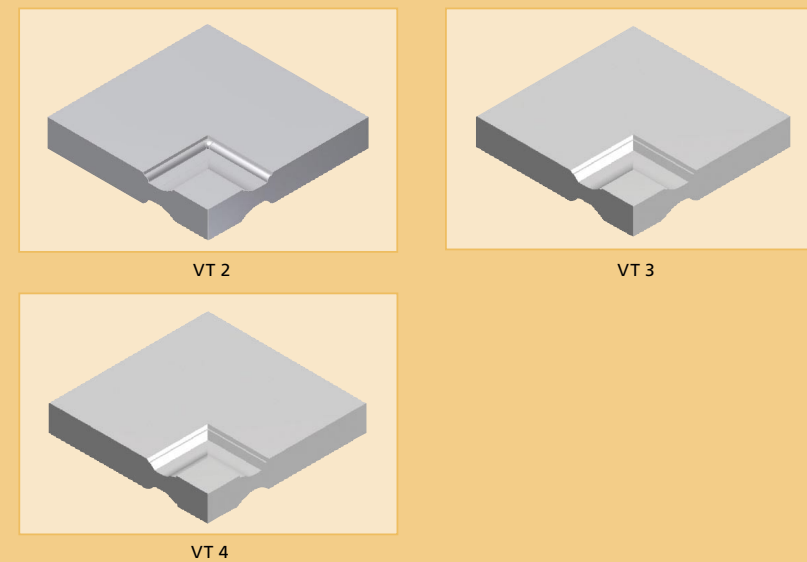

FA1021, Primed



# CONTINUING EDUCATION

VT values the importance of continuing educational efforts and conducts sessions to help architects earn AIA/CES learning units. All courses are also registered with the Doors and Hardware Institute continuing education program.

As an added benefit, we offer on-site presentations on subjects such as:

- VTI 103 – Specifying HPDL Architectural Wood Doors
- VTI 202 – Wood Door Construction\*
- VTI 303 – Veneers for Architectural Wood Doors
- VTI 405 – What is Positive Pressure & How Does It Affect Wood Door Opening Assemblies?\*
- VTI 506 - LEED Choices in Wood Door Construction\*

\* *These courses count toward Health, Safety, Welfare.*

Each course is approximately one hour long and is registered by VT with the University of Oklahoma for Continuing Education, earning AIA members one learning unit. If you are interested in taking one or all of the courses, please feel free to contact VT Industries at 800.827.1615 ext. 210, or contact your local VT Industries sales representative to set up a time.



The Architectural Openings Resource



1000 INDUSTRIAL PARK  
P.O. BOX 490  
HOLSTEIN, IA 51025  
P 800.827.1615 EXT. 250  
F 712.368.4183  
DOOR\_INFO@VTINDUSTRIES.COM  
WWW.VTINDUSTRIES.COM/DOORS

