

Solid Plastic Tufftec[®] 2.0 Locker Installation Instructions



SCRANTON PRODUCTS
Worry-Free Brands. Your Every Need.™



COMTEC
INDUSTRIES



Please read all of the installation instructions prior to installing this product. If you have any questions contact Scranton Products as soon as possible before installing this product.

Table of Contents

Thank you for purchasing our product, your business is greatly appreciated. If you have any questions, comments, or concerns with the product you received please contact the factory. Your feedback on our product and performance is welcome and needed in order for us to continue providing you with a quality product. Contact us at 800-445-5148 or fax 800-551-6993.

Section 1: Terminology

Section 2: Components

Section 3: Site Preparation

Section 4: Hardware

Section 5: Bases

Section 6: Lockers

Section 7: Fillers

Section 8: Flat Tops

Section 9: Slope Tops

Section 10: End Panels & Base Trim

Tools Needed:

- Chalk Line
- Tape Measure
- Screwdrivers (Phillips and Flat head)
- Adjustable Wrench
- Level
- Jigsaw
- Power Drill with a Drill Index, Masonry Bits, and a Countersink
- Blocking (Nailers)
- Scranton Products Provided Drawings

Please read all of the instructions prior to installing this product. If you have any questions contact Scranton Products as soon as possible before installing this product.

Section 1: Terminology

"Frame"

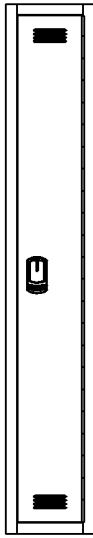

Front View

"Bank"

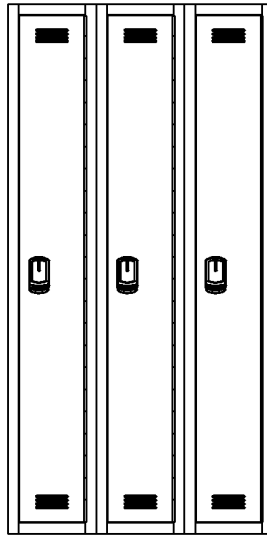

Side View

Definition of terms used:

Frame: This represents a single locker

Tier: The number of "tiers" in a frame is the number of doors in a vertical row. Shown above is a "Single Tier" locker.

Bank: A group of several (1-3) frames built as one unit. Shown above is a "Bank of three."

Profile: The profiles are the connection pieces that are used to join the panels together.

Base: Are constructed of 3/4" black material used as a foundation or a supporting member.

Filler: 1/2" trim fillers used to fill a void or cavity.

Flat top: 1/2" material provided for locker tops 60" or below.

Slope Top: 1/2" material provided for locker tops if specified.

Section 2: Components

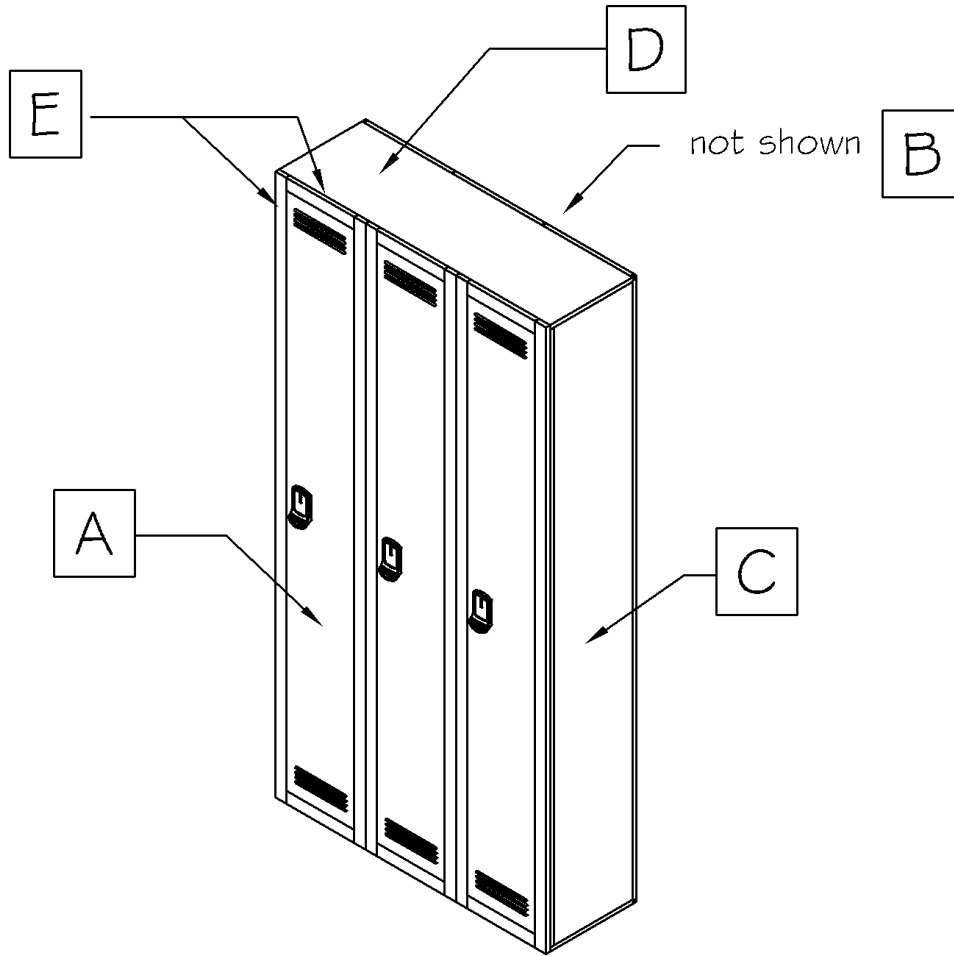

- A** Door Assembly
- B** Rear Panel (Back)
- C** Side Panel
- D** Top/Bottom Panel (With Corresponding Profiles)
- E** Face Frame (Multiple Pieces)

Section 3: Site Preparation

Storage:

Lay any loose product flat, (I.E. fillers, slope top) do not lean against a wall or stack unevenly.

Pre-Check:

Check all materials completely as soon as possible. Check items against the packing list and layouts provided. If you are missing any items or have received damaged product please contact your dealer.

Site Inspection:

Before you begin installing your Tufftec 2.0 Lockers, a complete inspection of the job site should be done. Inspect all areas in which you will be placing the lockers. Be sure to check for any variations in the wall and floor surfaces. Do pay special attention to these areas while attaching the lockers.

Note: If you have ordered the lockers with a base, you will be able to “float” the base over any low spots in the floor. Shimming may be required to ensure that the base will sit evenly and securely on the floor.

Any variations in the walls that the lockers will be attaching to should be addressed prior to beginning your installation. You may need to shim behind the lockers as to not “pull” the lockers to the wall, twisting them out of shape.

After addressing the above listed items, make sure the area is clean and free of any debris. If you are installing the lockers directly to the floor, be sure to sweep the area clean of debris before beginning.

Once the site inspection and any preparations are completed, you are ready to begin installing the lockers.

Section 4: Hardware

5/8" PAN HEAD SCREW



1" STAINLESS STEEL SCREW

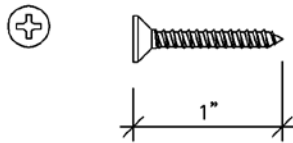

1 5/8" BLACK OXIDE STEEL SCREW

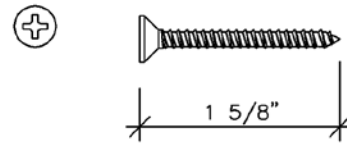

1 3/4" TAPCON SCREW

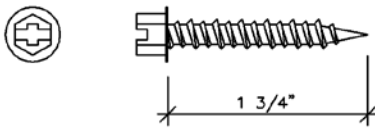

2 3/4" TAPCON SCREW

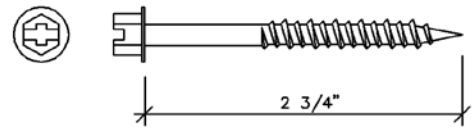

1 1/2" STAINLESS STEEL TORX HEAD SCREW (T-27)

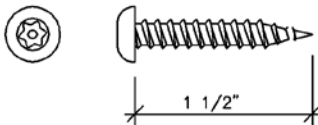

3/4" STAINLESS STEEL TORX HEAD SCREW (T-27)

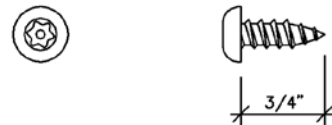

10/24 X .875" LENGTH, TORX HEAD THRU-BOLT (T-30)

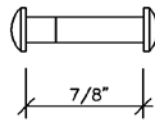
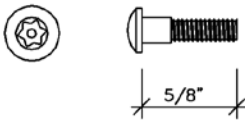

10/24 X .5938" LENGTH, TORX HEAD THRU-BOLT (T-30)

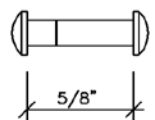
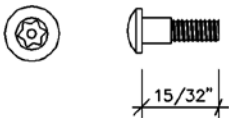

Section 5: Bases (Optional)

Locker Base Setup:

The locker bases are designed to be assembled in the field. Locate all components of the base. This will include 1" or 3/4" detailed side, front, and back portions, as well as 1" or 3/4" spreaders, corner brackets, 3/4" torx head, 1 1/2" torx head, 1 3/4" tapcon, 2 3/4" tapcon, and 1 5/8" countersink screws.

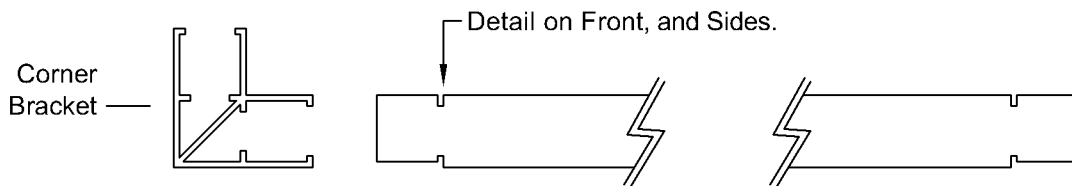

Refer to your Scranton Products Locker drawings for the correct position and layout the bases. Attach the four pieces into the corner brackets and fasten using the 3/4" torx head fasteners (T-27). **Note:** When positioned properly the outside face will set flush with the corner bracket.

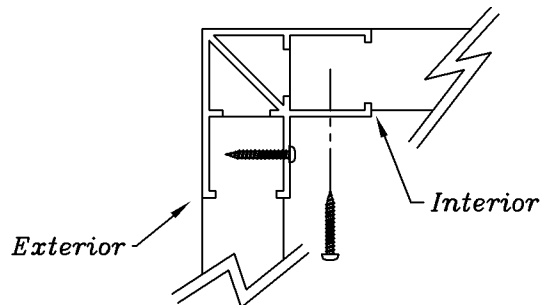

Next place your spreaders into position. The base is pre-drilled and countersunk (not drilled through). Using a 1/8" drill bit, drill through the base and into the spreader. Then fasten the base and spreader together using the 1 5/8" countersunk screws.

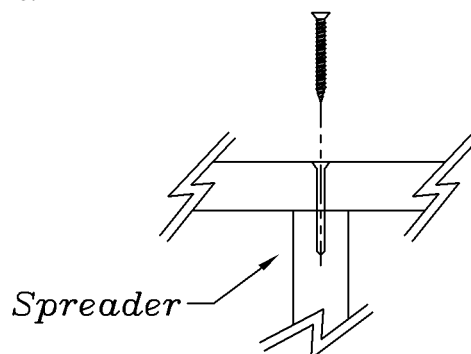

Section 5: Bases (Optional) Continued

Locker Base Installation:

Once the bases are setup make sure the area of installation is free of all debris. Locate the High and Low spots in the floor for the entire run of the lockers. Use this point as a reference to ensure that the lockers will sit level after installation. Failure to do so will result in the locker tops being uneven. Fasten the bases to the floor using the 2" aluminum angle brackets, 1 3/4" tapcon screws the base to the wall using 2 3/4" tapcon screws, and use 1 1/2" torx head fasteners (T-27) to attach base to base. Before securing the angle brackets to the floor be sure to shim as required, to make the base plumb and level. **Note:** Pre-drill wall and floor using a 3/16" masonry bit.

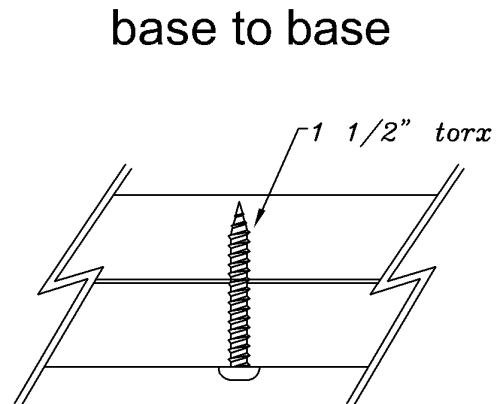
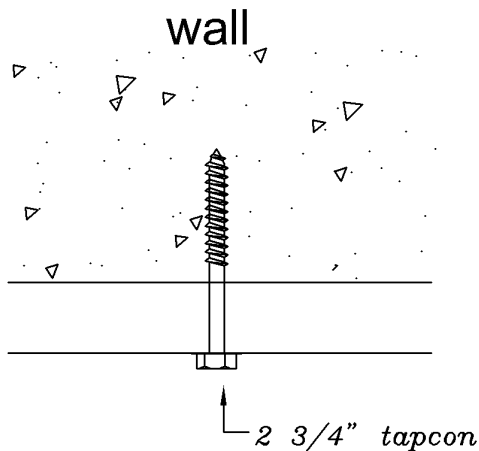
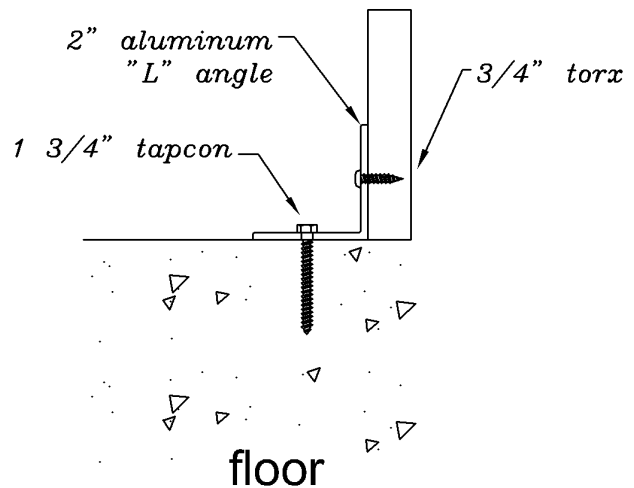
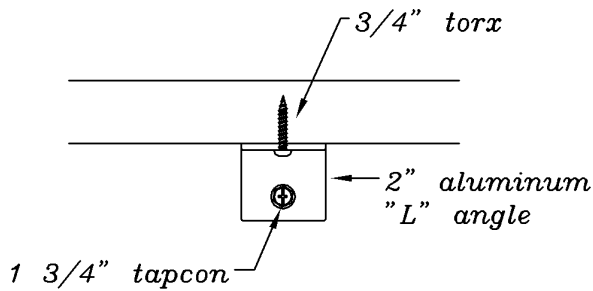

Section 6: Lockers

Setting and attaching lockers:

Once you have prepared and inspected the area, and installed the bases (if supplied), you are ready to begin setting lockers. If the lockers are being installed without a base, check the floor space and locate the high and low spots. Use this point as a reference to ensure the lockers will sit level after installation, use shimming as required. The layout drawings provided show the "bank configuration" (see below). Use this to determine the location of the different banks on the job.

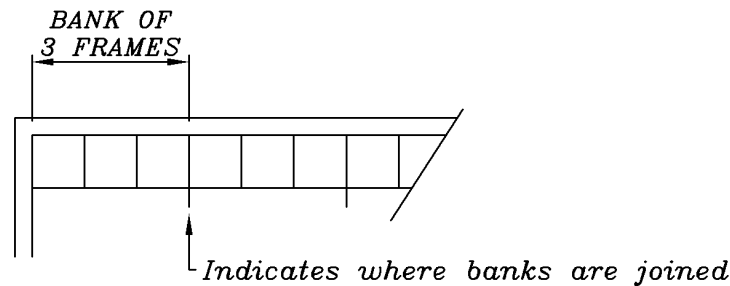

Locate the bank required for this area. Place the bank into position, and check for fit. Make sure that the bank is set square and level. This is crucial since you will be attaching the next banks to this first one.

Anchor the bank into position using the 1 3/4" tapcon screws provided. The bank will be attached to the wall at the four corners, pre-drill 1/8" hole, approximately 3" down and 3" over. DO NOT over tighten these screws at this time, just tighten enough to hold the bank into position.

Attach the locker to the base (if supplied) at the front. Secure using the 1 1/2" torx head fasteners provided.

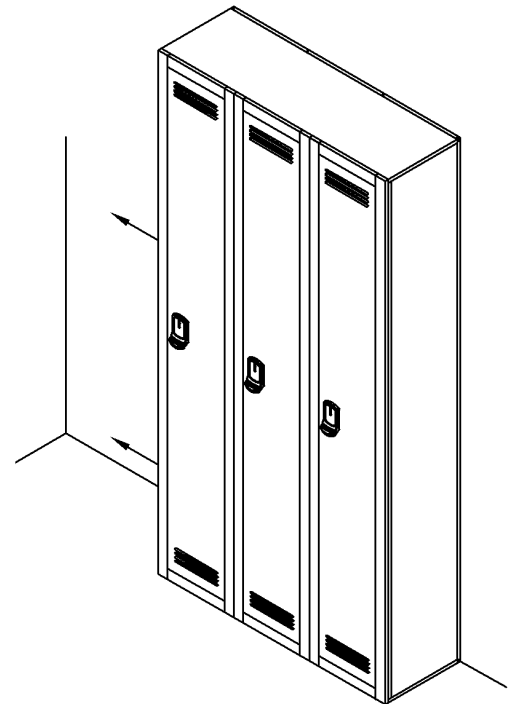

Section 6: Lockers Continued

Setting and Attaching Lockers Continued:

Locate the next bank of lockers to be installed. Place this bank into position next to the first bank installed. Locate the pre-drilled holes on the side of the face frame. You will join the second bank to the first bank using the 7/8" torx head thru-bolts (T-30) provided, join the banks together, being careful not to over tighten the screws at this time.

Locate the next banks required and continue joining them together. Once you have several banks joined together, you can go back and attach these to the walls. Attach to the wall at the first frame on the right side of each bank.

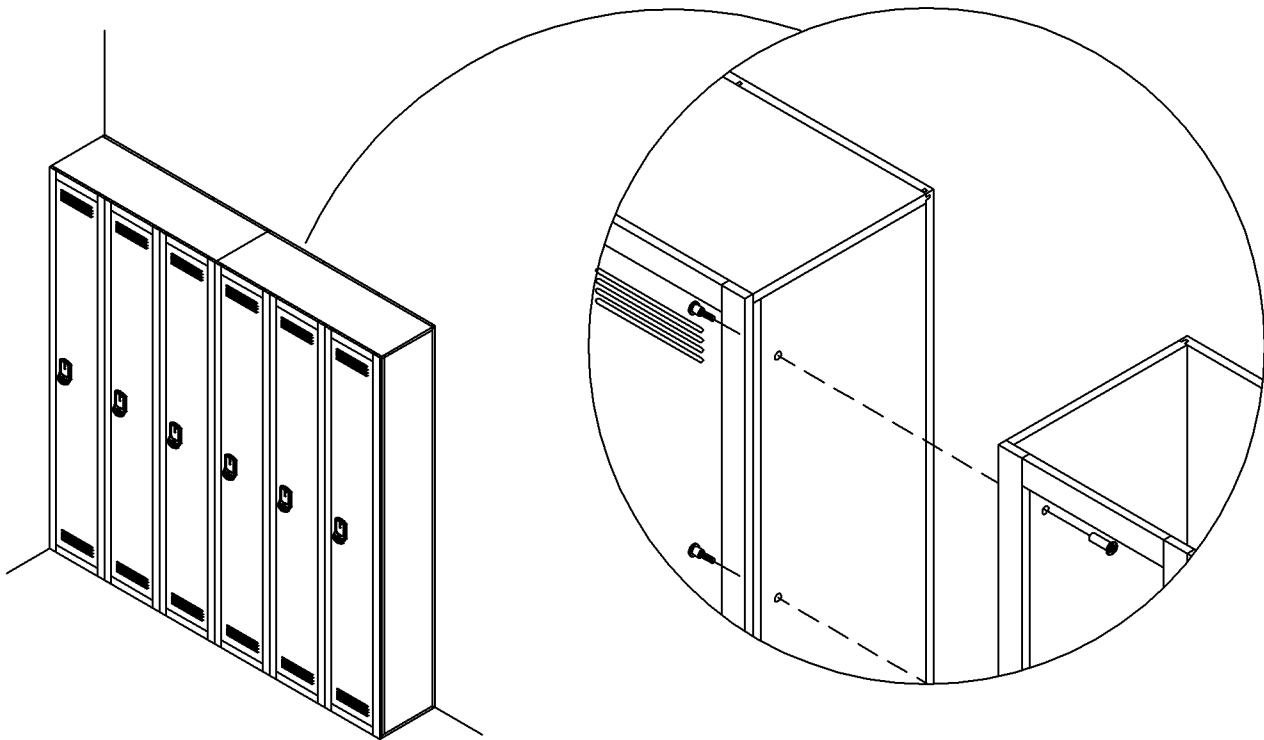

Note: If shimming is required place shims where frames meet. DO NOT shim directly under the door, this may cause improper functioning of the door.

Section 6: Lockers Continued

Setting and Attaching Lockers in an Island:

When building an island begin joining your first set of banks back to back. Pre-drill 1/4" holes approximately 3" down and 3" over in the four corners of the bank. Securely fasten using the 1/2" torx head thru-bolts (T-30) provided. Lockers should sit flush and level. This will provide a rigid starting point. Begin setting the next bank into place attaching side to side and then back to back keeping the lockers level and securely fastened. If bases are provided then secure using 1 1/2" torx head fasteners (T-27). If bases are not provided, attach using 1 3/4" tapcon screws provided.

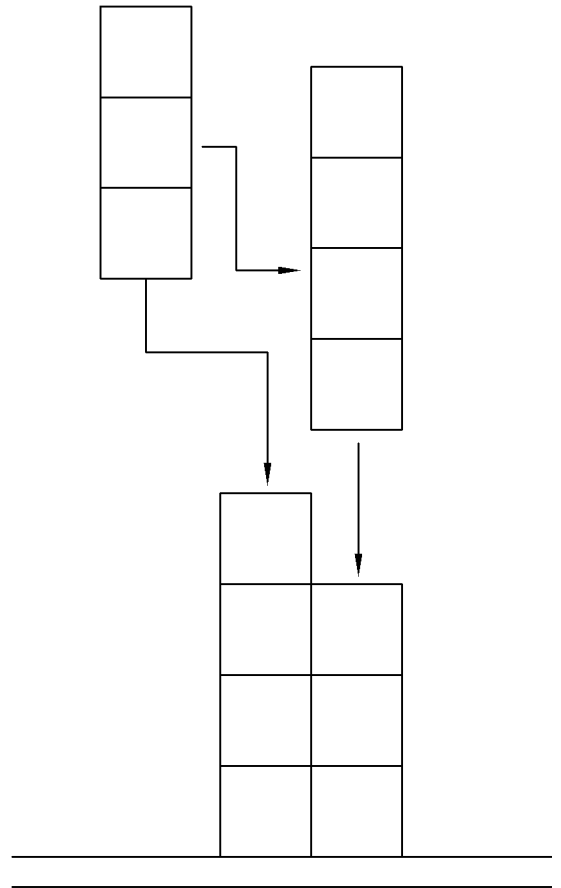
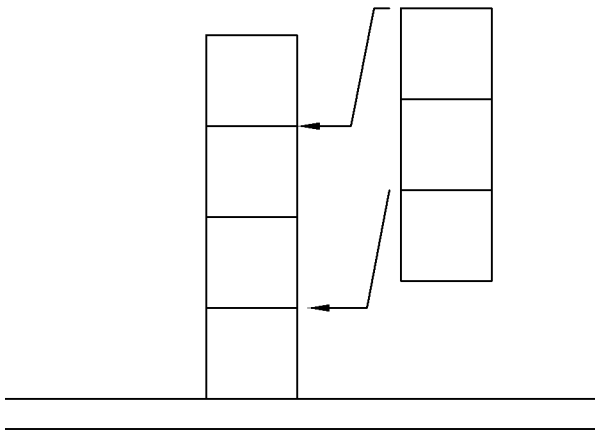
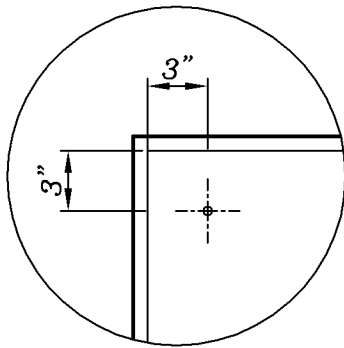

Section 7: Fillers

Filler Attachment:

Note: Blocking (wood, metal stud, etc) is required to install fillers. Blocking is NOT provided by Scranton Products.

Refer to the Scranton Products layouts for filler location and sizes, fillers may be oversized by 3" and need to be trimmed in the field due to field conditions. In the example below, blocking will need to be attached to the wall and the locker. Where attaching to walls fasteners are not provided due to varying field conditions.

Preset your fillers into place, marking locations for blocking. When installing blocking to the locker, pre-drill from the inside using a 1/8" drill bit and countersink before fastening. Using the 1" countersink fastener attach your blocking. Next, align your filler, and pre-drill and countersink your holes. Eight 1" fasteners are provided per filler, however a location at the top, middle, and bottom will be sufficient.

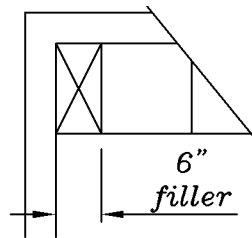

Note: fillers may be set flush with the front of the lockers or set back up to 1/8".

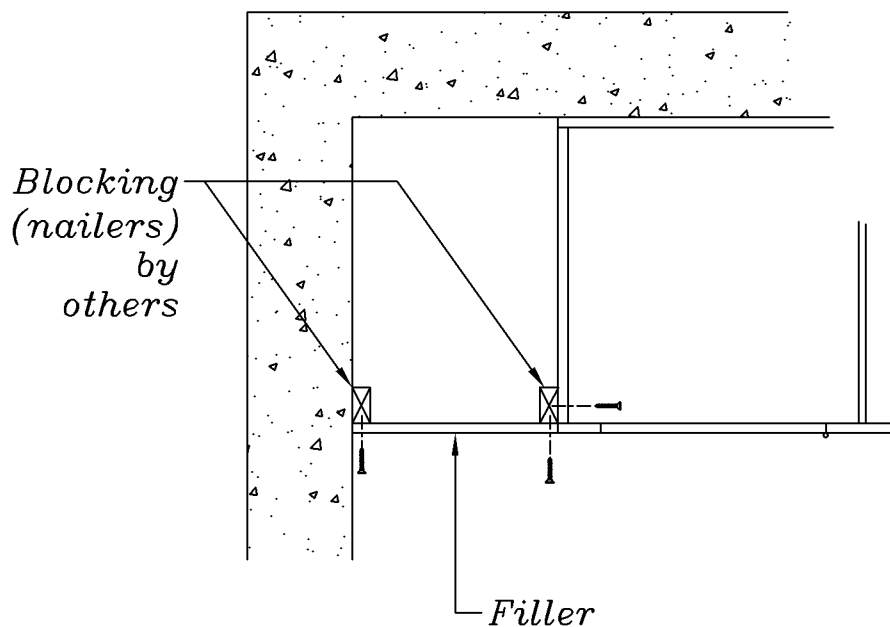

Section 7: Fillers Continued

Corner Filler Attachment: (Single)

Note: Blocking (wood, metal stud, etc.) is required to install fillers. Blocking is NOT provided by Scranton Products.

Refer to the Scranton Products layouts for filler location and sizes. The single corner fillers are provided oversized by 3". Align your filler with the lockers and mark for your blocking. Pre-drill blocking (A) using a 1/8" drill bit and countersink the holes. Fasten from the inside of the locker using the 1" countersunk fastener. Slide your filler into place and pre-drill and fasten using the same methods as stated above.

Next pre-drill (B) through the inside locker and through the filler. Countersink the holes and fasten using the 1" countersunk screws provided.

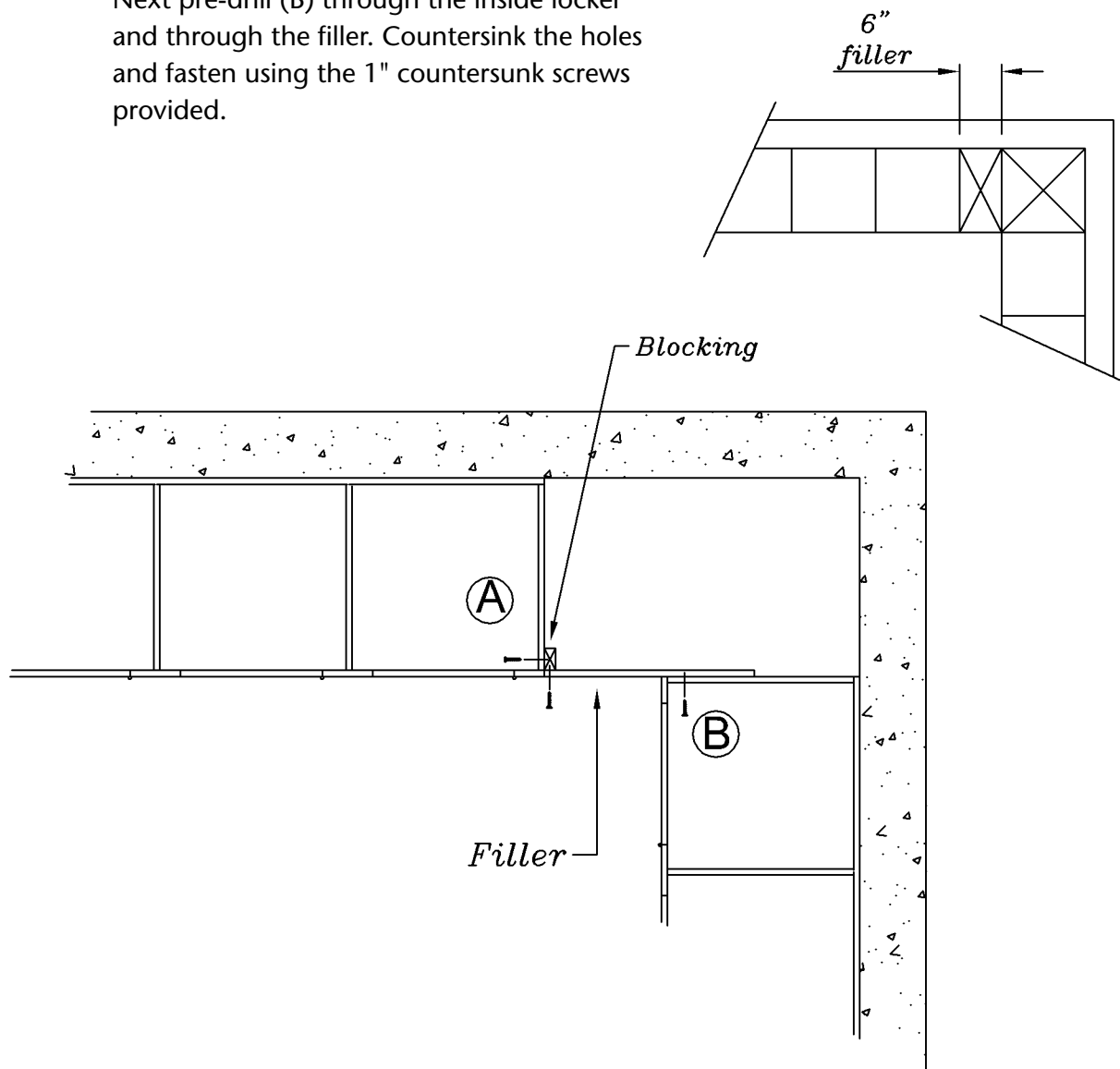

Section 7: Fillers Continued

Corner Filler Attachment: (Double)

Note: Blocking (wood, metal stud, etc.) is required to install fillers. Blocking is NOT provided by Scranton Products.

Refer to the Scranton Products layouts for filler location and sizes. Align your fillers and mark for blocking and the intersection where the two fillers meet. Pre-drill the lockers using a 1/8" drill bit and countersink the holes. Attach your blocking using the 1" countersunk screws provided. Next align the two fillers that you had previously marked and use the same method as stated above for pre-drilling and attaching. Finally set your corner filler into place and pre-drill and fasten into the blocking.

For an optional method produce a corner brace using two pieces of blocking and pre-drill and attach using the same methods as above.

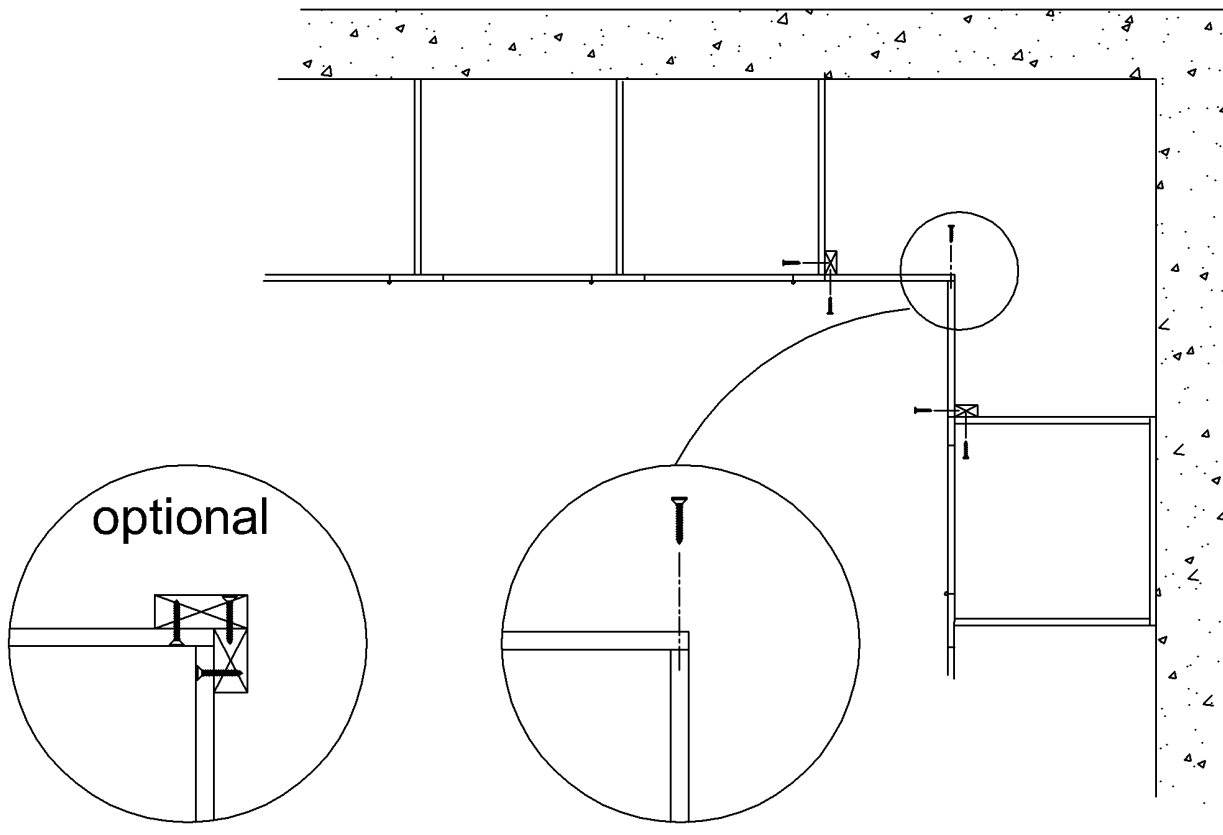
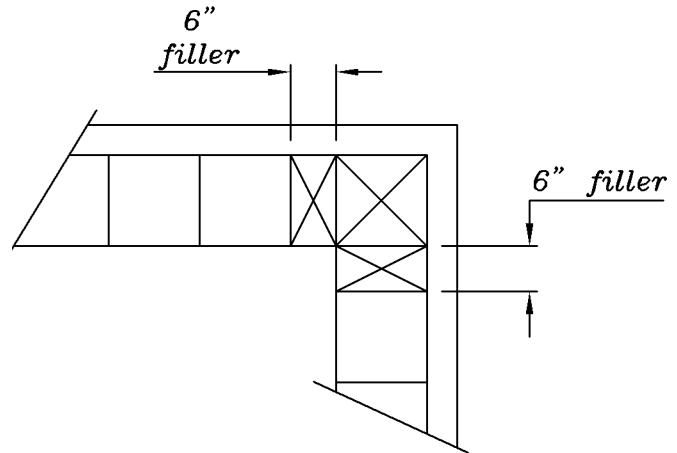

Section 8: Flat Tops

Flat Top Installation:

Flat tops are provided for a finished look on lockers that are 60" high and under. Once the lockers are installed you can attach the flat top finish panel. These are provided as 1/2" material in 72" sections with a 1/2" overhang on the front of the lockers. They are the same color as the lockers. Last panel will need to be cut to length.

First locate the flat top panels for the section you are working in. Next line up the flat top panel with the back edge of the lockers. Pre-drill the flat top panel using a 1/8" drill bit from inside the cabinet. Fasten the flat top to the lockers using the 5/8" pan head screw, fastening from inside the cabinet.

Note: Locker cabinets are 3/8" thick and flat tops are 1/2" thick. Fastening from inside the cabinet allows more grip from the fasteners and a cleaner look.

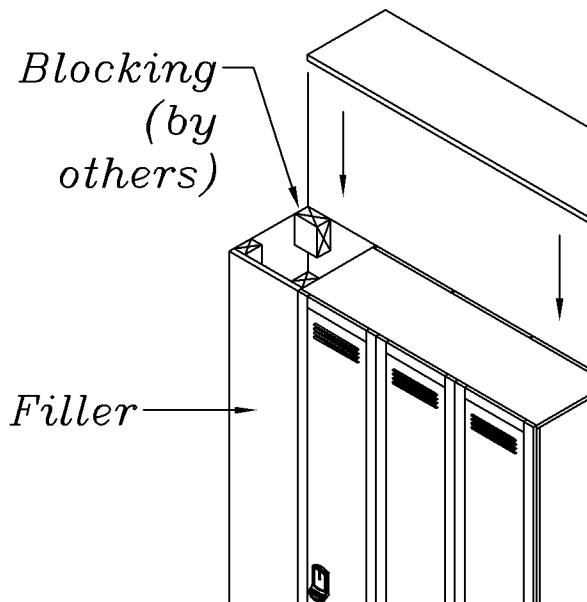
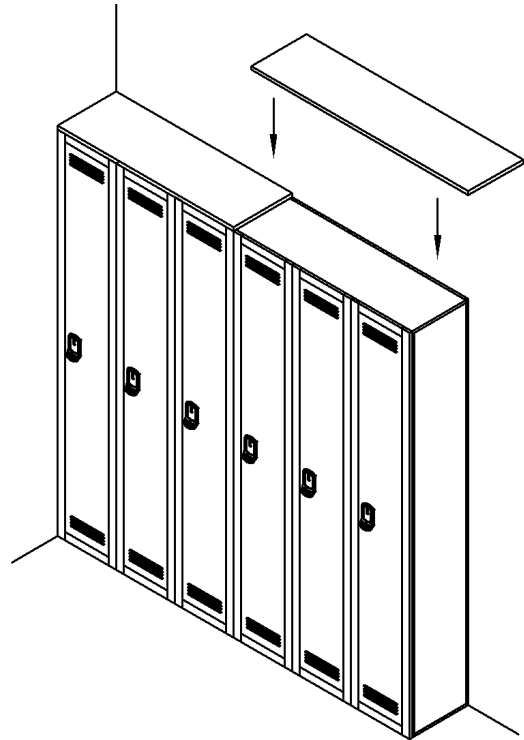

When installing flat top panels over fillers, fasten blocking where necessary to support the flat top panel. Pre-drill and fasten using the same methods as stated above.

Section 9: Slope Tops

Slope Top Installation:

First locate all components provided for the slope tops. This will include; slope top profiles, 3" strips (either 3/8" or 1/2" material), 1" thick rear supports (may be random colors), slope top, 5/8" pan head screws, 1" stainless steel screws, and corner joint profiles (not shown).

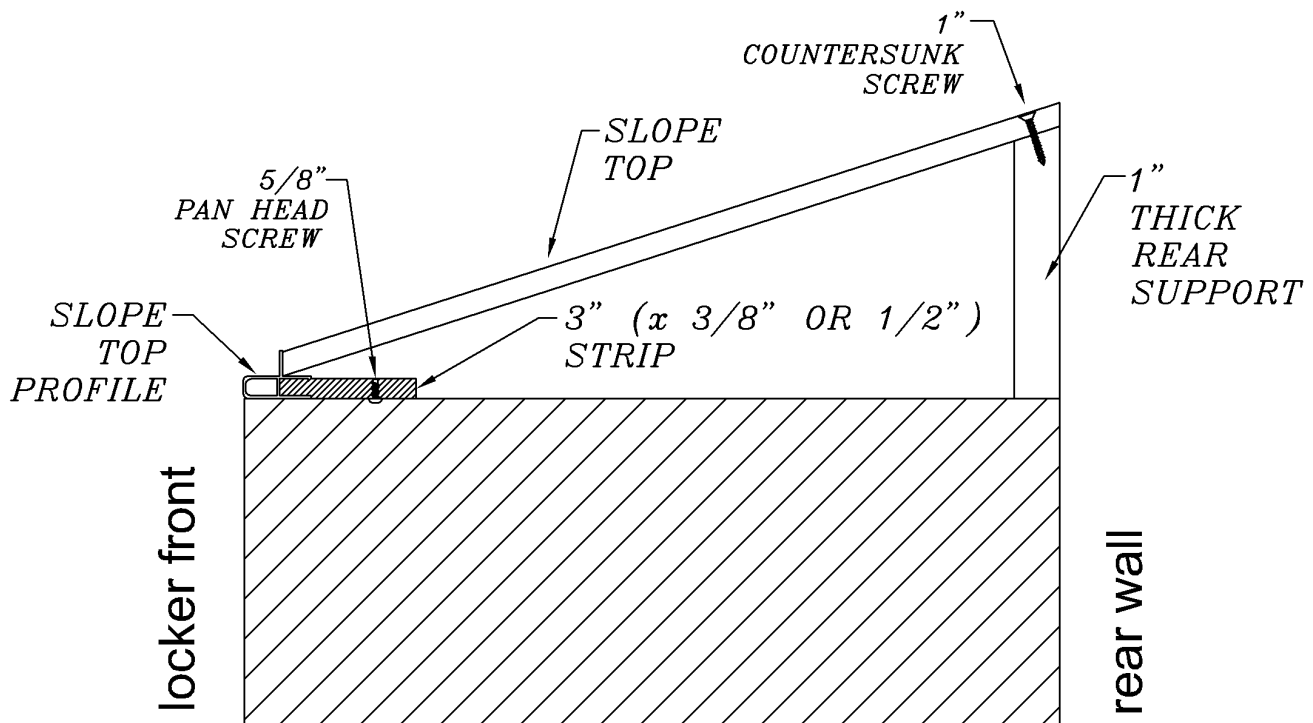

Typical side elevation of a finished slope top.

The first component to be installed for the slope tops is the 1" thick rear support. Mark the location for the rear support and snap a chalk line along the entire row. Please note that the rear supports are generally random lengths, colors, and will be concealed under the slope top so joints do not have to be perfect. Fasten the rear support to the wall using the 2 3/4" tapcon screws provided.

Note: If your layout requires an inside corner see the slope top corner section at this time. Corners require the rear support to be scribe cut for sufficient support.

Note: All slope top sizes are marked on the drawings that ship with the order.

Section 9: Slope Tops Continued

Slope Top Installation Continued:

Next take the 3" strip and the corresponding slope top profile and snap them together. This section provides the "lip" for the slope top to sit behind. Bring this segment to the front of the locker top. Pre-drill and fasten using the 5/8" pan head screws provided.

Finally take your slope top and set it into place. Pre-drill and countersink the holes at the rear section. Fasten the slope top to the 1" thick rear support using the 1" countersunk screws provided.

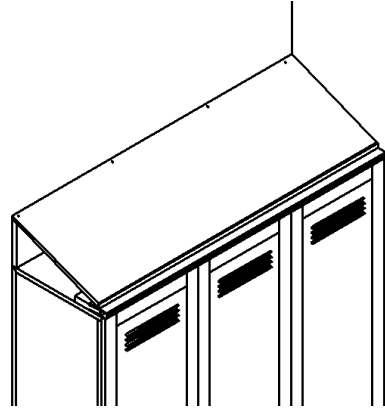

Note: Open ends will be covered by end panels. (section10.)

Slope Top Installation (Corner):

Note: Section A is a full piece of slope top to the wall, and Section B will have your compound miter corner.

When installing slope tops in a corner begin by installing the 1" thick rear support for section A. Next take the corresponding 3" strip and profile and snap them together. Fasten the strip to the locker using the 5/8" pan head screws provided. Next slide your slope top into place. Do not fasten at this time. Slide the 1" thick rear support for section B to the wall and using the slope top scribe a line into the rear support. At this time you can mark and fasten blocking under the inside corner of section A, this will prevent section A from bowing. Take your rear support and cut along your scribe line. Set your slope top piece back into place and pre-drill and fasten using the 1" countersunk screws provided.

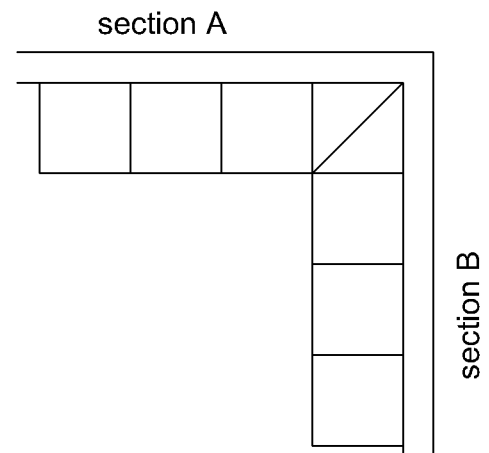

Section 9: Slope Tops Continued

Slope Top Installation (Corner) Continued:

Once section A is into place you can go ahead and install the rear support for section B. Next take the corresponding 3" strip and slope top profile and install using the same method of attachment as stated earlier. Finally take your slope top with the compound miter corner and slide into place and pre-drill and countersink the holes. Using the 1" countersunk fasteners provided, fasten into the rear support.

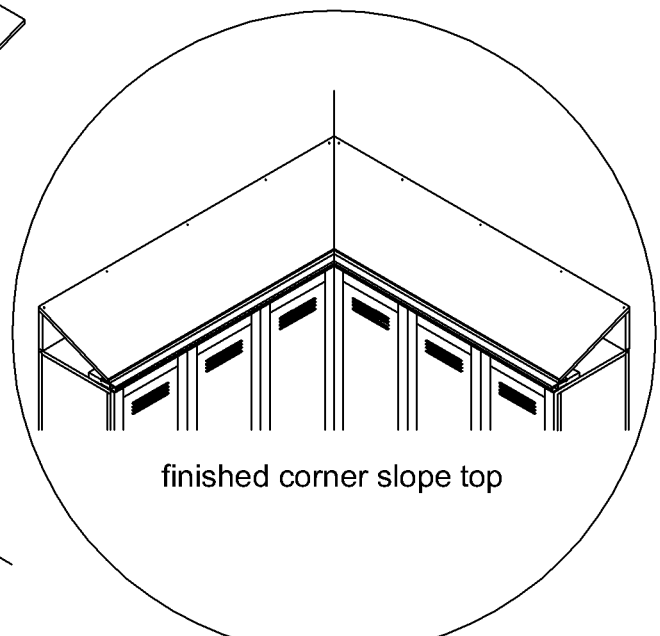
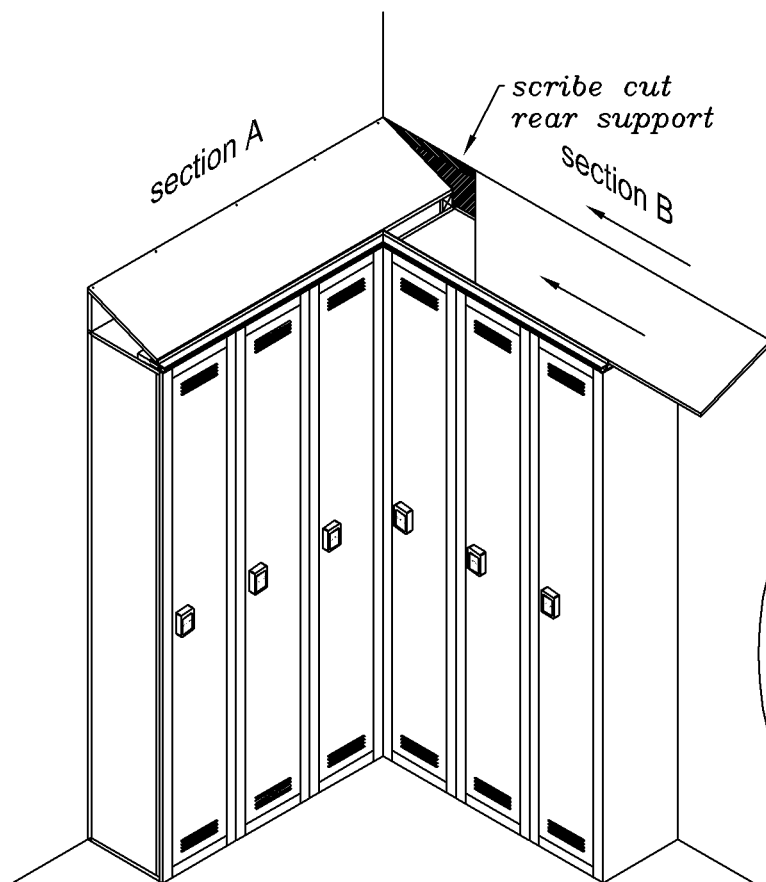
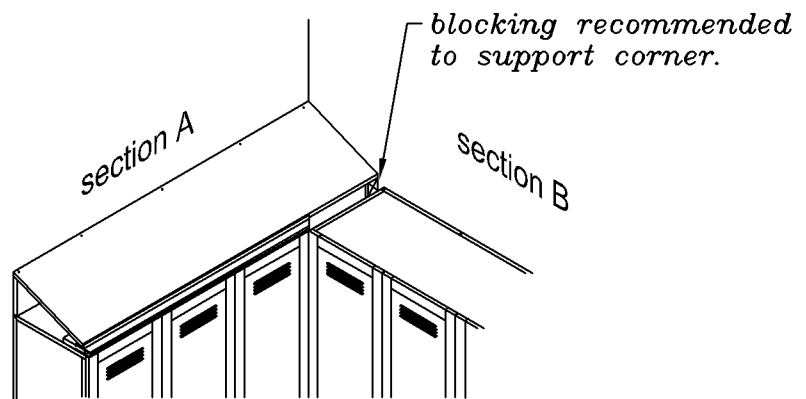

Section 9: Slope Tops Continued

Slope Top Installation (Island):

The first step when installing slope tops in an island is to fasten the rear supports together using the 1 1/2" torx head fasteners provided. Once the rear supports are fastened together begin setting them into position. Pre-drill from inside the cabinet to the under side of the combined 1" rear supports. Next fasten from the inside of the cabinet using the 1 1/2" torx head fasteners provided.

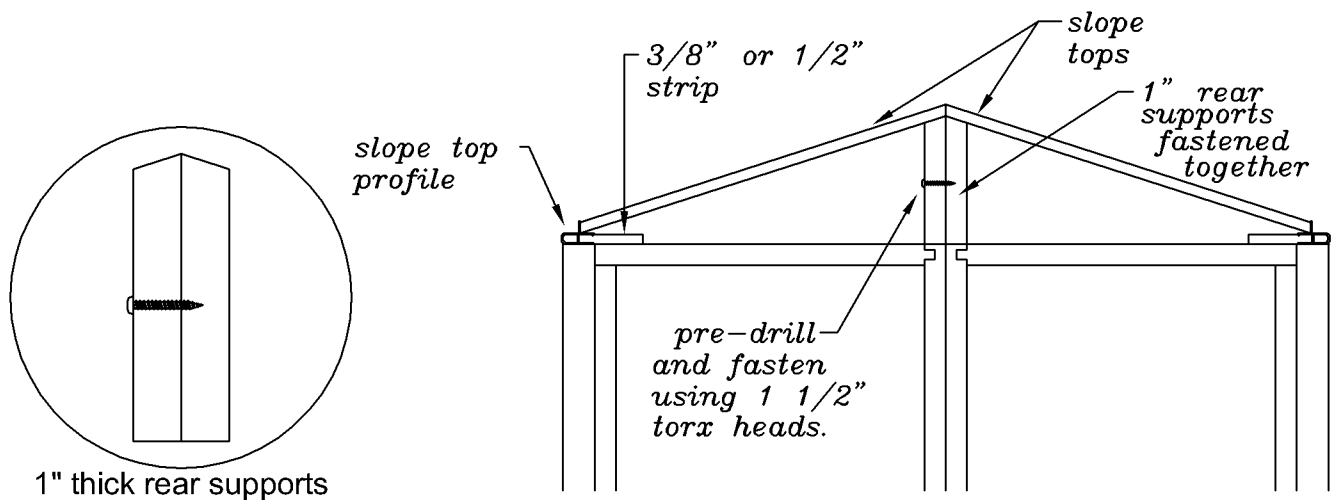

Once the 1" rear supports are installed go ahead and snap your 3" strips and slope top profiles together. Pre-drill and fasten the 3" strips with slope top profile to the locker front using the 5/8" pan head screws. Next slide your slope top pieces into place and begin pre-drilling and fastening. The slope top pieces are fastened to the rear supports using the 1" countersunk screws provided.

Section 10: End Panels & Base Trim

End Panel Installation:

End panels are provide on open ends. These panels are 1/2" thick and are designed to be attached to the end runs where the side of the lockers are exposed. Begin by aligning your end panel with locker. Next pre-drill from the inside of the lockers and into the end panel. **Note:** DO NOT pre-drill all the way through the end panel. Next fasten the end panel from the inside of the locker using the 5/8" pan head screws provided.

If your lockers are provided with Scranton Products bases and/or slope tops, the end panels will be detail to conceal these.

Base Trim Installation:

If your order was provided with base trim, you will have received 1/2" trim pieces the same color as the locker to be fastened to the base. Be sure that all the bases and lockers are installed before installing the base trim. The base trim is 4" high and runs in long sections. To attach to the bases first set up your trim piece and pre-drill hole locations using a 3/32" drill bit. Finally secure the trim piece to the base using the 1" stainless steel roll pins provided.

