

## Series D318 Durastile™ Heavy Duty Entrance\* • Series D518 Durastile™ Heavy Duty Entrance\* 2" Heavy Duty Aluminum Swing Entrance Doors



### CONFIGURATIONS

#### Medium Stile (3 1/2") • Wide Stile (5")

EFCO's Durastile entrances are designed for educational facilities, detention centers and other facilities requiring security in high abuse traffic locations. Durastile entrances are joint plug welded at every corner to provide superior strength in all applications. Also, multiple glazing options give you flexibility to meet specific design requirements, and the product's ability to accommodate most hardware applications increases its versatility. EFCO's Durastile entrances provide the complete solution for your fenestration needs.

### Features

Bracket reinforced and deep penetration welded corners

Accommodates up to 1" glazing

Accepts most major brands of locking hardware and panic devices

Accommodates all surface mounted, concealed overhead and floor closers

Tall bottom rails available

Variety of cross rails, door sweeps, and crash bars available

Anodized and painted finishes available

### Benefits

Meets or exceeds most specifications for commercial entrances

Flexibility in design requirements for glazing

Able to comply with special hardware specifications

Unrestricted closer choices

Meets ADA requirements

Increases configuration options

Multiple options to answer economic and aesthetic concerns



Series D318 Durastile™ Heavy Duty Entrance\* • Series D518 Durastile™ Heavy Duty Entrance\*  
**2" Heavy Duty Aluminum Swing Entrance Doors**

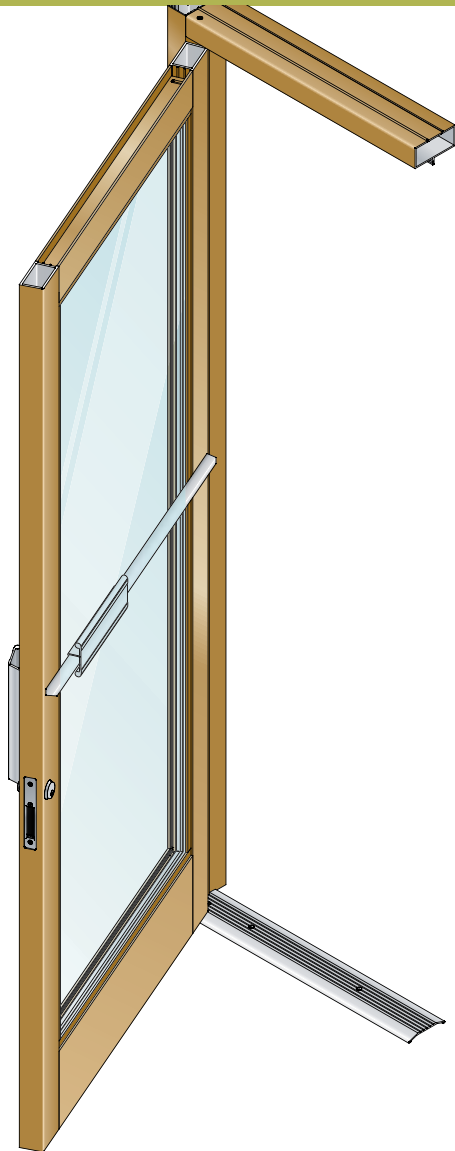

**STILES**

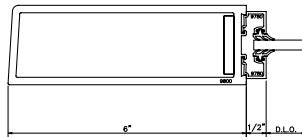
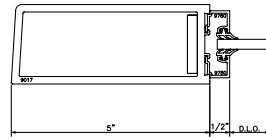
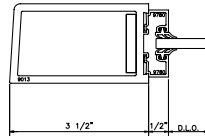

**TOP RAILS**

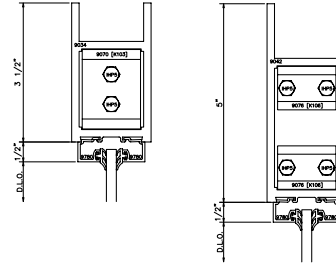

**BOTTOM RAIL**

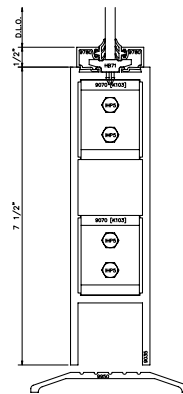

**PERFORMANCE DATA**

**D318 DURASTILE™ MEDIUM STILE  
(SINGLE DOOR LEAF)**

AIR INFILTRATION ..... < .50 CFM/SF @ 1.56 PSF

**D518 DURASTILE™ WIDE STILE  
(SINGLE DOOR LEAF)**

AIR INFILTRATION ..... < .50 CFM/SF @ 1.56 PSF

**D618 DURASTILE™ WIDE STILE  
(SINGLE DOOR LEAF)**

AIR INFILTRATION ..... < .50 CFM/SF @ 1.56 PSF

A = Estimated values and/or designations  
 B = Non-standard size or configuration  
 C = Dual glazed  
 D = 1" Insulated - 1/4" clear, 1/2" air, 1/4" clear  
 E = 1" Insulated - 1/4" clear (Low Emissivity), 1/2" air, 1/4" clear  
 F = 1" Insulated - 1/4" clear (Low Emissivity), 1/2" argon, 1/4" clear  
 G = 1" Insulated - 1/4" clear, 1/2" air, 1/4" clear (Low Emissivity)

D318, D518, & D618 GLAZING CHART	POLYCARBONATE			Glass or Panel										
	3/16"	1/4"	5/16"	1/4"	1/4"***	5/16"	7/16"	1/2"	9/16"	5/8"	3/4"	7/8"	15/16"	1"
MONOLITHIC GLASS	A	A	C	A	A	C	C	C	C	C				
INSULATED GLASS													A	A

\*\* - Laminated Glass Thickness  
 A - Available Glazing Option  
 C - Adaptor and/or gasket required  
 Blank - N/A



## Series D318 Durastile™ Heavy Duty Entrance\* • Series D518 Durastile™ Heavy Duty Entrance\* 2" Heavy Duty Aluminum Swing Entrance Doors

### Door Construction

The rails and stiles have a depth of 2", and are constructed of 6063-T6 aluminum alloy. Nominal material wall thickness is .188". Corner construction utilizes heavy, concealed, reinforcement bracket that is deep penetration and fillet welded. See Illustration 1.

### Frame Construction

The door frame has a depth of 4 1/2", and a sightline of 2". The extrusions are 6063-T6 aluminum alloy. Nominal material wall thickness is .188". Corners incorporate the shear block method of construction.

### Weather-Stripping

Single doors are weather-stripped at the frame with ASTM E2203 compliant bulb gasket and extruded door stops which are available in integral, snap-in, and surface mounted varieties. See frame section. All pairs of doors are dual weather-stripped at the astragal with Poly-Pile®.

### Hardware

EFCO standard doors accommodate most hardware types. Doors accept offset pivots, center pivots, butt hinges, or continuous gear hinges. Maximum security deadbolts, short throw deadbolts, hook bolts, latch locks, and flush bolts are a few of the compatible types of locks. Panic devices include concealed rod devices, rim devices and removable mullions. Concealed overhead, surface mounted and floor closers are accommodated. EFCO ultraline push-pulls are standard.

### Glazing

Doors are glazed with extruded aluminum, pressure fitting glass stops. Glazing of 3/16" to 1 1/16" insulating units are available. See Glazing chart for exact size.

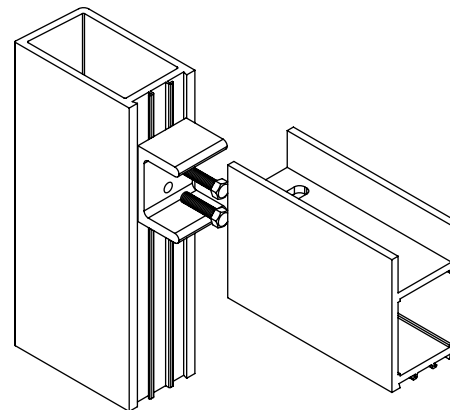
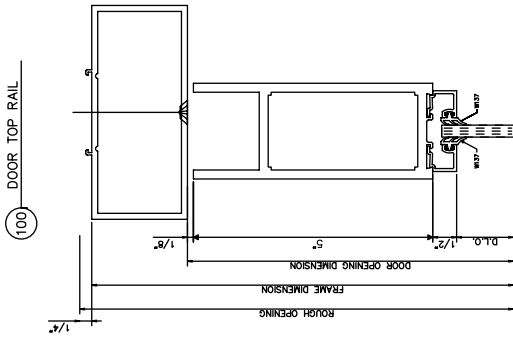

Illustration 1





**D518**



200 DOOR BOTTOM RAIL WITH THRESHOLD

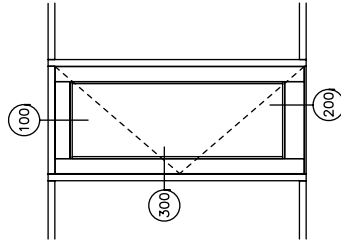
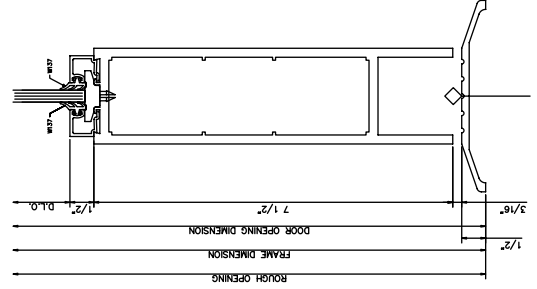

500 LEFT DOOR STILE

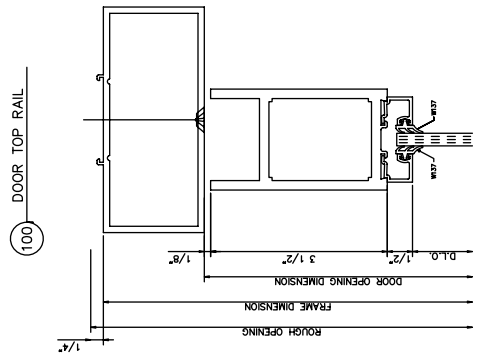
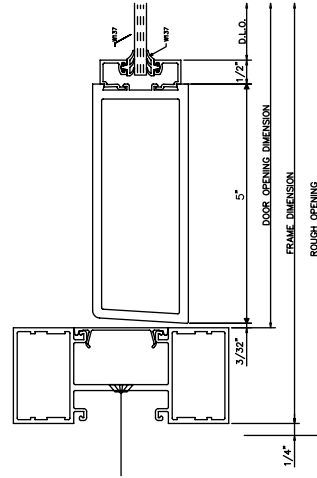

200 DOOR BOTTOM RAIL WITH THRESHOLD

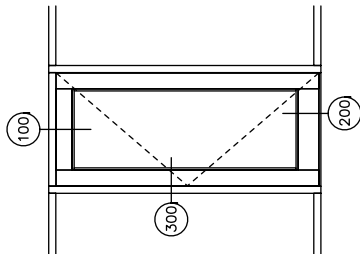
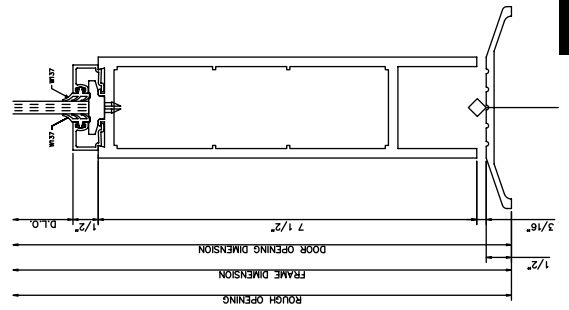

300 LEFT DOOR STILE

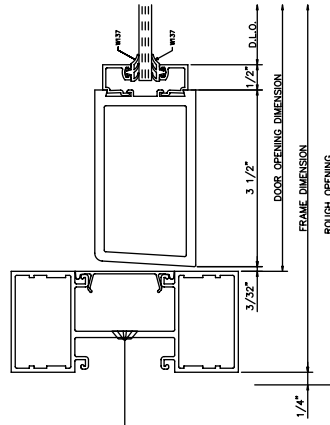

**D318**

1" INSULATED  
1/4" - 1/4"

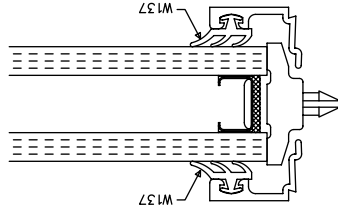

1/2" GLAZE

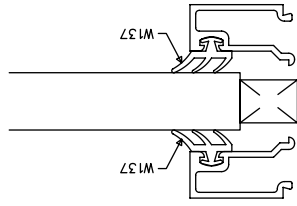

1/4" GLAZE

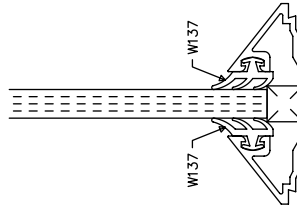

5/8" GLAZE

