

Series D202 Narrow Stile • Series D302 Medium Stile • D502 Wide Stile 2" Thermastile™ Aluminum Swing Entrance Doors



CONFIGURATIONS

Narrow Stile (2 1/4") • Medium Stile (3 1/2") • Wide Stile (5")

EFCO's Thermastile entrances are designed to meet specific applications where security, egress, thermal performance and dual finish capability is required. Thermastile entrances are joint plug welded at every corner to provide superior strength in all applications. Offered in narrow, medium and wide stiles, EFCO standard entrances can accommodate a wide range of applications. Also, multiple glazing options provide flexibility to meet specific design requirements, and the product's ability to accommodate most hardware applications increases its versatility. Thermastile entrances are thermally isolated, enhancing energy saving potential. EFCO's Thermastile entrances provide the complete solution for your fenestration needs.

Features

Benefits

E-Strut™ thermal isolator	Dual finish capability
Exterior corners are true mortise and tenon	Physical interlock between the rails and stiles increases strength of door
Interior corners are joined by concealed reinforcement brackets and deep penetration fillet weld	Improves ability to function correctly in high-usage applications
Accepts most major brands of locking hardware, panic devices, Rixson HD pivots and continuous hinges.	Able to comply with special hardware specifications
Accommodates all surface mounted, concealed overhead and floor closers	Unrestricted closer choices
Tall bottom rails available	Meets ADA requirements
Variety of cross rails, door sweeps, and crash bars available	Increases configuration options
Anodized and painted finishes available	Multiple options to answer economic and aesthetic concerns



Series D202 Narrow Stile • Series D302 Medium Stile • D502 Wide Stile 2" Thermastile™ Aluminum Swing Entrance Doors



PERFORMANCE DATA

D202 NARROW STILE (SINGLE DOOR LEAF)

AIR INFILTRATION	< .50 CFM/SF @ 1.56 PSF
CRF-FRAME (1503.1)	40 ^{A, J}
CRF-GLASS (1503.1)	52 ^{A, J}
U-VALUE (1503.1)	66 ^{A, J}

D302 MEDIUM STILE (SINGLE DOOR LEAF)

AIR INFILTRATION	< .50 CFM/SF @ 1.56 PSF
CRF-FRAME (1503.1)	40 ^{A, J}
CRF-GLASS (1503.1)	52 ^{A, J}
U-VALUE (1503.1)	66 ^{A, J}

D502 WIDE STILE (SINGLE DOOR LEAF)

AIR INFILTRATION	< .50 CFM/SF @ 1.57 PSF
CRF-FRAME (1503.1)	40 ^{A, J}
CRF-GLASS (1503.1)	52 ^{A, J}
U-VALUE (1503.1)	66 ^{A, J}

A = Estimated values and/or designations
 B = Non-standard size or configuration
 C = Dual glazed
 D = 1" Insulated - 1/4" clear, 1/2" air, 1/4" clear
 E = 1" Insulated - 1/4" clear (Low Emissivity), 1/2" air, 1/4" clear
 F = 1" Insulated - 1/4" clear (Low Emissivity), 1/2" argon, 1/4" clear
 G = 1" Insulated - 1/4" clear, 1/2" air, 1/4" clear (Low Emissivity)

D202, D302, AMD D502 GLAZING CHART	POLYCARBONATE			GLASS OR PANEL												
	3/16"	1/4"	5/16"	3/16"	1/4"	1/4"***	5/16"	7/16"	1/2"	9/16"	5/8"	3/4"	7/8"	15/16"	1"	1-1/16"
MONOLITHIC GLASS	C	A	C	C	A	A	C									
INSULATED GLASS														C	A	C

** - Laminated Glass Thickness
 A - Available Glazing Option
 C - Adaptor and/or gasket required
 Blank - N/A



Series D202 Narrow Stile • Series D302 Medium Stile • D502 Wide Stile 2" Thermastile™ Aluminum Swing Entrance Doors

Door Construction

The rails and stiles have a depth of 2", and are constructed of 6063-T6 aluminum alloy. Nominal material wall thickness is .125". The thermal barrier consists of two glass reinforced polyamide nylon struts, mechanically crimped in raceways extruded in the exterior and interior extrusions. Corner construction utilizes a combination of mortise and tenon and a heavy, concealed reinforcement bracket that is deep penetration and fillet welded. All aluminum members have a true thermal barrier. Dual finish capability is available. See Illustration 1.

Frame Construction

The door frame has a depth of 4 1/2", with a sightline of 2". The extrusions are 6063-T6 aluminum alloy. Nominal material wall thickness is .125". The thermal isolator consists of two glass reinforced polyamide nylon struts, mechanically crimped in raceways extruded in the exterior and interior extrusions. Corners incorporate the shear block method of construction. Dual finish capability is available.

Weather-Stripping

Single doors are weather-stripped at the frame with ASTM E2203 compliant bulb gasket and extruded door stops, which are available in integral, snap-in, and surface mounted varieties. See frame section. All pairs of doors are dual weather-stripped at the astragal with Poly-Pile®.

Hardware

EFCO standard doors accommodate most hardware types. Doors accept offset pivots, center pivots, or continuous gear hinges. Maximum security deadbolts, short throw deadbolts, hook bolts, latch locks, and flush bolts are a few of the compatible types of locks. Panic devices include concealed rod devices, rim devices and removable mullions. Concealed overhead, surface mounted and floor closers are accommodated. EFCO Ultraline™ push-pulls are standard. Butt Hinges are not compatible with Thermastile entrances.

Glazing

Doors are glazed with extruded aluminum, pressure fitting glass stops. Glazing of 3/16" to 1 1/16" insulated units are available. See Glazing chart for exact size.

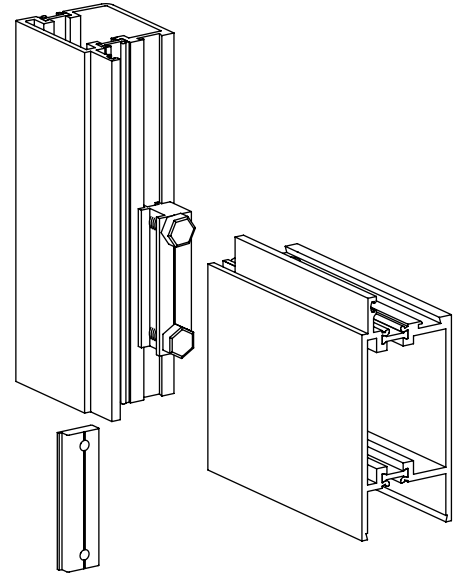
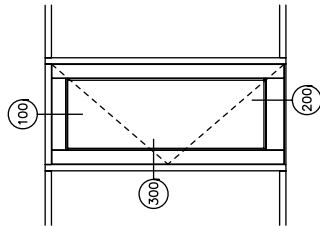
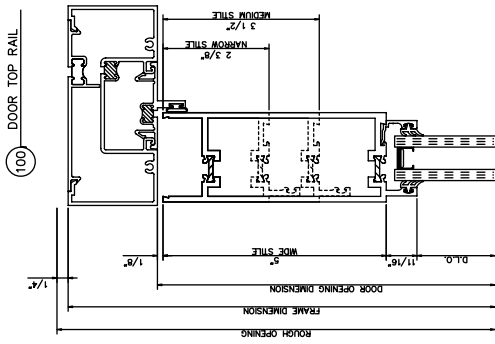

Illustration 1





1/4" GLAZE
2523 INTERIOR
AND EXTERIOR
GRID

5/8" GLAZE
2523 GRID

1/4" GLAZE

