

Series D200 Narrow Stile • Series D300 Medium Stile • D500 Wide Stile 1 3/4" Standard Aluminum Swing Entrance Doors



CONFIGURATIONS

Narrow Stile (2 1/8") • Medium Stile (3 1/2") • Wide Stile (5")

EFCO's standard entrances are designed for educational facilities, shopping centers, offices and other facilities requiring security and egress capabilities. EFCO standard entrances are joint plug welded at every corner to provide superior strength in all applications. Offered in narrow, medium and wide stiles, EFCO standard entrances can accommodate a wide range of applications. Multiple glazing options provide flexibility to meet specific design requirements, and the product's ability to accommodate most hardware applications increases its versatility. EFCO's standard entrances provide the complete solution for your fenestration needs.

Features

- Bracket reinforced and deep penetration welded corners
- Accepts most major brands of locking hardware and panic devices
- Accommodates up to 1" glazing
- Accommodates all surface mounted, concealed overhead and floor closers
- Tall bottom rails available
- Variety of cross rails, door sweeps, and crash bars available
- Anodized and painted finishes available

Benefits

- Meets or exceeds most specifications for commercial entrances
- Able to comply with special hardware specifications
- Flexibility in design requirements for glazing
- Unrestricted closer choices
- Meets ADA requirements
- Increases configuration options
- Multiple options to answer economic and aesthetic concerns



Series D200 Narrow Stile • Series D300 Medium Stile • D500 Wide Stile 1 3/4" Standard Aluminum Swing Entrance Doors

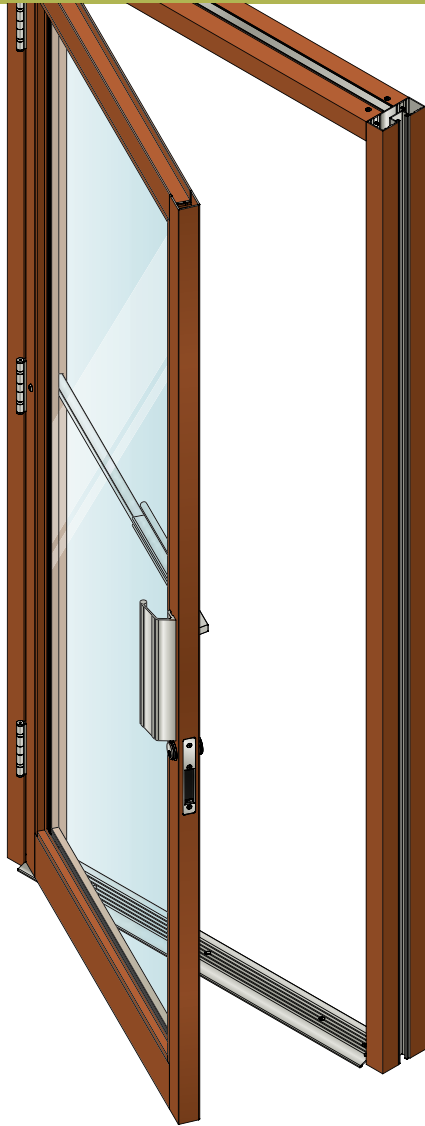

TOP RAILS

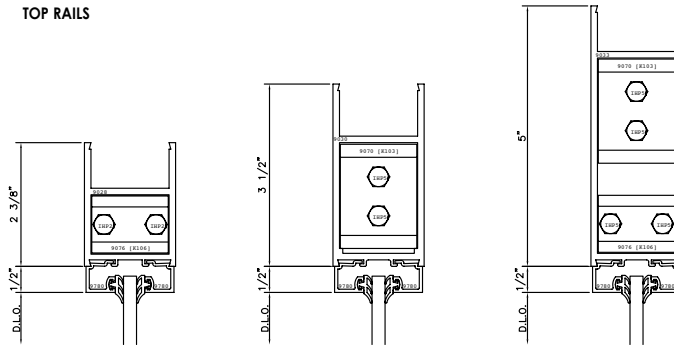

BOTTOM RAILS

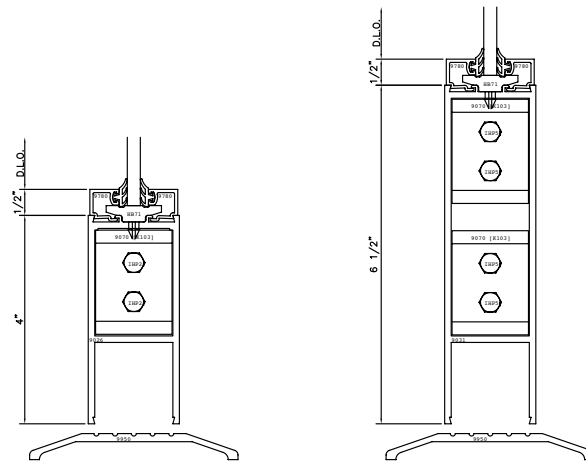

PERFORMANCE DATA

D200 NARROW STILE (SINGLE DOOR LEAF)

AIR INFILTRATION < .50 CFM/SF @ 1.56 PSF

D300 MEDIUM STILE (SINGLE DOOR LEAF)

AIR INFILTRATION < .50 CFM/SF @ 1.56 PSF

D500 WIDE STILE (SINGLE DOOR LEAF)

AIR INFILTRATION < .50 CFM/SF @ 1.56 PSF

A = Estimated values and/or designations
 B = Non-standard size or configuration
 C = Dual glazed
 D = 1" Insulated - 1/4" clear, 1/2" air, 1/4" clear
 E = 1" Insulated - 1/4" clear (Low Emissivity), 1/2" air, 1/4" clear
 F = 1" Insulated - 1/4" clear (Low Emissivity), 1/2" argon, 1/4" clear
 G = 1" Insulated - 1/4" clear, 1/2" air, 1/4" clear (Low Emissivity)

D200, D300, & D500 GLAZING CHART	POLYCARBONATE			GLASS OR PANEL										
	3/16"	1/4"	5/16"	1/4"	1/4"***	5/16"	7/16"	1/2"	9/16"	5/8"	3/4"	7/8"	15/16"	1"
MONOLITHIC GLASS	A	A	C	A	A	A	C	C	C	C				
INSULATED GLASS													A	A

** - Laminated Glass Thickness
 A - Available Glazing Option
 C - Adaptor and/or gasket required
 blank - N/A



Series D200 Narrow Stile • Series D300 Medium Stile • D500 Wide Stile 1 3/4" Standard Aluminum Swing Entrance Doors

Door Construction

Door rails and stiles have a depth of 1 3/4", and are constructed of 6063-T6 aluminum alloy. Nominal material wall thickness is .125". Corner construction utilizes a heavy, concealed, reinforcement bracket that is deep penetration and fillet welded. See Illustration 1.

Weather-Stripping

Single doors are weather-stripped at the frame with ASTM E2203 compliant bulb gasket and extruded door stops, which are available in integral, snap-in, and surface mounted varieties. See frame section. All pairs of doors are dual weather-stripped at the astragal with Poly-Pile.

Hardware

EFCO standard doors accommodate most hardware types. Doors accept offset pivots, center pivots, butt hinges, or continuous gear hinges. Maximum security deadbolts, short throw deadbolts, hook bolts, latch locks, and flush bolts are a few of the compatible types of locks. Panic devices include concealed rod devices, rim devices and removable mullions. Concealed overhead, surface mounted and floor closers are accommodated. EFCO Ultraline™ push-pulls are standard.

Glazing

Doors are glazed with extruded aluminum, pressure fitting glass stops. Glazing of 3/16" to 1 1/16" insulated units are available. See Glazing chart for exact size.

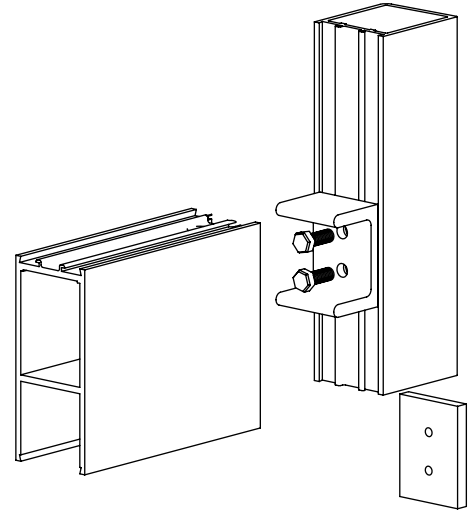
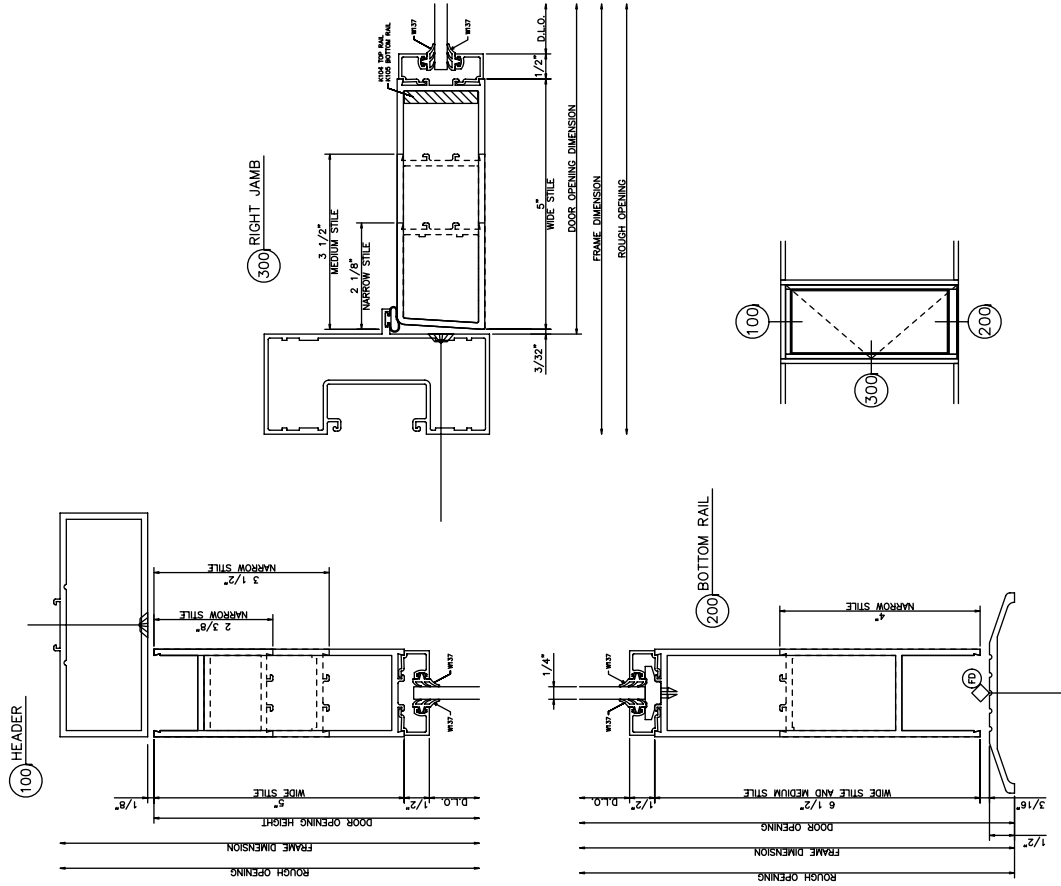
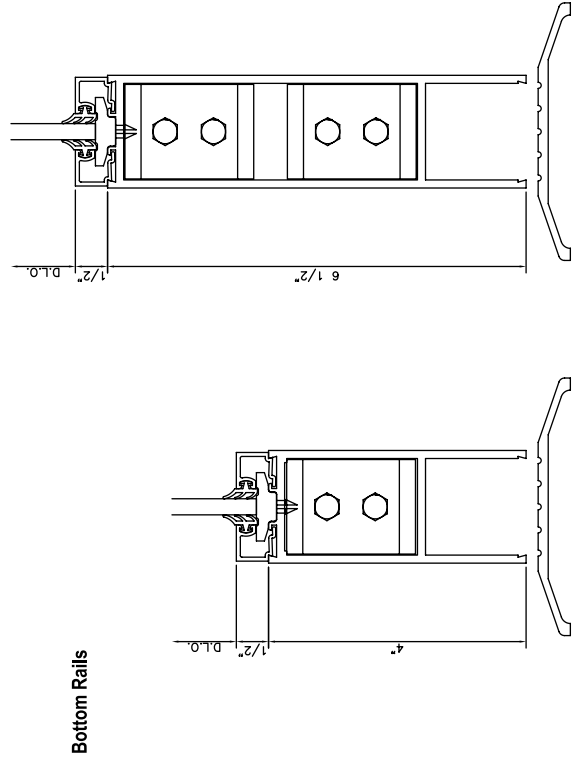
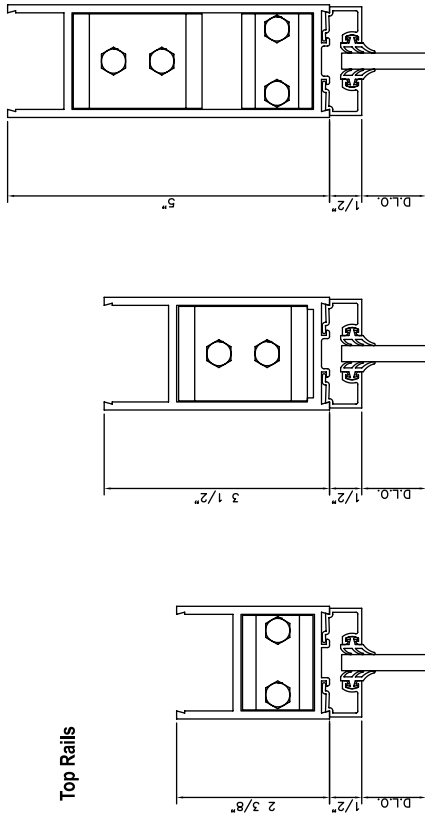

Illustration 1





D200 — D500 Top & Bottom Rails

D200, D300, D500

D200, D300, D500 Glazing

1/2" GLAZING

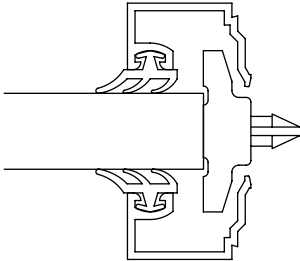

1/4" GLAZING

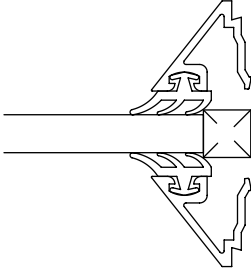

1" GLAZING

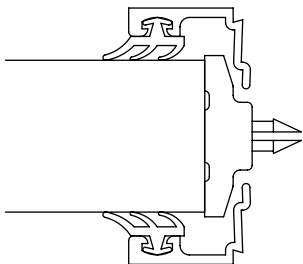

1/4" GLAZING

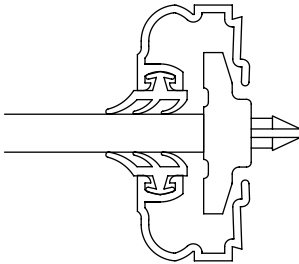

1/4" GLAZING WITH EXTERIOR GRID

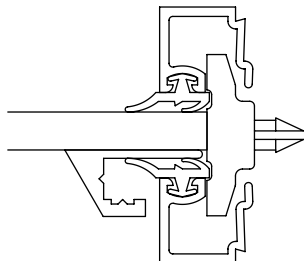

1/4" GLAZING WITH EXTERIOR AND INTERIOR GRID

