

# System 5600

## 2 1/4" Curtain Wall Thermally Improved System



### CONFIGURATIONS

Outside Glazed • Inside Glazed • 2 or 4-sided Structural Glazed • Slope Glazed • Screw Spline

EFCO 2 1/4" system 5600 is the benchmark for value and performance in a pressure wall system. It is offered in a range of system depths and face covers to meet any design specification. Center tongue for outside glazed configurations and offset tongue for inside glazed configurations allows the system to meet the need for labor savings. Available with roll-on horizontals in shear block type applications for decreased fabrication and installation labor, also providing concealed fasteners.

### Features

### Benefits

Thermal Isolator used between exterior and interior extrusions	Improved thermal performance
Various mullion depths and widths available	Provides design flexibility
Wide variety of snap-on face covers	Customize projects with face covers of various depths and profiles
Optional corner mullions	Allows 90° and 135° inside and outside corners
Screw spline construction	Allows assembly of sections prior to installation
	Decreases installation time
Shear block construction	Ability to erect on the job site
Concealed vents	Ability to include ventilation while maintaining the exterior sight line
Integral door adaptors	Compatible with all 1 3/4" and 2" EFCO entrances
Hip and valley rafters are available with the slope glazed system	Enables complex, slope corner transitions
Accommodates up to 1 5/16" glazing	Expands design and energy saving options
Accessory line of perimeter anchors, pocket fillers, door adaptors, etc.	Increased product versatility
Anodized and painted finishes available	Multiple options to answer economic and aesthetic concerns
Roll-on Horizontal	Concealed fasteners; reduce installation labor



# System 5600

## 2 1/4" Curtain Wall Thermally Improved System

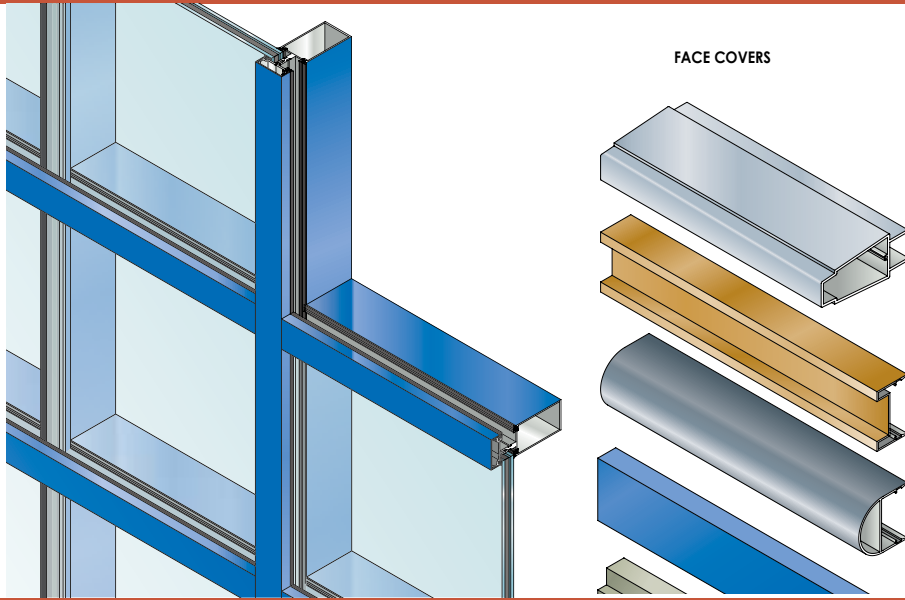

### PERFORMANCE DATA

#### SERIES 5600 OUTSIDE GLAZED CURTAIN WALL

AIR INFILTRATION	<.06 CFM/SF @ 6.24 PSF
WATER	NO LEAKAGE >15.0 PSF
STRUCTURAL	visit MyEFCO at <a href="http://www.efcocorp.com">www.efcocorp.com</a>
CRF-FRAME (1503-98)	67 <sup>F</sup>
CRF-GLASS (1503-98)	69 <sup>F</sup>
STC (E 90-02)	29

#### SERIES 5600 INSIDE GLAZED CURTAIN WALL

AIR INFILTRATION	<.06 CFM/SF @ 6.24 PSF
WATER	NO LEAKAGE @ 15.0 PSF
STRUCTURAL	visit MyEFCO at <a href="http://www.efcocorp.com">www.efcocorp.com</a>
CRF-FRAME (1503-98)	67 <sup>A, F</sup>
CRF-GLASS (1503-98)	69 <sup>A, F</sup>
STC (E 90-02)	29 <sup>A</sup>

A = Estimated values and/or designations
B = Non-standard size or configuration
C = Dual glazed
D = 1" Insulated - 1/4" clear, 1/2" air, 1/4" clear
E = 1" Insulated - 1/4" clear (Low Emissivity), 1/2" argon, 1/4" clear
F = 1" Insulated - 1/4" clear (Low Emissivity), 1/2" argon, 1/4" clear
G = 1" Insulated - 1/4" clear, 1/2" air, 1/4" clear (Low Emissivity)

#### SERIES 5600 CONCEALED VENT

AIR INFILTRATION	<.30 CFM/SF @ 6.24 PSF
WATER	NO LEAKAGE >15.0 PSF
STRUCTURAL	visit MyEFCO at <a href="http://www.efcocorp.com">www.efcocorp.com</a>
CRF-FRAME (1503-98)	57 <sup>F</sup>
CRF-GLASS (1503-98)	63 <sup>F</sup>
U-VALUE (1503-98)	68 <sup>F</sup>
STC (E 90-02)	30

#### SERIES 5600 2-SIDED OR 4-SIDED STRUCTURAL GLAZED CURTAIN WALL

AIR INFILTRATION	<.06 CFM/SF @ 6.24 PSF
WATER	NO LEAKAGE >15.0 PSF
STRUCTURAL	visit MyEFCO at <a href="http://www.efcocorp.com">www.efcocorp.com</a>
CRF-FRAME (1503-98)	67 <sup>A, F</sup>
CRF-GLASS (1503-98)	69 <sup>A, F</sup>
STC (E 90-02)	29 <sup>A</sup>

#### SERIES 5600 SLOPE GLAZED CURTAIN WALL

AIR INFILTRATION	<.06 CFM/SF @ 6.24 PSF
WATER	NO LEAKAGE @ 10.0 PSF
STRUCTURAL	visit MyEFCO at <a href="http://www.efcocorp.com">www.efcocorp.com</a>
CRF-FRAME (1503-98)	67 <sup>A, E</sup>
CRF-GLASS (1503-98)	69 <sup>A, E</sup>
STC (E 90-02)	29 <sup>A</sup>

EFCO CERTIFIES SERIES 5600 2, 2 1/2, 3, 4, 5, AND 6" WIDE SYSTEMS MEET THE ABOVE AIR (ASTM E 283) AND WATER (ASTM E 331) PERFORMANCE. CONTACT EFCO FOR MORE INFORMATION.

AVAILABLE SYSTEM DEPTHS	SYSTEM DEPTH				
	5"	6"	7"	8"	9"
OUTSIDE GLAZED	A	A	A	A	A
INSIDE GLAZED	A	A	A	A	A
2- AND 4-SIDED STRUCTURAL GLAZED	A	A	A	A	A
SLOPE GLAZED	A	A	A	A	A

A - Available System Depth  
Blank - N/A

CENTER OF GLASS U-FACTOR	5600 THERMAL U-FACTORS*	
	CONFIGURATION AND SIZE	
	FX / FX** 78 3/4" X 78 3/4"	FX / FX 120" X 120"
0.46	0.63	0.51
0.34	0.53	0.45
0.30	0.50	0.42
0.24	0.45	0.36
0.20	0.42	0.33

\* Based on NFRC 100  
\*\*NFRC Gateway size

INTEGRAL S-5600 GLAZING CHART		POLYCARBONATE			GLASS OR PANEL																	
		1/8"	3/16"	1/4"	1/8"	.156"	3/16"	.200"	1/4"	1/4"	1/2"	5/8"	3/4"	7/8"	1"	1-1/8"	1-1/4"	1-1/2"	1-3/4"	2"		
OUTSIDE GLAZED	MONOLITHIC GLASS	C	C	A	C	C	C	C	A	A	A	C	C	C								
	INSULATED GLASS														A	C	A					
INSIDE GLAZED	MONOLITHIC GLASS			A					A	A	A											
	INSULATED GLASS													A		A						
STRUCTURAL GLAZED	MONOLITHIC GLASS			A					A	A	A											
	INSULATED GLASS													A								
SLOPE GLAZED	MONOLITHIC GLASS			A					A	A	A											
	INSULATED GLASS													A								

\*-Obscure Glass Thickness  
\*\*-Laminated Glass Thickness

A - Available Glazing Option  
C - Custom pressure plate, adaptor and/or gasket required  
Blank - N/A



# System 5600

## 2 1/4" Curtain Wall Thermally Improved System

### Main Frame Construction

System 5600 curtain wall has various system depths. Sight lines are nominally 2 1/4" and present a clean, attractive appearance. Members are extruded from 6063-T6 aluminum alloy, and the nominal material wall thickness is .093" to .125". Joint construction utilizes the shear block method. See Illustration 1.

### Concealed Vent Construction

System 5600 curtain wall has optional concealed vents that utilize screw spline construction.

### Thermal Barrier

System 5600 curtain wall members are thermally improved using vinyl gasket to isolate exterior and interior extrusions.

### Sunshade Information

System 5600 curtain wall has optional sunshades available in five standard depths. Sunshade blades available in various sizes. Members are extruded from 6063-T6 aluminum alloy. Sunshade clips and arms are fabricated on a CNC machine. Joint construction utilizes screw spline construction.

\*Note: Structural design loads will determine the sunshade depth and clip spacing limitations.

### Glazing

System 5600 curtain wall can be glazed from the interior or the exterior. It is "dry glazed" with preset and drive-in EPDM gasket. Series 5600 accommodates 1/4" to 1 1/4" infill panels. Dual glazing is available with internal blinds.

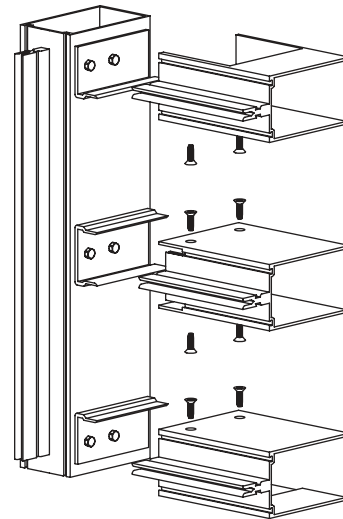
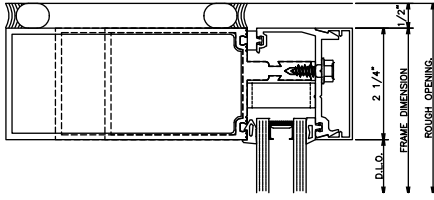

Illustration 1





481 JAMB



640 VERTICAL

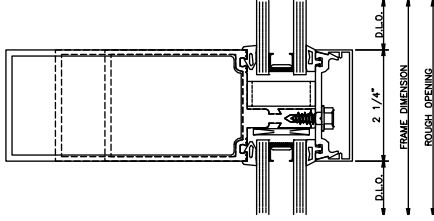

480 JAMB

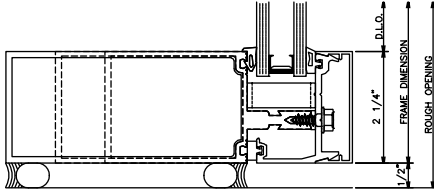

140 HEAD

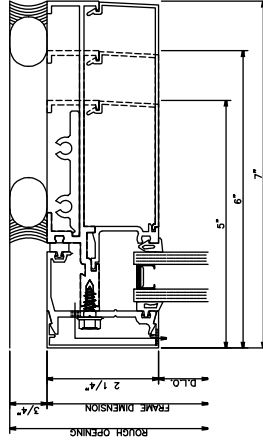

540 HORIZONTAL

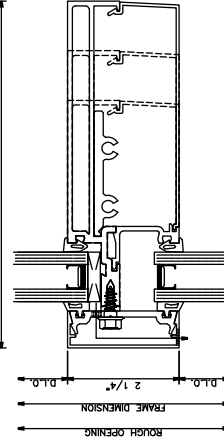

540 SILL

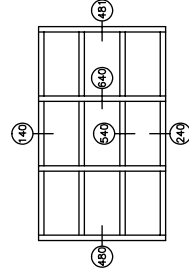
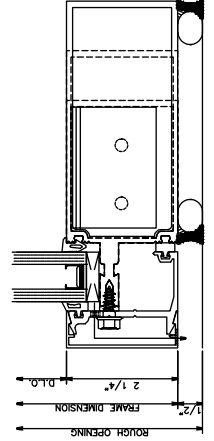

439 RIGHT JAMB

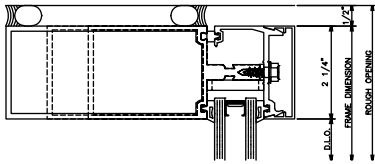

619 VERTICAL

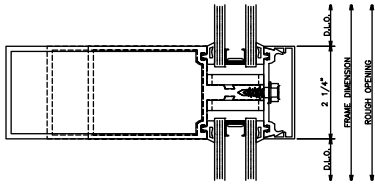

439 LEFT JAMB

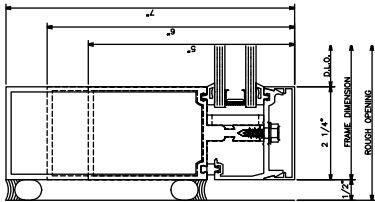

119 HEAD

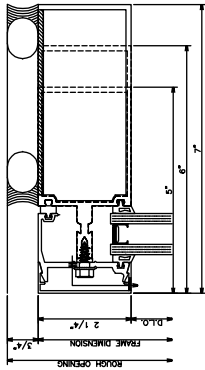

519 HORIZONTAL

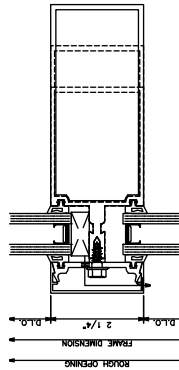

520 OPTIONAL HORIZONTAL

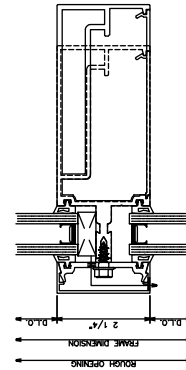

219 SILL

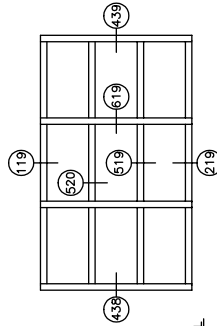
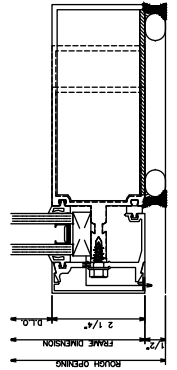

**2-1/4" 5600 Center Tongue**

2-1/4" x 5", 6", 7"

**2-1/4" 5600 Inside Glazed**

2-1/4" x 5", 6", 7"

**2-1/4" 5600 Screw Spline**

2-1/4" x 5", 6", 7"

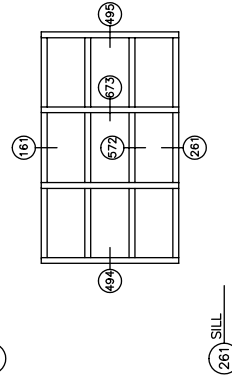
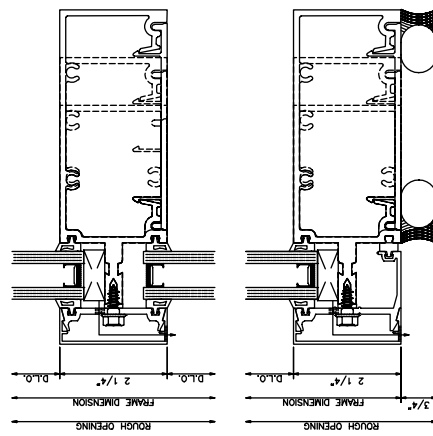
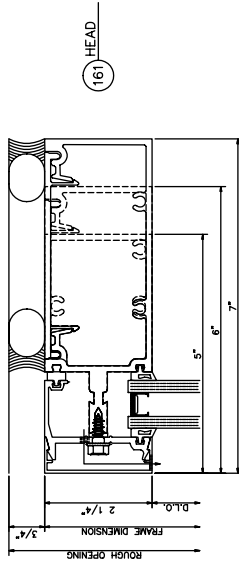
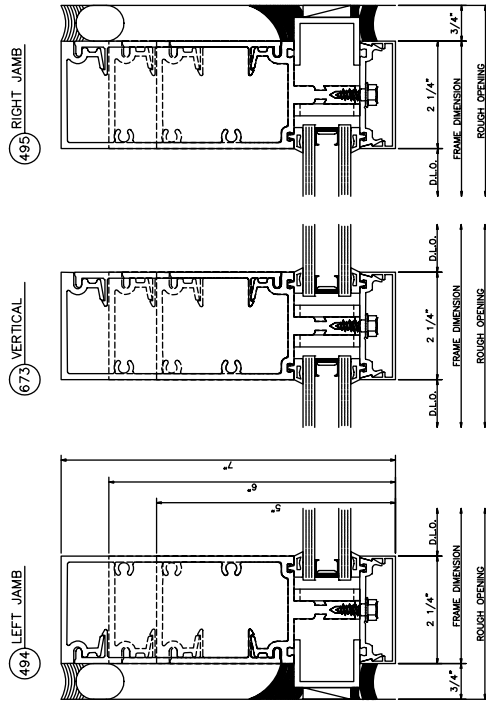

**2-1/4" 5600 Corner**

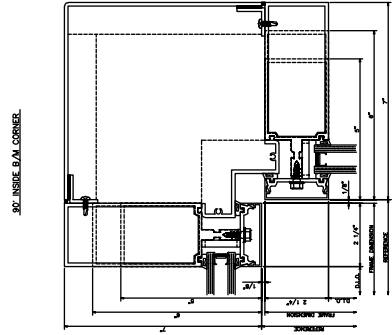
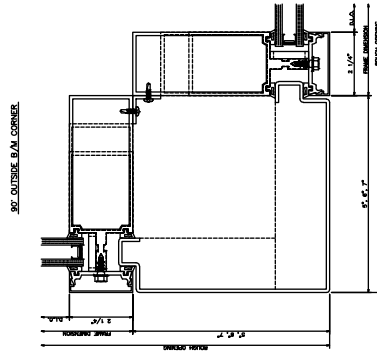
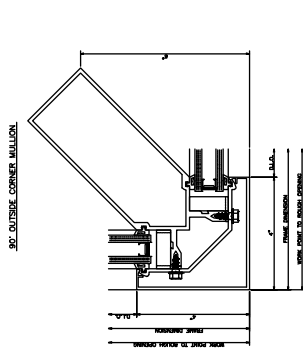

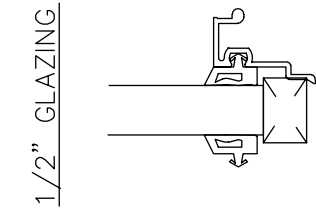
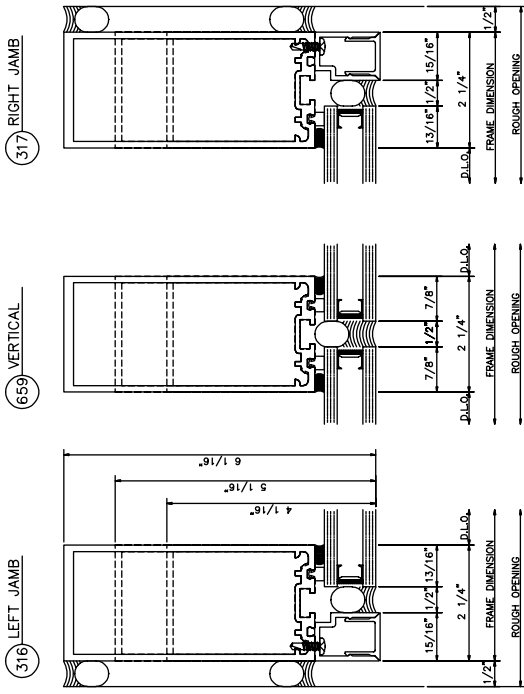

1/2" GLAZING

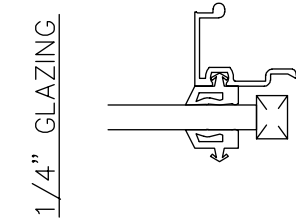

1/4" GLAZING

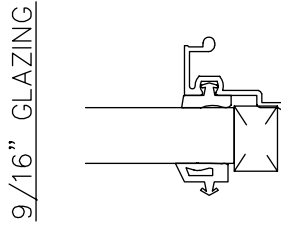

9/16" GLAZING

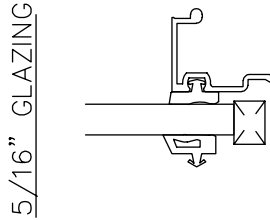

5/16" GLAZING

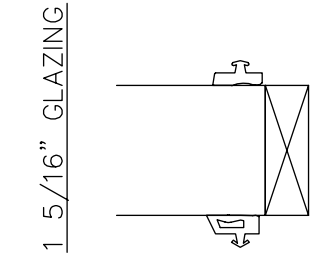
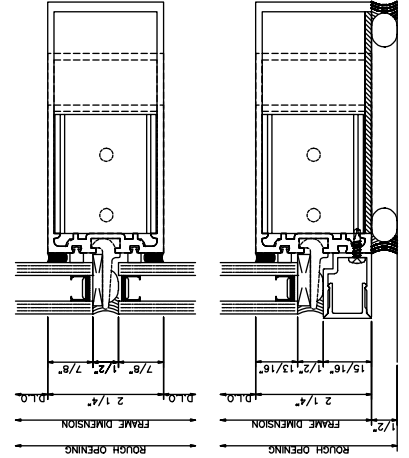

1 5/16" GLAZING

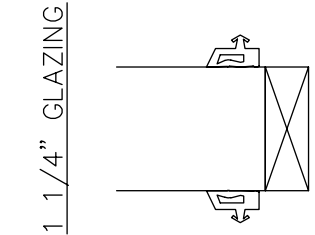

1 1/4" GLAZING

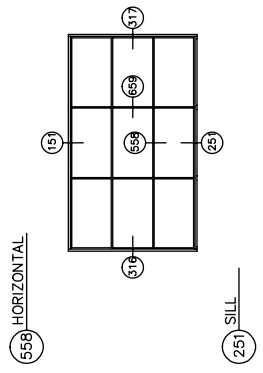

**2-1/4" 5600 Center Tongue Glazing**

**2-1/4" 5600 Structural Glazed**

**2-1/4" 5600 Structural Glazed Covers**

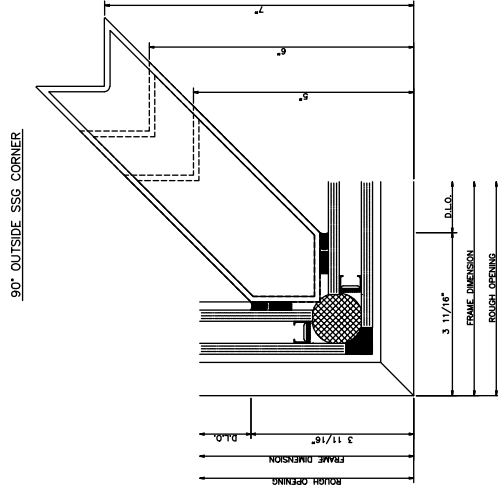

90° INSIDE SSG CORNER

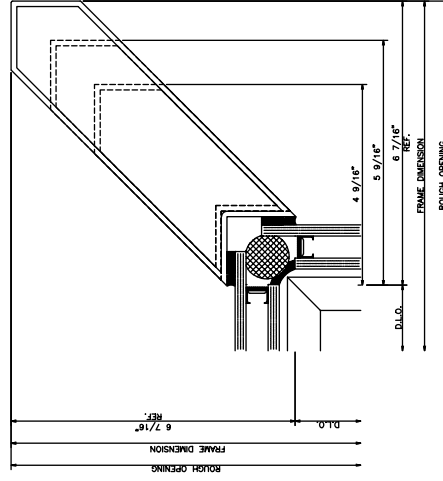

**2-1/4" 5600 Structural Glazing Option**

1/4" GLAZING

