

DOUBLE-HUNG

SECTION DIRECTORY



General Information

Product Summary	F-DH-2
Size and Performance Data.....	F-DH-3
Sound Transmission Class.....	F-DH-3
Features and Options	F-DH-4
Glazing Performance.....	F-DH-5

Product Details

Combination Assemblies.....	F-DH-7
Grille Types.....	F-DH-8
Size Tables	F-DH-9
Design Data.....	F-DH-14
Detailed Product Descriptions.....	F-DH-20
Unit Sections	F-DH-20
Typical Joining Mullions	F-DH-22
Integral Nailing Fin.....	F-DH-23

General Notes:

Specifications subject to change without notice. Go to www.PellaADM.com for most current technical data.
For complete CSI Format Specifications see www.PellaADM.com.

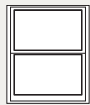

DOUBLE-HUNG

BRAND SUMMARY



Pella® Impervia® Double-Hung

windows are traditional in every detail—with all the Pella innovations you demand. Both frame types and sash material feature Duracast® fiberglass composite, Pella’s patented, five layer, engineered fiberglass composite. Duracast fiberglass composite is the strongest, most durable material available in windows and doors. Each window uses three-way reinforced corners for increased strength. All frame and sash corners are locked in place with corner locks and injected with a dual purpose sealant/adhesive for long-lasting performance. Frame corners are additionally secured with mechanical fasteners. Pella Impervia products are prefinished with powder-coat paint. This paint meets the stringent AAMA 623 standards. Powder-coat paint is resistant to dents, scratches and damaging UV light. Duracast fiberglass composite withstands extreme heat (over 200° F), intense cold (-40° F), and is seacoast worthy. Pella Impervia products exceed industry standards for water infiltration and wind resistance.



BLOCK FRAME

The 3" deep block frame is our most versatile frame. Units can be installed in masonry openings using installation clips, concealed jamb screws or in wood frame openings using optional fins. Units can also be field-jointed together. Our block frames may easily be used as a replacement window without removing the existing frame or damaging the exterior.

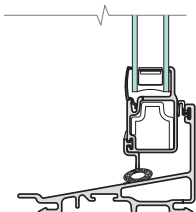

PRECISION FIT®

Precision Fit Window System is a fully assembled, factory-tested double-hung window unit that slides easily into the existing sash "pocket" created when the old sash is removed. This is done without damaging surrounding trim, wall paper, paint or plaster. Custom-built units are made to order in 1/4" increments to fit your existing window opening.

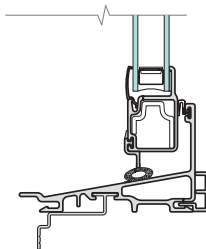

INTEGRAL NAILING FIN

The integral nailing fin features a standard continuous fin, adding a protective weather barrier to the frame itself and allowing for hassle-free installation.

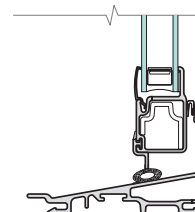

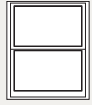

DOUBLE-HUNG

PRODUCT SELECTION GUIDE

Size and Performance Data
Sound Transmission Class



	BLOCK FRAME	PRECISION FIT	INTEGRAL NAILING FIN
SIZES			
Standard Vent – Equal Sash, Cottage and Contemporary Sash	●	●	●
Special Fixed	●	●	●
Special Fixed Companion	●	●	●
Special Sizes Available	●	●	●
PERFORMANCE 1			
Meets or Exceeds AAMA/WDMA Ratings	H-LC30-H-LC50 Hallmark Certified	H-LC30-H-LC50 Hallmark Certified	H-LC30-H-LC50 Hallmark Certified
Air Infiltration (cfm/ft ² of frame @ 1.57 psf wind pressure)	0.3	0.3	0.3
Water Resistance	4.5 psf	4.5 psf	4.5 psf
Design Pressure	30-50 psf	30-50 psf	30-50 psf
OTHER PERFORMANCE CRITERIA			
Forced Entry Resistance Level (Minimum Security Grade) ₂	10	10	10
Maximum Operating Force (lb) Initiate Motion/Maintain Motion	20/30 for units with sash ≤ 12 ft ² 30/45 for units with sash > 12 ft ²		
Maximum Locking Force (lb) Lock/Unlock	6/7	6/7	6/7

Sound Transmission Class and Outdoor-Indoor Transmission Class

Frame Size Tested ³	Glazing System			STC Rating	OITC Rating
	Overall Glazing Thickness	Exterior Glass Thickness	Interior Glass Thickness		
DOUBLE-HUNG - DUAL PANE INSULATING GLASS					
47-1/2" x 77-1/2"	11/16"	2.5 mm	2.5 mm	24	21

S = Standard; O = Optional

(1) See Design Data pages in this section for specific product performance class and grade values.

(2) The higher the level, the greater the product's ability to resist forced entry.

(3) ASTM E 1425 defines standard sizes for acoustical testing. Ratings achieved at that size are representative of all sizes of the same configuration.

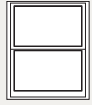

DOUBLE-HUNG

PRODUCT SELECTION GUIDE

Features and Options



	BLOCK FRAME	PRECISION FIT	INTEGRAL NAILING FIN
GLAZING			
Glazing Type			
Dual-pane Insulating Glass	S	S	S
Insulated Glass Options / Low-E Types			
Clear Insulating Glass (no Low-E coating)	S	S	S
Advanced Low-E Insulating Glass	O	O	O
SunDefense™ Low-E Insulating Glass	O	O	O
AdvancedComfort Low-E Insulating Glass	O	O	O
NaturalSun Low-E Insulating Glass	O	O	O
Additional Glass Options			
Annealed Glass	S	S	S
Tempered Glass	O	O	O
Obscure Glass ¹	O	O	O
Gas Fill / High Altitude			
Argon	S	S	S
High Altitude	O	O	O
High Altitude with argon	O	O	O
EXTERIOR			
Powder-Coat White	S	S	S
Powder-Coat Tan, Brown, Black, or Morning Sky Gray	O	O	O
Dual-color (All exterior colors available with White interior)	O	O	–
HARDWARE			
Match interior finish	S	S	S
Satin Nickel, Bright Brass or Oil-Rubbed Bronze	O	O	O
Sash Locks			
Self-aligning sash lock	S	S	S
SCREENS			
Full or Half-Size Conventional Black Fiberglass	O	O	O
Full or Half-Size Inview™ screens	O	O	O
GRILLES			
Grilles-Between-the-Glass			
3/4" Contoured White, Tan, Brown, Black, or Morning Sky Gray	O	O	O
Patterns			
Traditional	O	O	O
Prairie	O	O	O
Top Row	O	O	O
Special	O	O	O
TILT-WASH CLEANING			
Both sashes tilt at bottom	S	S	S

S = Standard; O = Optional; (–) = Not available

(1) Contact your local Pella sales representative for current offering.

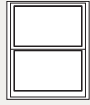

DOUBLE-HUNG

GLAZING PERFORMANCE - TOTAL UNIT

Vent



Glass Thickness	Type of Glazing	NFRC Certified Product #	Glass (mm)		Gap Fill	Performance Values ₁				Shaded Areas Meet ENERGY STAR® Performance Criteria in Zones Shown									
			Ext.	Int.		U-Factor	SHGC	VLT %	CR	U. S.				Canada ₂					
										Zone				ER	Zone				
										N	NC	SC	S			1	2	3	
11/16"	Clear IG	PEL-N-126-00441-00001	2.5	2.5	air	0.48	0.59	62	43										
	with grilles-between-the-glass	PEL-N-126-00442-00001				0.48	0.53	55	43										
11/16"	Clear IG	PEL-N-126-00441-00003	3	3	air	0.48	0.58	61	43										
	with grilles-between-the-glass	PEL-N-126-00442-00003				0.48	0.52	54	43										
11/16"	Advanced Low-E IG	PEL-N-126-00471-00001	2.5	2.5	argon	0.31	0.28	52	57										
	with grilles-between-the-glass	PEL-N-126-00472-00001				0.31	0.25	47	57										
11/16"	Advanced Low-E IG	PEL-N-126-00471-00003	3	3	argon	0.31	0.28	52	57										
	with grilles-between-the-glass	PEL-N-126-00472-00003				0.31	0.25	46	57										
11/16"	SunDefense™ IG	PEL-N-126-00483-00001	2.5	2.5	argon	0.30	0.21	49	58										
	with grilles-between-the-glass	PEL-N-126-00484-00001				0.30	0.19	43	58										
11/16"	SunDefense™ IG	PEL-N-126-00483-00003	3	3	argon	0.30	0.21	48	58										
	with grilles-between-the-glass	PEL-N-126-00484-00003				0.30	0.19	43	58										
11/16"	AdvancedComfort Low-E IG	PEL-N-126-00507-00001	2.5	2.5	argon	0.27	0.28	51	45							20			
	with grilles-between-the-glass	PEL-N-126-00508-00001				0.27	0.25	46	45							18			
11/16"	AdvancedComfort Low-E IG	PEL-N-126-00507-00003	3	3	argon	0.27	0.27	51	45							19			
	with grilles-between-the-glass	PEL-N-126-00508-00003				0.27	0.25	45	45							18			
11/16"	NaturalSun Low-E IG	PEL-N-126-00459-00002	2.5	2.5	argon	0.32	0.52	59	57							27			
	with grilles-between-the-glass	PEL-N-126-00460-00002				0.32	0.47	53	57										
11/16"	NaturalSun Low-E IG	PEL-N-126-00459-00006	3	3	argon	0.32	0.51	59	57							27			
	with grilles-between-the-glass	PEL-N-126-00460-00006				0.32	0.46	52	57										
VENT UNITS – WITH FOAM INSULATION																			
11/16"	Advanced Low-E IG	PEL-N-126-00555-00001	2.5	2.5	argon	0.29	0.28	52	58										
	with grilles-between-the-glass	PEL-N-126-00556-00001				0.29	0.25	47	58										
11/16"	Advanced Low-E IG	PEL-N-126-00555-00003	3	3	argon	0.29	0.28	52	58										
	with grilles-between-the-glass	PEL-N-126-00556-00003				0.29	0.25	46	58										
11/16"	SunDefense IG	PEL-N-126-00567-00001	2.5	2.5	argon	0.28	0.21	49	58										
	with grilles-between-the-glass	PEL-N-126-00568-00001				0.28	0.19	43	58										
11/16"	SunDefense IG	PEL-N-126-00567-00003	3	3	argon	0.28	0.21	48	58										
	with grilles-between-the-glass	PEL-N-126-00568-00003				0.28	0.19	43	58										
11/16"	AdvancedComfort Low-E IG	PEL-N-126-00591-00001	2.5	2.5	argon	0.25	0.28	51	46							22			
	with grilles-between-the-glass	PEL-N-126-00592-00001				0.25	0.25	46	46							20			
11/16"	AdvancedComfort Low-E IG	PEL-N-126-00591-00003	3	3	argon	0.25	0.27	51	46							22			
	with grilles-between-the-glass	PEL-N-126-00592-00003				0.25	0.25	45	46							20			
11/16"	NaturalSun Low-E IG	PEL-N-126-00543-00002	2.5	2.5	argon	0.30	0.52	59	57							30			
	with grilles-between-the-glass	PEL-N-126-00544-00002				0.30	0.47	53	57							27			
11/16"	NaturalSun Low-E IG	PEL-N-126-00543-00006	3	3	argon	0.30	0.51	59	57							29			
	with grilles-between-the-glass	PEL-N-126-00544-00006				0.30	0.46	52	57							26			

R-Value = 1/U-Factor
 SHGC = Solar Heat Gain Coefficient
 VLT % = Visible Light Transmission
 CR = Condensation Resistance
 ER = Canadian Energy Rating

(1) Glazing performance values are calculated based on NFRC 100, NFRC 200 and NFRC 500. ENERGY STAR® values are updated to 2015 (Version 6) criteria.
 (2) The values shown are based on Canada's updated ENERGY STAR® 2015 initiative. For center-glass values, see the Product Performance section.
 See the Product Performance section for more detailed information or visit www.energystar.gov for Energy Star guidelines.

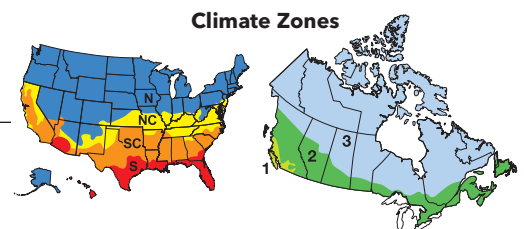

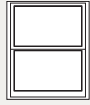

DOUBLE-HUNG

GLAZING PERFORMANCE - TOTAL UNIT

High Altitude Glazing



Glass Thickness	Type of Glazing	NFRC Certified Product #	Glass (mm)		Gap Fill	Performance Values ₁				Shaded Areas Meet ENERGY STAR® Performance Criteria in Zones Shown									
			Ext.	Int.		U-Factor	SHGC	VLT %	CR	U. S.				Canada ₂					
										Zone				ER	Zone				
										N	NC	SC	S				1	2	3
HIGH ALTITUDE GLAZING																			
11/16"	(HA) Advanced Low-E IG	PEL-N-126-00465-00001	2.5	2.5	air	0.35	0.28	52	54										
	with grilles-between-the-glass	PEL-N-126-00466-00001				0.35	0.25	47	54										
11/16"	(HA) Advanced Low-E IG	PEL-N-126-00465-00003	3	3	air	0.35	0.28	52	54										
	with grilles-between-the-glass	PEL-N-126-00466-00003				0.35	0.25	46	54										
11/16"	(HA) SunDefense IG	PEL-N-126-00477-00001	2.5	2.5	air	0.34	0.21	49	54										
	with grilles-between-the-glass	PEL-N-126-00478-00001				0.34	0.19	43	54										
11/16"	(HA) SunDefense IG	PEL-N-126-00477-00003	3	3	air	0.34	0.21	48	54										
	with grilles-between-the-glass	PEL-N-126-00478-00003				0.34	0.19	43	54										
11/16"	(HA) AdvancedComfort Low-E IG	PEL-N-126-00501-00001	2.5	2.5	air	0.30	0.28	51	42										
	with grilles-between-the-glass	PEL-N-126-00502-00001				0.30	0.25	46	42										
11/16"	(HA) AdvancedComfort Low-E IG	PEL-N-126-00501-00003	3	3	air	0.30	0.27	51	42										
	with grilles-between-the-glass	PEL-N-126-00502-00003				0.30	0.25	45	42										
11/16"	(HA) NaturalSun Low-E IG	PEL-N-126-00453-00002	2.5	2.5	air	0.35	0.52	59	53										
	with grilles-between-the-glass	PEL-N-126-00454-00002				0.35	0.47	53	53										
11/16"	(HA) NaturalSun Low-E IG	PEL-N-126-00453-00006	3	3	air	0.35	0.51	59	53										
	with grilles-between-the-glass	PEL-N-126-00454-00006				0.35	0.46	52	53										
HIGH ALTITUDE GLAZING																			
11/16"	(HA) Advanced Low-E IG	PEL-N-126-00549-00001	2.5	2.5	air	0.33	0.28	52	54										
	with grilles-between-the-glass	PEL-N-126-00550-00001				0.33	0.25	47	54										
11/16"	(HA) Advanced Low-E IG	PEL-N-126-00549-00003	3	3	air	0.33	0.28	52	54										
	with grilles-between-the-glass	PEL-N-126-00550-00003				0.33	0.25	46	54										
11/16"	(HA) SunDefense IG	PEL-N-126-00561-00001	2.5	2.5	air	0.32	0.21	49	54										
	with grilles-between-the-glass	PEL-N-126-00562-00001				0.32	0.19	43	54										
11/16"	(HA) SunDefense IG	PEL-N-126-00561-00003	3	3	air	0.32	0.21	48	54										
	with grilles-between-the-glass	PEL-N-126-00562-00003				0.32	0.19	43	54										
11/16"	(HA) AdvancedComfort Low-E IG	PEL-N-126-00585-00001	2.5	2.5	air	0.28	0.28	51	42						18				
	with grilles-between-the-glass	PEL-N-126-00586-00001				0.28	0.25	46	42						17				
11/16"	(HA) AdvancedComfort Low-E IG	PEL-N-126-00585-00003	3	3	air	0.28	0.27	51	42						18				
	with grilles-between-the-glass	PEL-N-126-00586-00003				0.28	0.25	45	42						17				
11/16"	(HA) NaturalSun Low-E IG	PEL-N-126-00537-00002	2.5	2.5	air	0.33	0.52	59	54						26				
	with grilles-between-the-glass	PEL-N-126-00538-00002				0.33	0.47	53	54										
11/16"	(HA) NaturalSun Low-E IG	PEL-N-126-00537-00006	3	3	air	0.33	0.51	59	54						25				
	with grilles-between-the-glass	PEL-N-126-00538-00006				0.33	0.46	52	54										

R-Value = 1/U-Factor
 SHGC = Solar Heat Gain Coefficient
 VLT % = Visible Light Transmission
 CR = Condensation Resistance
 ER = Canadian Energy Rating

(1) Glazing performance values are calculated based on NFRC 100, NFRC 200 and NFRC 500. ENERGY STAR® values are updated to 2015 (Version 6) criteria.

(2) The values shown are based on Canada's updated ENERGY STAR® 2015 initiative.

For center-glass values, see the Product Performance section.

See the Product Performance section for more detailed information or visit www.energystar.gov for Energy Star guidelines.

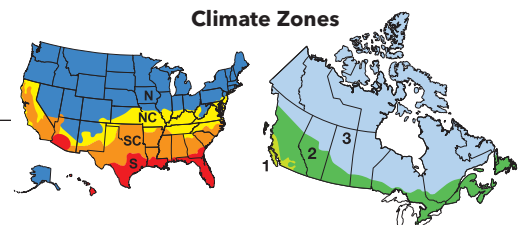

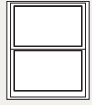

DOUBLE-HUNG

COMBINATION ASSEMBLIES

Special Size Frame Dimensions



Below are available factory-assembled combination assemblies using joining mullions. See the PellaADM.com site, Installation Systems section for requirements and limitations related to mulling various combinations plus configurations size range information.

A combination is defined as an assembly formed by two or more separate windows or doors whose frames are mulled together utilizing a combination mullion or reinforcing mullion.

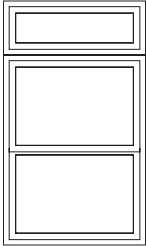
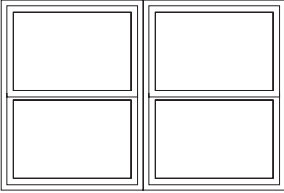
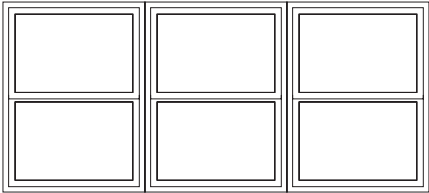
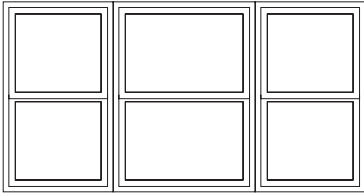
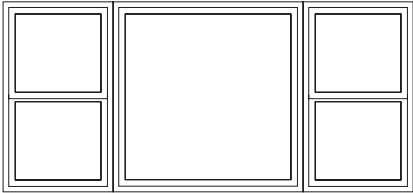
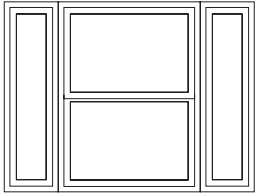
TRANSOM OVER DOUBLE-HUNG	2-WIDE	3-WIDE
 <p>MINIMUM 1' 5-1/2" W x 3' 7" H (445 x 1 092)</p> <p>MAXIMUM 3' 11-1/2" W x 8' 5" H (1 219 x 2 565)</p>	 <p>MINIMUM 2' 11-1/2" W x 2' 5-1/2" H (914 x 762)</p> <p>MAXIMUM 7' 11" W x 5' 5-1/2" H (2 413 x 1 676)</p>	 <p>MINIMUM 4' 4-1/2" W x 2' 5-1/2" H (1 346 x 762)</p> <p>MAXIMUM 8' 10-1/2" W x 5' 5-1/2" H (2 718 x 1 676)</p>
3-WIDE WITH UNEQUAL CENTER	3-WIDE WITH CENTER FIXED	3-WIDE WITH FIXED FLANKERS
 <p>MINIMUM 4' 1/2" W x 2' 5-1/2" H (1 245 x 762)</p> <p>MAXIMUM 8' 10-1/2" W x 5' 5-1/2" H (2 718 x 1 676)</p>	 <p>MINIMUM 4' 1/2" W x 2' 11-1/2" H (1 245 x 914)</p> <p>MAXIMUM 8' 11-1/2" W x 4' 11-1/2" H (2 743 x 1 524)</p> <p>Center Unit Width ≤ 4' 11-1/2"</p>	 <p>MINIMUM 3' 8-1/2" W x 2' 11-1/2" H (1 143 x 914)</p> <p>MAXIMUM 6' 2-1/2" W x 4' 11-1/2" H (1 905 x 1 524)</p>

General Notes:

- To convert areas to square meters (m2), multiply square feet by 0.0929.
- Rough Opening = Frame Dimension + 1/2".
- Keep frame dimensions to the nearest 1/4" increment

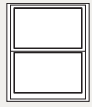

DOUBLE-HUNG

GRILLE TYPES

Grilles-Between-the-Glass



Grille Profiles

GRILLES-BETWEEN-THE-GLASS

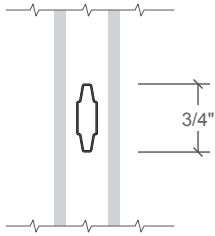

3/4" Contoured

Grille Patterns

PRAIRIE LITE PATTERNS

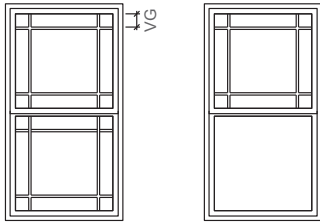

9-Lite Prairie

Prairie

- Standard corner lite dimension for Prairie patterns = 4" visible glass (VG).
- Pattern availability may vary depending on size of unit.

OTHER PATTERNS

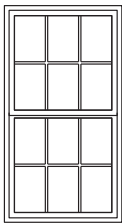

Traditional

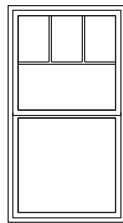

Top Row¹

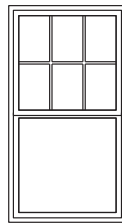

Special

- Pattern availability may vary depending on size of unit.

(1) Standard visible glass to center line of separator bar = 14" or half of total visible glass height, whichever is smaller. Multiple rows are available up to 50% glass size.

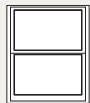

DOUBLE-HUNG

SIZE TABLES

Fixed Transoms and Vent Units



Fixed Transoms

	(457) (445)	(610) (597)	(711) (699)	(762) (749)	(813) (800)	(914) (902)	(1 016) (1 003)	(1 067) (1 054)	(1 219) (1 207)
Opening	1' 6"	2' 0"	2' 4"	2' 6"	2' 8"	3' 0"	3' 4"	3' 6"	4' 0"
Frame	1' 5 1/2"	1' 11 1/2"	2' 3 1/2"	2' 5 1/2"	2' 7 1/2"	2' 11 1/2"	3' 3 1/2"	3' 5 1/2"	3' 11 1/2"
(610) (597)	1-6/1-2	2-0/1-2	2-4/1-2	2-6/1-2	2-8/1-2	3-0/1-2	3-4/1-2	3-6/1-2	4-0/1-2
(457) (446)	1-6/1-6	2-0/1-6	2-4/1-6	2-6/1-6	2-8/1-6	3-0/1-6	3-4/1-6	3-6/1-6	4-0/1-6
(610) (597)	1-6/2-0	2-0/2-0	2-4/2-0	2-6/2-0	2-8/2-0	3-0/2-0	3-4/2-0	3-6/2-0	4-0/2-0

Vent Units

(762) (749)	1-6/2-6	2-0/2-6	2-4/2-6	2-6/2-6	2-8/2-6	3-0/2-6	3-4/2-6		
(914) (902)	1-6/3-0	2-0/3-0	2-4/3-0	2-6/3-0	2-8/3-0	3-0/3-0	3-4/3-0	3-6/3-0	4-0/3-0
(965) (953)	1-6/3-2	2-0/3-2	2-4/3-2	2-6/3-2	2-8/3-2	3-0/3-2	3-4/3-2	3-6/3-2	4-0/3-2
(1 067) (1 054)	1-6/3-6	2-0/3-6	2-4/3-6	2-6/3-6	2-8/3-6	3-0/3-6	3-4/3-6	3-6/3-6	4-0/3-6
(1 168) (1 156)	1-6/3-10	2-0/3-10	2-4/3-10	2-6/3-10	2-8/3-10	3-0/3-10	3-4/3-10	3-6/3-10	4-0/3-10
(1 219) (1 207)	1-6/4-0	2-0/4-0	2-4/4-0	2-6/4-0	2-8/4-0	3-0/4-0	3-4/4-0	3-6/4-0	4-0/4-0
(1 270) (1 257)	1-6/4-2	2-0/4-2	2-4/4-2	2-6/4-2	2-8/4-2	3-0/4-2	3-4/4-2	3-6/4-2	4-0/4-2
(1 372) (1 359)	1-6/4-6	2-0/4-6	2-4/4-6	2-6/4-6	2-8/4-6	3-0/4-6	3-4/4-6	3-6/4-6	4-0/4-6
(1 473) (1 461)	1-6/4-10	2-0/4-10	2-4/4-10	2-6/4-10	2-8/4-10	3-0/4-10	3-4/4-10	3-6/4-10	4-0/4-10

Egress Notes:

Check all applicable local codes for emergency egress requirements.

E = Window meets minimum clear opening of 24" height, 20" width, and 5.7 ft².

E1 = Window meets minimum clear opening of 24" height, 20" width, and 5.0 ft².

See Design Data pages in this section for clear opening dimensions.

Not to scale.

Special size units are available in 1/4" increments.

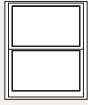

DOUBLE-HUNG

SIZE TABLES

Vent Units



Vent Units

	(457) (445)	(610) (597)	(711) (699)	(762) (749)	(813) (800)	(914) (902)	(1 016) (1 003)	(1 067) (1 054)	(1 219) (1 207)
Opening	1' 6"	2' 0"	2' 4"	2' 6"	2' 8"	3' 0"	3' 4"	3' 6"	4' 0"
Frame	1' 5 1/2"	1' 11 1/2"	2' 3 1/2"	2' 5 1/2"	2' 7 1/2"	2' 11 1/2"	3' 3 1/2"	3' 5 1/2"	3' 11 1/2"
(1 524) (1 511) 5' 0"	1-6/5-0	2-0/5-0	2-4/5-0	2-6/5-0	2-8/5-0	3-0/5-0 E ₁	3-4/5-0 E	3-6/5-0 E	4-0/5-0 E
(1 575) (1 562) 5' 2"	1-6/5-2	2-0/5-2	2-4/5-2	2-6/5-2	2-8/5-2 E ₁ (2)	3-0/5-2 E (1)	3-4/5-2 E	3-6/5-2 E	4-0/5-2 E
(1 676) (1 664) 5' 6"	1-6/5-6	2-0/5-6	2-4/5-6	2-6/5-6 E ₁ (2)	2-8/5-6 E ₁	3-0/5-6 E	3-4/5-6 E	3-6/5-6 E	4-0/5-6 E
(1 778) (1 765) 5' 10"	1-6/5-10	2-0/5-10	2-4/5-10 E ₁ (2)	2-6/5-10 E ₁	2-8/5-10 E (1)	3-0/5-10 E	3-4/5-10 E	3-6/5-10 E	4-0/5-10 E
(1 829) (1 816) 6' 0"	1-6/6-0	2-0/6-0	2-4/6-0 E ₁	2-6/6-0 E ₁	2-8/6-0 E	3-0/6-0 E	3-4/6-0 E	3-6/6-0 E	4-0/6-0 E
(1 981) (1 969) 6' 6"	1-6/6-6	2-0/6-6	2-4/6-6 E ₁	2-6/6-6 E	2-8/6-6 E	3-0/6-6 E	3-4/6-6 E	3-6/6-6 E	4-0/6-6 E

Egress Notes:

Check all applicable local codes for emergency egress requirements.

E = Window meets minimum clear opening of 24" height, 20" width, and 5.7 ft².

E₁ = Window meets minimum clear opening of 24" height, 20" width, and 5.0 ft².

(1) Unit meets E₁ with High Performance sill adapter kit installed.

(2) Does not meet egress with High Performance sill adapter kit installed.

See Design Data pages in this section for clear opening dimensions

Not to scale.

Special size units are available in 1/4" increments.

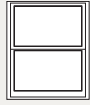

DOUBLE-HUNG

SIZE TABLES

Cottage Sash Units



Vent Cottage Units

	(457) (445)	(610) (597)	(711) (699)	(762) (749)	(813) (800)	(914) (902)	(1 067) (1 054)	(1 219) (1 207)
Opening	1' 6"	2' 0"	2' 4"	2' 6"	2' 8"	3' 0"	3' 6"	4' 0"
Frame	1' 5 1/2"	1' 11 1/2"	2' 3 1/2"	2' 5 1/2"	2' 7 1/2"	2' 11 1/2"	3' 5 1/2"	3' 11 1/2"
(1 372) (1 359)								
(1 524) (1 511)								
(1 676) (1 664)								
(1 829) (1 816)								
(1 981) (1 969)								

Egress Notes:

Check all applicable local codes for emergency egress requirements.

E = Window meets minimum clear opening of 24" height, 20" width, and 5.7 ft².

E1 = Window meets minimum clear opening of 24" height, 20" width, and 5.0 ft².

See Design Data pages in this section for clear opening dimensions

Cottage units have unequal sash. Sash glass ratio is 40% upper sash to 60% lower sash.
Special size units are available in 1/4" increments.

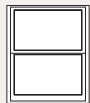

DOUBLE-HUNG

SIZE TABLES

Contemporary Units



Vent Contemporary Units

	(457) (445)	(610) (597)	(711) (699)	(762) (749)	(813) (800)	(914) (902)	(1 067) (1 054)	(1 219) (1 207)
Opening	1' 6"	2' 0"	2' 4"	2' 6"	2' 8"	3' 0"	3' 6"	4' 0"
Frame	1' 5 1/2"	1' 11 1/2"	2' 3 1/2"	2' 5 1/2"	2' 7 1/2"	2' 11 1/2"	3' 5 1/2"	3' 11 1/2"
(1 372) (1 359)								
(1 524) (1 511)								
(1 676) (1 664)								
(1 829) (1 816)								
(1 981) (1 969)								

Egress Notes:

Check all applicable local codes for emergency egress requirements.

E = Window meets minimum clear opening of 24" height, 20" width, and 5.7 ft².

E1 = Window meets minimum clear opening of 24" height, 20" width, and 5.0 ft².

See Design Data pages in this section for clear opening dimensions.

Contemporary units have unequal sash. Sash glass ratio is 60% upper sash to 40% lower sash.
Special size units are available in 1/4" increments.

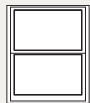

DOUBLE-HUNG

SIZE TABLES

Fixed Units



Fixed Transoms

	(356) (343)	(914) (902)	(1 067) (1 054)	(1 219) (1 207)	(1 372) (1 359)	(1 524) (1 511)	(1 829) (1 816)
Opening	1' 2"	3' 0"	3' 6"	4' 0"	4' 6"	5' 0"	6' 0"
Frame	1' 1 1/2"	2' 11 1/2"	3' 5 1/2"	3' 11 1/2"	4' 5 1/2"	4' 11 1/2"	5' 11 1/2"
(356) (343)							
(457) (446)							
(610) (597)							

Fixed Units

	(762) (749)	(914) (902)	(1 067) (1 054)	(1 219) (1 207)	(1 372) (1 359)	(1 524) (1 511)	(1 829) (1 816)
Opening	2' 6"	3' 0"	3' 6"	4' 0"	4' 6"	5' 0"	6' 0"
Frame	2' 5 1/2"	2' 11 1/2"	3' 5 1/2"	3' 11 1/2"	4' 5 1/2"	4' 11 1/2"	5' 11 1/2"
(762) (749)							
(914) (902)							
(1 067) (1 054)							
(1 219) (1 207)							
(1 372) (1 359)							
(1 524) (1 511)							
(1 676) (1 664)							
(1 829) (1 816)							

Not to scale.

Special size units are available in 1/4" increments.

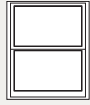

DOUBLE-HUNG

DESIGN DATA

Vent Units



VENT UNITS

Unit	Egress	Clear Opening ³ (Inches)		Vent Area Ft ²	Visible Glass Ft ²	Standard Glass Thickness (mm)		Performance Class & Grade ⁴	
		Width	Height			Annealed	Tempered	Standard	Upgrade
1-6/2-6		13-3/8	11	1.0	1.6	2.5	3	LC30	LC50
1-6/3-0		13-3/8	14	1.3	2.1	2.5	3	LC30	LC50
1-6/3-2		13-3/8	15	1.4	2.2	2.5	3	LC30	LC50
1-6/3-6		13-3/8	17	1.6	2.5	2.5	3	LC30	LC50
1-6/3-10		13-3/8	19	1.8	2.9	2.5	3	LC30	LC50
1-6/4-0		13-3/8	20	1.9	3.0	2.5	3	LC30	LC50
1-6/4-2		13-3/8	21	2.0	3.2	2.5	3	LC30	LC50
1-6/4-6		13-3/8	23	2.1	3.5	2.5	3	LC30	LC50
1-6/4-10		13-3/8	26	2.3	3.8	2.5	3	LC30	LC50
1-6/5-0		13-3/8	26	2.4	3.9	2.5	3	LC30	LC50
1-6/5-2		13-3/8	27	2.5	4.1	2.5	3	LC30	LC50
1-6/5-6		13-3/8	29	2.7	4.4	2.5	3	LC30	LC50
1-6/5-10		13-3/8	31	2.9	4.7	2.5	3	LC30	LC50
1-6/6-0		13-3/8	32	3.0	4.8	2.5	3	LC30	LC50
1-6/6-6		13-3/8	35	3.3	5.3	2.5	3	LC30	–
2-0/2-6		19-3/8	11	1.5	2.5	2.5	3	LC30	LC50
2-0/3-0		19-3/8	14	1.9	3.2	2.5	3	LC30	LC50
2-0/3-2		19-3/8	15	2.0	3.5	2.5	3	LC30	LC50
2-0/3-6		19-3/8	17	2.3	3.9	2.5	3	LC30	LC50
2-0/3-10		19-3/8	19	2.6	4.4	2.5	3	LC30	LC50
2-0/4-0		19-3/8	20	2.7	4.6	2.5	3	LC30	LC50
2-0/4-2		19-3/8	21	2.8	4.9	2.5	3	LC30	LC50
2-0/4-6		19-3/8	23	3.1	5.3	2.5	3	LC30	LC50
2-0/4-10		19-3/8	25	3.4	5.8	2.5	3	LC30	LC50
2-0/5-0		19-3/8	26	3.5	6.1	2.5	3	LC30	LC50
2-0/5-2		19-3/8	27	3.6	6.3	2.5	3	LC30	LC50
2-0/5-6		19-3/8	29	3.9	6.8	2.5	3	LC30	LC50
2-0/5-10		19-3/8	31	4.2	7.2	2.5	3	LC30	LC50
2-0/6-0		19-3/8	32	4.3	7.5	2.5	3	LC30	LC50
2-0/6-6		19-3/8	35	4.7	8.2	2.5	3	LC30	–
2-4/2-6		23-3/8	11	1.8	3.1	2.5	3	LC30	LC50
2-4/3-0		23-3/8	14	2.3	4.0	2.5	3	LC30	LC50
2-4/3-2		23-3/8	15	2.4	4.3	2.5	3	LC30	LC50
2-4/3-6		23-3/8	17	2.8	4.8	2.5	3	LC30	LC50
2-4/3-10		23-3/8	19	3.1	5.4	2.5	3	LC30	LC50
2-4/4-0		23-3/8	20	3.2	5.7	2.5	3	LC30	LC50
2-4/4-2		23-3/8	21	3.4	6.0	2.5	3	LC30	LC50
2-4/4-6		23-3/8	23	3.7	6.6	2.5	3	LC30	LC50
2-4/4-10		23-3/8	25	4.1	7.2	2.5	3	LC30	LC50
2-4/5-0		23-3/8	26	4.2	7.5	2.5	3	LC30	LC50
2-4/5-2		23-3/8	27	4.4	7.8	2.5	3	LC30	LC50
2-4/5-6		23-3/8	29	4.7	8.4	2.5	3	LC30	LC50
2-4/5-10	E1 ⁽²⁾	23-3/8	31	5.0	8.9	2.5	3	LC30	LC50
2-4/6-0	E1	23-3/8	32	5.2	9.2	2.5	3	LC30	LC50
2-4/6-6	E1	23-3/8	35	5.7	10.1	2.5	3	LC30	–

Egress Notes:

Check all applicable local codes for emergency egress requirements.

E = Window meets minimum clear opening of 24" height, 20" width, and 5.7 ft².

E1 = Window meets minimum clear opening of 24" height, 20" width, and 5.0 ft².

(1) Unit meets E1 with High Performance sill adapter kit installed.

(2) Does not meet egress with High Performance sill adapter kit installed. To convert areas to square meters (m²), multiply square feet (ft²) by 0.0929.

(3) Subtract one Inch from opening height to calculate vent area for performance upgrade units.

(4) The upgrade value, where shown, is maximum performance with upgrade kit installed. Both values are based on maximum performance when glazed with the appropriate glass thickness.

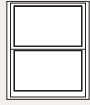

DOUBLE-HUNG

DESIGN DATA

Vent Units (Continued)



VENT UNITS

Unit	Egress	Clear Opening ³ (Inches)		Vent Area Ft ²	Visible Glass Ft ²	Standard Glass Thickness (mm)		Performance Class & Grade ⁴	
		Width	Height			Annealed	Tempered	Standard	Upgrade
2-6/2-6		25-3/8	10	1.9	3.4	2.5	3	LC30	LC50
2-6/3-0		25-3/8	14	2.5	4.3	2.5	3	LC30	LC50
2-6/3-2		25-3/8	15	2.6	4.7	2.5	3	LC30	LC50
2-6/3-6		25-3/8	17	3.0	5.3	2.5	3	LC30	LC50
2-6/3-10		25-3/8	19	3.3	5.9	2.5	3	LC30	LC50
2-6/4-0		25-3/8	20	3.5	6.3	2.5	3	LC30	LC50
2-6/4-2		25-3/8	21	3.7	6.6	2.5	3	LC30	LC50
2-6/4-6		25-3/8	23	4.1	7.2	2.5	3	LC30	LC50
2-6/4-10		25-3/8	25	4.4	7.9	2.5	3	LC30	LC50
2-6/5-0		25-3/8	26	4.6	8.2	2.5	3	LC30	LC50
2-6/5-2		25-3/8	27	4.8	8.5	2.5	3	LC30	LC50
2-6/5-6	E1(2)	25-3/8	29	5.1	9.1	2.5	3	LC30	LC50
2-6/5-10	E1	25-3/8	31	5.5	9.8	2.5	3	LC30	LC50
2-6/6-0	E1	25-3/8	32	5.6	10.1	2.5	3	LC30	LC50
2-6/6-6	E	25-3/8	35	6.2	11.1	2.5	3	LC30	-
2-8/2-6		27-3/8	11	2.1	3.7	2.5	3	LC30	LC50
2-8/3-0		27-3/8	14	2.7	4.7	2.5	3	LC30	LC50
2-8/3-2		27-3/8	15	2.9	5.1	2.5	3	LC30	LC50
2-8/3-6		27-3/8	17	3.2	5.8	2.5	3	LC30	LC50
2-8/3-10		27-3/8	19	3.6	6.5	2.5	3	LC30	LC50
2-8/4-0		27-3/8	20	3.8	6.8	2.5	3	LC30	LC50
2-8/4-2		27-3/8	21	4.0	7.2	2.5	3	LC30	LC50
2-8/4-6		27-3/8	23	4.4	7.9	2.5	3	LC30	LC50
2-8/4-10		27-3/8	25	4.8	8.5	2.5	3	LC30	LC50
2-8/5-0		27-3/8	26	4.9	8.9	2.5	3	LC30	LC50
2-8/5-2	E1(2)	27-3/8	27	5.1	9.2	2.5	3	LC30	LC50
2-8/5-6	E1	27-3/8	29	5.5	9.9	2.5	3	LC30	LC50
2-8/5-10	E(1)	27-3/8	31	5.9	10.6	2.5	3	LC30	LC50
2-8/6-0	E	27-3/8	32	6.1	11.0	2.5	3	LC30	LC50
2-8/6-6	E	27-3/8	35	6.7	12.0	2.5	3	LC30	-
3-0/2-6		31-3/8	11	2.4	4.3	2.5	3	LC30	LC50
3-0/3-0		31-3/8	14	3.1	5.5	2.5	3	LC30	LC50
3-0/3-2		31-3/8	15	3.3	5.9	2.5	3	LC30	LC50
3-0/3-6		31-3/8	17	3.7	6.7	2.5	3	LC30	LC50
3-0/3-10		31-3/8	19	4.1	7.5	2.5	3	LC30	LC50
3-0/4-0		31-3/8	20	4.4	7.9	2.5	3	LC30	LC50
3-0/4-2		31-3/8	21	4.6	8.3	2.5	3	LC30	LC50
3-0/4-6		31-3/8	23	5.0	9.1	2.5	3	LC30	LC50
3-0/4-10	E1	31-3/8	25	5.4	9.9	2.5	3	LC30	LC50
3-0/5-0	E1	31-3/8	26	5.7	10.3	2.5	3	LC30	LC50
3-0/5-2	E(1)	31-3/8	27	5.9	10.7	2.5	3	LC30	LC50
3-0/5-6	E	31-3/8	29	6.3	11.5	2.5	3	LC30	LC50
3-0/5-10	E	31-3/8	31	6.8	12.3	2.5	3	LC30	LC50
3-0/6-0	E	31-3/8	32	7.0	12.7	2.5	3	LC30	LC50
3-0/6-6	E	31-3/8	35	7.6	14.0	2.5	3	LC30	-

Egress Notes:

Check all applicable local codes for emergency egress requirements.

E = Window meets minimum clear opening of 24" height, 20" width, and 5.7 ft².

E1 = Window meets minimum clear opening of 24" height, 20" width, and 5.0 ft².

(1) Unit meets E1 with High Performance sill adapter kit installed.
 (2) Does not meet egress with High Performance sill adapter kit installed.
 To convert areas to square meters (m²), multiply square feet (ft²) by 0.0929.

(3) Subtract one Inch from opening height to calculate vent area for performance upgrade units.

(4) The upgrade value, where shown, is maximum performance with upgrade kit installed. Both values are based on maximum performance when glazed with the appropriate glass thickness.

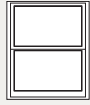

DOUBLE-HUNG

DESIGN DATA

Vent Units (Continued)



VENT UNITS									
Unit	Egress	Clear Opening ³ (Inches)		Vent Area Ft ²	Visible Glass Ft ²	Standard Glass Thickness (mm)		Performance Class & Grade ⁴	
		Width	Height			Annealed	Tempered	Standard	Upgrade
3-4/2-6		35-3/8	8	2.7	4.9	2.5	3	LC30	LC50
3-4/3-0		35-3/8	14	3.4	6.2	2.5	3	LC30	LC50
3-4/3-2		35-3/8	15	3.7	6.7	2.5	3	LC30	LC50
3-4/3-6		35-3/8	17	4.2	7.6	2.5	3	LC30	LC50
3-4/3-10		35-3/8	19	4.7	8.5	2.5	3	LC30	LC50
3-4/4-0		35-3/8	20	4.9	9.0	2.5	3	LC30	LC50
3-4/4-2		35-3/8	21	5.2	9.4	2.5	3	LC30	LC50
3-4/4-6		35-3/8	23	5.7	10.4	2.5	3	LC30	LC50
3-4/4-10	E	35-3/8	25	6.1	11.3	2.5	3	LC30	LC50
3-4/5-0	E	35-3/8	26	6.4	11.7	2.5	3	LC30	LC50
3-4/5-2	E	35-3/8	27	6.6	12.2	2.5	3	LC30	LC50
3-4/5-6	E	35-3/8	29	7.1	13.1	2.5	3	LC30	LC50
3-4/5-10	E	35-3/8	31	7.6	14.0	2.5	3	LC30	–
3-4/6-0	E	35-3/8	32	7.9	14.5	2.5	3	LC30	–
3-4/6-6	E	35-3/8	35	8.6	15.9	2.5	3	LC30	–
3-6/3-0		37-3/8	14	3.6	6.6	2.5	3	LC30	LC50
3-6/3-2		37-3/8	15	3.9	7.1	2.5	3	LC30	LC50
3-6/3-6		37-3/8	17	4.4	8.1	2.5	3	LC30	LC50
3-6/3-10		37-3/8	19	4.9	9.0	2.5	3	LC30	LC50
3-6/4-0		37-3/8	20	5.2	9.5	2.5	3	LC30	LC50
3-6/4-2		37-3/8	21	5.5	10.0	2.5	3	LC30	LC50
3-6/4-6		37-3/8	23	6.0	11.0	2.5	3	LC30	LC50
3-6/4-10	E	37-3/8	25	6.5	12.0	2.5	3	LC30	LC50
3-6/5-0	E	37-3/8	26	6.7	12.4	2.5	3	LC30	LC50
3-6/5-2	E	37-3/8	27	7.0	12.9	2.5	3	LC30	LC50
3-6/5-6	E	37-3/8	29	7.5	13.9	2.5	3	LC30	LC50
3-6/5-10	E	37-3/8	31	8.0	14.9	2.5	3	LC30	–
3-6/6-0	E	37-3/8	32	8.3	15.4	2.5	3	LC30	–
3-6/6-6	E	37-3/8	35	9.1	16.8	2.5	3	LC30	–
4-0/3-0		43-3/8	14	4.2	7.7	2.5	3	LC30	LC50
4-0/3-2		43-3/8	15	4.5	8.3	2.5	3	LC30	LC50
4-0/3-6		43-3/8	17	5.1	9.4	2.5	3	LC30	LC50
4-0/3-10		43-3/8	19	5.7	10.6	2.5	3	LC30	LC50
4-0/4-0		43-3/8	20	6.0	11.2	2.5	3	LC30	LC50
4-0/4-2		43-3/8	21	6.3	11.7	2.5	3	LC30	LC50
4-0/4-6		43-3/8	23	6.9	12.9	2.5	3	LC30	LC50
4-0/4-10	E	43-3/8	25	7.5	14.0	2.5	3	LC30	–
4-0/5-0	E	43-3/8	26	7.8	14.6	2.5	3	LC30	–
4-0/5-2	E	43-3/8	27	8.1	15.1	2.5	3	LC30	–
4-0/5-6	E	43-3/8	29	8.7	16.3	2.5	3	LC30	–
4-0/5-10	E	43-3/8	31	9.3	17.4	2.5	3	LC30	–
4-0/6-0	E	43-3/8	32	9.6	18.0	2.5	3	LC30	–
4-0/6-6	E	43-3/8	35	10.5	19.7	2.5	3	LC30	–

Egress Notes:
 Check all applicable local codes for emergency egress requirements.
 E = Window meets minimum clear opening of 24" height, 20" width, and 5.7 ft².
 To convert areas to square meters (m²), multiply square feet (ft²) by 0.0929.

Clear Opening Formulas

EQUAL VENT	WIDTH	HEIGHT ₁
	FW - 4-1/8"	FH/2 - 3-3/4"

KEY:
 FW = Frame Width
 FH = Frame Height

Miscellaneous Glass Formulas

EQUAL VENT	ACTUAL GLASS WIDTH	ACTUAL GLASS HEIGHT (LOWER SASH)	ACTUAL GLASS HEIGHT (UPPER SASH)	VISIBLE GLASS WIDTH	VISIBLE GLASS HEIGHT (LOWER SASH)	VISIBLE GLASS HEIGHT (UPPER SASH)
	(AGW)	(ALGH)	(AUGH)	(VGW)	(VLGH)	(VUGH)
	FW - 5-1/2"	FH/2 - 3-1/4"	FH/2 - 3-1/4"	FW - 6.438"	FH/2 - 4.188"	FH/2 - 4.188"

(3) Subtract one Inch from opening height to calculate vent area for performance upgrade units.

(4) The upgrade value, where shown, is maximum performance with upgrade kit installed. Both values are based on maximum performance when glazed with the appropriate glass thickness.

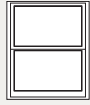

DOUBLE-HUNG

DESIGN DATA

Cottage Sash



COTTAGE SASH

Unit	Egress	Clear Opening ₁ (Inches)		Vent Area Ft ²	Visible Glass Ft ²	Standard Glass Thickness (mm)		Performance Class & Grade ₂	
		Width	Height			Annealed	Tempered	Standard	Upgrade
1-6/4-6		13-3/8	18-3/16	1.7	3.5	2.5	3	LC30	LC50
1-6/5-0		13-3/8	20-11/16	1.9	3.9	2.5	3	LC30	LC50
1-6/5-6		13-3/8	23-1/8	2.1	4.4	2.5	3	LC30	LC50
1-6/6-0		13-3/8	25-1/2	2.3	4.8	2.5	3	LC30	LC50
1-6/6-6		13-3/8	27-7/8	2.5	5.3	2.5	3	LC30	–
2-0/4-6		19-3/8	18-3/16	2.4	5.3	2.5	3	LC30	LC50
2-0/5-0		19-3/8	20-11/16	2.7	6.1	2.5	3	LC30	LC50
2-0/5-6		19-3/8	23-1/8	3.1	6.8	2.5	3	LC30	LC50
2-0/6-0		19-3/8	25-1/2	3.4	7.5	2.5	3	LC30	LC50
2-0/6-6		19-3/8	27-7/8	3.7	8.2	2.5	3	LC30	–
2-4/4-6		23-3/8	18-3/16	2.9	6.6	2.5	3	LC30	LC50
2-4/5-0		23-3/8	20-11/16	3.3	7.5	2.5	3	LC30	LC50
2-4/5-6		23-3/8	23-1/8	3.7	8.4	2.5	3	LC30	LC50
2-4/6-0		23-3/8	25-1/2	4.1	9.2	2.5	3	LC30	LC50
2-4/6-6		23-3/8	27-7/8	4.5	10.1	2.5	3	LC30	–
2-6/4-6		25-3/8	18-3/16	3.2	7.2	2.5	3	LC30	LC50
2-6/5-0		25-3/8	20-11/16	3.6	8.2	2.5	3	LC30	LC50
2-6/5-6		25-3/8	23-1/8	4.1	9.1	2.5	3	LC30	LC50
2-6/6-0		25-3/8	25-1/2	4.5	10.1	2.5	3	LC30	LC50
2-6/6-6		25-3/8	27-7/8	4.9	11.1	2.5	3	LC30	–
2-8/4-6		27-3/8	18-3/16	3.4	7.9	2.5	3	LC30	LC50
2-8/5-0		27-3/8	20-11/16	3.9	8.9	2.5	3	LC30	LC50
2-8/5-6		27-3/8	23-1/8	4.3	9.9	2.5	3	LC30	LC50
2-8/6-0		27-3/8	25-1/2	4.8	11.0	2.5	3	LC30	LC50
2-8/6-6	E1	27-3/8	27-7/8	5.3	12.0	2.5	3	LC30	–
3-0/4-6		31-3/8	18-3/16	3.9	9.1	2.5	3	LC30	LC50
3-0/5-0		31-3/8	20-11/16	4.5	10.3	2.5	3	LC30	LC50
3-0/5-6		31-3/8	23-1/8	5.0	11.5	2.5	3	LC30	LC50
3-0/6-0	E1	31-3/8	25-1/2	5.5	12.7	2.5	3	LC30	LC50
3-0/6-6	E	31-3/8	27-7/8	6.0	14.0	2.5	3	LC30	–
3-6/4-6		37-3/8	18-3/16	4.7	11.0	2.5	3	LC30	LC50
3-6/5-0		37-3/8	20-11/16	5.3	12.4	2.5	3	LC30	LC50
3-6/5-6		37-3/8	23-1/8	5.9	13.9	2.5	3	LC30	LC50
3-6/6-0	E	37-3/8	25-1/2	6.6	15.4	2.5	3	LC30	–
3-6/6-6	E	37-3/8	27-7/8	7.2	16.8	2.5	3	LC30	–
4-0/4-6		43-3/8	18-3/16	5.5	12.9	2.5	3	LC30	LC50
4-0/5-0		43-3/8	20-11/16	6.2	14.6	2.5	3	LC30	–
4-0/5-6		43-3/8	23-1/8	6.9	16.6	2.5	3	LC30	–
4-0/6-0	E	43-3/8	25-1/2	7.6	18.0	3	3	LC30	–
4-0/6-6	E	43-3/8	27-7/8	8.4	19.7	3	3	LC30	–

Egress Notes:

Check all applicable local codes for emergency egress requirements.

E = Window meets minimum clear opening of 24" height, 20" width, and 5.7 ft².

E1 = Window meets minimum clear opening of 24" height, 20" width, and 5.0 ft².

To convert areas to square meters (m²), multiply square feet (ft²) by 0.0929.

Clear Opening Formulas

	WIDTH	HEIGHT ₁
EQUAL VENT	FW - 4-1/8"	(FH - ALGH) - 7"

KEY:

FW = Frame Width

FH = Frame Height

Miscellaneous Glass Formulas For Cottage Vent Units

ACTUAL GLASS WIDTH	ACTUAL GLASS HEIGHT (LOWER SASH)	ACTUAL GLASS HEIGHT (UPPER SASH)	VISIBLE GLASS WIDTH	VISIBLE GLASS HEIGHT (LOWER SASH)	VISIBLE GLASS HEIGHT (UPPER SASH)
(AGW)	(ALGH)	(AUGH)	(VGW)	(VLGH)	(VUGH)
FW - 5-1/2"	(FH - 6-1/2") x 0.6	(FH - 6-1/2") x 0.4	FW - 6-7/16"	(FH - 6-1/2") x 0.6 - 0.938	(FH - 6-1/2") x 0.4 - 0.938

(1) Subtract one Inch from opening height to calculate vent area for performance upgrade units.

(2) The upgrade value, where shown, is maximum performance with upgrade kit installed. Both values are based on maximum performance when glazed with the appropriate glass thickness.

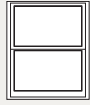

DOUBLE-HUNG

DESIGN DATA

Contemporary Sash



CONTEMPORARY SASH

Unit	Egress	Clear Opening ₁ (Inches)		Vent Area Ft ²	Visible Glass Ft ²	Standard Glass Thickness (mm)		Performance Class & Grade ₂	
		Width	Height			Annealed	Tempered	Standard	Upgrade
1-6/4-6		13-3/8	18-3/16	1.7	3.5	2.5	3	LC30	LC50
1-6/5-0		13-3/8	20-11/16	1.9	3.9	2.5	3	LC30	LC50
1-6/5-6		13-3/8	23-1/8	2.1	4.4	2.5	3	LC30	LC50
1-6/6-0		13-3/8	25-1/2	2.3	4.8	2.5	3	LC30	LC50
1-6/6-6		13-3/8	27-7/8	2.5	5.3	2.5	3	LC30	–
2-0/4-6		19-3/8	18-3/16	2.4	5.3	2.5	3	LC30	LC50
2-0/5-0		19-3/8	20-11/16	2.7	6.1	2.5	3	LC30	LC50
2-0/5-6		19-3/8	23-1/8	3.1	6.8	2.5	3	LC30	LC50
2-0/6-0		19-3/8	25-1/2	3.4	7.5	2.5	3	LC30	LC50
2-0/6-6		19-3/8	27-7/8	3.7	8.2	2.5	3	LC30	–
2-4/4-6		23-3/8	18-3/16	2.9	6.6	2.5	3	LC30	LC50
2-4/5-0		23-3/8	20-11/16	3.3	7.5	2.5	3	LC30	LC50
2-4/5-6		23-3/8	23-1/8	3.7	8.4	2.5	3	LC30	LC50
2-4/6-0		23-3/8	25-1/2	4.1	9.2	2.5	3	LC30	LC50
2-4/6-6		23-3/8	27-7/8	4.5	10.1	2.5	3	LC30	–
2-6/4-6		25-3/8	18-3/16	3.2	7.2	2.5	3	LC30	LC50
2-6/5-0		25-3/8	20-11/16	3.6	8.2	2.5	3	LC30	LC50
2-6/5-6		25-3/8	23-1/8	4.1	9.1	2.5	3	LC30	LC50
2-6/6-0		25-3/8	25-1/2	4.5	10.1	2.5	3	LC30	LC50
2-6/6-6		25-3/8	27-7/8	4.9	11.1	2.5	3	LC30	–
2-8/4-6		27-3/8	18-3/16	3.4	7.9	2.5	3	LC30	LC50
2-8/5-0		27-3/8	20-11/16	3.9	8.9	2.5	3	LC30	LC50
2-8/5-6		27-3/8	23-1/8	4.3	9.9	2.5	3	LC30	LC50
2-8/6-0		27-3/8	25-1/2	4.8	11.0	2.5	3	LC30	LC50
2-8/6-6	E1	27-3/8	27-7/8	5.3	12.0	2.5	3	LC30	–
3-0/4-6		31-3/8	18-3/16	3.9	9.1	2.5	3	LC30	LC50
3-0/5-0		31-3/8	20-11/16	4.5	10.3	2.5	3	LC30	LC50
3-0/5-6		31-3/8	23-1/8	5.0	11.5	2.5	3	LC30	LC50
3-0/6-0	E1	31-3/8	25-1/2	5.5	12.7	2.5	3	LC30	LC50
3-0/6-6	E	31-3/8	27-7/8	6.0	14.0	2.5	3	LC30	–
3-6/4-6		37-3/8	18-3/16	4.7	11.0	2.5	3	LC30	LC50
3-6/5-0		37-3/8	20-11/16	5.3	12.4	2.5	3	LC30	LC50
3-6/5-6		37-3/8	23-1/8	5.9	13.9	2.5	3	LC30	LC50
3-6/6-0	E	37-3/8	25-1/2	6.6	15.4	2.5	3	LC30	–
3-6/6-6	E	37-3/8	27-7/8	7.2	16.8	2.5	3	LC30	–
4-0/4-6		43-3/8	18-3/16	5.5	12.9	2.5	3	LC30	LC50
4-0/5-0		43-3/8	20-11/16	6.2	14.6	2.5	3	LC30	–
4-0/5-6		43-3/8	23-1/8	6.9	16.6	2.5	3	LC30	–
4-0/6-0	E	43-3/8	25-1/2	7.6	18.0	3	3	LC30	–
4-0/6-6	E	43-3/8	27-7/8	8.4	19.7	3	3	LC30	–

Egress Notes:

Check all applicable local codes for emergency egress requirements.

E = Window meets minimum clear opening of 24" height, 20" width, and 5.7 ft².

E1 = Window meets minimum clear opening of 24" height, 20" width, and 5.0 ft².

To convert areas to square meters (m²), multiply square feet (ft²) by 0.0929.

Clear Opening Formulas

EQUAL VENT	WIDTH	HEIGHT ₁
	FW - 4-1/8"	(FH - AUGH) - 7"

KEY:

FW = Frame Width

FH = Frame Height

Miscellaneous Glass Formulas For Contemporary Vent Units

ACTUAL GLASS WIDTH	ACTUAL GLASS HEIGHT (LOWER SASH)	ACTUAL GLASS HEIGHT (UPPER SASH)	VISIBLE GLASS WIDTH	VISIBLE GLASS HEIGHT (LOWER SASH)	VISIBLE GLASS HEIGHT (UPPER SASH)
(AGW)	(ALGH)	(AUGH)	(VGW)	(VLGH)	(VUGH)
FW - 5-1/2"	(FH - 6-1/2") x 0.4	(FH - 6-1/2") x 0.6	FW - 6-7/16"	(FH - 6-1/2") x 0.4 - 0.938	(FH - 6-1/2") x 0.6 - 0.938

(1) Subtract one Inch from opening height to calculate vent area for performance upgrade units.

(2) The upgrade value, where shown, is maximum performance with upgrade kit installed. Both values are based on maximum performance when glazed with the appropriate glass thickness.

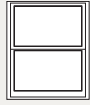

DOUBLE-HUNG

DESIGN DATA

Fixed Units



FIXED UNITS

Unit	Visible Glass Ft ²	Standard Glass Thickness (mm)		Performance Class & Grade ₁
		Annealed	Tempered	
3-0/2-6	4.8	2.5	3	CW50
3-0/3-0	6.0	2.5	3	CW50
3-0/3-6	7.2	2.5	3	CW50
3-0/4-0	8.5	2.5	3	CW50
3-0/4-6	9.7	2.5	3	CW50
3-0/5-0	10.9	3	3	CW50
3-0/5-6	12.2	3	3	CW50
3-0/6-0	13.4	3	3	CW50
3-6/2-6	5.8	2.5	3	CW50
3-6/3-0	7.2	2.5	3	CW50
3-6/3-6	8.7	2.5	3	CW50
3-6/4-0	10.2	3	3	CW50
3-6/4-6	11.7	3	3	CW50
3-6/5-0	13.2	3	3	CW50
3-6/5-6	14.6	3	3	CW50
3-6/6-0	16.1	3	3	CW50
4-0/2-6	6.7	2.5	3	CW50
4-0/3-0	8.5	2.5	3	CW50
4-0/3-6	10.2	3	3	CW50
4-0/4-0	11.9	3	3	CW50
4-0/4-6	13.7	3	3	CW50
4-0/5-0	15.4	3	3	CW50
4-0/5-6	17.1	3	3	CW50
4-0/6-0	18.8	5	5	CW50
4-6/2-6	7.7	2.5	3	CW50
4-6/3-0	9.7	2.5	3	CW50
4-6/3-6	11.7	3	3	CW50
4-6/4-0	13.7	3	3	CW50
4-6/4-6	15.6	3	3	CW50
4-6/5-0	17.6	5	5	CW50
4-6/5-6	19.6	5	5	CW50
4-6/6-0	21.6	5	5	CW50
5-0/2-6	8.7	2.5	3	CW50
5-0/3-0	10.9	3	3	CW50
5-0/3-6	13.2	3	3	CW50
5-0/4-0	15.4	3	3	CW50
5-0/4-6	17.6	5	5	CW50
5-0/5-0	19.8	5	5	CW50
5-0/5-6	22.1	5	5	CW50
5-0/6-0	24.3	5	5	CW50
6-0/2-6	10.7	3	3	CW50
6-0/3-0	13.4	3	3	CW50
6-0/3-6	16.1	3	3	CW50
6-0/4-0	18.8	5	5	CW50
6-0/4-6	21.6	5	5	CW50
6-0/5-0	24.3	5	5	CW50
6-0/5-6	27.0	5	5	CW50
6-0/6-0	29.7	5	5	CW50

FIXED UNITS

Unit	Visible Glass Ft ²	Standard Glass Thickness (mm)		Performance Class & Grade ₁
		Annealed	Tempered	
FLANKERS				
1-2/3-0	1.5	2.5	3	CW50
1-2/3-6	1.8	2.5	3	CW50
1-2/4-0	2.1	3	3	CW50
1-2/4-6	2.5	3	3	CW50
1-2/5-0	2.8	3	3	CW50
TRANSOM UNITS				
2-6/1-2	1.2	2.5	3	CW50
2-6/1-6	1.9	2.5	3	CW50
2-6/2-0	2.5	2.5	3	CW50
3-0/1-2	1.5	2.5	3	CW50
3-0/1-6	2.3	2.5	3	CW50
3-0/2-0	3.2	2.5	3	CW50
3-6/1-2	1.8	2.5	3	CW50
3-6/1-6	2.8	2.5	3	CW50
3-6/2-0	3.8	2.5	3	CW50
4-0/1-2	2.1	3	3	CW50
4-0/1-6	3.3	2.5	3	CW50
4-0/2-0	4.4	2.5	3	CW50
4-6/1-2	2.5	3	3	CW50
4-6/1-6	3.8	2.5	3	CW50
4-6/2-0	5.1	2.5	3	CW50
5-0/1-2	2.8	3	3	CW50
5-0/1-6	4.2	2.5	3	CW50
5-0/2-0	5.7	2.5	3	CW50
6-0/1-2	3.4	3	3	CW50
6-0/1-6	5.2	3	3	CW50
6-0/2-0	7.0	2.5	3	CW50

Miscellaneous Formulas

	ACTUAL GLASS WIDTH	ACTUAL GLASS HEIGHT	VISIBLE GLASS WIDTH	VISIBLE GLASS HEIGHT
	(AGW)	(AGH)	(VGW)	(VGH)
FIXED	FW - 5-1/8"	FH - 5-1/8"	FW - 6-1/16"	FH - 6-1/16"

KEY:

FW = Frame Width

FH = Frame Height

(1) Maximum performance when glazed with the appropriate glass thickness.
To convert areas to square meters (m²), multiply square feet by 0.0929.

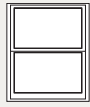

DOUBLE-HUNG

DETAILED PRODUCT DESCRIPTIONS



FRAME

- Frame is Duracast® fiberglass composite – five-layer pultruded fiberglass material [with optional foam insulation₁] reinforced with a Pella patented interlocking mat.
- Nominal wall thickness of Duracast fiberglass composite members is .050" to .080" thick.
- [Overall frame depth is 3" for [Block Frame] [Integral Nailing Fin] [Overall frame depth is 3-1/4" for Precision Fit].
- Frame corners are mitered, joined and bonded with corner locks and mechanically fastened with injected polyurethane adhesive.
- Block frame jambs contain factory drilled (counter-bored) installation screw holes.
- Frame has 10° slope sill.

SASH

- Sash is Duracast fiberglass composite–five-layer pultruded fiberglass material [with optional foam insulation₁] reinforced with a Pella patented interlocking mat.
- All sash members have mitered corners bonded with corner locks and sealed with injected polyurethane adhesive.
- Both sashes tilt to interior for cleaning.

EXTERIOR / INTERIOR

- Duracast fiberglass composite surfaces with powder-coat paint finish.
 - Color is [White] [Tan] [Brown] [Black] [Morning Sky Gray].
 - or –
 - Dual-color option [Tan] [Brown] [Black] [Morning Sky Gray] exterior with White interior₂.

GLAZING SYSTEM

- Quality float glass complying with ASTM C 1036.
- 11/16" insulating glass [[annealed] [tempered]] [obscure₃] [[clear] [Advanced] [SunDefense™] [AdvancedComfort] [NaturalSun] Low-E coated, with argon]] sealed and bonded to sash.
- High altitude glazing [with argon] available.

WEATHERSTRIPPING

- Fin-type pile on jambs, top rail and stile of upper sash.
- Vinyl-wrapped foam at sill on frame and bottom rail of lower sash.

FOAM INSULATION INSERTS ₁

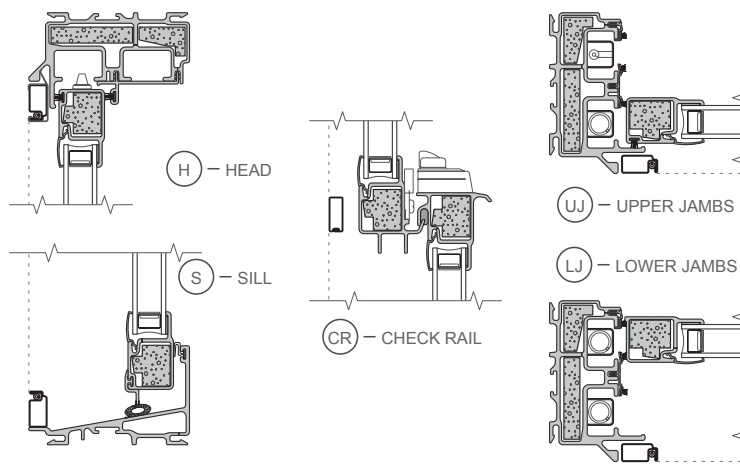

HARDWARE

- Galvanized block-and-tackle balances connected to sash with polyester cord and concealed within the frame.
- Upper and lower sash are fully operable for ventilation.
- All fasteners are corrosion-resistant material.
- Two locks are installed on units 37" wide or greater.
- Locks are zinc die-cast, self-aligning cam action factory-installed on the interlocker [powder-coat painted [White] [Tan] [Brown] [Black] [Morning Sky Gray] to match finish] [Satin Nickel] [Bright Brass] [Oil-Rubbed Bronze].

OPTIONAL PRODUCTS

Screens

- Conventional Black Fiberglass
 - [Half-size] [Full-size] with black vinyl coated 18/16 mesh fiberglass screen cloth complying with ASTM D 3656 and SMA 1201.
 - Set in aluminum frame and fitted to outside of window.
 - Supplied complete with all necessary hardware.
 - Screen frame finish is baked enamel, color to match exterior.
- InView™ Screens
 - [Half-size] [Full-size] with black vinyl coated 18/18 mesh fiberglass screen cloth complying with SMA 1201.
 - Set in aluminum frame and fitted to outside of window.
 - Supplied complete with all necessary hardware.
 - Screen frame finish is baked enamel, color to match exterior.

Grilles

- Grilles-Between-the-Glass
 - Insulating glass contains 3/4" contoured aluminum grilles permanently installed between two panes of glass.
 - Grilles are factory prefinished [White] [Tan] [Brown] [Black] [Morning Sky Gray] to match interior and exterior finish.

Hardware

- Optional limited opening device available for vent units in [White] [Tan] [Brown] [Black] [Morning Sky Gray] foamed PVC to match interior of unit; nominal 3-3/4" opening.
- Optional window opening control device available for field installation. Device allows window to open less than 4" with normal operation, with a release mechanism that allows the sash to open completely. Complies with ASTM F2090-10.
- Optional field applied Duracast sash lift available for vent units in [White] [Tan] [Brown] [Black] [Morning Sky Gray].

(1) Foam insulation inserts are not available with clear glazing.

(2) Dual-color finish is not available on products with integral nailing fin.

(3) Obscure glazing is not available when AdvancedComfort Low-E coated IG is specified.

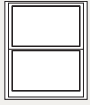

DOUBLE-HUNG

UNIT SECTIONS

Installation Types



STANDARD
BLOCK FRAME

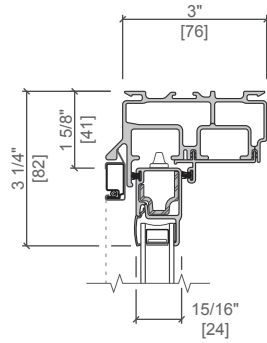

INTEGRAL
NAILING FIN

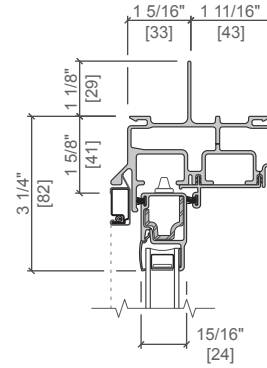

STANDARD
BLOCK FRAME
with STANDARD FIN

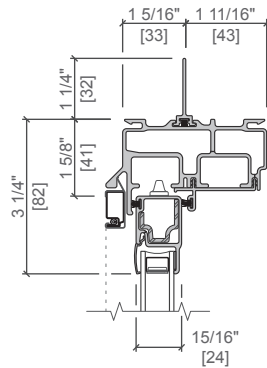

STANDARD
BLOCK FRAME
with OFF SET FIN

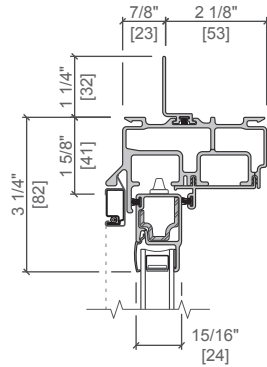

DP 50
UPGRADE

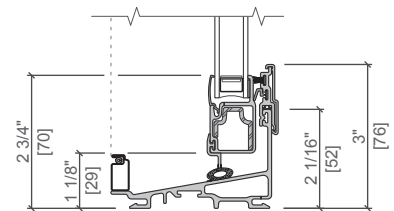

Scale 3" = 1' 0"
All dimensions are approximate.

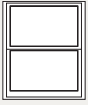

DOUBLE-HUNG

UNIT SECTIONS

Block Frame

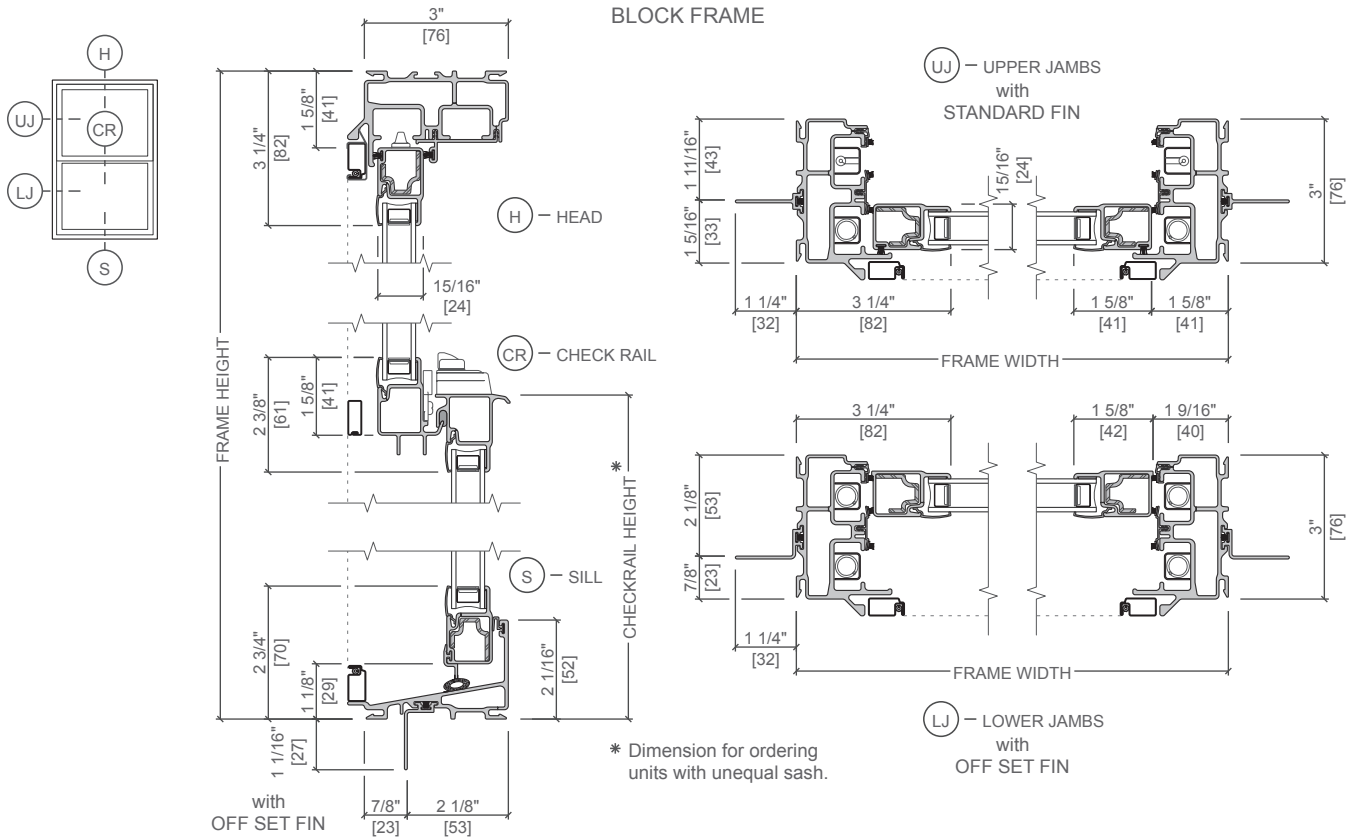

TYPICAL JOINING MULLION

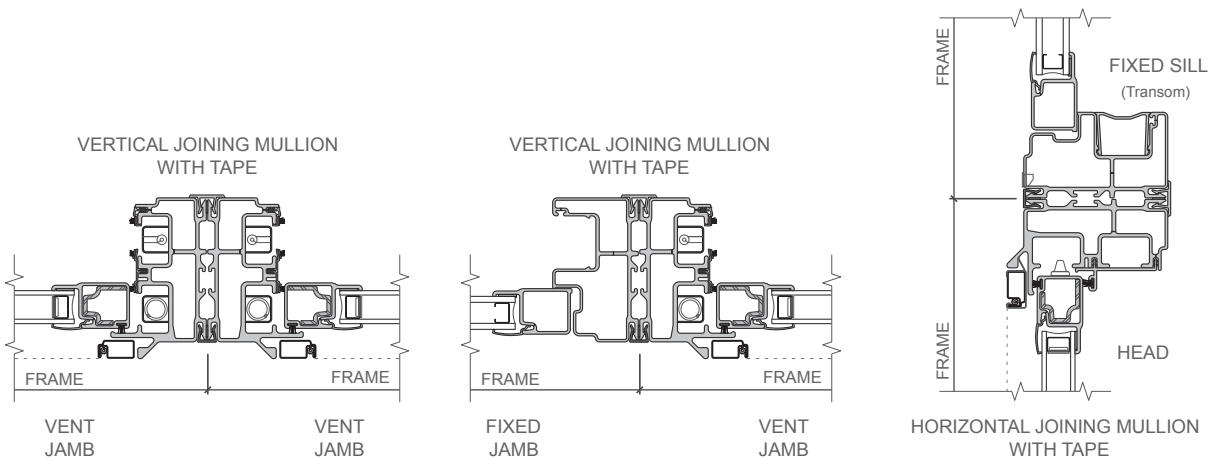

Scale 3" = 1' 0"
All dimensions are approximate.

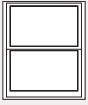

DOUBLE-HUNG

UNIT SECTIONS

Integral Nailing Fin

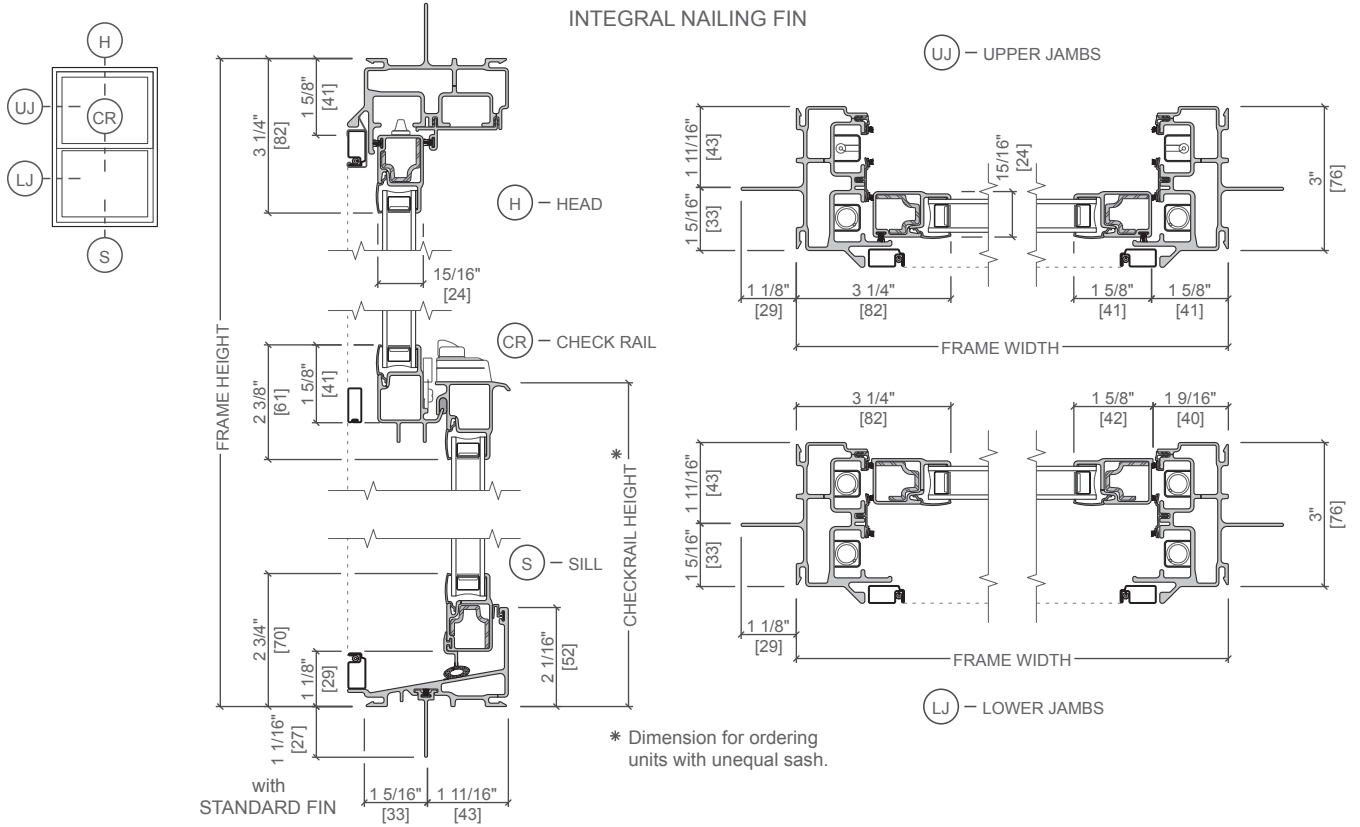

Scale 3" = 1' 0"
All dimensions are approximate.