

INDEX

Hurricane Resistant Doors 6.1

- H16, H14 Flush Doors
- HE16 Embossed Doors
- Hurricane Resistant Approvals

Tornado Resistant Systems 6.2

- PW14 Doors
- FP14 Flush Frames
- Tornado Resistant Approvals



GENERAL INFORMATION

Steelcraft doors and frames are designed for virtually all construction requirements in commercial building applications. Their construction, durability and flexibility have been proven in both operation and physical testing of all types.

Storm Resistance H and HE-Series:

The Hurricane (H and HE Series) exterior doors are suitable for installation in all types of building construction, but are specifically designed to resist cyclic and static wind pressures, and windborne debris impact loads, as prescribed by the Florida Building Code. The continuously bonded cores and full height mechanically interlocked edge seams provide attractive, flat and very durable doors to the commercial construction industry. Many options are available in this product series including edge construction, core variations and finishes.

Information on the Florida Building Code is available through the Florida Department of Community Affairs and the Florida Building Commission 2555 Shumard Oak Boulevard, Tallahassee, Florida 32399-210 (<http://www.dca.state.fl.us>)

Approvals and Geographic Applications:

Steelcraft has conducted extensive testing on various product configurations to meet the severe storm applications related to coastal areas exposed to the ravages of extreme high windstorm systems. Inland and Coastal storm regions are designated by FEMA and local codes. Products and approvals fall into the following categories:

- **Inland Regions with less severe exposure to windstorm damage.** Tests and approvals are based on structural uniform load methods. Several standard frame and door constructions have been successfully tested to meet the requirements for Inland Regions.
- **Wind-Borne Debris (Coastal) Regions with severe exposure to storm damage.** Tests and approvals are based on the Florida Building Code Test Protocols for High Velocity Hurricane Zone (HVHZ) TAS 201, TAS 202 & TAS 203. Steelcraft H-Series door constructions have been tested and meet the requirements for Coastal Regions.
- **Enhanced Hurricane Protection Area (EHPA)** – typically found in educational facilities, constructed in accordance with the State Requirements for Educational Facilities (SREF) and Florida Building Code. EHPA requirements include resistance to higher windload pressures and windborne debris impacts.

Steelcraft H-Series door assemblies have been tested and meet the requirements for EHPA.

Refer to the Hurricane Resistant Approval pages of this manual for applicable products.

SIZES AND PERFORMANCE

All doors and frames are manufactured and supplied to meet the dimensional standards and performance levels as published in ANSI A250.8-2003 (SDI 100).

Special size products are available to meet the unique construction, performance and aesthetic requirements of the architectural community. Contact Steelcraft for those requirements.

USAGE AND APPLICATION

To help simplify the use, selection and specification of Steelcraft storm resistant door products, the following guidelines for base material selection can be used:

Material Gage – the following base material thickness values were taken from the Underwriters Laboratories, Inc. publication for gage number and equivalent thickness and describe the sheet steel products available from Steelcraft:

- **H and HE Series Doors - 16 Gage [0.053" (1.3mm)]** for Extra Heavy Commercial and Institutional applications having the potential of very high use.
- **H-Series Doors - 14 Gage [0.067" (1.7mm)]** for Extra Heavy Commercial and Institutional applications with extremely high use.

Material Selection –

- Galvanized Steel – conforming to ASTM A924 and ASTM A653 is standard on all H and HE-Series doors.

INSTALLATION:

Installation of all Steelcraft frames and doors shall conform to the published Steelcraft installation instructions, ANSI A250.11-2001 (formerly SDI 105) Recommended Erection Instructions for Steel Frames and HMMA 840.

Installation of all H and HE-Series doors must conform to corresponding Miami-Dade County Notice of Acceptance (NOA) and/or the Florida Building Code (FBC) statewide approval.

All Fire Rated doors must be installed in accordance with the National Fire Protection Association Pamphlet 80 (NFPA 80), and/or the local Authority Having Jurisdiction.



ABOUT THE PRODUCT

The H16 and H14 Series Doors have been specifically designed and tested to meet the performance-based provisions of the Florida Building Code (FBC) while providing architects, designers and building owners with the broadest choices for their specific applications.

Specifiable options include glass lights, transom and sidelights, louvers, exit hardware, cylindrical or mortise single point locks, as well as a variety of door core and edge construction options.

All H Series doors have been tested to protocols TAS 201, 202 and 203, indicating their ability to withstand the missile impact, structural load and cyclic wind pressure tests prescribed by the Codes.

INSTALLATION:

1. Installation shall conform to the published Steelcraft installation instructions, ANSI A250.11-2001 (formerly SDI 105) Recommended Erection Instructions for Steel Frames and HMMMA 840.
2. Fire Rated Assemblies must be in accordance with NFPA Pamphlet 80. The Authority Having Jurisdiction is the final authority in issues related to the installation and use of installed Fire Rated Doors.

DESIGN PRESSURE RATINGS and HARDWARE CONFIGURATIONS:

Design Pressure Ratings are based on ongoing testing for door, frame and hardware configurations. Applications are limited to the configurations tested. For up to date information, please reference the Steelcraft website at www.steelcraft.com

FEATURES AND BENEFITS:

Steelcraft's H Series Doors offer the following standard unique features, which enhance long term performance and durability:

1. **A-60 Galvannealed steel** face sheets
2. **Core Systems** that enhance structural integrity:
 - **Honeycomb** (Standard) – 1" (25mm) cell kraft honeycomb configuration that increases structural integrity while reducing overall weight
 - **Polystyrene** (optional) – enhanced thermal performance
 - **Polyurethane** (optional) – extreme thermal performance
 - **Mineral Board** (optional) – rigid, temperature rise control
 - **Steel Stiffened** (optional) – welded hat section stiffeners
3. **Full Height, Epoxy Filled Mechanical Interlock Edges** provide structural support and stability the full height of the door edges.
4. **Full Height Lock Side Reinforcement Channel** ensures structural stability and locking hardware functionality under extreme pressure conditions.
5. **Universal Hinge Preparations** (patented) allow for easy field conversion from standard weight .134" (3.3mm) hinges to heavy weight .180" (4.7mm) hinges.
6. **14 Gage [0.067" (1.7mm)] Top and Bottom Channels** provide stability and protection for the top and bottom edges from abuse.
7. **3/8" undercut** is standard on all H-Series doors, to accommodate hurricane code requirements.
8. **Beveled Hinge and Lock Edges** allow for tighter installation tolerances, ensure easier operation and eliminate binding and sticking.
9. **Recessed Designer™ Glass Trim** provides a clean, neat and flush finish with the door surface.
10. **Screwed-in top caps** provide additional weather protection to exclude water and debris from exterior outswing doors.
11. **Factory Applied Baked-On Rust Inhibiting Primer** paint in accordance with ANSI A250.10-1998 (R2004).

SPECIFICATION COMPLIANCE:

1. Door construction for Steelcraft H Series Full Flush Doors meets the requirements of ANSI A250.8-2003 (SDI 100).
2. Hardware preparations and reinforcements are in accordance with ANSI A250.6-2003. Locations are in accordance with ANSI/DHI A115.
3. Florida Building Code test protocols TAS 201, TAS 202 & TAS 203.

FLORIDA BUILDING CODE LABEL:

A Florida Building Code Label is applied to all H Series doors. An optional Miami-Dade County label is also available.

FIRE RATINGS:

Steelcraft H Series Doors meet fire rating requirements. They are listed for installations requiring compliance to both neutral pressure testing UL-10B and positive pressure standard UL-10C.

Rigid Honeycomb Core

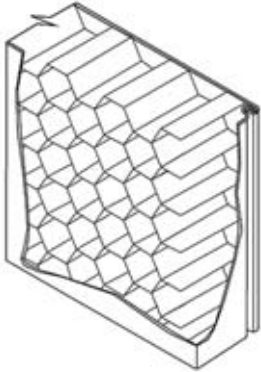

Standard H Series Core

- 1" (25mm) cell, 99 pound Kraft honeycomb
- honeycomb surfaces sanded for maximum adhesion
- impregnated with phenolic resin (resists mildew and vermin)
- laminated to both face sheets with contact adhesive
- assembled door is run through high pressure pinch rollers, achieving ultimate bond

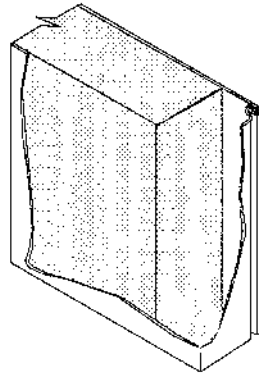

Optional Polystyrene Core

- 1 pound (453.6g) per ft³ density slab
- laminated to both face sheets with contact adhesive
- Labeled applications

Optional Polyurethane Core

- 1.8 pound (816.5g) per ft³ density slab
- laminated to both face sheets with contact adhesive
- Non-Labeled applications

Optional Mineral Fiber Board Core

- 250°F (121°C) Temperature Rise rating

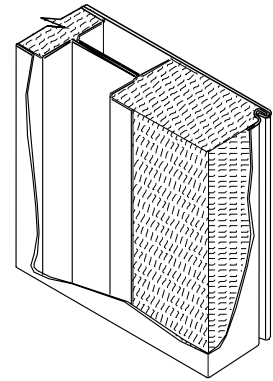

Optional Steel Stiffened Core

- stiffeners welded to inside of face sheets
 - located 6" (152.4mm) on center
 - welded to face sheet 4" (101.6mm) on center
- stiffeners welded to each other at the top and bottom
- areas between stiffeners filled with 1 pound (453.6g) per ft³ density fiberglass batt insulation

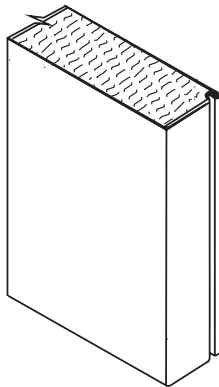

STANDARD Edge Construction

- Beveled hinge & lock edges
- Full height mechanical interlock with adhesive
- Visible edge seam standard
- Seamless edge optional

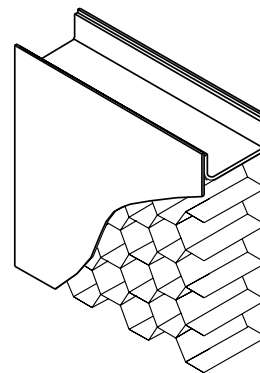

STANDARD Rigid 14 gage End Channel Construction

- 14 gage inverted galvanized top & bottom channels
- Projection welded to both face sheets
- Optional 24 gage galvanized top caps

Door Application and Usage

Series	Steel Thickness	Opening	Usage Frequency ¹	
H16	16 Ga (1.3 mm)	Exterior - Galvanized Steel	Extra Heavy Duty	Extra Heavy Commercial & Institutional applications with potential of very high use
H14	14 Ga (1.7 mm)	Exterior - Galvanized Steel	Maximum Duty	Extra Heavy Commercial & Institutional applications with extremely high use

Standard Hardware Preparations

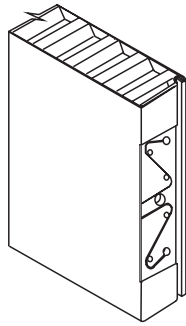

Universal Mortise Hinge Prep

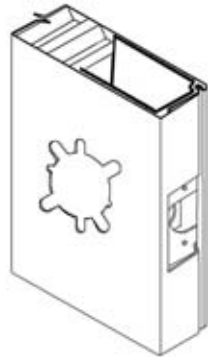

61L Lock Preparation

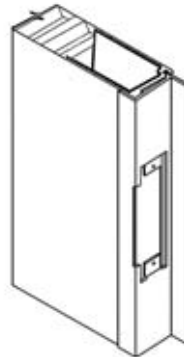

Inactive Leaf: ASA Strike Preparation

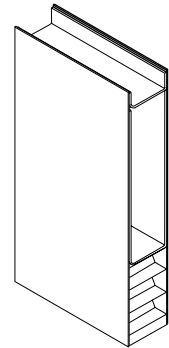

Optional 14 Gage Closer Reinforcement

Standard: mortised and reinforced for

- Patented Universal hinge preparations allow for easy field conversion from standard 4-1/2" (114mm) x .134" (3.3mm) standard weight hinges to 4-1/2" (114mm) x .180" (4.7mm) heavy weight hinges. Optional hinge preparation for 5" (127mm) x .146" (3.7mm) standard weight hinges or for 5" (127mm) x .190" (4.8mm) heavy weight hinges is also available.
- The cylindrical 161, 61L and mortise 86 lock preps are the most commonly used active leaf preparations. The 4-7/8" (124mm) strike prep is the most commonly used inactive leaf preparation.
- Optional reinforcements for surface closers are available.

Door Sizes and ANSI A250.8 Conversions

Steelcraft product selection for H Series Doors has been matched to SDI designations for Level and Model. Recommended minimum frame gage also applies to the frequency of operation of the opening.

Door Sizes and ANSI A250.8 Conversions

Series	ANSI A250.8 - SDI 100			Edge Construction Options	Maximum Sizes		Recommended Gage of Frame
	Level	Model	Description		Single	Pair	
Level 3 - Extra Heavy Duty Commercial & Institutional							
H16	3	1	Full Flush	Visible	4'-0" x 8'-0" 1219mm x 2438mm	8'-0" x 8'-0" 2438mm x 2438mm	14 Gage [0.067" (1.7mm)] 16 Gage [0.053" (1.3mm)]
HF16		2	Seamless	Epoxy Filled			
HW16							
Level 4 - Maximum Duty Commercial & Institutional							
H14	4	1	Full Flush	Visible	4'-0" x 8'-0" 1219mm x 2438mm	8'-0" x 8'-0" 2438mm x 2438mm	14 Gage [0.067" (1.7mm)] 12 Gage [0.093" (2.3mm)]
HF14		2	Seamless	Epoxy Filled			
HW14							

Code Compliance

- Florida Building Code test protocols TAS 201, TAS 202 & TAS 203.
- A mylar Florida Building Code label is included as standard
- Optional mylar Miami-Dade County label

DOOR EDGE CONSTRUCTION:

Optional Edge Seams available in the L Series doors:

- a. H - Standard feature includes visible edge seams with full height interlocked edges.
- b. HF - the mechanical edge seam is filled and finished prior to applying the factory primer.
- c. HW - the mechanical edge seam is welded and finished prior to applying the factory primer.

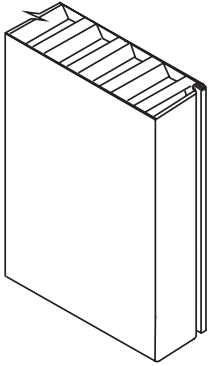

Standard Visible Seam

H Series Visible Seam Features

- 1. Full height mechanical interlock
- 2. Interlock filled with epoxy adhesive
- 3. Visible edge seam

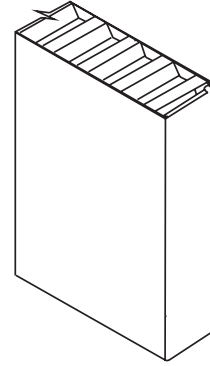

Optional Seamless Edges

HF Series Seam Filled Features

- 1. Full height mechanical interlock
- 2. Interlock filled with epoxy adhesive
- 3. Seam epoxy filled and finished
- 4. No visible edge seam

HW Series Seam Welded Features

- 1. Full height mechanical interlock
- 2. Edge seam welded 1" (25mm) long, 2" on center.
- 3. No visible edge seam

Glass Light Options – Refer to the Lights section for further details

Glazing Detail

Standard Designer Trim for 1/4" thick glass, optional 1/2" thick glass

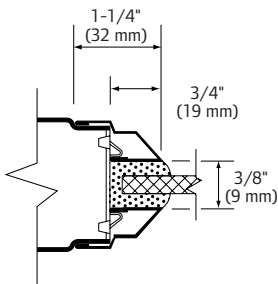

Typical Optional Overlapping Steel Trim for Glass Over 1/4" to 5/8" or 3/4" to 1" Thick

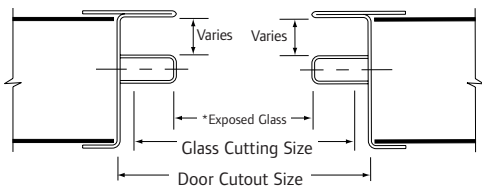

Divider Muntins Are Not Available

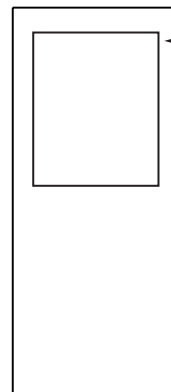

Note: Glazing type and thickness vary per job requirements.

Note: Glazing material and methods of glazing are subject to approval by applicable authorities and may change without notice. Refer to the applicable product approvals.



ABOUT THE PRODUCT:

The HE16 Series Embossed Panel Doors have been specifically designed and tested to meet the performance-based provisions of the Florida Building Code (FBC) while providing architects, designers and building owners with the broadest choices for their specific applications.

Specifiable options to meet application, specification and performance requirements include mechanical and electrical hardware preparations for exit hardware, cylindrical or mortise single point locks and double locks. No glass lights are allowable.

All HE16 Series doors have been tested to protocols TAS 201, 202 and 203, indicating their ability to withstand the missile impact, structural load and cyclic wind pressure tests prescribed by the Codes.

INSTALLATION:

1. Installation shall conform to the published Steelcraft installation instructions, ANSI A250.11-2001 (formerly SDI 105) Recommended Erection Instructions for Steel Frames and HMMA 840.
2. Fire Rated Assemblies must be in accordance with NFPA Pamphlet 80.

The Authority Having Jurisdiction is the final authority in issues related to the installation and use of installed Fire Rated Doors.

DESIGN PRESSURE RATINGS and HARDWARE CONFIGURATIONS:

Design Pressure Ratings are based on ongoing testing for door, frame and hardware configurations. Applications are limited to the configurations tested. For up to date information, please reference the Steelcraft website at www.steelcraft.com

FEATURES AND BENEFITS:

Steelcraft's HE16 Series Doors offer the following standard unique features, which enhance long term performance and durability:

1. **A-40 Galvannealed Steel** face sheets.
2. **Polystyrene Core** (Standard) - enhances the structural integrity of the door with enhanced thermal capabilities
3. **Full Height, Epoxy Filled Mechanical Interlock Edges** provide structural support and stability the full height of the door edges.
4. **Full Height Lock Side Reinforcement** Channel ensures structural stability and locking hardware functionality under extreme pressure conditions.
5. **Universal Hinge Preparations** (patented) allow for easy field conversion from standard weight .134" (3.3mm) hinges to heavy weight .180" (54.7mm) hinges.
6. **14 Gage [0.067" (1.7mm)] Inverted Top and Bottom Channels** provide stability and protection for the top and bottom edges from abuse.
7. **3/8" undercut** is standard on all H-Series doors, to accommodate hurricane code requirements.
8. **Beveled Hinge and Lock Edges** allow for tighter installation tolerances, ensure easier operation and eliminate binding and sticking.
9. **Screwed-in top caps** provide additional weather protection to exclude water and debris from exterior outswing doors.
10. **Factory Applied Baked-On Rust Inhibiting Primer** paint in accordance with ANSI A250.10-1998 (R2004).

SPECIFICATION COMPLIANCE:

1. Door construction for Steelcraft HE16 Series Embossed Panel Doors meets the requirements of ANSI A250.8-2003 (SDI 100).
2. Hardware preparations and reinforcements are in accordance with ANSI A250.6-2003. Locations are in accordance with ANSI/DHI A115.
3. Door construction for the HE16 Series Embossed Panel Doors meets ANSI A117.1-1998 (ADA) requirements for minimum 10" (254mm) bottom rail height measured from the floor.
4. Florida Building Code test protocols TAS 201, TAS 202 & TAS 203.

FLORIDA BUILDING CODE LABEL:

A Florida Building Code Label is applied to all H Series doors. An optional Miami-Dade County label is also available.

FIRE RATINGS:

Steelcraft HE16 Series Doors meet fire rating requirements.

They are listed for installations requiring compliance to both neutral pressure testing UL-10B and positive pressure standard UL-10C.

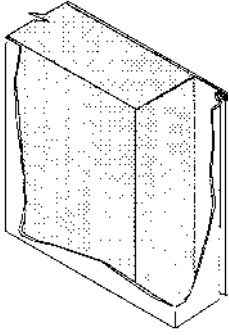

Insulated Core

- 1 pound (453.6g) per ft³ density slab
- Preferred for extreme temperature variations
- Laminated to both face sheets with contact adhesive
- Assembled door is run through high pressure pinch rollers achieving ultimate bond

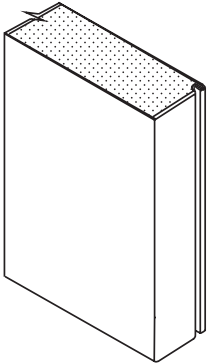

Standard Edge Construction

- Beveled hinge & lock edges
- Full height mechanical interlock with adhesive
- Visible edge seam standard
- Seamless edge optional

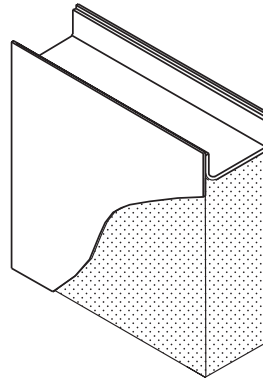

Standard Rigid 14 gage End Channel Construction

- 14 gage inverted galvanized top & bottom channels
- Projection welded to both face sheets
- Optional 24 gage galvanized top caps

Door Application and Usage

Series	Steel Thickness	Opening	Usage Frequency ¹	
HE16	16 Ga (1.3 mm)	Exterior - Galvanized Steel	Extra Heavy Duty	Extra Heavy Commercial & Institutional applications with potential of very high use

Standard Hardware Preparations

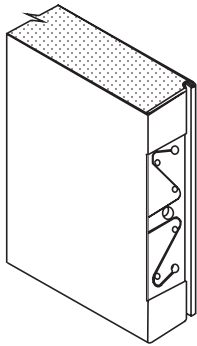

Standard Mortise Hinge Prep
4-1/2" x .134" or
4-1/2" x .180"

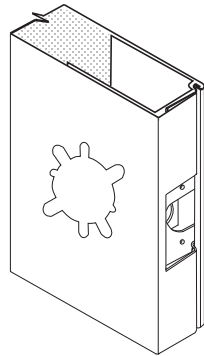

61L Lock Preparation

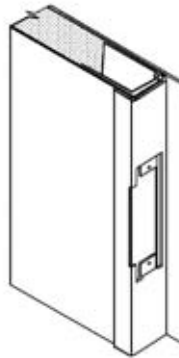

**Inactive Leaf:
ASA Strike Preparation
and Astragal**

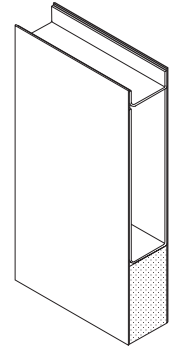

**Optional 14 Gage
[0.067" (1.7mm)]
Closer Reinforcement**

Standard: mortised and reinforced for

- Patented Universal hinge preparations allow for easy field conversion from standard 4-1/2" (114mm) x .134" (3.3mm) standard weight hinges to 4-1/2" (114mm) x .180" (4.7mm) heavy weight hinges. Optional hinge preparation for 5" (127mm) x .146" (3.7mm) standard weight hinges or for 5" (127mm) x .190" (4.8mm) heavy weight hinges is also available.
- The cylindrical 161, 61L and mortise 86 lock preps are the most commonly used active leaf preparations. The 4-7/8" (124mm) strike prep is the most commonly used inactive leaf preparation.
- Optional reinforcements for surface closers are available.

SDI Conversion Chart

Steelcraft product selection for HE Series Doors has been matched to SDI designations for Level and Model. Recommended minimum frame gage also applies to the frequency of operation of the opening.

Door Sizes and ANSI A250.8 Conversions

Series	ANSI A250.8 - SDI 100			Edge Construction Options	Maximum Sizes		Recommended Gage of Frame
	Level	Model	Description		Single	Pair	
Level 3 - Extra Heavy Duty Commercial & Institutional							
HE16	3	1	Full Flush	Visible	3'-0" x 8'-0"	6'-0" x 8'-0"	14 Gage [0.067" (1.7mm)]
HEF16		2	Seamless	Epoxy Filled	914mm x 2438mm	1829mm x 2438mm	16 Gage [0.053" (1.3mm)]

Code Compliance

- Florida Building Code test protocols TAS 201, TAS 202 & TAS 203.
 - A mylar Florida Building Code label is included as standard
 - Optional mylar Miami-Dade County label

DOOR EDGE CONSTRUCTION:

Optional Edge Seams available in the L Series doors:

- a. H - Standard feature includes visible edge seams with full height interlocked edges.
- b. HF - the mechanical edge seam is filled and finished prior to applying the factory primer.

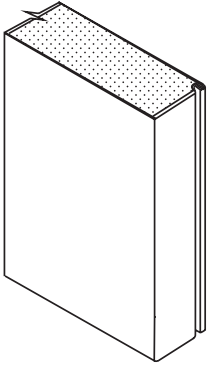

Standard Visible Seam

HE Series Visible Seam Features

1. Full height mechanical interlock
2. Interlock filled with epoxy adhesive
3. Visible edge seam

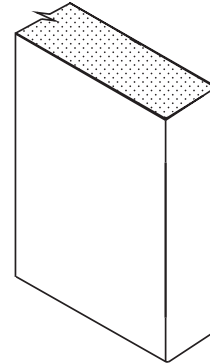

Optional Seamless Edges

HEF Series Seam Filled Features

1. Full height mechanical interlock
2. Interlock filled with epoxy adhesive
3. Seam epoxy filled and finished
4. No visible edge seam

INLAND REGIONS - Tested in accordance with ASTM E-330

FLUSH DOORS – LOCKING APPLICATIONS



Single Door

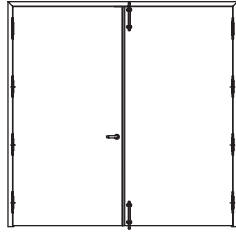

Double Door

Maximum Door Size:

- Singles: 4' 0" x 8' 0"
- Pairs: 8' 0" x 8' 0"

Hardware Application:

- Active: Cylindrical or Mortise locks
- Inactive: Ives Surface or Flush Bolts

Door Design: Flush doors only

LOCK TYPE	LOCK SERIES			Florida Approval	Design Pressure	Door Series
	Schlage		Falcon			
	Mechanical	Electronic				
Cylindrical (Bored)	ND, AL, A, S	5100	T, B, X, Z, S, H	FL10356	+/- 50 PSF	L, B, CE
Mortise	L9000 L9400	5500	T, B, X, Z, S, H	FL10356	+/- 50 PSF	L, B, CE

FLUSH DOORS – EXIT ALARM APPLICATIONS

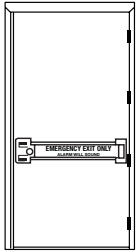

Single Door Only

Maximum Door Size:

- Singles: 4' 0" x 8' 0"
- Pairs are not available

Hardware Application:

- 2670 GUARD-X Alarm Lock

Door Design: Flush doors only

EXIT TYPE	EXIT SERIES		Florida Approval	Design Pressure	Door Series
	Von Duprin	Monarch			
Alarm	2670 GUARD-X Alarm Lock	No	FL10356	+ 55 PSF - 40 PSF	L, B, CE, T

DOORS WITH GLASS LIGHTS – EXIT ALARM APPLICATIONS

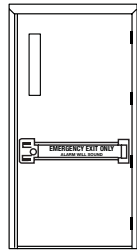
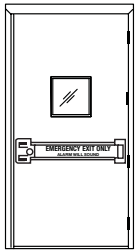

Single Door Only

Maximum Door Size:

- Singles: 4' 0" x 8' 0"
- Pairs are not available

Hardware Application:

- 2670 GUARD-X Alarm Lock

Door Design: V or N3 glass designs only

EXIT TYPE	EXIT SERIES		Florida Approval	Design Pressure	Door Series
	Von Duprin	Monarch			
Alarm	2670 GUARD-X Alarm Lock	No	FL10356	+ 55 PSF - 40 PSF	L, B, CE, T

FLUSH DOORS - EXIT DEVICE APPLICATIONS

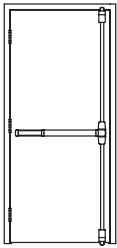

Single Door

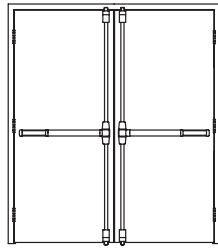

Double Door

Maximum Door Size:

- Singles: 4' 0" x 8' 0"

- Pairs: 8' 0" x 8' 0"

Hardware Application:

- Exit Device As Noted Below

Door Design: Flush doors only

EXIT TYPE	EXIT SERIES		Florida Approval	Design Pressure	Door Series
	Von Duprin	Monarch			
RIM	33A, 55, 88	17-R, 18-R 19-R, XX-R	FL10356	± 50 PSF	L, B, CE, T
	22, 99/98	No		+50/-40 PSF	
SVR	2227, 3327A, 3527A, 8827 8827, 9927	No	FL10356	+50/-40 PSF	L, B, CE, T
	No	17-V, 18-V, 19-V, XX-V		± 50 PSF	
CVR	3347A, 3547A, 9447, 9847, 9947	No	FL10356	± 50 PSF	L, B, CE, T
	No	17-C, 18-C, 19-C, XX-C		± 60 PSF	
	5547	No			
3 POINT	9957	No	FL10356	+50/-40 PSF	L, B, CE, T
	No	17-TPL, XX-TPL		± 50 PSF	
Mortise Single Door Only	8875, 9475 9575, 9875, 9975	No	FL10356	+ 50/ -45 PSF	L, B, CE, T
	No	17M, 18M, XX-M		± 50 PSF	

INLAND REGIONS - Tested in accordance with ASTM E-330

DOORS WITH GLASS LIGHTS – LOCKING APPLICATIONS

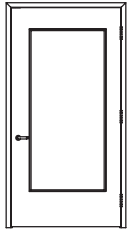

Single Door

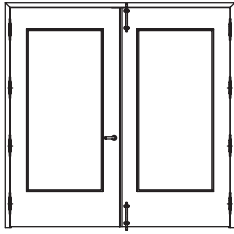

Double Door

Maximum Door Size:

- Singles: 4' 0" x 8' 0"
- Pairs: 8' 0" x 8' 0"

Hardware Application:

- Active: Cylindrical or Mortise locks
- Inactive: Ives Surface or Flush Bolts

Door Design: FG, FG2, FG3, G,V, N, N3, N4, LNL glass designs only

Approved Glass: Refer to the appropriate Florida Approval for glass and glazing types

LOCK TYPE	LOCK SERIES			Florida Approval	Design Pressure	Door Series
	Schlage		Falcon			
	Mechanical	Electronic				
Cylindrical (Bored)	ND, AL, A, S	No	T, B, X, Z, S, H	FL10356	+50 / -40 PSF	L, B, CE, T
Mortise	L9000/9400 LV9000/9400	No	M	FL10356	+50 / -40 PSF	L, B, CE, T

DOORS WITH GLASS LIGHTS – EXIT DEVICE APPLICATIONS

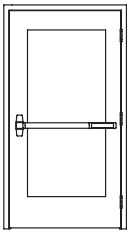

Single Door

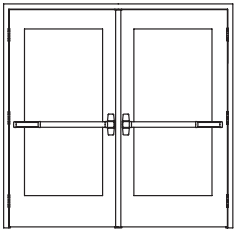

Double Door

Maximum Door Size:

- Singles: 4' 0" x 8' 0"
- Pairs: 8' 0" x 8' 0"

Hardware Application:

- RIM Exit Devices as noted below

Door Design: FG, FG2, FG3, G, V, N, N3, N4, LNL glass designs only

Approved Glass: Refer to the appropriate Florida Approval for glass and glazing types

EXIT TYPE	EXIT SERIES		Florida Approval	Design Pressure	Door Series
	Von Duprin	Monarch			
RIM	22, 33A, 55, 88, 99	17-R, 18-R, 19-R, XX-R	FL10356	+ 50 PSF - 40 PSF	L, B, CE

BORROWED LIGHT ELEVATIONS

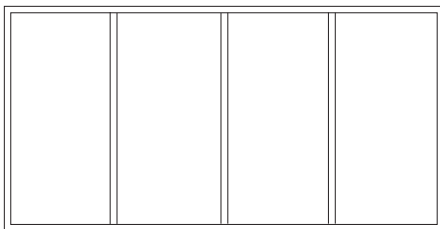

Maximum Overall Frame Size:

14' 8" (W) x 10' 2" (H)

Approved Glass: Refer to the appropriate Florida Approval for glass and glazing types

Florida Approval	Design Pressure
FL4622	± 60 PSF

WIND-BORN DEBRIS (COASTAL) REGIONS

Tested in accordance with Florida Building Code test:

- Protocols (TAS 201, TAS 202 & TAS 203)
- Missile impact and ASTM E-330 applications

FLUSH DOORS – LOCKING APPLICATIONS

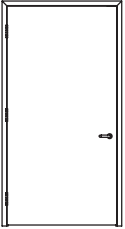

Single Door

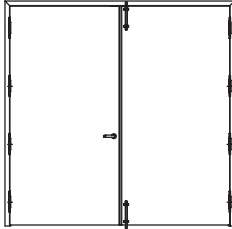

Double Door

Maximum Door Size:

- Singles: 4' 0" x 8' 0"
- Pairs: 8' 0" x 8' 0"

Hardware Application:

- Active: Cylindrical or Mortise locks
- Inactive: Ives Surface or Flush Bolts

Door Design: Flush doors only

LOCK TYPE	LOCK SERIES			Miami-Dade NOA	Florida Approval	Design Pressure	Door Series
	Schlage		Falcon				
	Mechanical	Electronic					
Cylindrical (Bored)	ND*	5100	T	Single Door <u>07-0829.04</u>	FL12400	± 75 PSF	H, HE
	ND	No	No	Double Door <u>07-0829.03</u>		± 65 PSF	
	AL	No	No	Exp. 05/05/10		± 55 PSF	
Mortise	L9400	5500	M		FL12400	± 75 PSF	H, HE

* - requires a 3/4" projection latch

FLUSH DOORS – EXIT ALARM APPLICATIONS

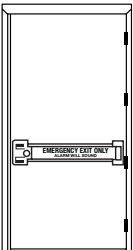

Single Door Only

Maximum Door Size:

- Singles: 4' 0" x 8' 0"
- Pairs are not available

Hardware Application:

- 2670 GUARD-X Alarm Lock

Door Design: Flush doors only

EXIT TYPE	EXIT SERIES		Miami-Dade NOA	Florida Approval	Design Pressure	Door Series
	Von Duprin	Monarch				
Alarm	2670 GUARD-X Alarm Lock	No	07-0829.04 Exp. 05/05/10	FL12400	± 55 PSF	H, HE

WIND-BORN DEBRIS (COASTAL) REGIONS

Tested in accordance with Florida Building Code test:

- Protocols (TAS 201, TAS 202 & TAS 203)
- Missile impact and ASTM E-330 applications

FLUSH DOORS – EXIT ALARM APPLICATIONS

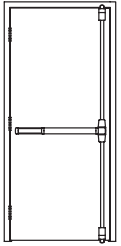

Single Door

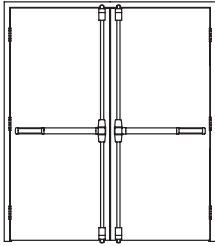

Double Door

Maximum Door Size:

- Singles: 4' 0" x 8' 0"
- Pairs: 8' 0" x 8' 0"

Hardware Application:

- Exit Device As Noted Below

Door Design: Flush doors only

EXIT TYPE	EXIT SERIES		Miami-Dade NOA	Florida Approval	Design Pressure	Door Series
	Von Duprin	Monarch				
RIM	99, 98	DL 18-R	Single Door <u>07-0829.04</u> Double Door <u>07-0829.03</u> Exp. 05/05/10	FL12400	± 70 PSF	H, HE
SVR	9927	18V		FL12400	± 70 PSF	H, HE
CVR	9947-F	F18-C		FL12400	± 70 PSF	H, HE
3-POINT	9957	No		FL12400	± 70 PSF	H, HE
Mortise Single Door Only	8857, 9957	18M		FL12400	± 70 PSF	H, HE

WIND-BORN DEBRIS (COASTAL) REGIONS

Tested in accordance with Florida Building Code test:

- Protocols (TAS 201, TAS 202 & TAS 203)
- Missile impact and ASTM E-330 applications

DOORS WITH GLASS LIGHTS – LOCKING APPLICATIONS



Single Door

Maximum Door Size:

- Singles: 3' 0" x 7' 0"
- Pairs are not available

Hardware Application:

- Active: Cylindrical or Mortise locks

Door Design: FG, FG2, FG3, G, V, N, N3, N4, LNL glass designs only

Approved Glass: Refer to the appropriate Florida Approval for glass and glazing types

LOCK TYPE	LOCK SERIES			Miami-Dade NOA	Florida Approval	Design Pressure	Door Series
	Schlage		Falcon				
	Mechanical	Electronic					
Cylindrical (Bored)	ND	5100	T	Single Door 07-0829.06	FL12400	± 70 PSF	H, HE
Mortise	L9000/9400 LV9000/9400	5500	M	Double Door 07-0829.05 Exp. 05/05/10	FL12400	± 70 PSF	H, HE

DOORS WITH GLASS LIGHTS – LOCKING APPLICATIONS

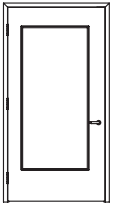

Single Door

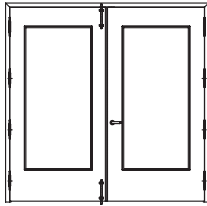

Double Door

Maximum Door Size:

- Singles: 4' 0" x 8' 0"
- Pairs: 8' 0" x 8' 0"

Hardware Application:

- Active: Cylindrical or Mortise locks
- Inactive: Ives Surface or Flush Bolts

Door Design: FG, FG2, FG3, G, V, N, N3, N4, LNL glass designs only

Approved Glass: Refer to the appropriate Florida Approval for glass and glazing types

LOCK TYPE	LOCK SERIES			Miami-Dade NOA	Florida Approval	Design Pressure	Door Series
	Schlage		Falcon				
	Mechanical	Electronic					
Cylindrical (Bored)	ND	5100	T	Single Door 07-0829.06	FL12400	± 50 PSF	H, HE
Mortise	L9400	5500	M	Double Door 07-0829.05 Exp. 05/05/10	FL12400	± 50 PSF	H, HE

DOORS WITH GLASS LIGHTS – EXIT DEVICE APPLICATIONS

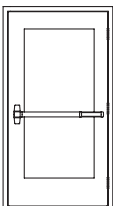

Single Door

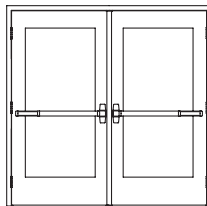

Double Door

Maximum Door Size:

- Singles: 4' 0" x 8' 0"
- Pairs: 8' 0" x 8' 0"

Hardware Application:

- RIM Exit Devices As Noted Below

Door Design: FG, FG2, FG3, G, V, N, N3, N4, LNL glass designs only

Approved Glass: Refer to the appropriate Florida Approval for glass and glazing types

EXIT TYPE	EXIT SERIES		Miami-Dade NOA	Florida Approval	Design Pressure	Door Series
	Von Duprin	Monarch				
RIM	88, 98, 99	DL-18-R	Single Door 07-0829.06 Double Door 07-0829.05 Exp. 05/05/10	FL12400	± 50 PSF	H, HE

WIND-BORN DEBRIS (COASTAL) REGIONS

Tested in accordance with Florida Building Code test:

- Protocols (TAS 201, TAS 202 & TAS 203)
- Missile impact and ASTM E-330 applications

DOORS WITH LOUVERS – LOCKING APPLICATIONS

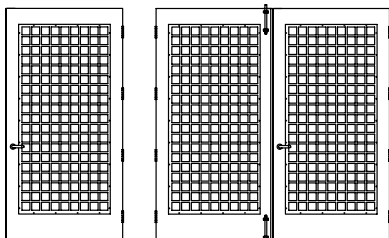

Single Door Double Door

Maximum Door Size:

- Singles: 4' 0" x 8' 0"
- Pairs: 8' 0" x 8' 0"

Hardware Application:

- Active: Cylindrical or Mortise locks
- Inactive: Ives Surface Bolts

Door Design: Louvered Doors Only

LOCK TYPE	LOCK SERIES			Miami-Dade NOA	Florida Approval	Design Pressure	Door Series
	Schlage		Falcon				
	Mechanical	Electronic					
Cylindrical (Bored)	ND	No	T	Single Door 08-0908.20 Exp. 11/13/13	FL1591-R2	± 60 PSF	H, HE
Mortise	L9000/9400 LV9000/9400	No	M	Double Door 08-0908.20 Exp. 11/13/13	FL1591-R2	± 60 PSF	H, HE

DOORS WITH LOUVERS – DEADLOCKING APPLICATIONS

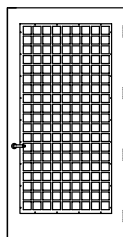

Single Door

Maximum Door Size:

- Singles: 4' 0" x 8' 0"
- Pairs are not available

Hardware Application:

- Active: Cylindrical or Mortise locks

Door Design: Louvered Doors Only

LOCK TYPE	LOCK SERIES			Miami-Dade NOA	Florida Approval	Design Pressure	Door Series
	Schlage		Falcon				
	Mechanical	Electronic					
Deadlock	B600, B700, B800	No	D400, D800	08-0908.20 Exp. 11/13/13	FL1591-R2	± 60 PSF	H, HE

WIND-BORN DEBRIS (COASTAL) REGIONS

Tested in accordance with Florida Building Code test:

- Protocols (TAS 201, TAS 202 & TAS 203)
- Missile impact and ASTM E-330 applications

TRANSOM AND SIDE LIGHTS - GLASS DOORS – EXIT DEVICE APPLICATIONS

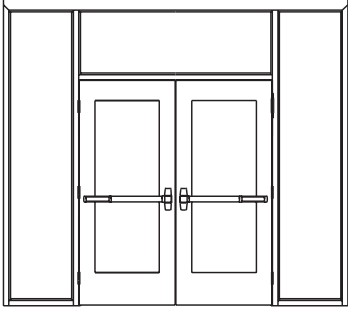

Single or Double Door

Maximum Overall Frame Size:

- 10' 8" (W) x 9' 6" (H)

Hardware Application:

- Von Duprin Exit Devices As Noted Below

Maximum Door Size:

- Singles: 3' 0" x 7' 0"
- Doubles: 6' 0" x 7' 0"

Door Design: Glass doors only FG, FG2, FG3

Approved Glass: Refer to the appropriate Florida Approval for glass and glazing types

EXIT TYPE	EXIT SERIES		Miami-Dade NOA	Florida Approval	Design Pressure	Door Series
	Von Duprin	Monarch				
RIM	99, 88	No	0-0705-03 Exp. 09/11/13	FL1592	± 60 PSF	H, HE
SVR	9927	No		FL1592	± 60 PSF	H, HE
CVR	9947-F, 3347F	No		FL1592	± 60 PSF	H, HE

BORROWED LIGHT ELEVATIONS

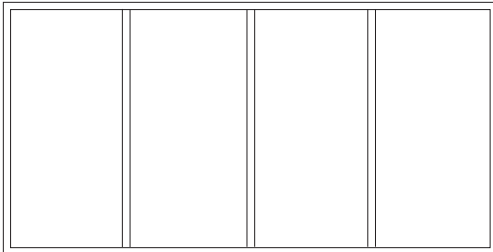

Maximum Overall Frame Size:

- 14' 8" (W) x 10' 2" (H)

Approved Glass:

Refer to the appropriate NOA or Florida Approval for glass and glazing types.

Miami-Dade NOA	Florida Approval	Design Pressure	Missile Impact
#04-0707.01 Exp. 09/30/10	FL4622	± 60 PSF	YES

EXTREME EXPOSURE - WIND-BORN DEBRIS REGIONS

Tested in accordance with Florida Building Code test:

- Protocols (TAS 201, TAS 202 & TAS 203)
- Missile impact and ASTM E-330 applications

FLUSH DOORS – LOCKING APPLICATIONS

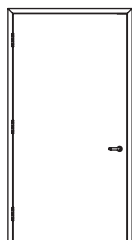

Single Door

Maximum Door Size:
 - Singles: 3' 0" x 7' 0"
 - Pairs are not available

Hardware Application:
 - Mortise Locks

Door Design: Flush doors only

LOCK TYPE	LOCK SERIES			Miami-Dade NOA	Florida Approval	Design Pressure	Door Series
	Schlage		Falcon				
	Mechanical	Electronic					
Mortise	L9400	No	M	04-0604.02 04-0927.01 Exp. 11/11/09	FL3905	±170 PSF Stainless Steel Strike ±120 PSF Standard Strike	H,HE



GENERAL INFORMATION

The **Paladin™ Series** door systems are specifically designed and tested to conform to the Federal Emergency Management Agency (FEMA) 320 and 361 guidelines and ANSI ICC500 standards providing security and safety for tornado shelters and severe storm areas of refuge.

The **PW14 Paladin™ Series** doors include unique internal steel stiffeners which are welded to the face sheets. The full height mechanically interlocked edge seams and rigid end closures are welded and provide attractive and very durable doors.

The **FP14 Paladin™ Series** frames are designed for installation in either interior or exterior locations as a part of the wall framing process. Three sided steel frames are furnished in three pieces (two jambs and a head) which are anchored to the wall systems.

HOW ARE FRAMES SUPPLIED:

The connecting corners of the 3-piece frame include precision factory die miters and interlocking tabs and corner clips. The corner miters are specially designed to insure a tight closed corner connection when installed properly. There are two methods of furnishing 3-sided frames to the jobsite:

- **Knock Down (KD)** – Frames are supplied in 3 pieces for assembly prior to installation at the jobsite by the installing contractor.
- **Set-Up and Welded (SUA)** – Prior to arriving at the jobsite, the 3-sided frame (with factory miters) is assembled (at the distributor's fabrication location, or by Steelcraft). The miters are welded (in accordance with ANSI A250.8-2003), finished and supplied to the jobsite ready for installation. SUA frames are shipped to the jobsite with temporary shipping bars attached.

SIZES AND PERFORMANCE

All doors and frames are manufactured and supplied to meet the dimensional standards and performance levels as published in ANSI A250.8-2003 (SDI 100).

Special size products are available to meet the unique construction, performance and aesthetic requirements of the architectural community. Contact Steelcraft for those requirements.

To help simplify the use, selection and specification of Steelcraft Storm Resistance door and frame products, the following guidelines for base material selection can be used:

Material Gage – the following base material thickness values were taken from the Underwriters Laboratories, Inc. publication for gage number and equivalent thickness and describe the sheet steel products available from Steelcraft:

- **14 Gage [0.067" (1.7mm)]** for Extra Heavy Commercial and Institutional applications with extremely high use.

Material Selection – in addition to the thickness of base material, the following base material types of metal are available from Steelcraft:

- **Galvannealed Steel** - conforming to ASTM A924 and ASTM A653 recommended for exterior opening or interior openings with high humidity.

INSTALLATION:

Installation of all Steelcraft frames and doors shall conform to the published Steelcraft installation instructions, ANSI A250.11-2001 (formerly SDI 105) Recommended Erection Instructions for Steel Frames and HMMA 840.

All Fire Rated doors must be installed in accordance with the National Fire Protection Association Pamphlet 80 (NFPA 80), and/or the local Authority Having Jurisdiction.

NOTE: The Paladin™ PW14 Series Flush Doors and FP14 Frame must be installed as a system.



ABOUT THE PRODUCT:

The Paladin™ PW14 Series Flush Doors and FP14 Frame have been specifically designed, tested and approved to withstand extreme wind-load and flying missile impact. Unique engineered designs combined with the durability of superior corrosive resistant steel make Steelcraft PW14 Paladin™ Series Flush Doors an excellent solution for added building protection from severe weather.

Specifiable options to meet application, specification and performance requirements include mechanical and electrical hardware preparations for exit hardware. No glass lights are allowed.

The PW14 Paladin™ Door and FP14 Frame System has been designed and tested to address the requirements of FEMA 361/320 guidelines and ANSI ICC500 standards to protect the general public from the extreme effects of tornados. For compliance with the standards, the PW14 Paladin™ Door and FP14 Frame must be supplied as a system.

INSTALLATION:

1. Installation shall conform to the published Steelcraft installation instructions, ANSI A250.11-2001 (formerly SDI 105) Recommended Erection Instructions for Steel Frames and and HMMA 840.
2. Fire Rated Assemblies must be in accordance with NFPA Pamphlet 80. The Authority Having Jurisdiction is the final authority in issues related to the installation and use of installed Fire Rated Doors.

DESIGN CRITERIA and HARDWARE CONFIGURATIONS:

Paladin™ Systems offer a range of hardware applications based on ongoing testing for door, frame and hardware configurations. Applications are limited to the configurations tested. For up to date information, please reference the Steelcraft website at www.steelcraft.com

Paladin Systems are designed and tested to withstand windborne debris impact of a 15 lbs missile travelling at 100 mph and a 250 mph design wind speed.

SYSTEM FEATURES AND BENEFITS:

DOOR: PW14 Paladin™ Series Flush Door:

1. **Steel Stiffened core construction** with 18 Gage (0.042") stiffeners welded to each face sheet.
2. **Full Height, Epoxy Filled Mechanical Interlock Edges** at lock and hinge edges with edge seams welded, filled and ground smooth provide structural support and stability the full height of the door.
3. **Full Height Lock Side Reinforcement Channel** ensures structural stability under extreme pressure conditions.
4. **Universal Hinge Preparations** (patented) allow for easy field conversion from standard weight .134" (3.3mm) hinges to heavy weight .180" (54.7mm) hinges.
5. **14 Gage (0.067") Inverted Top and Bottom Channels** with additional 12 Gage (0.093") flush channel.
6. **Beveled Hinge and Lock Edges** allow for tighter installation tolerances, ensure easier operation and eliminate binding and sticking.
7. **Factory Applied Baked-On Rust Inhibiting Primer** paint in accordance with ANSI A250.10-1998 (R2004).
8. **Standard A-60 Galvannealed Steel** face sheets for superior corrosion resistance on exterior openings

SPECIFICATION COMPLIANCE:

1. Door construction for Steelcraft PW14 Paladin™ Series Flush Doors meets the requirements of ANSI A250.8-2003 (SDI 100).
2. Hardware preparations and reinforcements are in accordance with ANSI A250.6-2003. Locations are in accordance with ANSI/DHI A115.

FEMA COMPLIANCE LABEL

Factory Label is applied to all PW14 Paladin™ Series Flush Doors and FP14 Frame System.

FIRE RATINGS:

Steelcraft PW14 Paladin™ Series Flush Doors meet the broadest fire rating requirements. They are listed for installations requiring compliance to both neutral pressure testing UL-10B and positive pressure standard UL-10C.

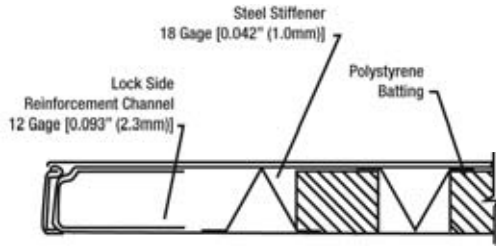

Standard PW14 Paladin Series Core

- 18 Gage (0.042") Galvannealed Steel Stiffeners welded to each face sheet
- 1 pound per ft³ density insulation inserted between the steel stiffeners
- 12 gage (0.093") reinforcement channel at the lock edge

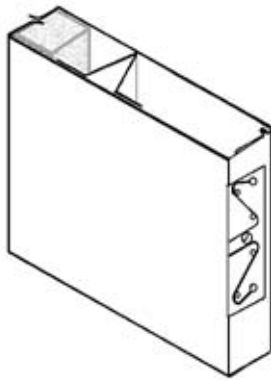

Standard 12 Gage [0.093" (2.3mm)]
Galvannealed Top Channel

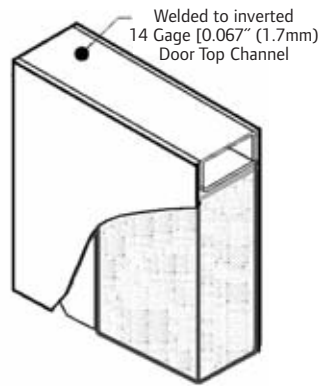

Premium Edge Construction - STANDARD

- Beveled hinge & lock edges
- Full height mechanical interlock with adhesive
- Seamless welded edge seam standard
- Lock edge with 12 gage (0.093") channel

Rigid End Channel Construction - STANDARD

- Top and bottom edges are closed with inverted 14 gage (0.067") welded channels.
- Top channel includes an additional 12 gage [0.093"] flush top channel.

Door Application and Usage

Series	Steel Thickness	Opening	Usage Frequency	
PW14	14 Ga (1.7 mm)	Interior - Galvannealed Steel Exterior - Galvannealed Steel	Maximum Duty	Tornado resistance in accordance with FEMA 361 and ANSI ICC500 standards

Door Sizes and ANSI A250.8 Conversions

Series	ANSI A250.8 - SDI 100			Edge Construction Options	Maximum Sizes		Recommended Gage of Frame
	Level	Model	Description		Single	Pair	
PW14			Not Applicable	Welded	4'-0" x 9'-0" 1219mm x 3150mm	8'-0" x 9'-0" 2438mm x 3150mm	14 Gage [0.067" (1.7mm)]

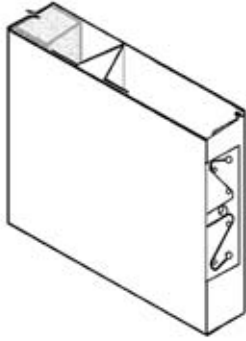

Universal Mortise Hinge Prep
 4-1/2" (114mm) x .134" (3.3mm)
 or x .180" (4.7mm) or Optional
 5" (127mm) x .146" (3.7mm)
 or x .190" (4.8mm)

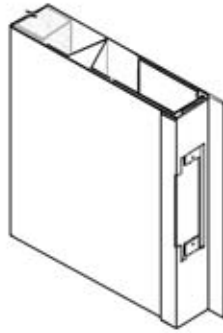

Inactive Leaf:
 ASA Strike Preparation and Astragal

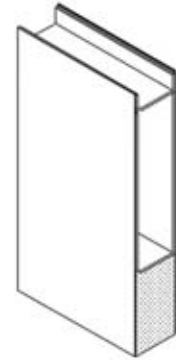

Standard 14 Gage
 [0.067" (1.7mm)]
 Closer Reinforcement

Standard: mortised and reinforced for

- Patented Universal hinge preparations allow for easy field conversion from standard 4-1/2" (114mm) x .134" (3.3mm) standard weight hinges to 4-1/2" (114mm) x .180" (4.7mm) heavy weight hinges. Optional hinge preparation for 5" (127mm) x .146" (3.7mm) standard weight hinges or for 5" (127mm) x .190" (4.8mm) heavy weight hinges is also available.
- Hardware configurations that are compliant with FEMA 361 are acceptable for use with the Paladin System. Mounting tabs for the ASA 4-7/8" (124mm) mortise strike are attached to the door edge for direct mounting; the astragal is cut-out only for the flush mounting of the strike to the door. There are no tabs attached to the astragal.
- Reinforcements for surface Closers are furnished as standard. Reinforcements for Surface Bolts are available.

Meeting Edge Details for Pairs of PW14 Paladin' Series Doors

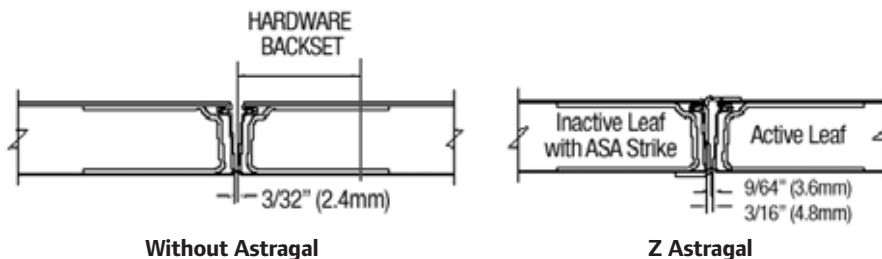

Code Compliance

- FEMA 361/320 guidelines and ANSI ICC500 standards
- To protect the general public from extreme effects of tornados
 - A mylar Paladin' label is included as standard

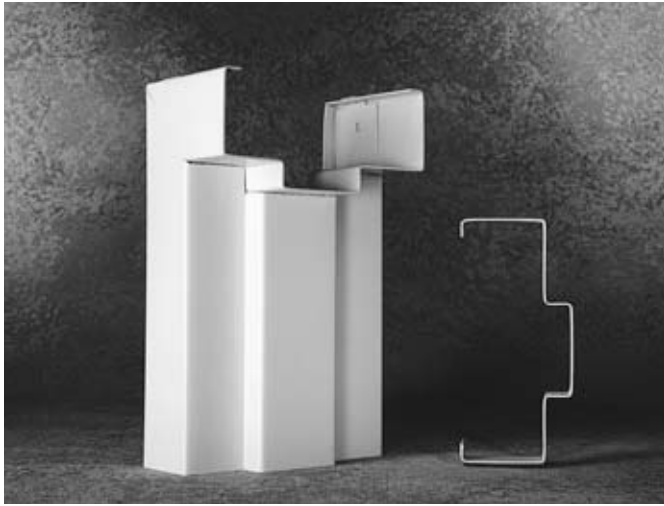

ABOUT THE PRODUCT:

The FP14 Paladin™ Series 3 Sided Flush Frames are designed to meet requirements of FEMA 320 and 361 guidelines to protect the general public from the extreme effects of tornados. These frames are available in 14 gage [0.067" (1.7mm)] only. They are installed in both interior and exterior locations, and in virtually all types of buildings and wall constructions. These frames are to be installed as part of the wall framing sequence. They can be specified and supplied as KD (knock-down) for field assembly prior to installation or SUA (set-up and welded) for installation as a pre-welded unit. All FP14 Paladin Series frames include the FEMA 320 / 361 Label.

INSTALLATION:

1. Installation shall conform to the published Steelcraft installation instructions, ANSI A250.11-2001 (formerly SDI 105) Recommended Erection Instructions for Steel Frames and HMMA 840.
2. Fire Rated Assemblies must be in accordance with NFPA Pamphlet 80. The Authority Having Jurisdiction is the final authority in issues related to the installation and use of installed Fire Rated Doors.

FEATURES AND BENEFITS:

Steelcraft FP14 Paladin™ Series Flush Frames offer the following unique features which enhance long term functionality and durability:

1. **14 GAGE A60 galvanized steel for superior corrosion resistance** on exterior openings.
2. **Die-mitered corner connections** at the head and jamb. Standard corners insure attractive, tight and closed miters.
3. **Patented universal hinge preparations** allow for easy field conversion from standard weight .134" (3.3mm) thick hinges to heavy weight .180" (4.7mm) hinges.
4. **Adjustable base anchors** allow for installation adjustment when the floor is not level.
5. **Factory prepared** for field installed silencers.
6. **Factory applied baked on rust inhibiting**

SPECIFICATION COMPLIANCE:

1. Overall frame construction for the Steelcraft FP14 Paladin™ Series Flush Frames meets the requirements of ANSI A250.8-2003 (SDI -100).
2. Hardware preparations and reinforcements are in accordance with ANSI A250.6-2003. Locations are in accordance with ANSI/DHI A115.

FIRE RATINGS:

The FP14 Paladin™ Series Flush Frames meet fire rating requirements. They are listed for installations requiring compliance to both neutral pressure testing UL 10B and positive pressure standard UL 10C. Refer to the "Fire Rated" Section of this manual for particular listings.

APPLICATIONS:

FP14 Paladin™ Series Flush Frames are typically installed in wall construction types as defined in the chart below:

Frame Applications

Profile	Steel Thickness	Wall Construction	Typical Wall Anchors
FP14	14 Gage [0.067" (1.7mm)]	Masonry	Wire Masonry
	Existing Masonry	Bolted Through Soffit	

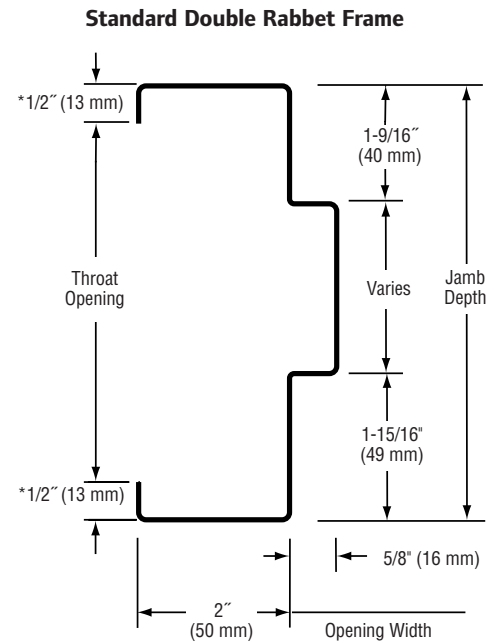
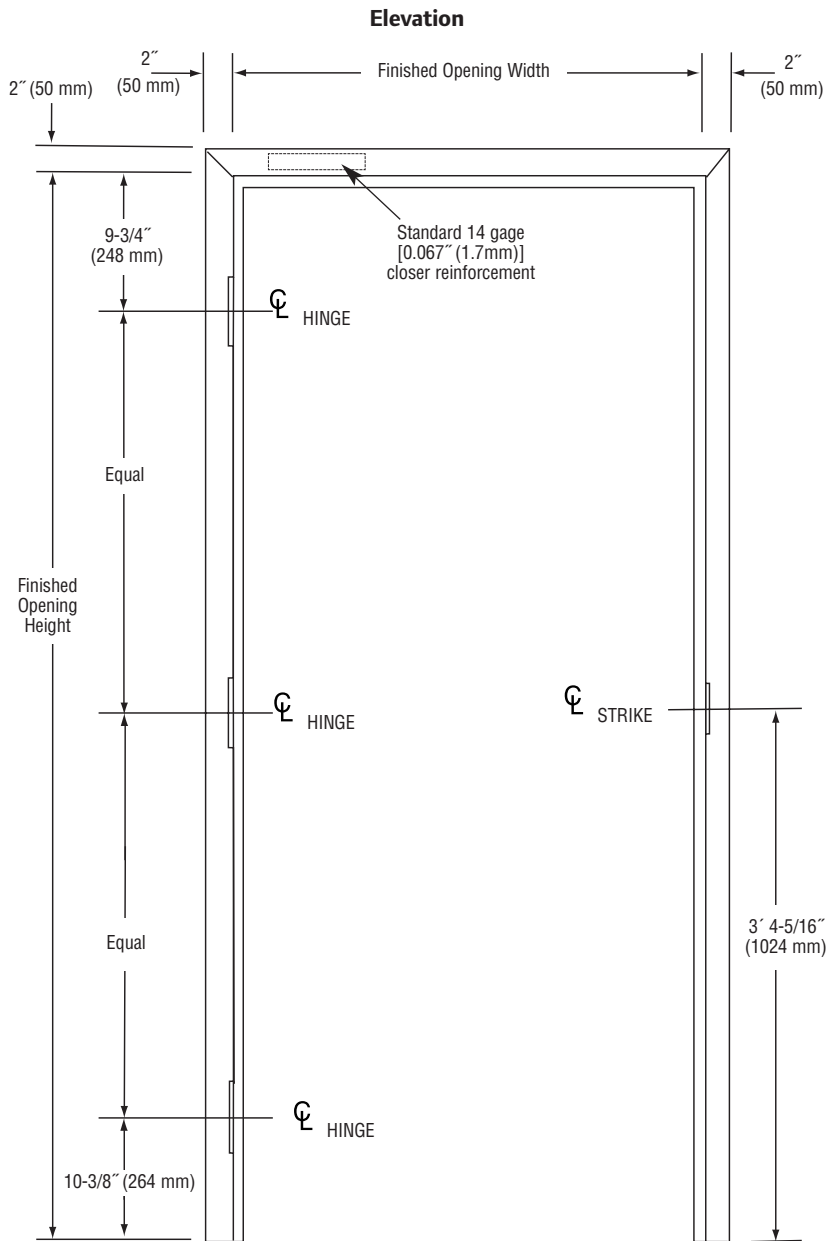

NOTE: FP14 Paladin™ Series Frame are available as double rabbet only.

Frame Sizing Options

Series	Maximum Opening Size		Jamb Depth Availability (Profile)				Standard Profile Dimensions (Variations Available)			Corners Standard
	Single	Pair	Single Rabbet		Double Rabbet		Face	Stop	Returns	
			Min	Max	Min	Max				
FP14	4'-0" X 9'-0" (1219mm X 3150mm)	8'-0" X 9'-0" (2438mm X 3150mm)	n/a		5 3/4" (146mm)	10-3/4" (274mm)	2" (51mm)	5/8" (16mm)	1/2" * (13mm)	DIE MITERED with four (4) concealed tabs interlocking head and jambs
										SQUARE CUT for SUA Corner

n/a = not available

* except 5-3/4" (146mm) depth, which is 7/16" (11mm)

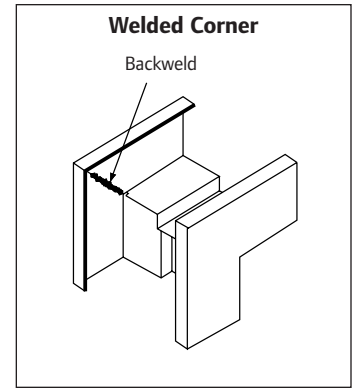
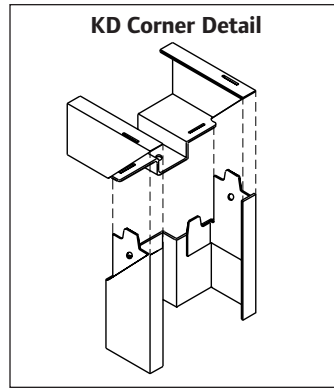
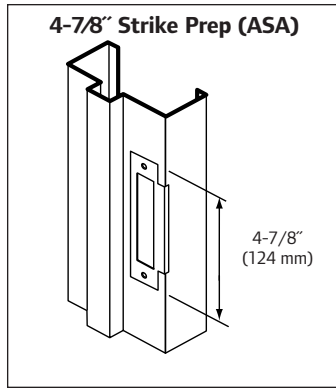
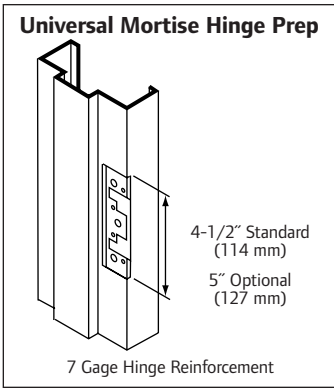

GENERAL NOTES:

1. Variations in jamb depths available in 1/8" (3mm) increments.
2. All FP Paladin™ Series Frames are supplied standard with masonry wire or lock-in jamb anchors and adjustable base anchors. Anchors are designed for maximum wall/frame engagement and installation flexibility.
3. FP Paladin Series Frames are to be installed as part of the framing sequence.
4. All frames are supplied with a factory applied baked-on primer for ultimate field paint adhesion.
5. Steelcraft provides Galvannealed steel for both interior and exterior applications.

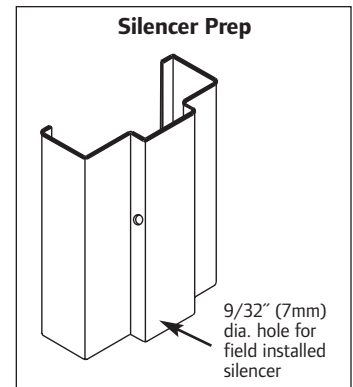
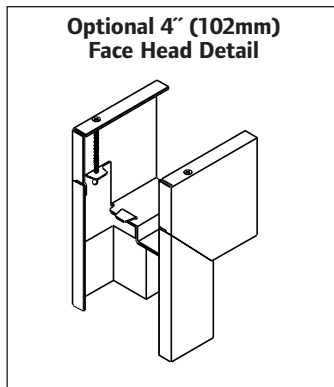

Frame Options

Series	Frame Profile		Corner Connections				4" (182mm) Heads
			HD (Knock-Down)		SUA (Up and Welded)		
	Single Rabbet	Double Rabbet	Single Rabbet	Double Rabbet	Single Rabbet	Double Rabbet	
FP14	n/a	Typically for walls 4-3/4" (121mm) thick or greater	n/a	4 tabs per factory die-miter	n/a	Available when specified, and in accordance with ANSI A250.8-2003 (SDI 100).	Die-mitered for use with 2" (51mm) face double rabbet jambs. Available when specified for KD or SUA applications.

ANCHORING SYSTEMS

See Anchoring Systems Sections in this manual for:

- Wire Masonry Anchors
- Existing Wall Anchors
- Adjustable Base Anchors

Removable Mullion for use with 3-Point Exit Device or Multi-Point Deadlock

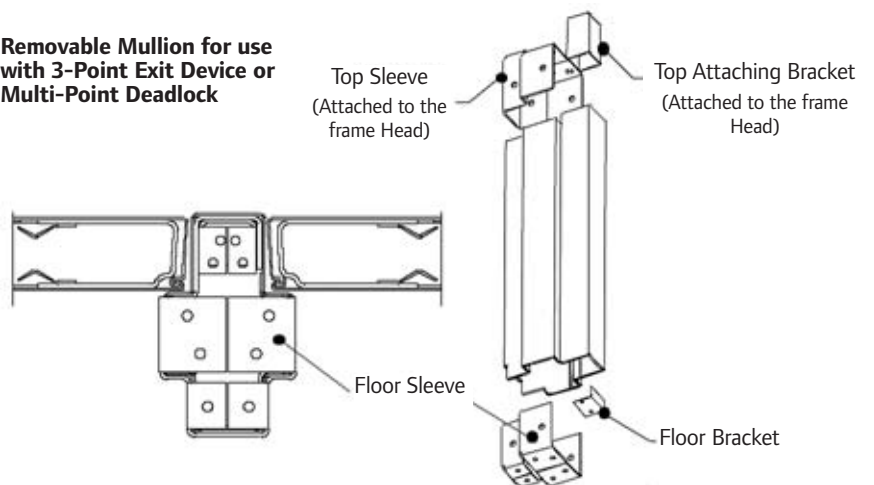

FRAMING APPLICATIONS

Series	Steel Type	Building Type	Opening	KD ¹ Corner	SUA Corner	Applications
FP14	Non-Galvanneal Galvannealed	Institutional and Commercial	Mainly Interior Exterior if Specified	X	X	Tornado Shelters in accordance with FEMA 361 or Safe Room

UL OPENINGS WITH VON DUPRIN HARDWARE

The **Paladin™ Series** door system (PW14 series doors and FP14 series frames) are available in compliance with FEMA 361 and ANSI ICC500 with factory attached labels in the configurations shown below.

Single Door Applications:

1. Maximum Door Opening Size = 4' 0" wide X 8' 0" high
2. Hardware is Von Duprin: WS98/99(F)

Double Door Applications:

1. Maximum Door Opening Size = 8' 0" wide X 8' 0" high.
2. Hardware is Von Duprin: WS99/99(F) both leaves

Notes:

1. Steelcraft's Paladin™ Series door system is tested as a complete door frame and hardware system.
 - Door, frame and anchors must be ordered from Steelcraft
 - Exit device hardware must be Von Duprin.
2. When specified, UL fire door labels are factory attached stating listings in accordance with UL10C Fire Resistance Ratings in the configurations shown below:

SINGLE OUT SWING

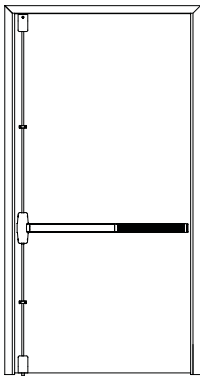

Von Duprin Surface WS98/99(F)
 2 point locking
 4080 Max. - Not fire rated

DOUBLE OUT SWING

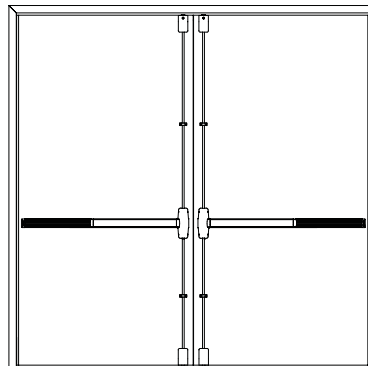

Von Duprin Surface WS98/99(F)
 2 point locking active and inactive
 8080 Max. - 90 minute fire rated

UL OPENINGS WITH SECURITECH HARDWARE

The **Paladin™ Series** door system (PW14 series doors and FP14 series frames) are available in compliance with FEMA 361 and ANSI ICC500 with factory attached labels in the configurations shown below.

Single Door Applications:

1. Maximum Door Opening Size = 4' 0" wide X 9' 0" high
2. Hardware: 5300, 7300 or 8300 series devices

Notes:

1. Steelcraft's Paladin™ Series door system is tested as a complete door frame and hardware system.
 - Door, frame and anchors must be ordered from Steelcraft
 - Exit device hardware must be Securitech, see hardware options below.
2. When specified, UL fire door labels are factory attached stating listings in accordance with UL10C Fire Resistance Ratings in the configurations shown below:

SINGLE IN SWING OR OUT SWING

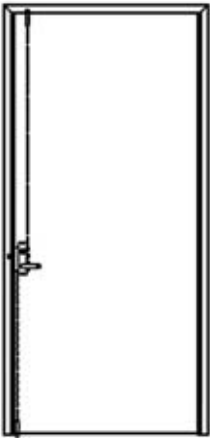

Concealed:
Securitech: #5300 or #7300
3 point locking
Not fire rated

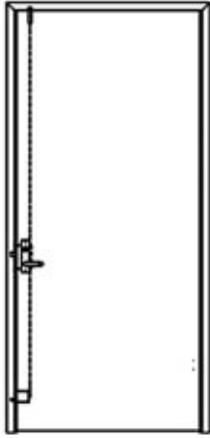

Concealed:
Securitech: #5300 or #7300
3 point locking
Not fire rated

SINGLE OUT SWING

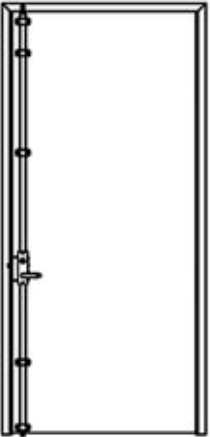

Surface:
Securitech: #5300
3 point locking
Not fire rated

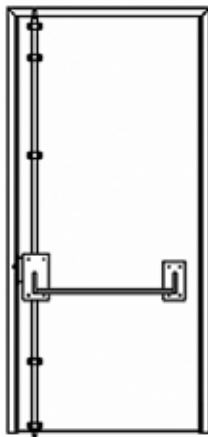

Surface:
Securitech: #8300
3 point locking
Fire: 3 hour - 4080 Max.

SINGLE OUT SWING ONLY

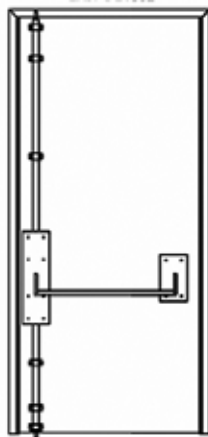

Surface:
Securitech: #8200SH
2 point locking
Not fire rated

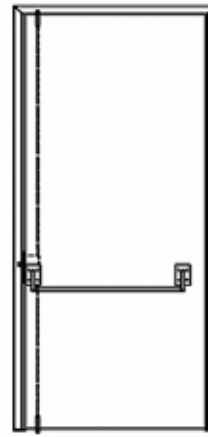

Concealed:
Securitech: #5300 or #7300
with 3 point locking
Not fire rated

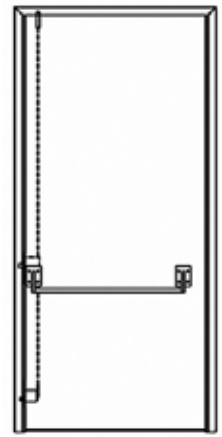

Concealed:
Securitech: #7300
3 point locking
Not fire rated

Securitech: #8300
with 3 point locking
Fire: 3 hour - 4080 Max.

UL OPENINGS WITH SECURITECH HARDWARE

The **Paladin™ Series** door system (PW14 series doors and FP14 series frames) are available in compliance with FEMA 361 and ANSI ICC500 with factory attached labels in the configurations shown below.

Double Door Applications:

1. Maximum Door Opening Size = 8' 0" wide X 9' 0" high.
2. Hardware: 5300, 7300 or 8300 series devices with IVES model # 360 surface bolt.

Notes:

1. Steelcraft's Paladin™ Series door system is tested as a complete door frame and hardware system.
 - Door, frame and anchors must be ordered from Steelcraft
 - Exit device hardware must be Securitech, see hardware options below.
2. When specified, UL fire door labels are factory attached stating listings in accordance with UL10C Fire Resistance Ratings in the configurations shown below:

DOUBLE OUT SWING – 3 point locks with astragal

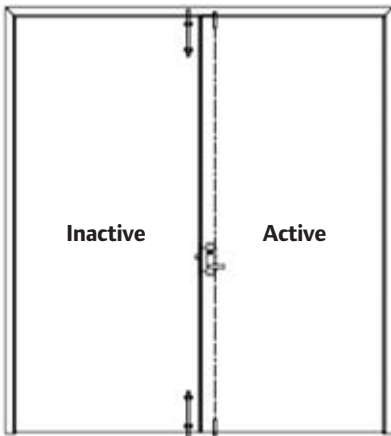

Concealed:

Active - Securitech # 5300, 7300 or 8300
 3 point locking
 Inactive – Ives # SB360
 Not fire rated

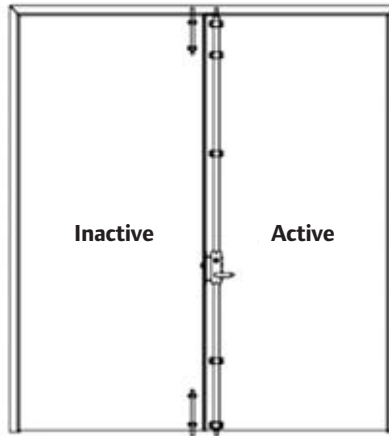

Surface:

Active - Securitech # 5300, or 8300
 3 point locking
 Inactive – Ives # SB360
 Not fire rated

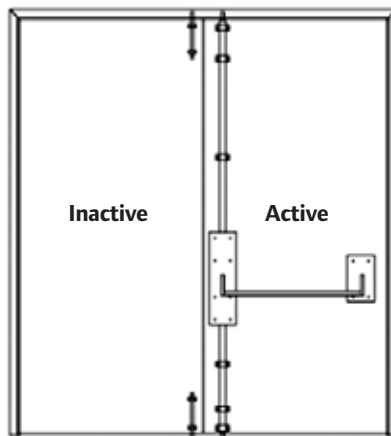

Surface

Active - Securitech # 8200
 2 point locking
 Inactive – Ives # SB360
 Not fire rated

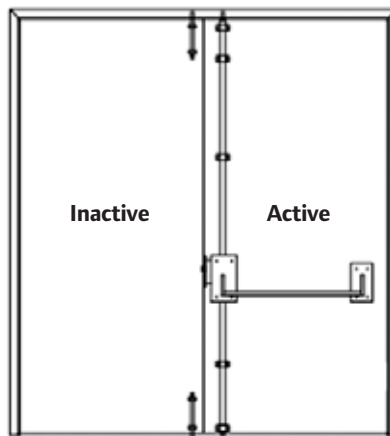

Surface

Active - Securitech # 8300
 2 point locking
 Inactive – Ives # SB360
Fire Rated: 3 hour - 8080 Max

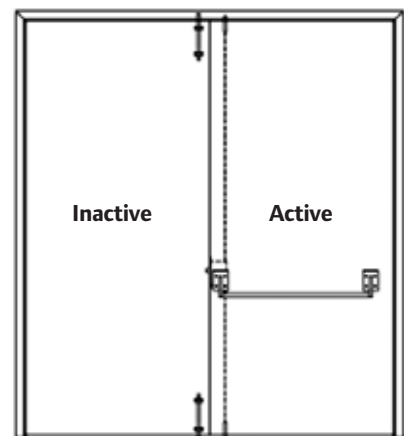

Concealed

Active - Securitech # 7300 or 8300
 3 point locking
 Inactive – Ives # SB360
Fire Rated: 3 hour - 8080 Max

UL OPENINGS WITH SECURITECH HARDWARE

The **Paladin™ Series** door system (PW14 series doors and FP14 series frames) are available in compliance with FEMA 361 and ANSI ICC500 with factory attached labels in the configurations shown below.

Double Door Applications:

1. Maximum Door Opening Size = 8' 0" wide X 9' 0" high.
2. Hardware: 5300, 7300 or 8300 series devices with IVES model # 360 surface bolt.

Notes:

1. Steelcraft's Paladin™ Series door system is tested as a complete door frame and hardware system.
 - Door, frame and anchors must be ordered from Steelcraft
 - Exit device hardware must be Securitech, see hardware options below.
2. When specified, UL fire door labels are factory attached stating listings in accordance with UL10C Fire Resistance Ratings in the configurations shown below:

DOUBLE OUT SWING – With center mullion

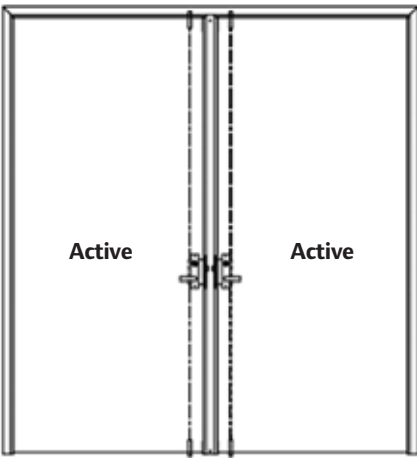

Concealed

Active & inactive:
Securitech # 7300 or 8300
3 point locking
Not fire rated

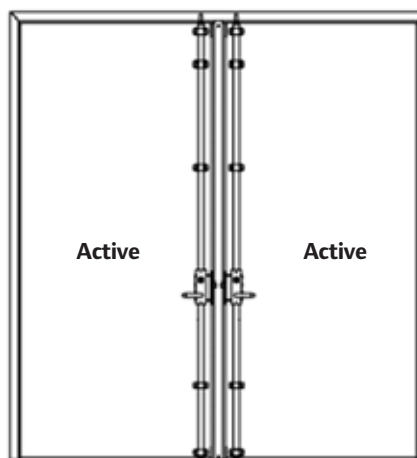

Surface

Active & inactive:
Securitech # 7300 or 8300
3 point locking
Fire Rated: 1 1/2 hour - 8080 Max

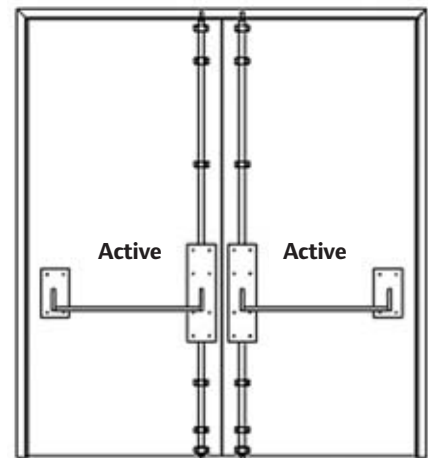

Surface

Active - Securitech # 8200SH
2 point locking
Inactive - Ives # SB360
Fire Rated: 1 1/2 hour - 8080 Max