

Phantom Screens:

There When You Need Us



PHANTOM
Door Screens



EXECUTIVE
Power Screens



SERENE
Window Screens



PHANTOM®
SCREENS

Canada - P.O. Box 2310
Abbotsford, BC V2T 4X2
USA - P.O. Box 1907
Sumas, WA 98295 -1907

Tel: 604-855-3654
Fax: 604-855-7834

Toll Free: 1-888-444-4142

phantom@phantomscreens.com
www.phantomscreens.com

Innovative Solutions for All Your Screening Needs

Message from the CEO:

As an architect, builder, designer, or a discerning homeowner, you know how important it is to preserve the integrity of a building's design. The creation of a beautiful structure should not be compromised. Yet practical considerations often conflict with visual ideas.

Phantom Screens® was founded to provide a better alternative to conventional door and window screens. Since its beginning 16 years ago, we have offered innovative screening solutions and superior customer service. Phantom's screens merge vision and functionality to fully reveal beautiful exterior views. Having grown to become North America's leading provider of retractable screening solutions for residential and commercial sectors, Phantom products bring a new level of form and function to doors, windows, and oversized openings such as verandas and lanais.

Everyone at Phantom is passionate about achieving excellence in product quality and client services. The level of satisfaction we continue to earn with our customers in the marketplace dictates our future success and opportunities. According to independent market research, 97% of our customers rate their overall Phantom experience from good to outstanding.

Upholding truthfulness, serving one another, pursuing excellence, and practicing stewardship and corporate responsibility form the core values of Phantom Screens.

Staying true to these values has created the key point of differentiation of Phantom Screens in the marketplace. Our commitment to you is grounded in our tradition and goes to the very heart of what we do and how we do it. Our customers and partners deserve nothing less.

Sincerely,



C. Esther DeWolde, CEO
Phantom Mfg. (Int'l) Ltd.

Our Vision

There when you need us, enhancing your lifestyle, making us your choice for retractable screening solutions ...experience Phantom.



PHANTOM®
S C R E E N S

Complete Solutions

Phantom's screens truly meet the demands of today's sophisticated designers, builders, and homeowners. With over 16 years of industry experience, hundreds of thousands of installations across North America, and on-going customer feedback, we understand what people want and expect in a retractable screening solution. Unlike conventional insect screens, Phantom's screens don't obstruct the view, because they are there when needed and out-of-sight when not in use.

As a leading provider of retractable screens, Phantom provides innovative screening solutions for all types of door, window, oversized, and custom applications. Phantom's retractable screening solutions are suitable for both residential and commercial structures—custom homes, condominiums, hotels & resorts, restaurants, retail stores, universities, and other project types.

It is important for Phantom Screens to work closely with architect and builder communities in order to ensure total integration of Phantom products to the design of the buildings. Phantom Screens has developed a series of services for the specifier communities, providing information on our product specification details, 3-D CAD drawings, and product installation services.

Phantom Screens is a Registered Provider with the American Institute of Architects (AIA) Continuing Education System (CES), and a member of the National Council of the Housing Industry (NCHI), and the National Association of Home Builders (NAHB).

You can contact Phantom's Specifications Sales Manager by calling 1-888-444-4142, or access our product information at <http://business.phantomscreens.com/technical.html>.

Parallel top and bottom tracks hold the screen in place

The sturdy slidebar guides the screen across

When not in use the screen retracts back into the low-profile housing





Discover the Possibilities with the Phantom Door Screen Solution

PHANTOM®
SCREENS

Phantom Door Applications

While our first product—the retractable Phantom door screen—has been modified and improved significantly since its original roll-out in 1992, it continues to set industry standards. There when needed, the Phantom Screen retracts safely away in its protective housing when not in use.

Phantom's screens can be used in any setting; their innovative design and tasteful styling fit with any room you choose. Perfect for sliding, in-swing, out-swing, and especially double-French doors, the retractable Phantom door screen pulls into place when needed, and retracts out-of-sight when not in use.

Features and Benefits

- Remains out-of-sight until needed
- Offers the most effective and attractive screening solution for doors
- Allows full ventilation, providing protection from insects and UV rays
- Combines innovative, consumer-driven design and styling
- Ensures years of trouble-free operation with long-lasting durability
- Blends with existing door frames with its low profile housing
- Holds screens tightly in place with its spring tension technology
- Absorbs impact without sagging or tearing
- Available with a roll control option
- Adapts to in-swing & out-swing doors, as well as various thresholds and sizes
- Comes in a variety of popular designer colors and wood grain finishes
- Guarantees additional peace of mind with the Limited Lifetime Warranty
- Delivers superior quality with an installation by experienced service professionals.

Please see our design specifications on Page 6 for detailed technical information.



Sliding Door



Oversized Double Opening



Double French Door



Single Out-swing Door



Single In-swing Door



Front Door

Executive Oversized Power Screens



The Versatile Power Screen Solution

Executive Screen Applications

The Executive Screen is the perfect addition to any custom renovation project or new building design. Ideal for both commercial and residential construction projects, the Executive Screen covers all large application types, including verandas, covered patios, lanais, picture windows, and garage doors.

Screening and Shading Options

The Executive Screen has a variety of screening and shading options to enhance the unique features of any building:

- Insect: Reduces up to 55% of UV rays and keeps insects out
- Solar: Blocks the sun's heat and glare by up to 75% while keeping insects out
- Premium Solar: Offers substantial shading and reduces fading by blocking up to 80% of UV rays
- Pet Friendly: Resists damage by dogs and cats while providing excellent visibility and up to 55% UV protection
- Privacy: Provides up to 100% blockage of UV rays.

Features and Benefits

- Retracts out-of-sight when not in use
- Supplies enhanced privacy
- Includes a pet resistant screen option
- Allows full ventilation, providing protection from insects and UV rays
- Comes in a variety of popular designer colors and wood grain finishes
- Fits most oversized applications
- Includes a power feature with optional wall-control or remote-control that can be linked to the home automation system
- Enables recessing of the screen housing and tracks into walls, ceiling cavities, and columns to create a fully retracted screening solution
- Offers an optional manual retraction system
- Ensures years of trouble-free operation
- Comes in sturdy aluminum extruded housing, equipped with brush pile seal
- Delivers superior quality with the installation by experienced professionals
- Guarantees additional peace of mind with the Limited Lifetime Warranty.

Top: Veranda with Insect Screen

Above: Garage Door with Insect Screen

Right: Garage Door with Solar Screen



Please see our design specifications on Page 6 for detailed technical information.



Top: Balcony

Bottom: Porch

Roman Archway

Top: Gallery

Bottom: Lanai

Picture Window Open

Picture Window Closed



The Picture Perfect Window Screen Solution

Serene Window Screen Applications

Offering total protection from insects while maintaining the views from inside and out, the Serene window screen is a unique addition to any construction or renovation project. The retractable Serene window screen is stylish and adaptable, complementing any window application. It provides a better view to the outside, blocks insects and UV rays, and improves the look of the window itself when not in use.

Fit for any room you choose, the Serene Screen is a perfect blend of form and function. It is adaptable to casement and awning, single and double-hung, tilt'n'turn, sliding and various specialty window applications. Only there when needed, it retracts out-of-sight when not in use.

Features and Benefits

- Retracts out-of-sight when not in use
- Offers the most effective and attractive screening solution for windows
- Enables interior and exterior mount and recessed installation options
- Allows full ventilation, providing protection from insects and UV rays
- Combines innovative, consumer-driven design and styling
- Ensures years of trouble-free operation and durability
- Blends with existing window frames with its low profile housing
- Holds screens tightly in place with its mesh retention system
- Absorbs impact without sagging or tearing
- Adapts to most window applications and sizes
- Comes in a variety of popular, designer colors and finishes, including wood grain
- Delivers superior quality with the installation by experienced professionals
- Guarantees additional peace of mind with the Limited Lifetime Warranty.

Please see our design specifications on Page 6 for detailed technical information.



Double-Hung Window



Single-Hung Window



Casement Window

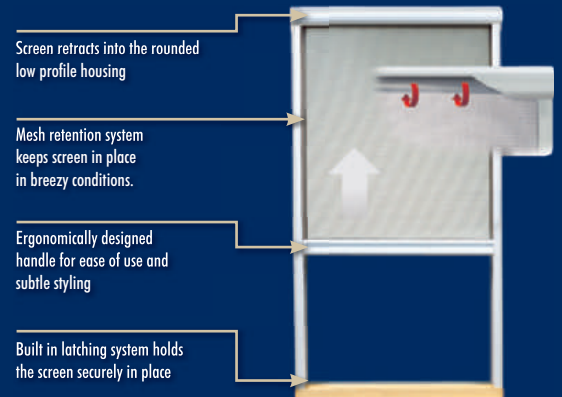

Design Specifications

Screens That Fit Your Needs

Phantom's retractable screens are available in a variety of sizes to fit virtually any application. Please refer to the color-coded chart below for our products' maximum and minimum dimensions.

Screen Sizes

Screen	Style	Height/Width	Pull Length
Phantom	Single Door (one screen unit)	78" to 100" h 100 1/8" to 120" h	Max 48" Max 36"
	Double Door (two screen units)	78" to 100" h 100 1/8" to 120" h	Max 96" Max 72"
Executive	Oversized I	34" to 20' w	Max 11'
	Oversized II	20' 1/8" to 25' w	Max 16'
Manual Executive	Oversized I	24" to 19' w*	Max 11'*
Serene	Window I	13 1/2" to 16 7/8" w*	Max 48"**
	Window II	17" to 72" w*	Max 78"**

*Not all mesh types are available in sizes offered.

Custom Finishes to Match Perfectly

Phantom's family of screens come in a variety of Signature designer colors, as shown below, to match most exterior or interior finishes. All of Phantom's retractable screens are also available in virtually any color including a variety of Decoral® decorative wood grain finishes.

Standard Colors*

	Classic White	Slivered Almond	Sandal Wood	Driftwood Beige	Hartford Green	Rideau Brown	Coastal Gray	Bronze	Phantom Black
Phantom	●	●	●	●	●	●	●	●	●
Executive	●	●	●	●	●	●	●	●	●
Serene	●	●	●	●	●	●	●	●	●

*While every effort has been made to reproduce the actual color of the product, variations may occur in brochure production/printing. These color samples are to be used as a general color guide only.

The Finest Components

- Slidebar, housing and tracks are made from high-quality extruded aluminum
- Powder coated finish resists fading and chipping*
- Sturdy, UV resistant nylon handle and fittings (Phantom and Serene only)
- Fiberglass mesh ensures enhanced durability (various mesh options for insect, solar and privacy are available)
- Color-matched corrosion resistant screws
- Sturdy spring mechanism retracts screen (Phantom and Serene only)
- Built-in latching mechanism holds screen in place (Serene only)
- Wind and sun control options available (Executive only)
- Mesh retention system (Serene only).

* Depending on the availability of the selected color tone, the housing and frames will be provided in either powder-coated or wet coat finishes.

Phantom Parts Specs

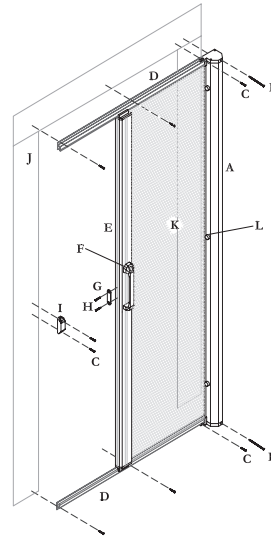

- A. Assembled Aluminum Housing c/w Nylon End Caps
- B. Flathead Screw (color matched)
- C. Panhead Screw (color matched)
- D. Aluminum Track
- E. Assembled Aluminum Slide Bar c/w Nylon End Caps
- F. Nylon Handle
- G. Corrosion Resistant Steel Magnet Strike Plate
- H. Flathead Screw (unfinished)
- I. Nylon Magnet Housing c/w Magnet Assy
- J. Mounting Surface
- K. PVC Coated Fiberglass Mesh
- L. Bumpons- Clear Vinyl- Medium

All components are color matched except mesh and bottom seal.

All fasteners are corrosion resistant. Type and length of fasteners may vary depending on type of mounting surface.

Executive Parts Specs

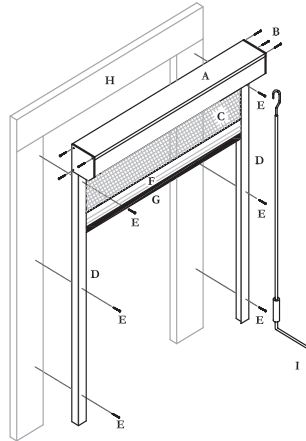

- A. Housing Assembly 5-1/2"W x 5-1/2"H or 7-1/8"W x 7-1/8"H
- B. Corrosion Resistant Fastener (Color Matched) 3 Fasteners per End Cap
- C. PVC Coated Fiberglass Mesh or other- see Mesh Specifications
- D. Standard Side Track c/w Cover
- E. Panhead Screw (color matched)
- F. Slide Bar c/w Probe Assembly
- G. Bottom Seal- 4" Shown (Other Option Available)
- H. Mounting Surface
- I. Manual Handle Option

Executive applications for recessed and manual systems are available. All components are color matched except mesh and bottom seal. All fasteners are corrosion resistant. Type and length of fasteners may vary depending on type of mounting surface.

Serene Parts Specs

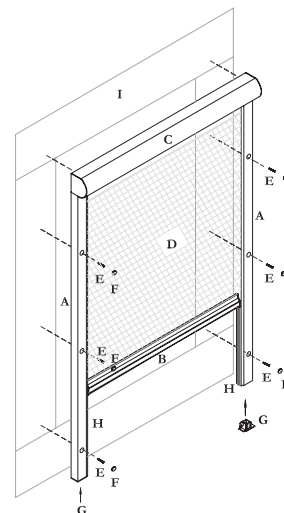

- A. Aluminum Track
- B. Aluminum Slide Bar
- C. Aluminum Housing Assembly
- D. PVC Coated Fiberglass Mesh
- E. Flathead Screw (unfinished)
- F. Track Screw Hole Cover
- G. Track Latch
- H. Mesh Retention Pile- Inside Full Track Length (Both Sides)
- I. Mounting Surface

All components are color matched except mesh and bottom seal. All fasteners are corrosion resistant.

Type and length of fasteners may vary depending on type of mounting surface.

To obtain complete architectural specifications, go to <http://business.phantomcreens.com/technical.html> or contact us at 1-888-444-4142

The #1 Retractable Screening Company

Since its foundation, Phantom Mfg. (Int'l) Ltd. has continued to lead and revolutionize the retractable screening industry. With a 45,000 sq. ft. manufacturing facility, experienced corporate leadership, and a North America-wide distribution network, the Phantom brand is synonymous with quality, innovative product development and superior customer service.



The ultimate goal of Phantom Mfg. (Int'l) Ltd. is to achieve complete customer satisfaction. Our trained service professionals and the Limited Lifetime Warranty ensure that all Phantom's customers receive years of use and enjoyment from every screen purchased. In short, Phantom's vision of excellence is your assurance of quality.



A Customer-focused Approach

Our entire focus has been—and continues to be—on providing innovative retractable screening solutions, not just retractable screens. We have earned our market leadership position with this customer focused approach. According to independent market research, 97% of our customers recognize the value delivered by our brand, rating their overall Phantom experience from good to outstanding. From offering quality products and services, to our commitment to being there when you need us, we aim to enhance the quality and value of every renovation and construction project.





Delivering value
inspiring confidence

Stylish

Versatile

Functional

Adaptable

Visually pleasing

Designed and
crafted with quality

Infinite possibilities



Canada - P.O. Box 2310
Abbotsford, BC V2T 4X2

USA - P.O. Box 1907
Sumas, WA 98295 -1907

Tel: 604-855-3654
Fax: 604-855-7834

Toll Free: 1-888-444-4142

phantom@phantomscreens.com
www.phantomscreens.com



We're Here to Serve You

Please call 1-888-PHANTOM
to contact a distributor near you!

see us at
Sweets.com



PHANTOM®
SCREENS