

C. Sherman Johnson Co., Inc.
Johnson
Architectural Hardware



www.csjohnson.com



INCLUDES...
Full 65 page
MARINE
CATALOG
Flip to Back



Johnson Architectural Hardware

Over 55 Years of proven performance in the demanding marine environment...

C. Sherman Johnson Company Incorporated has been designing, developing and manufacturing stainless steel hardware since 1958. For over 55 years Johnson Marine has been the marine industries #1 leader in lifeline fittings. Those same quality products are used to create cable railing systems for a variety of projects in residential, commercial, retail, theme parks, medical, industrial and military applications. You will notice from the following fabricator supplied photos that Johnson Architectural works closely with local fabricators around the country. This allows us to provide a level of service and custom design to the end user that that is unmatched by other cookie cutter railing systems. If you want a quality Made in USA cable railing with hardware to fit every style look no further then Johnson Architectural. Let our catalog walk you through the steps to a beautiful functional cable railing system and design one for yourself today.

Information



Yale Building Project 2014 - Yale School of Architecture New Haven, CT

Johnson Architectural was asked again by the Yale School of Architecture to participate in the Jim Vlock Building Project for 2014. Each year Yale Architectural students design and construct a building for a community based client. Johnson Architectural was pleased to have supplied the cable fittings and cable for the project.



Cover Photo: Private Residence - Cardiff by the Sea, CA
Cable Fabricator: San Diego Cable Railings - San Diego, CA



Private Home - Westport, CT
Cable Fabricator: Nature's View Railing - Waterford, CT



Private Residence - Cardiff by the Sea, CA
Cable Fabricator: San Diego Cable Railings - San Diego, CA



MOZ - Seattle, WA
Fabricator: Cook Welding Services - Everett, WA



University of Tennessee at Chattanooga
Fabricator: Al-Co Fabrications Inc. - Rossville, GA



Private Home - Galveston, TX
Cable Fabricator: Bahama Rigging - Kemah, TX



Private Home - Sarasota, FL
Fabricator: Brubachers, LLC - Sarasota, FL

Got photos of your cable rail installation? Let us feature you in our next catalog! Email your hi-res photos to info@csjohnson.com. Be sure to include the location, rigger/contractor and a short description.

Photos not to be reproduced without the expressed written consent of C. Sherman Johnson Co., Inc.



Private Home - Celso, NC
Cable Fabricator: Charleston's Rigging & Marine Inc.
Charleston, SC



Private Home - Old Lyme, CT
Cable Fabricator: OCD Rigging - Chester, CT



Google Campus - Mountain View, CA
Fabricator: Duvall Design Inc. - West Rockport, ME



Private Home - Okoboji, IA
Fabricator: Alger Customs - Milford, IA



Private Home - Tacoma, WA
Cable Fabricator: American Metal Specialties - Tacoma, WA



Getting started is easy...

Thank you for considering Johnson Architectural Hardware for your next cable project. Please review the following informational pages and see how easy it is to specify and select cable components that will enhance and beautify your next project.

How the Cable Attaches

Machine Swage Terminal



Machine Swage (swāj): Fittings are attached to the cable by means of a cold forming press. The completed fitting has a smooth uniform appearance and will develop full cable strength. Swaging services can be performed by professional riggers and sling manufacturers.

Hand Crimp Terminal



Hand Crimp: Hand Crimp is available in 1/8" & 3/16" cable only. Fittings are attached to the cable using a simple hand tool (allows field installation). The completed fitting will provide approximately 65-70% of the 7x7 cable strength. We can provide the necessary tool.

Mechanical Terminal



Mechanical: Fittings are available for all cable sizes and are attached with simple hand tools. Mechanical fittings are more expensive than other means of attachment but develop full cable strength.

Smooth Line Turnbuckle-Cable Attachment

Smooth Lines have no exposed threads and the cable is fastened internally by a sleeve on the back side of the cap.

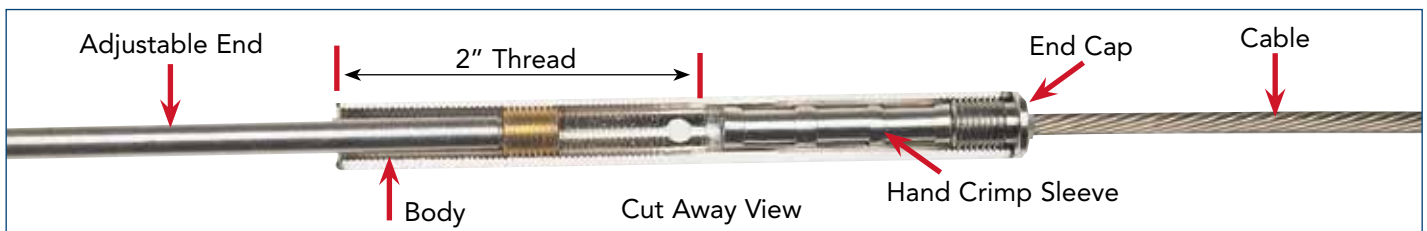

Terminator Turnbuckle - Cable Attachment

The Terminator uses coarse thread for use with the supplied screw or with a coarse screw of your choice.

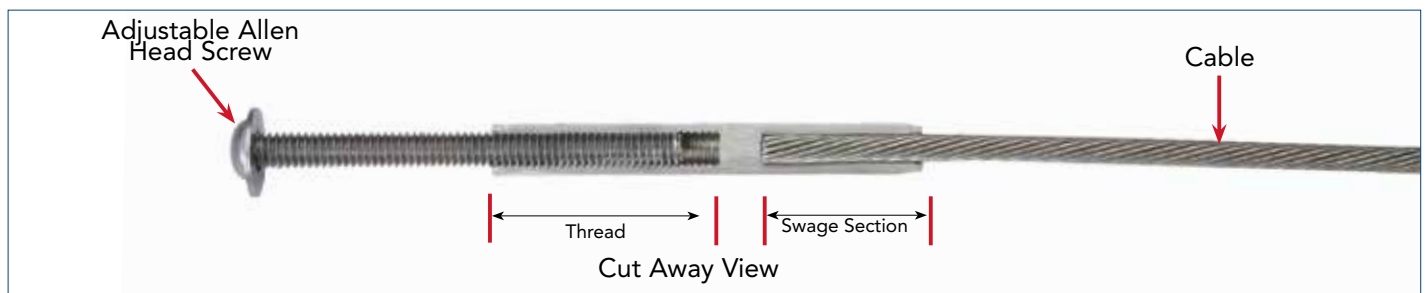



Information & Specifications

Cable Set Up:

- Space cable at 3 inches on center to meet a 4 inch code or 1 inch closer than the code requires.
- End posts need to be strong enough to support the number of cable assemblies used and tensioned to 350 lbs. per cable assembly.
- Intermediate posts need to be placed every 4 feet.
- Cable lengths need to be kept under 50 feet in length for conventional turnbuckles and up to 25 feet for Smooth Line and Terminator fittings.

End Attachment Specifications:

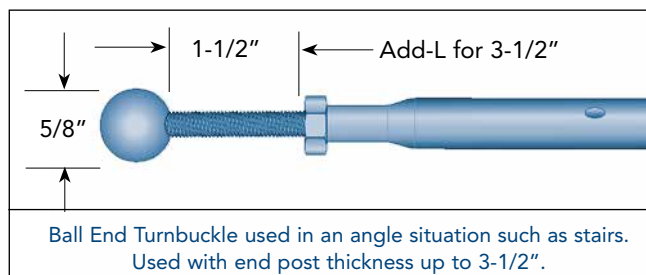
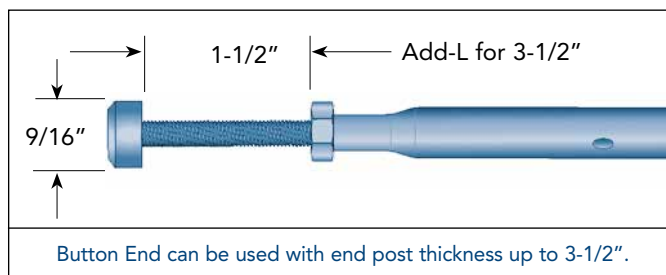
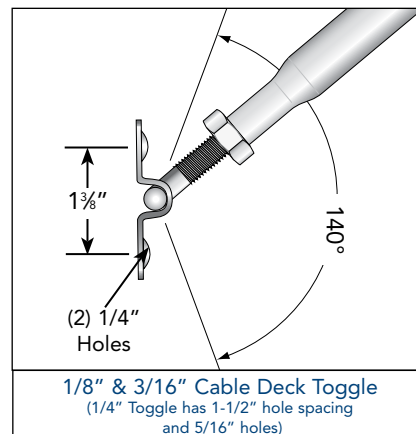
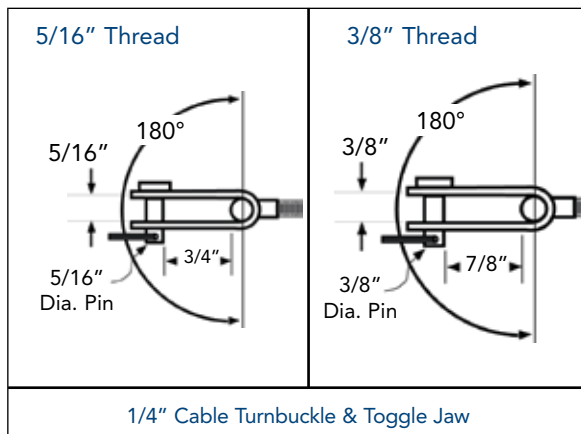
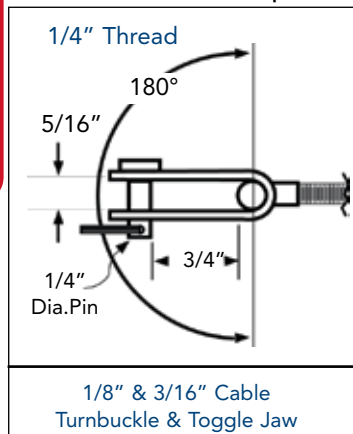

Cable

Cable Selection

Generally 1/8", 3/16", or 1/4", 1x19 stainless steel cable is chosen for most railing applications. 3/16" cable is the most popular size for general applications. 1/4" cable is for high traffic applications.

Description of Wire Construction:

- 1 x 19 - Semi-rigid...used for straight runs
- 7 x 7 - Semi-flexible...used for short runs and decorative corners
- 7 x 19 - Flexible...used for decorative purposes

Stainless Steel Wire Rope Breaking Strength

DIA.	1x19	7x7	7x19
1/8"	2100	1700	1760
3/16"	4700	3700	3760
1/4"	8200	6100	6400
3/8"	17500	12600	12000

Cable Assemblies

A complete cable assembly must have the following elements: 1) A turnbuckle or an adjustable threaded terminal to tension the cable, 2) An attachment point at each end, with an end fitting, that will support the tension of the cable. Unless you have these two elements, you do not have a proper cable assembly. There are many different ways to make a cable assembly. Aesthetics are very important so we provide a variety of fittings that do the same thing but have a different appearance. You can design your rail and mix & match to come up with just the look you want. Johnson Architectural does not make cable assemblies, but we can set you up with a cable fabricator in your area to provide for your needs. For Hand Crimp fittings, wire and the proper tool to make your own cable assemblies, call Johnson.



Suggested Railing Framework

Information

Basic Framework

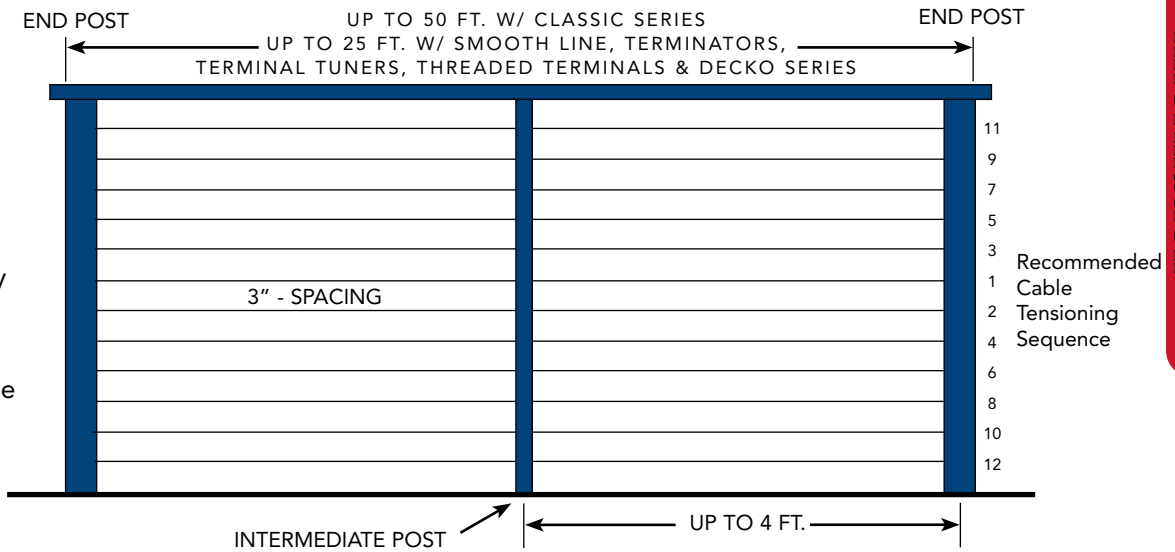

The following is only a guide line. Please check your local building code for use of cable rails.

Framework:

End posts and corners need to be made from the following minimums:

- Round Pipe 1-1/2" ID Schedule 80
- Square Tube 2" X 2" X 1/4" Wall
- Angle Iron 2" X 2" X 1/2"
- Flat Bar 2" X 1" (widest dimension should be inline with cable tension)
- Wood Post 6" X 6"

Please Note: Johnson Architectural Hardware does not make framework. Framework needs to be made by a steel fabricator.

Technical Support - Call 1.800.874.7455

OK, you want cable railings, but you do not have time to read the catalog. Please call us toll-free at 1.800.874.7455. Johnson Architectural will talk you through the process and make sure you get the help you need.

If you are a contractor or steel fabricator, call us to walk you through the HAND CRIMP cable process. If you are a licensed contractor or steel fabricator, Johnson Architectural can sell you HAND CRIMP hardware direct.

MACHINE SWAGE fittings are only sold to authorized riggers with Mil-Spec swage equipment. If you need machine swage CABLE ASSEMBLIES, please call us for the name and number of a rigger near you.

Good luck with your cable project.





Cable Assembly Examples

Information

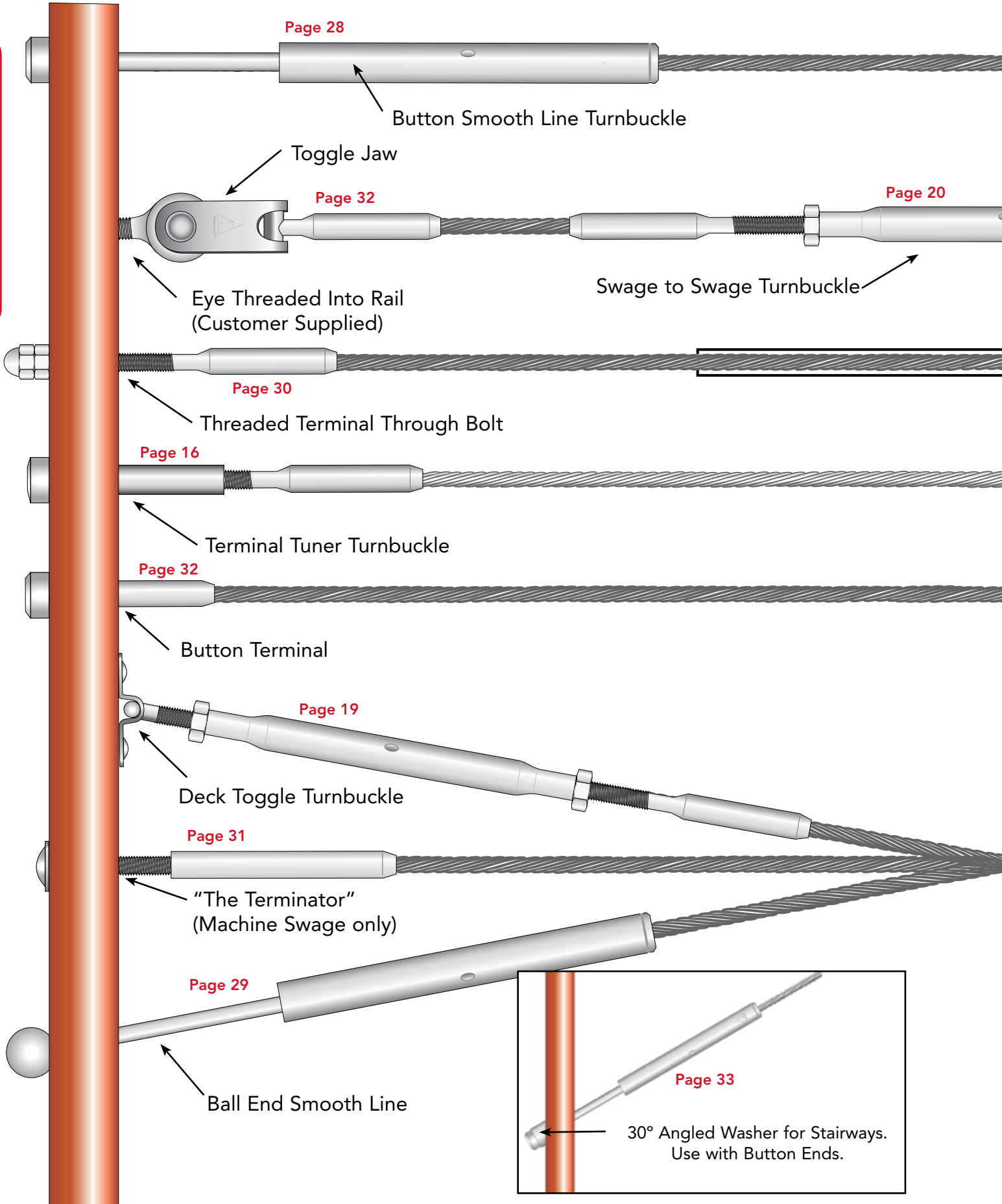



For more information please turn to page....

Information

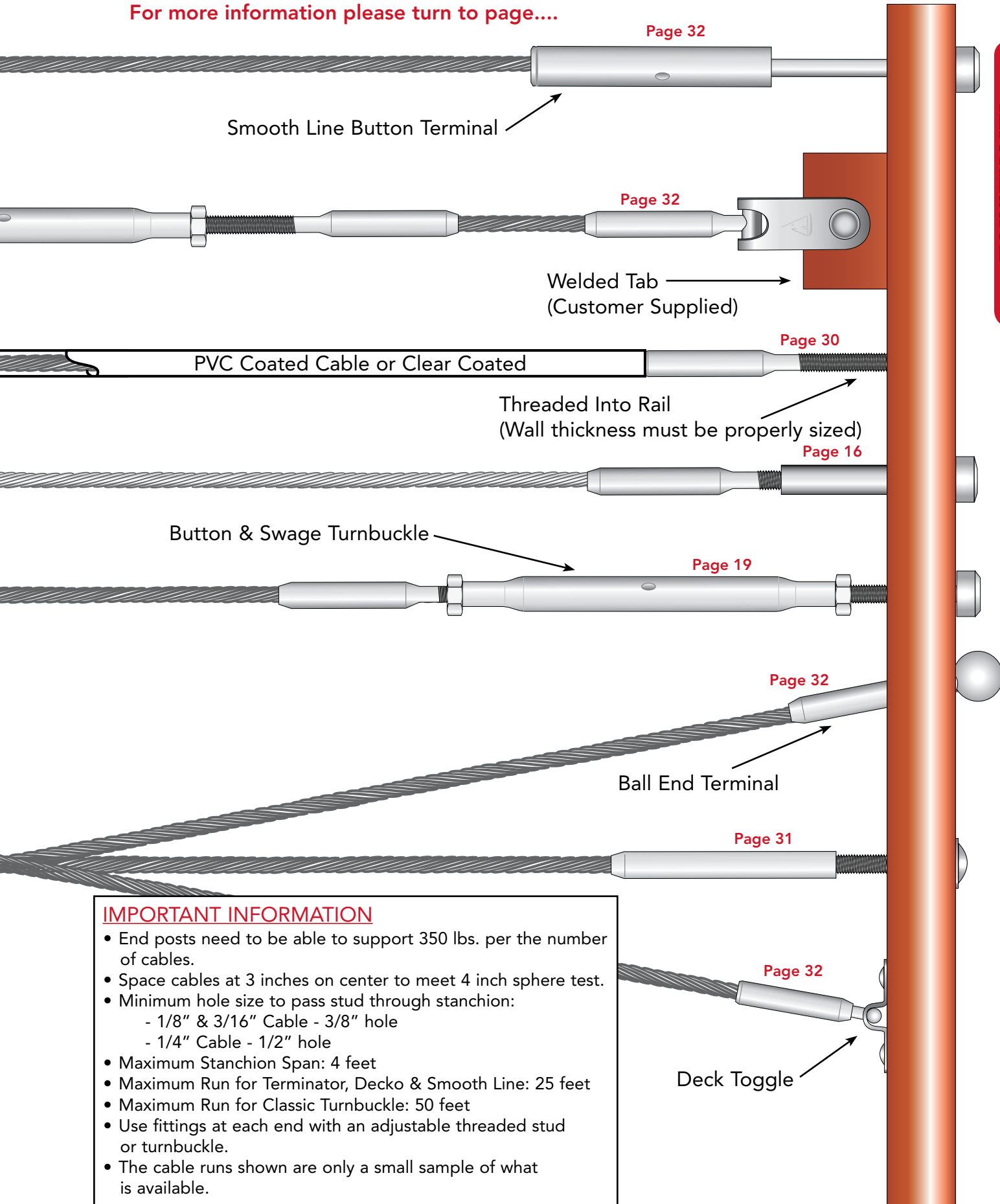

IMPORTANT INFORMATION

- End posts need to be able to support 350 lbs. per the number of cables.
- Space cables at 3 inches on center to meet 4 inch sphere test.
- Minimum hole size to pass stud through stanchion:
 - 1/8" & 3/16" Cable - 3/8" hole
 - 1/4" Cable - 1/2" hole
- Maximum Stanchion Span: 4 feet
- Maximum Run for Terminator, Decko & Smooth Line: 25 feet
- Maximum Run for Classic Turnbuckle: 50 feet
- Use fittings at each end with an adjustable threaded stud or turnbuckle.
- The cable runs shown are only a small sample of what is available.



Frequently Asked Questions

Cable has become an excellent railing material because of Johnson Architectural Hardware. When the natural beauty surrounding a home or building is too precious to block with an ordinary railing, Johnson's cable railings are the answer. Johnson Architectural Hardware cable railings create an unblocked view and satisfies code. Cable will take any path you make for it but there are some rules to follow in order to satisfy code for railings. The following are answers to frequently asked questions:

Q: What is a Turnbuckle?

A: A turnbuckle is a metal coupling device consisting of right and left hand threaded members screwed into an internally threaded body which when rotated expands or contracts.



Q: What is a Machine Swage Fitting?

A: A machine swage fitting is attached to the cable by a swage machine which cold forms the fitting directly to the cable. A swage fitting should not be confused with Hand Crimp fittings or other hand tool applied fittings. A specialized swaging machine is the only way to attach swage fittings to cable. Swage fittings can not be Hand Crimped, welded, glued, hammered or attached to a cable by any other means other than a swage machine.



Q: What is a Hand Crimp Fitting?

A: Hand Crimp fittings were first designed and manufactured by C. Sherman Johnson Co., Inc. in 1969. Hand Crimp fittings are attached to the cable with a Johnson-made Hand Crimp Tool model #53-210 or #53-215. The only other tool that can be used is the National Telephone Supply Co. #64-CGMP. Hand Crimp fittings should not be confused with Nicopress fittings. Nicopress fittings have sleeves that are made from soft copper alloy and compress very easily. All Johnson Hand Crimp fittings are made from stainless steel and can not be swaged, welded, glued, pressed in a vise or with vise grips or attached to the cable by any means other than the Johnson tool #53-210, #53-215 or NTS Co. #64-CGMP.





Q: What is a Mechanical Fitting?

A: A mechanical fitting is attached to the cable by the fitting compressing the cable with a cone inside the fitting and or the cable. Mechanical fittings are assembled to the cable with simple hand tools. Mechanical fittings are larger in diameter than Swage and Hand Crimp fittings and can be reused with a new cone but carry a hefty price tag.



Q: What type of cable do I use?

A: Generally 1x19 cable should be used for all railing applications. 1x19 cable is stiff and low stretch, perfect for railings with runs up to 50 feet. 7x7 cable is more flexible with more stretch and can be used for railings with very short runs. 7x19 is very flexible and should never be used for cable rails.

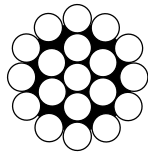

1 x 19

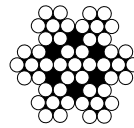

7 x 7

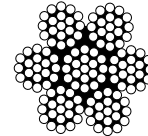

7 x 19

Q: What size cable do I use?

A: 3/16" cable is the most popular size and good for most railing applications. In high traffic applications such as airports, stadiums or amusement parks, 1/4" cable is highly recommended. For residential applications where view and unobtrusiveness are paramount, 1/8" cable works well.

Q: Do I need a turnbuckle in my cable assembly?

A: Yes. Cable works great for railing but only if you have the ability to tighten it with a turnbuckle or with a through-bolted threaded terminal. Even if you had some way of pre-tensioning the cable and attaching it without a turnbuckle or threaded terminal, the cable would eventually stretch through people leaning against it, children climbing, the building settling, etc... You want the ability to go back six months later and tighten up the cable.



Q: Does Johnson make cable assemblies?

A: No. Johnson manufactures the fittings but does not make complete cable assemblies. Our 50 year history enables Johnson to provide you with a cable fabricator near you from across the country. Please call us for the information you need.



Frequently Asked Questions

Q: How much tension do I need?

A: Johnson Architectural Hardware recommends 350 lbs. of tension on each cable assembly for a cable railing. 350 lbs. of tension is based on following the guidelines in our Basic Framework section for railing framework (please see page 7). If one follows Johnson's guidelines, Johnson knows through in-field experience and through the Modulus of Elasticity formula that code will be satisfied.

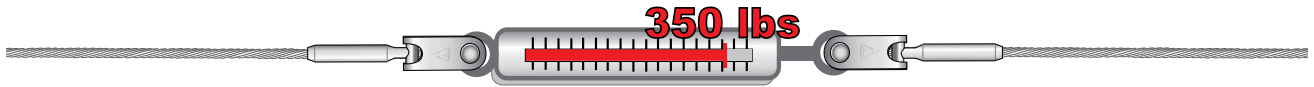

Q: Can I take 90° corners?

A: No. A true 90° corner will tweak the cable no matter what construction of cable is used. The physics of the cable does not allow the tension to be equally transmitted from one side of a corner to the other side. Tension has to be maintained throughout the entire length of the cable run to meet code. Tension in a cable is not like electricity in a wire. An end fitting should be used to make the corner transition and keep the cable tension in a straight line.

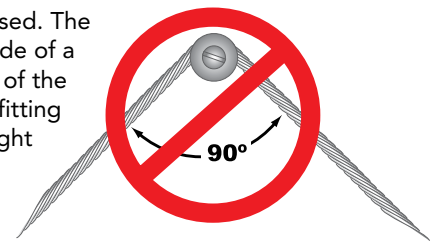

Q: What end attachments do I use?

A: End attachments are the designer's personal choice. There are many ways to accomplish the same thing with different fittings. End posts and aesthetics are the most important factors in determining end attachments. See page 32 for end fittings.



Q: What are the after swage dimensions?

A: The table below shows the After Swage Dimensions for machine swage fittings.

TERMINAL WIRE SIZE	THREAD DIAMETER	BEFORE SWAGE DIMENSION	AFTER SWAGE DIMENSION
1/8"	10-32, 1/4"	.250	.219
5/32"	1/4", 5/16"	.297	.250
3/16"	1/4", 5/16", 3/8"	.359	.313
7/32"	5/16"	.427	.375
1/4"*	5/16"	.427	.375
1/4"	3/8"	.494	.438
5/16"	1/2", 5/8"	.635	.563
3/8"	5/8"	.703	.625

NOTE: Smooth Line and Blind Thread Terminal Tuners cannot be swaged with the WireTeknik machine.

* Swages with 7/32" die.



Q: Can I make my framework out of aluminum?

A: Generally, aluminum is too soft for cable railings. Aluminum and stainless can react and cause electrolysis. If properly insulated and structurally equivalent to the framework described on page 7, an aluminum framework can be used.

Q: What grade of stainless steel does Johnson use?

A: For all major components, Johnson uses Type 316 stainless steel. Type 316 is low-carbon "18-8" chromium-nickel stainless steel modified by the addition of molybdenum, which greatly increases its corrosion resistance.

Q: Why is Johnson so strict with cable spacing, tension and framework?

A: Johnson is strict with our specifications because we want you to meet code. Cable railing is not a new business to Johnson. Johnson has been manufacturing cable fittings since 1958. Other so-called "cable experts" may tell you that you can get away with certain things, but Johnson has the experience and wants you to meet code the first time. If you follow what we prescribe in this catalog, you can be confident you will meet code.

Q: What are the after crimp dimensions for the Johnson 53-215 tool?

A: 1/8" cable = .185; 3/16" cable = .260

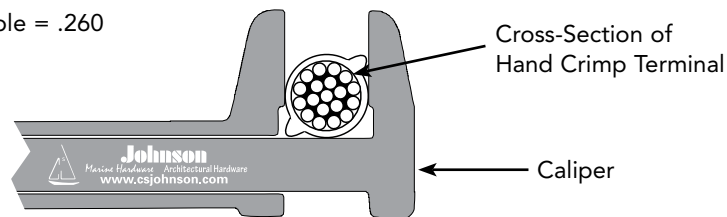

Q: How can I tell right hand thread from left hand thread?

A: Threads slope up to right when the stud is held vertically for right hand thread or slope up to the left for left hand thread.





Frequently Asked Questions

Q: Does Johnson offer fittings in steel or galvanized?

A: No

Q: What is the minimum hole size to pass a stud through an intermediate post?

A: 1/8" and 3/16" cable - 3/8" hole
1/4" cable - 1/2" hole

Q: How long can I run a single piece of cable?

A: For architectural railing purposes, cable needs to be tensioned mechanically. The most common way to do this is with a turnbuckle. Generally a conventional turnbuckle like the Johnson Classic series can tension the cable up to 50' in a straight run and meet code. Johnson's smaller fittings can meet code with runs up to 25' with an adjustable fitting at both ends.

Q: How often can I clean stainless steel?

A: Stainless steel needs to be cleaned for aesthetic considerations and to preserve corrosion resistance. Stainless steel is protected from corrosion by a thin layer of chromium oxide. Oxygen from the atmosphere combines with the chromium in the stainless steel to form this passive chromium oxide film that protects from further corrosion. Any contamination of the surface by dirt, or other material, hinders this passivation process and traps corrosive agents, reducing corrosion protection. Thus, some form of routine cleaning is necessary to preserve the appearance and integrity of the surface.

Stainless steel is easily cleaned by many different methods. Stainless steel actually thrives with frequent cleaning. Unlike some other materials, it is impossible to "wear out" stainless steel by excessive cleaning. The effect of surface/pattern roughness, grain/pattern orientation, and designs that allow for maximum rain cleaning (exterior applications) should be considered.

Stainless steel cleaning information provided by:
Specialty Steel Industry of North America
3050 K Street, N.W.
Washington, DC 20007



Private Home - Old Lyme, CT
Cable Fabricator: OCD Rigging - Chester, CT



The Via Christi Hospital - Pittsburgh, KS
Cable Fabricator: American Riggers Supply
Kansas City, KS
Installation: JE Dunn Construction
Kansas City, MO



Choosing a Turnbuckle

Johnson Architectural makes many fittings to choose from. At this point in the catalog you should have decided:

- **Do I want Machine Swage or Hand Crimp fittings?**
- **What cable size and type do I want?**
- **Will my railing framework be wood or metal?**

If you are not sure how to answer the questions above, please return to the first part of this catalog and familiarize yourself with the concepts so you have a plan.

Once you answer these questions, you are ready to choose your fittings.

Body Styles



"Terminal Tuner"
Pages 16-17



"Classic"
Pages 18-20



"Classic Shortie"
Pages 21-23



"Decko"
Pages 24-26



"Smoothline"
Pages 27-29



"Threaded"
Pages 30



"Terminator"
Pages 31

End Attachment Styles



"Button"



"Bevel"



"Ball"



"Jaw Toggle"

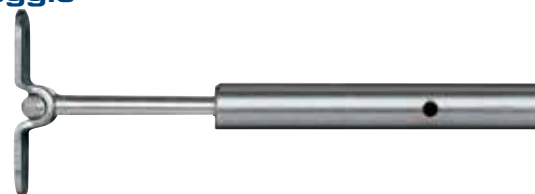

"Deck Toggle"



"Threaded"



"Terminator"



Turnbuckles

“Terminal Tuner” Turnbuckles



The Redbury South Beach - Miami, FL
Rail Fabricator: Climatrol Quality Aluminum
Cable Supplier: Sailing Services, Inc. - Miami, FL

The **Terminal Tuners Series** of turnbuckles is now available in three different styles: Button, Ball and Bevel in full or blind thread. These simple but sophisticated fittings lend themselves to metal railings with cable span lengths up to 25' if used at both ends. Button Terminal Tuners can be used on wood railings with proper washers. Ball Terminal Tuners work great at angles such as stairs. The Bevel Terminal Tuner is designed to sit flush in a 82° counter sunk hole. Three styles tuned into your needs.

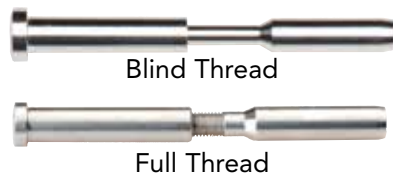

“Button” Terminal Tuner Turnbuckle

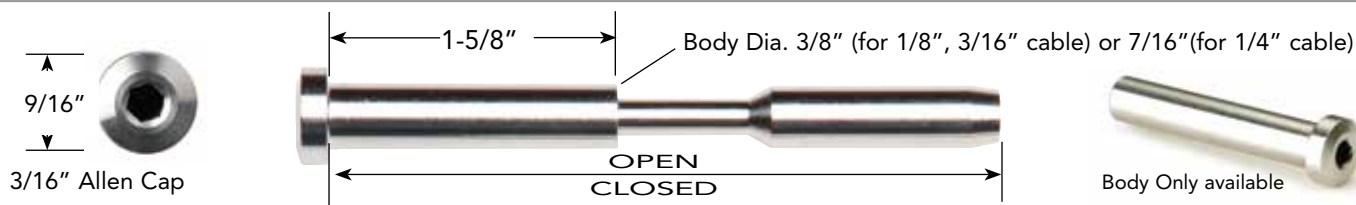

The Button Terminal Tuner Turnbuckle is a simple way to terminate cable with conventional threaded terminals. Installation and adjustment are a breeze with Terminal Tuners. Available complete with a threaded terminal or body only.

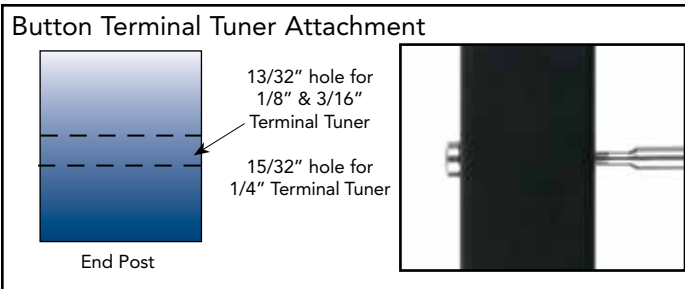

Best if used with itself...



Complete Cable Assembly (Example)



Machine Swage (TT Designates Blind Thread Version)

CAT. NO.	WIRE SIZE	THREAD SIZE	OPEN	CLOSED
35-703-4TT	1/8"	1/4"-28 R.H.	4-1/4"	2-7/8"
35-703-6TT	3/16"	1/4"-28 R.H.	4-5/8"	3-3/8"
35-705-8TT*	1/4"	5/16"-24 R.H.	4-7/8"	3-5/8"
35-703-4	1/8"	1/4"-28RH	4-1/4"	2-7/8"
35-703-6	3/16"	1/4"-28 R.H.	4-5/8"	3-3/8"
35-705-8*	1/4"	5/16"-24 R.H.	4-7/8"	3-5/8"
35-703	Body Only	1/4"-28 R.H.	---	---
35-705	Body Only	5/16"-24 R.H.	---	---

*swage with 7/32" die NOTE: Terminals for body only found on pages 11 and 20 in Marine Catalog.

Hand Crimp (TT Designates Blind Thread Version)

CAT. NO.	WIRE SIZE	THREAD SIZE	OPEN	CLOSED
26-703-4TT	1/8"	1/4"-28 R.H.	4-7/8"	3-3/8"
27-703-6TT	3/16"	1/4"-28 R.H.	5-3/8"	3-7/8"
26-703-4	1/8"	1/4"-28 R.H.	4-7/8"	3-3/8"
27-703-6	3/16"	1/4"-28 R.H.	5-3/8"	3-7/8"

Johnson Hand Crimp Tool must be used to attach fittings to cable. See page 38.

NOTE: Blind Thread Terminal Tuners cannot be swaged with the WireTeknik machine.

Turnbuckles



"Ball" Terminal Tuner Turnbuckle

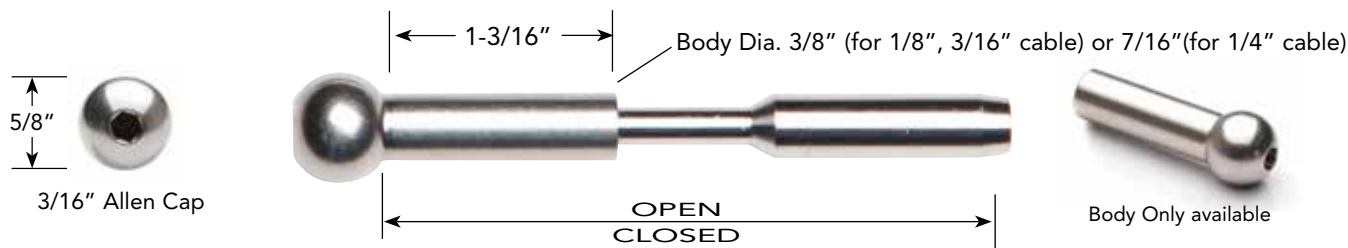

The Ball Terminal Tuner Turnbuckle is a simple fitting that will take the angle of a stair railing. The mounting holes must be drilled at the true angle or with a slot.

Best if used with itself...



Machine Swage (TT Designates Blind Thread Version)

CAT. NO.	WIRE SIZE	THREAD SIZE	OPEN	CLOSED
35-803-4TT	1/8"	1/4"-28 R.H.	4-1/4"	2-7/8"
35-803-6TT	3/16"	1/4"-28 R.H.	4-5/8"	3-3/8"
35-805-8TT*	1/4"	5/16"-24 R.H.	4-7/8"	3-5/8"
35-803-4	1/8"	1/4"-28 R.H.	4-1/4"	2-7/8"
35-803-6	3/16"	1/4"-28 R.H.	4-5/8"	3-3/8"
35-805-8*	1/4"	5/16"-24 R.H.	4-7/8"	3-5/8"
35-803	Body Only	1/4"-28 R.H.	---	---
35-805	Body Only	5/16"-24 R.H.	---	---

*swage with 7/32" die

NOTE: Terminals for body only found on pages 11 and 20 in Marine Catalog.

Complete Cable Assembly (Example)



Ball Terminal Tuner Attachment



Drill mounting holes at true angles or with slots.

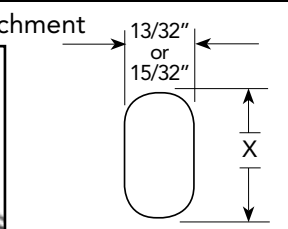

SLOT LENGTH

PLATE THICKNESS	1/4"	3/8"	1/2"
X	1/2"	19/32"	11/16"

Hand Crimp (TT Designates Blind Thread Version)

CAT. NO.	WIRE SIZE	THREAD SIZE	OPEN	CLOSED
26-803-4TT	1/8"	1/4"-28 R.H.	4-7/8"	3-3/8"
27-803-6TT	3/16"	1/4"-28 R.H.	5-3/8"	3-7/8"
26-803-4	1/8"	1/4"-28 R.H.	4-7/8"	3-3/8"
27-803-6	3/16"	1/4"-28 R.H.	5-3/8"	3-7/8"

Johnson Hand Crimp Tool must be used to attach fittings to cable. See page 38.

"Bevel" Terminal Tuner Turnbuckle

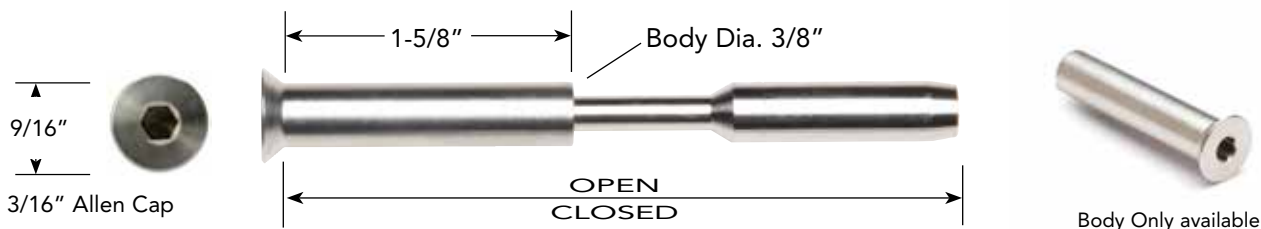

The Bevel Terminal Tuner Turnbuckle is a great way to terminate cable in a flush fitting. A 82° counter sink makes the bevel sit flush for a clean simple look. To be used for straight runs only.

Best if used with itself...



Complete Cable Assembly (Example)



Terminal Tuner Attachment

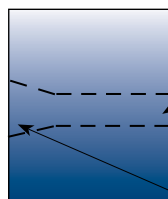

13/32" hole for 1/8" & 3/16" Terminal Tuner



Sits Flush

End Post
82° counter sink at 3/32"

Machine Swage (TT Designates Blind Thread Version)

CAT. NO.	WIRE SIZE	THREAD SIZE	OPEN	CLOSED
35-713-4TT	1/8"	1/4"-28 R.H.	4-1/4"	2-7/8"
35-713-6TT	3/16"	1/4"-28 R.H.	4-5/8"	3-3/8"
35-713-4	1/8"	1/4"-28 R.H.	4-1/4"	2-7/8"
35-713-6	3/16"	1/4"-28 R.H.	4-5/8"	3-3/8"
35-713	Body Only	1/4"-28 R.H.	---	---

NOTE: Terminals for body only found on pages 11 and 20 in Marine Catalog.

Hand Crimp (TT Designates Blind Thread Version)

CAT. NO.	WIRE SIZE	THREAD SIZE	OPEN	CLOSED
26-713-4TT	1/8"	1/4"-28 R.H.	4-7/8"	3-3/8"
27-713-6TT	3/16"	1/4"-28 R.H.	5-3/8"	3-7/8"
26-713-4	1/8"	1/4"-28 R.H.	4-7/8"	3-3/8"
27-713-6	3/16"	1/4"-28 R.H.	5-3/8"	3-7/8"

Johnson Hand Crimp Tool must be used to attach fittings to cable. See page 38.



“Classic Style” Turnbuckles

Turnbuckles



Private Home - Block Island, RI
Cable Fabricator: Nature's View Railing - Waterford, CT

You can't go wrong with Johnson's **Classic Series Turnbuckles**. The Classic Series Turnbuckles are based on classic yacht turnbuckles and come in five styles: Jaw, Deck Toggle, Button, Ball and Swage to Swage. The Classic Series will work on wood and metal railing with cable spans up to 50'. Classic Jaw Turnbuckles attach with a clevis pin to eyes or welded tabs. Classic Deck Toggle Turnbuckles are fastened with two screws to a flat surface. Classic Button Turnbuckles work great on metal railings but can be used on wood railings with proper washers. Stair angles are not a problem with Classic Ball Turnbuckles. When a turnbuckle is desired in the middle of a cable run the Classic Swage to Swage Turnbuckle is a great choice. When in doubt go with a Classic Series Turnbuckle.

Classic Jaw Turnbuckle



The Classic Jaw and Swage Turnbuckle is an excellent choice for a wide variety of applications. A clevis pin in the jaw attaches to eyes, tabs or in a channel. Can be used in straight run or at an angle. Larger sizes available. Please see page 29 in Marine Catalog.

Best if used with Toggle Jaw...



(see pg. 32)

Jaw Attachment Tab

Can also use Security Bolt (see pg. 33)

For Pin	D (Hole Dia.)	E (Dist. from Edge)	L (Length)	H (Min. Height)	W (Stock Width)
1/4"	9/32"	5/16"	3/4"	1"	1/4"
5/16"	11/32"	3/8"	1-1/4"	1-1/2"	5/16"
3/8"	25/64"	1/2"	1-1/4"	1-1/2"	3/8"

Complete Cable Assembly (Example)



Machine Swage

CAT. NO.	WIRE SIZE	THREAD SIZE	OPEN	CLOSED
19-314	1/8"	1/4"	11-1/4"	8-1/4"
19-316	3/16"	1/4"	11-1/4"	8-1/4"
19-318-7*	1/4"	5/16"	12-3/4"	9"
19-308	1/4"	3/8"	14-1/4"	10"

*swage with 7/32" die

Hand Crimp

CAT. NO.	WIRE SIZE	THREAD SIZE	OPEN	CLOSED
26-412	1/8"	1/4"	11-5/8"	8-3/4"
27-412	3/16"	1/4"	11-5/8"	8-3/4"

Johnson Hand Crimp Tool must be used to attach fittings to cable. See page 38.



Classic Deck Toggle Turnbuckle



Our Classic Deck Toggle and Swage Turnbuckle can be mounted to any flat surface and is held in place by two tabs suitable for through bolting. The best feature of the deck toggle is it can articulate 140 degrees.

Best if used with Deck Terminal...



Complete Cable Assembly (Example)



Deck Toggle Attachment

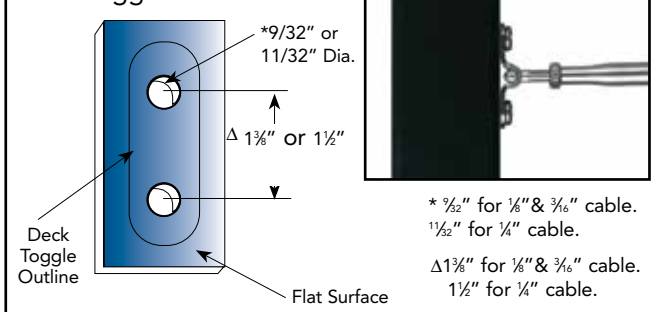

Machine Swage

CAT. NO.	WIRE SIZE	THREAD SIZE	OPEN	CLOSED
19-314-1T	1/8"	1/4"	10-3/4"	7-3/4"
19-316-1T	3/16"	1/4"	11-1/4"	8-1/4"
19-318-1T*	1/4"	5/16"	12"	9"

*swage with 7/32" die

Hand Crimp

CAT. NO.	WIRE SIZE	THREAD SIZE	OPEN	CLOSED
26-412-1T	1/8"	1/4"	11-1/2"	8-1/2"
27-412-1T	3/16"	1/4"	11-1/2"	8-1/2"

Johnson Hand Crimp Tool must be used to attach fittings to cable. See page 38.

Classic Button Turnbuckle



The Classic Button and Swage Turnbuckle has a clean simple look with no jaw. It must be used on a straight run and attached in a through hole with the button on the backside of the baluster.

Best if used with Button Terminal...



Complete Cable Assembly (Example)



Button Attachment

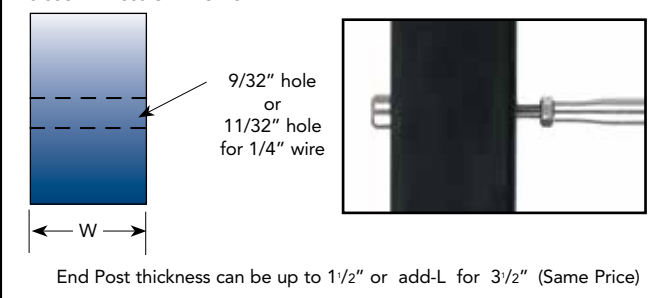

Machine Swage

CAT. NO.	WIRE SIZE	THREAD SIZE	OPEN	CLOSED
19-314-10F	1/8"	1/4"	11-1/2"	8-1/4"
19-316-10F	3/16"	1/4"	11-1/2"	8-1/4"
19-308-7F*	1/4"	5/16"	14-1/4"	10-1/2"

*Swage with 7/32" die. 1/4" does not come as shown with interrupted thread. All-thread standard.

Hand Crimp

CAT. NO.	WIRE SIZE	THREAD SIZE	OPEN	CLOSED
26-412-10F	1/8"	1/4"	11-11/16"	8-1/8"
27-412-10F	3/16"	1/4"	12"	8-1/2"

Johnson Hand Crimp Tool must be used to attach fittings to cable. See page 38.



Classic Ball End Turnbuckle



The Classic Ball End and Swage Turnbuckle is made to accept the angles of stairways. The Ball End allows the turnbuckle to integrate itself to your desired angle. The ball allows this turnbuckle to gimbal in its mount.

Note: 5/32" cable size available

Best if used with Ball End Terminal...



(see pg. 32)

Ball End Attachment

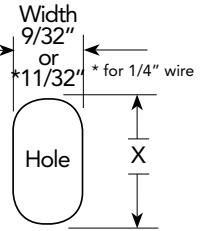

Drill mounting holes at true angles or with slots.

SLOT LENGTH

PLATE THICKNESS	1/4"	3/8"	1/2"
X	1/2"	19/32"	11/16"

Complete Cable Assembly (Example)



Machine Swage

CAT. NO.	WIRE SIZE	THREAD SIZE	OPEN	CLOSED
19-314-10B	1/8"	1/4"	11-1/4"	8-1/4"
19-316-10B	3/16"	1/4"	11-1/4"	8-1/4"
19-308-7B*	1/4"	5/16"	14-1/8"	10-1/4"

*Swage with 7/32" die. 1/4" does not come as shown with interrupted thread. All-thread standard.

Hand Crimp

CAT. NO.	WIRE SIZE	THREAD SIZE	OPEN	CLOSED
26-412-10B	1/8"	1/4"	11-11/16"	8-1/8"
27-412-10B	3/16"	1/4"	12"	8-1/2"

Johnson Hand Crimp Tool must be used to attach fittings to cable. See page 38.

Classic Swage to Swage Turnbuckle



Appearing in the middle of the cable, the Classic Swage to Swage Turnbuckle needs a fitting at each end to make a complete assembly. You need to use three fittings per cable run, but it makes for a distinctive look.

Swage to Swage

Swage to swage appears in the middle of the cable run.



Can be used with Toggle Jaw or etc...



(see pg. 32)

Complete Cable Assembly (Example)



Machine Swage

CAT. NO.	WIRE SIZE	THREAD SIZE	OPEN	CLOSED
19-314-3	1/8"	1/4"	11-3/4"	8-3/4"
19-316-6	3/16"	1/4"	11-3/4"	8-3/4"
19-308-27*	1/4"	5/16"	13-1/4"	9-3/4"
19-308-2	1/4"	3/8"	14-7/8"	10-5/8"

* Swage with 7/32" die.

Hand Crimp

CAT. NO.	WIRE SIZE	THREAD SIZE	OPEN	CLOSED
26-412-3	1/8"	1/4"	12-1/2"	9-1/2"
27-412-6	3/16"	1/4"	12-1/2"	9-1/2"

Johnson Hand Crimp Tool must be used to attach fittings to cable. See page 38.

Turnbuckles



“Shortie” Turnbuckles

If you think the Classics are too long, we have you covered. You can also choose from the “Shortie” Turnbuckle Series. The Shorties have all the same great features the Classics have just in a 1 ½’ shorter length. For runs up to 25’ in length you can choose from Jaw, Deck Toggle, Button, Ball and Swage to Swage turnbuckle.

All the big features are here in a small package. Some times it’s good to be short.



Waterfront Railing - Northern California

Cable Fabricator: San Diego Cable Railings - San Diego, CA

“Shortie” Jaw Turnbuckle

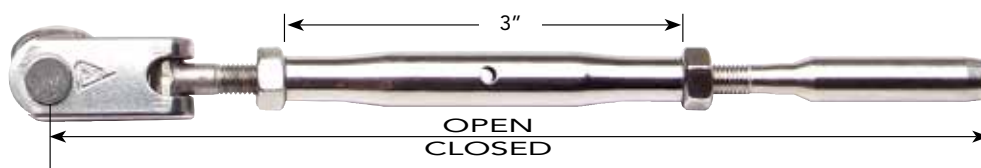

The “Shortie” Jaw and Swage Turnbuckle is an excellent choice for a wide variety of applications. A clevis pin in the jaw attaches to eyes, tabs or in a channel. Can be used in straight run or at an angle. Larger sizes available. Please see page 29 in Marine Catalog.

Best if used with Toggle Jaw...



(see pg. 32)

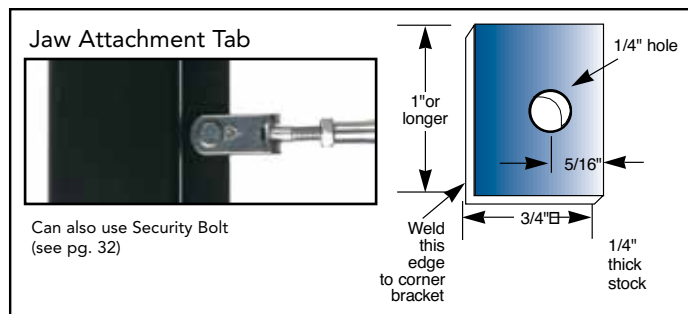

Complete Cable Assembly (Example)



Machine Swage

CAT. NO.	WIRE SIZE	THREAD SIZE	OPEN	CLOSED
19-314S	1/8"	1/4"	8-1/4"	6-1/4"
19-316S	3/16"	1/4"	8-1/2"	6-1/2"

NOTE: Not available for 1/4" cable.

Hand Crimp

CAT. NO.	WIRE SIZE	THREAD SIZE	OPEN	CLOSED
26-412S	1/8"	1/4"	8-3/4"	6-3/4"
27-412S	3/16"	1/4"	9"	7"

Johnson Hand Crimp Tool must be used to attach fittings to cable. See page 38.



Turnbuckles

Not for lifting, hanging or other high load applications. See Marine Catalog for Rigging Hardware.

"Shortie" Deck Toggle Turnbuckle



Our "Shortie" Deck Toggle and Swage Turnbuckle can be mounted to any flat surface and is held in place by two tabs suitable for through bolting. The best feature of the deck toggle is it can articulate 140 degrees.

Best if used with Deck Terminal...



Complete Cable Assembly (Example)



Deck Toggle Attachment

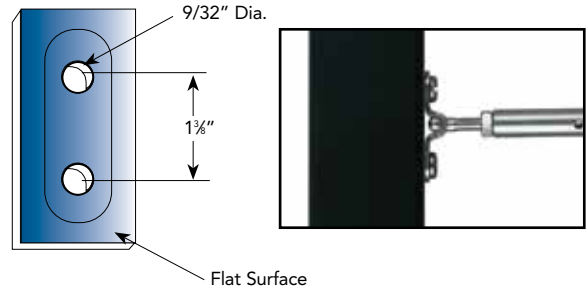

Machine Swage

CAT. NO.	WIRE SIZE	THREAD SIZE	OPEN	CLOSED
19-314-1TS	1/8"	1/4"	7-1/2"	5-1/2"
19-316-1TS	3/16"	1/4"	7-3/4"	5-3/4"

NOTE: Not available for 1/4" cable.

Hand Crimp

CAT. NO.	WIRE SIZE	THREAD SIZE	OPEN	CLOSED
26-412-1TS	1/8"	1/4"	8-1/4"	6-1/4"
27-412-1TS	3/16"	1/4"	8-1/2"	6-1/2"

Johnson Hand Crimp Tool must be used to attach fittings to cable. See page 38.

"Shortie" Button Turnbuckle

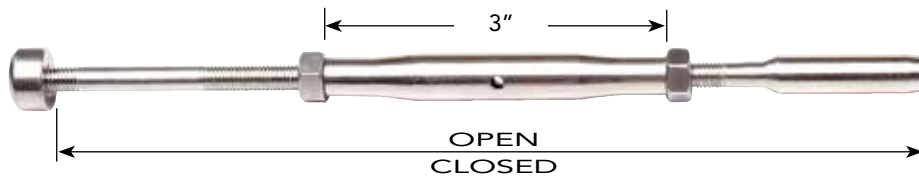

The "Shortie" Button and Swage Turnbuckle has a clean simple look with no jaw. It must be used on a straight run and attached in a through hole with the button on the backside of the baluster.

Best if used with Button Terminal...



Complete Cable Assembly (Example)



Button Attachment



End Post thickness can be up to 1/2" or add-L for 3/2" (Same Price)

Machine Swage

CAT. NO.	WIRE SIZE	THREAD SIZE	OPEN	CLOSED
19-314-10FS	1/8"	1/4"	9-1/4"	7-1/4"
19-316-10FS	3/16"	1/4"	9-1/2"	7-1/2"

NOTE: Not available for 1/4" cable.

Hand Crimp

CAT. NO.	WIRE SIZE	THREAD SIZE	OPEN	CLOSED
26-412-10FS	1/8"	1/4"	9-3/4"	7-3/4"
27-412-10FS	3/16"	1/4"	10"	8"

Johnson Hand Crimp Tool must be used to attach fittings to cable. See page 38.

Turnbuckles



“Shortie” Ball End Turnbuckle

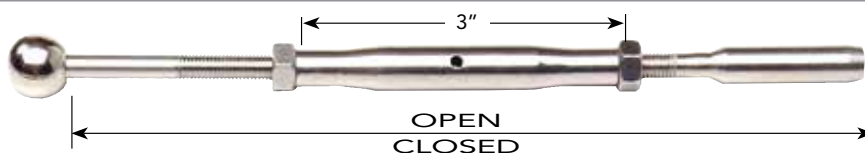

The “Shortie” Ball End and Swage Turnbuckle is made to accept the angles of stairways. The Ball End allows the turnbuckle to integrate itself to your desired angle. The ball allows this turnbuckle to gimbal in its mount.

Note: 5/32” cable size available

Best if used with Ball End Terminal...



(see pg. 32)

Ball End Attachment

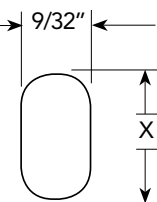

Drill mounting holes at true angles or with slots.

SLOT LENGTH				
PLATE THICKNESS	1/4"	3/8"	1/2"	
X	1/2"	19/32"	11/16"	

Complete Cable Assembly (Example)



Machine Swage

CAT. NO.	WIRE SIZE	THREAD SIZE	OPEN	CLOSED
19-314-10BS	1/8"	1/4"	9"	7"
19-316-10BS	3/16"	1/4"	9-1/4"	7-1/4"

NOTE: Not available for 1/4" cable.

Hand Crimp

CAT. NO.	WIRE SIZE	THREAD SIZE	OPEN	CLOSED
26-412-10BS	1/8"	1/4"	9-1/2"	7-1/2"
27-412-10BS	3/16"	1/4"	9-3/4"	7-3/4"

Johnson Hand Crimp Tool must be used to attach fittings to cable. See page 38.

“Shortie” Swage to Swage Turnbuckle



Appearing in the middle of the cable, the “Shortie” Swage to Swage Turnbuckle needs a fitting at each end to make a complete assembly. You need to use three fittings per cable run, but it makes for a distinctive look.

Can be used with Toggle Jaw or etc...



(see pg. 32)

Swage to Swage

Swage to swage appears in the middle of the cable run.



Complete Cable Assembly (Example)



Machine Swage

CAT. NO.	WIRE SIZE	THREAD SIZE	OPEN	CLOSED
19-314-3S	1/8"	1/4"	8-1/4"	6-1/4"
19-316-6S	3/16"	1/4"	9"	7"

NOTE: Not available for 1/4" cable.

Hand Crimp

CAT. NO.	WIRE SIZE	THREAD SIZE	OPEN	CLOSED
26-412-3S	1/8"	1/4"	9"	7"
27-412-6S	3/16"	1/4"	10"	8"

Johnson Hand Crimp Tool must be used to attach fittings to cable. See page 38.



“Decko Style” Turnbuckles



Cross Insurance Center - Bangor, ME
Fabricator: NE Tech Air & Maine Steel - Scarborough, ME

The **Decko Series** of turnbuckles are slightly shorter and sleeker than the Classic Series and come in five styles: Jaw, Deck Toggle, Button, Ball and Swage to Swage. Cable spans up to 25' on wood and metal railings can be made with the Decko Series. Decko Jaw Turnbuckles attach with a clevis pin to eyes or welded tabs. Decko Deck Toggle Turnbuckles are fastened with two screws to a flat surface. Decko Button Turnbuckles work great on metal railings but can be used on wood railings with proper washers. Stair angles are not a problem with Decko Ball Turnbuckles. When a turnbuckle is desired in the middle of a cable run the Decko Swage to Swage Turnbuckle is a great choice. The Decko Series is the right choice when a contemporary look is needed.

Turnbuckles

Decko Jaw to Swage Turnbuckle

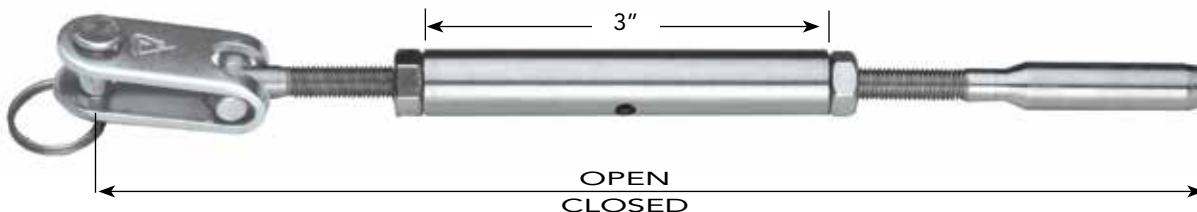

The Decko Jaw and Swage Turnbuckle is an excellent choice for a wide variety of applications. A clevis pin in the jaw attaches to eyes, tabs or in a channel. Can be used in straight runs or at an angle.

Best if used with Toggle Jaw...



(see pg. 32)

Complete Cable Assembly (Example)



Jaw Attachment Tab

Can also use Security Bolt (See pg. 29).

Machine Swage

CAT. NO.	WIRE SIZE	THREAD SIZE	OPEN	CLOSED
19-314-DE	1/8"	1/4"	8-1/4"	6-1/4"
19-316-DE	3/16"	1/4"	8-1/2"	6-1/2"

NOTE: Not available for 1/4" cable.

Hand Crimp

CAT. NO.	WIRE SIZE	THREAD SIZE	OPEN	CLOSED
26-412-DE	1/8"	1/4"	8-3/4"	6-3/4"
27-412-DE	3/16"	1/4"	9"	7"

Johnson Hand Crimp Tool must be used to attach fittings to cable. See page 38.



Decko Deck Toggle Turnbuckle

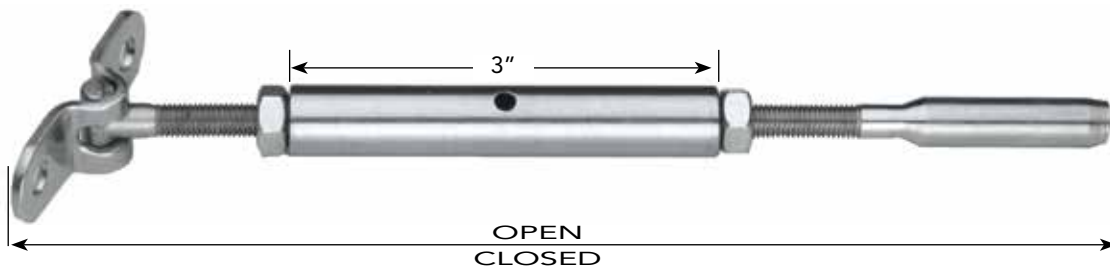

Our Decko Deck Toggle and Swage Turnbuckle can be mounted to any flat surface and is held in place by two tabs suitable for through bolting. The best feature of the deck toggle is it can articulate 140 degrees.

Best if used with Deck Toggle...



Deck Toggle Attachment

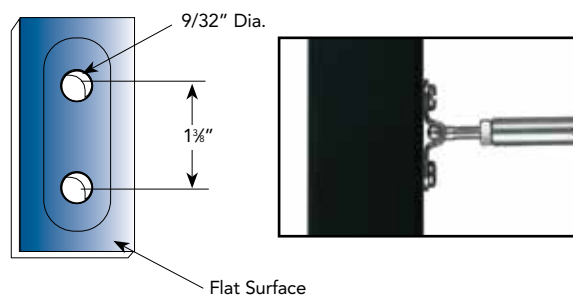

Complete Cable Assembly (Example)



Machine Swage

CAT. NO.	WIRE SIZE	THREAD SIZE	OPEN	CLOSED
19-314-1T-DE	1/8"	1/4"	7-1/2"	5-1/2"
19-316-1T-DE	3/16"	1/4"	7-3/4"	5-3/4"

NOTE: Not available for 1/4" cable.

Hand Crimp

CAT. NO.	WIRE SIZE	THREAD SIZE	OPEN	CLOSED
26-412-1T-DE	1/8"	1/4"	8-1/4"	6-1/4"
27-412-1T-DE	3/16"	1/4"	8-1/2"	6-1/2"

Johnson Hand Crimp Tool must be used to attach fittings to cable. See page 38.

Decko Button Turnbuckle



The Decko Button and Swage Turnbuckle has a clean simple look with no jaw. It must be used on a straight run and attached in a through hole with the button on the backside of the baluster.

Best if used with Button Terminal...



Button Attachment



End Post thickness can be up to 1/2" or add-L for 3/2" (Same Price)

Complete Cable Assembly (Example)



Machine Swage

CAT. NO.	WIRE SIZE	THREAD SIZE	OPEN	CLOSED
19-314-10F-DE	1/8"	1/4"	9-1/4"	7-1/4"
19-316-10F-DE	3/16"	1/4"	9-1/2"	7-1/2"

NOTE: Not available for 1/4" cable.

Hand Crimp

CAT. NO.	WIRE SIZE	THREAD SIZE	OPEN	CLOSED
26-412-10F-DE	1/8"	1/4"	9-3/4"	7-3/4"
27-412-10F-DE	3/16"	1/4"	10"	8"

87.



Decko Ball End Turnbuckle

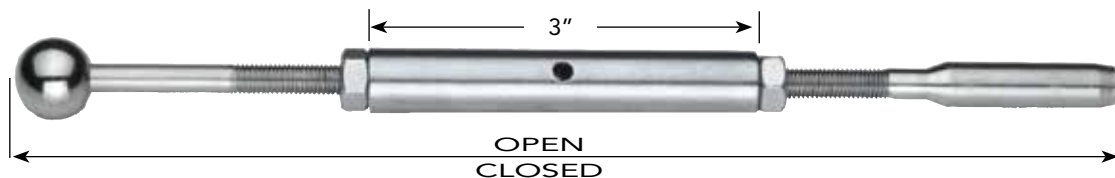

The Decko Ball End and Swage Turnbuckle is made to accept the angles of stairways. The Ball End allows the turnbuckle to integrate itself to your desired angle. The ball allows this turnbuckle to gimbal in its mount.

Ball End Attachment

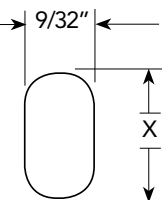

Drill mounting holes at true angles or with slots.

SLOT LENGTH			
PLATE THICKNESS	1/4"	3/8"	1/2"
X	1/2"	19/32"	11/16"

Best if used with Ball Terminal...



(see pg. 32)

Complete Cable Assembly (Example)



Machine Swage

CAT. NO.	WIRE SIZE	THREAD SIZE	OPEN	CLOSED
19-314-10B-DE	1/8"	1/4"	9"	7"
19-316-10B-DE	3/16"	1/4"	9-1/4"	7-1/4"

NOTE: Not available for 1/4" cable.

Hand Crimp

CAT. NO.	WIRE SIZE	THREAD SIZE	OPEN	CLOSED
26-412-10B-DE	1/8"	1/4"	9-1/2"	7-1/2"
27-412-10B-DE	3/16"	1/4"	9-3/4"	7-3/4"

Johnson Hand Crimp Tool must be used to attach fittings to cable. See page 38.

Decko Swage to Swage Turnbuckle



Appearing in the middle of the cable, the Decko Swage to Swage Turnbuckle needs a fitting at each end to make a complete assembly. You need to use three fittings per cable run, but it makes for a distinctive look.

Best if used with Toggle Jaw...



(see pg. 32)

Swage to Swage

Swage to swage appears in the middle of the cable run.



Complete Cable Assembly (Example)



Machine Swage

CAT. NO.	WIRE SIZE	THREAD SIZE	OPEN	CLOSED
19-314-3DE	1/8"	1/4"	8-1/4"	6-1/4"
19-316-6DE	3/16"	1/4"	9"	7"

NOTE: Not available for 1/4" cable.

Hand Crimp

CAT. NO.	WIRE SIZE	THREAD SIZE	OPEN	CLOSED
26-412-3DE	1/8"	1/4"	9"	7"
27-412-6DE	3/16"	1/4"	10"	8"

Johnson Hand Crimp Tool must be used to attach fittings to cable. See page 38.



“Smooth Line” Turnbuckles

State-of-the-Art best describes the **Smooth Line Series**. These top shelf turnbuckles have no exposed thread and allow the cable to terminate internally inside the body of the turnbuckle. The Smooth Line Series looks smooth on the outside but hide their essentials internally. The Smooth Line Series work on wood and metal rails with cable spans up to 25' and are available in five styles: Jaw, Deck Toggle, Button, Ball and Threaded Terminal. Smooth Line Jaw Turnbuckles attach with a clevis pin to eyes or welded tabs. Smooth Line Deck Toggle Turnbuckles are fastened with two screws to a flat surface. Smooth Line Button Turnbuckles work great on metal railings but can be used on wood railings with proper washers. Stair angles are not a problem with Smooth Line Ball Turnbuckles. When you want the best specify Smooth Line Turnbuckles.



Portland Regency Hotel - Portland, ME
Cable Fabricator: NE Tech Air & Maine Steel - Scarborough, ME

Turnbuckles



“Smooth Line” End Fittings Now Available. (See pg 32)



Replacement parts on pages 8 and 16 of Marine Catalog.

Jaw Smooth Line Turnbuckle

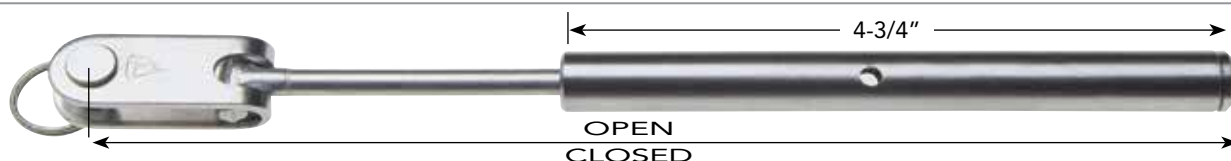

The Smooth Line Turnbuckles are state-of-the-art fittings. The cable is terminated internally. One does not see a swage terminal (or threads) as on a conventional turnbuckle. The Jaw Smooth Line Turnbuckle adapts itself to a wide variety of projects. The jaw will easily attach to eyes, tabs or in a channel.

Best if used with Smooth Line Toggle Jaw...



(see pg. 32)

Complete Cable Assembly (Example)



Machine Swage

CAT. NO.	WIRE SIZE	THREAD SIZE	OPEN	CLOSED
60-700	1/8"	1/4"	8"	6-5/16"
60-702	3/16"	1/4"	8"	6-5/16"
60-704*	1/4"	5/16"	9"	7"

*swage with 7/32" die.
Does not work with Wireteknik Swaging Machines.

Hand Crimp

CAT. NO.	WIRE SIZE	THREAD SIZE	OPEN	CLOSED
26-715	1/8"	1/4"	8"	6-5/16"
27-715	3/16"	1/4"	8"	6-5/16"

Johnson Hand Crimp Tool must be used to attach fittings to cable. See page 38.

Jaw Attachment Tab



Can also use Security Bolt (See Pg. 27)

For Pin	D (Hole Dia.)	E (Dist. from Edge)	L (Length)	H (Min. Height)	W (Stock Width)
1/4"	9/32"	5/16"	3/4"	1"	1/4"
5/16"	11/32"	3/8"	1-1/4"	1-1/2"	5/16"



Deck Toggle Smooth Line Turnbuckle

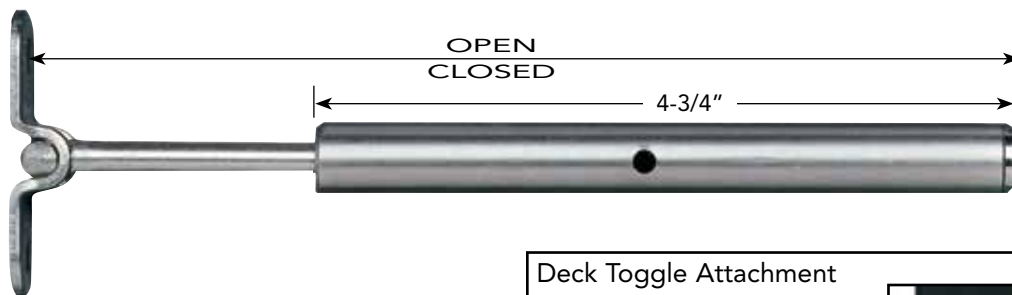

The Deck Toggle Smooth Line Turnbuckle will mount to any flat surface. It can be through bolted by its two tabs and also has the ability to toggle 140 degrees.

Best if used with a Smooth Line Deck Terminal...

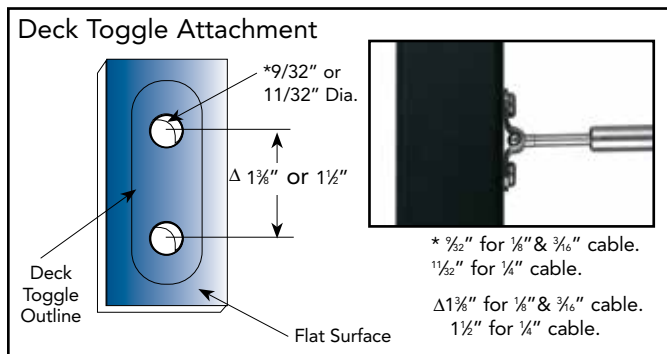

Complete Cable Assembly (Example)



Machine Swage

CAT. NO.	WIRE SIZE	THREAD SIZE	OPEN	CLOSED
60-700-1	1/8"	1/4"	8"	6-5/16"
60-702-1	3/16"	1/4"	8"	6-5/16"
60-704-1*	1/4"	5/16"	8"	6"

*swage with 7/32" die. Does not work with Wiretechnik Swaging Machines.

Hand Crimp

CAT. NO.	WIRE SIZE	THREAD SIZE	OPEN	CLOSED
26-715-1	1/8"	1/4"	8"	6-5/16"
27-715-1	3/16"	1/4"	8"	6-5/16"

Johnson Hand Crimp Tool must be used to attach fittings to cable. See page 38.

Button Smooth Line Turnbuckle

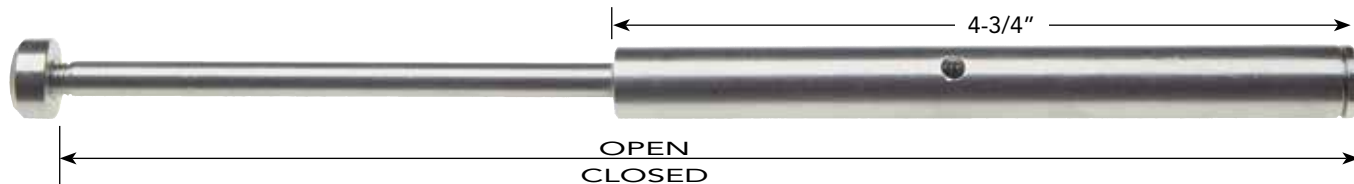

The Button Smooth Line Turnbuckle has the cleanest, simplest look of all the Smooth Lines. The button retains the fitting in a through hole in the baluster. The fitting is used in straight line runs.

Best if used with a Smooth Line Button Terminal...

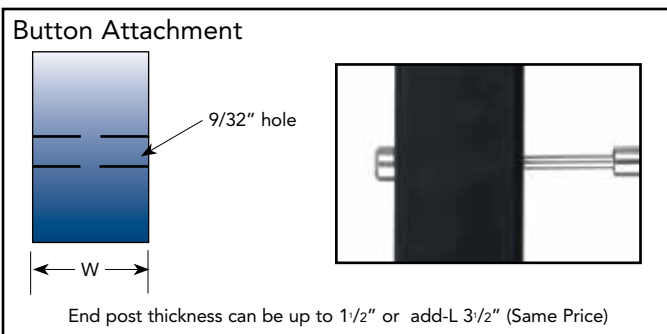

Complete Cable Assembly (Example)



Machine Swage

CAT. NO.	WIRE SIZE	THREAD SIZE	OPEN	CLOSED
60-710-LF	1/8"	1/4"	9-9/16"	7-13/16"
60-712-LF	3/16"	1/4"	9-9/16"	7-13/16"
60-714-LF*	1/4"	5/16"	10"	8"

*swage with 7/32" die. Does not work with Wiretechnik Swaging Machines.

Hand Crimp

CAT. NO.	WIRE SIZE	THREAD SIZE	OPEN	CLOSED
26-725-LF	1/8"	1/4"	9-9/16"	7-13/16"
27-725-LF	3/16"	1/4"	9-9/16"	7-13/16"

Johnson Hand Crimp Tool must be used to attach fittings to cable. See page 38.



Ball End Smooth Line Turnbuckle

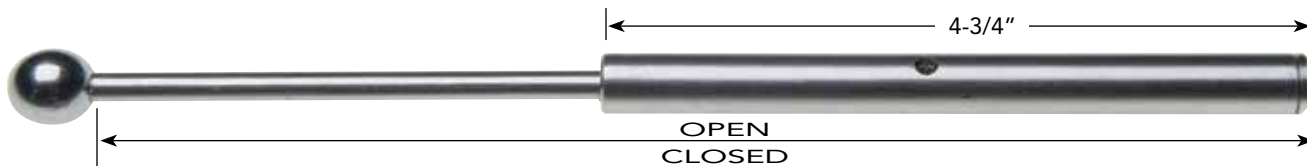

The Ball End Smooth Line Turnbuckle gimbals in its own mount, making it the turnbuckle of choice on stairways or anywhere a cable installation at a divergent angle is needed.

Best if used with a Smooth Line Ball Terminal...



Ball End Attachment

Width 9/32" or 11/32" * for 1/4" wire

Hole

X

Drill mounting holes at true angles or with slots.

SLOT LENGTH			
PLATE THICKNESS	1/4"	3/8"	1/2"
X	1/2"	19/32"	11/16"

Complete Cable Assembly (Example)



Machine Swage

CAT. NO.	WIRE SIZE	THREAD SIZE	OPEN	CLOSED
60-710-LB	1/8"	1/4"	9-9/16"	7-13/16"
60-712-LB	3/16"	1/4"	9-9/16"	7-13/16"
60-714-LB*	1/4"	5/16"	10"	8"

*swage with 7/32" die. Does not work with Wireteknik Swaging Machines.

Hand Crimp

CAT. NO.	WIRE SIZE	THREAD SIZE	OPEN	CLOSED
26-725-LB	1/8"	1/4"	9-9/16"	7-13/16"
27-725-LB	3/16"	1/4"	9-9/16"	7-13/16"

Johnson Hand Crimp Tool must be used to attach fittings to cable. See page 38.

Smooth Line Threaded Terminal



The Smooth Line Stud Terminal provides for smooth hidden cable attachment to threaded terminals. Simple and clean, these fittings really lend themselves to Hand Crimp installations.

Best if used with itself...



Stud Terminal Attachment

9/32" hole, 1/4" thread

11/32" hole, 5/16" thread

W

End Post Thickness can be up to 3/2"

Complete Cable Assembly (Example)



Machine Swage

CAT. NO.	WIRE SIZE	THREAD SIZE	LENGTH
25-500	1/8"	1/4" x 28 x 2-1/2"	6-1/4"
25-500-L	1/8"	1/4" x 28 x 2-1/2"	8-5/8"
25-502	3/16"	1/4" x 28 x 2-1/2"	6-1/4"
25-502-L	3/16"	1/4" x 28 x 2-1/2"	8-5/8"
25-504-3*	1/4"	5/16" x 24 x 3"	5-3/4"
25-504-6*	1/4"	5/16" x 24 x 6"	8-1/2"

*swage with 7/32" die. Does not work with Wireteknik Swaging Machines.

Hand Crimp

CAT. NO.	WIRE SIZE	THREAD SIZE	LENGTH
26-500	1/8"	1/4" x 28 x 2-1/2"	6-1/4"
26-500-L	1/8"	1/4" x 28 x 2-1/2"	8-5/8"
27-500	3/16"	1/4" x 28 x 2-1/2"	6-1/4"
27-500-L	3/16"	1/4" x 28 x 2-1/2"	8-5/8"

Johnson Hand Crimp Tool must be used to attach fittings to cable. See page 38.



Threaded Terminals and Terminator Turnbuckles



The most economical and simplest way to make cable assemblies is with Threaded Terminals. Threaded Terminals used at both ends can span up to 50'. You must have access to the back side of the end post to assemble nuts and washers as the Threaded Terminals through bolt through the posts.

Terminator Turnbuckles are available in Machine Swage only and will make cable assemblies up to 25' when used at both ends. Terminator Turnbuckles only use course thread so you can purchase the body only and use a screw of your choice or buy complete with a screw.

YMCA - Amherst, NY

Cable Fabricator: Architectural Wire Works, Inc. - Buffalo, NY

Rail Fabricator: Apollo Steel Corp. - Niagra Falls, NY

Threaded Terminal

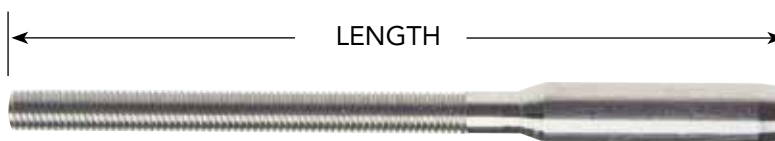

The simplest way to make a cable assembly is with a threaded terminal at each end. Clean and simple, this style can span up to 50 ft. in a straight run. Larger sizes available. Please see page 35 in the Marine Catalog.

Best if used with Threaded Terminal...



Threaded Terminal Attachment

9/32" hole, 1/4" thread
11/32" hole, 5/16" thread
13/32" hole, 3/8" thread

End Post Thickness can be up to 3/2"



Machine Swage

CAT. NO.	WIRE SIZE	THREAD SIZE	LENGTH
30-603-1	1/8"	1/4-28 x 2-1/2"	3-3/4"
30-603-1L	1/8"	1/4-28 x 2-1/2"	7-9/16"
30-608-1	3/16"	1/4-28 x 2-1/2"	4-1/4"
30-615-1*	1/4"	5/16-24 x 2-3/4"	4-3/4"
30-613-1	1/4"	3/8-24 x 3"	5-1/4"
25-316-L	3/16"	1/4-28 x 2-1/2"	7-9/16"

*swage with 7/32" die.

Hand Crimp

CAT. NO.	WIRE SIZE	THREAD SIZE	LENGTH
31-603-1	1/8"	1/4-28 x 2-1/2"	4-7/16"
31-607-1	3/16"	1/4-28 x 2-1/2"	4-13/16"
27-415-L	3/16"	1/4-28 x 2-1/2"	8-3/8"

Johnson Hand Crimp Tool must be used to attach fittings to cable. See page 38.

LONG VERSION - #25-316-L



Turnbuckles



"The Terminator" Turnbuckle

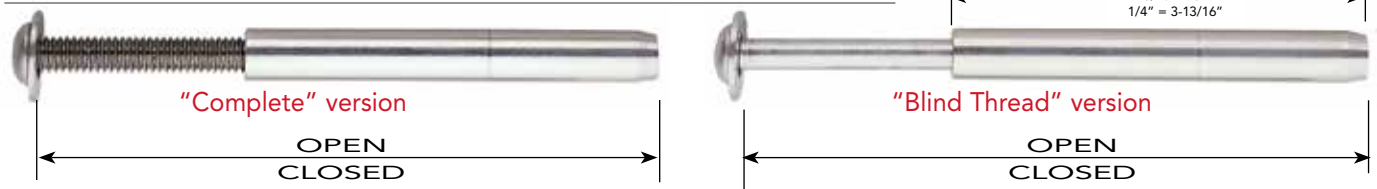

So simple but so effective, the Terminator Turnbuckle is an easy choice for railings or glass shelves. 3/16" Terminators work great for railings. 1/8" Terminators work great with Johnson's Glass Shelf Fittings. Machine swage only.

Best if used with itself...



1/8" does not work with Wiretekniiks Swaging Machines.

Complete Cable Assembly (Example)



Machine Swage

CAT. NO.	WIRE SIZE	THREAD SIZE	OPEN	CLOSED	DESCRIPTION
80-101	1/8"	10-24	3-3/4"	2-5/8"	Complete
80-103	3/16"	1/4x20	5-9/16"	4-3/8"	Complete
80-54	1/8"	10-24	—	—	Body Only
80-56	3/16"	1/4x20	—	—	Body Only
80-105	3/16"	1/4x20	6-1/2"	5-1/2"	Blind Thread
80-66*	1/4"	5/16"x18	—	—	Body Only
80-107*	1/4"	5/16"x18	7-1/4"	5-1/4"	Complete

*swage with 7/32" die

NOTE: "Body Only" comes with no screw.

Available in Machine Swage only.

"The Terminator" Attachment

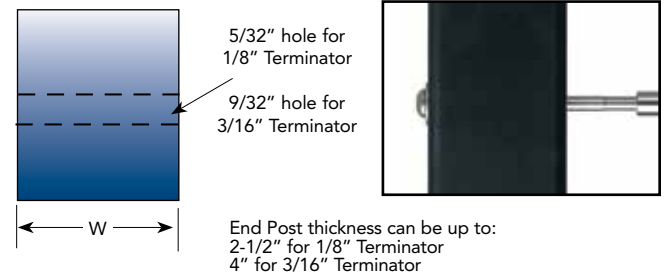

Adjustable Allen Head Screw



Part #80-101-1 for 1/8" Deck Toggle Terminator

Turnbuckles



University of Tennessee at Chattanooga
Cable Fabricator: Al-Co Fabrications Inc. - Rosville, GA



Toggle Jaws

Classic Toggle Jaw



Machine Swage

CAT. NO.	WIRE SIZE	LENGTH	PIN SIZE
25-314	1/8"	3-3/16"	1/4"
25-316	3/16"	3-5/16"	1/4"
25-318-7*	1/4"	3-1/4"	5/16"
25-308	1/4"	3-3/4"	3/8"

*swage with 7/32" die

Hand Crimp

CAT. NO.	WIRE SIZE	LENGTH	PIN SIZE
26-415	1/8"	3-3/16"	1/4"
27-415	3/16"	3-5/8"	1/4"

Johnson Hand Crimp Tool must be used to attach fittings to cable. See page 38.

Smooth Line Toggle Jaw



Machine Swage

CAT. NO.	WIRE SIZE	LENGTH	PIN SIZE
25-600	1/8"	3-7/8"	1/4"
25-602	3/16"	3-7/8"	1/4"
25-604*	1/4"	4-1/2"	5/16"

*swage with 7/32" die

Hand Crimp

CAT. NO.	WIRE SIZE	LENGTH	PIN SIZE
26-600	1/8"	3-7/8"	1/4"
27-600	3/16"	3-7/8"	1/4"

Johnson Hand Crimp Tool must be used to attach fittings to cable. See page 38.

Button Terminals

Classic Button Terminal

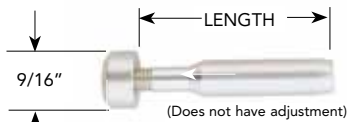

Machine Swage

CAT. NO.	WIRE SIZE	LENGTH	THREAD
25-304-5F	1/8"	1-3/4"	1/4" X 28
25-306-5F	3/16"	2-1/8"	1/4" X 28
25-308-7-5F*	1/4"	2-1/2"	5/16" X 24

*swage with 7/32" die

Hand Crimp

CAT. NO.	WIRE SIZE	LENGTH	THREAD
26-405-5F	1/8"	2-3/8"	1/4" X 28
27-405-5F	3/16"	2-3/4"	1/4" X 28

Johnson Hand Crimp Tool must be used to attach fittings to cable. See page 38.

Smooth Line Button Terminal

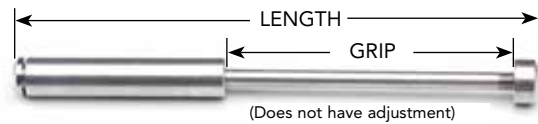

Machine Swage

CAT. NO.	WIRE SIZE	LENGTH	GRIP	THREAD
25-610-F	1/8"	6-1/4"	3-1/2"	1/4x28
25-612-F	3/16"	6-1/4"	3-1/2"	1/4x28
25-614-LF*	1/4"	8"	5-1/2"	5/16x24**

*swage with 7/32" die

Hand Crimp

CAT. NO.	WIRE SIZE	LENGTH	GRIP	THREAD
26-610-F	1/8"	6-1/4"	3-1/2"	1/4x28
27-612-F	3/16"	8-1/4"	3-1/2"	1/4x28

Johnson Hand Crimp Tool must be used to attach fittings to cable. See page 38.

Deck Terminals

Classic Deck Terminal

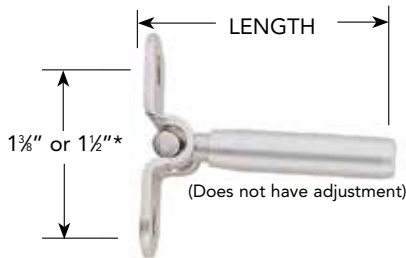

Machine Swage

CAT. NO.	WIRE SIZE	LENGTH	HOLE SIZE
25-314-1T	1/8"	2-1/8"	1/4"
25-316-1T	3/16"	2-1/8"	1/4"
25-318-1T*	1/4"	3-1/4"	5/16"

*swage with 7/32" die

Hand Crimp

CAT. NO.	WIRE SIZE	LENGTH	HOLE SIZE
26-415-1T	1/8"	2-3/4"	1/4"
27-415-1T	3/16"	3"	1/4"

Johnson Hand Crimp Tool must be used to attach fittings to cable. See page 38.

Smooth Line Deck Terminal

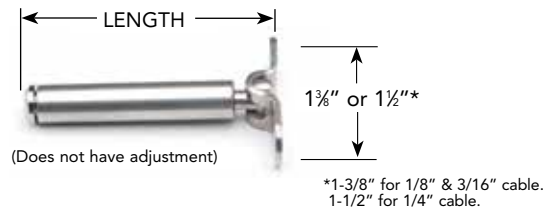

*1-3/8" for 1/8" & 3/16" cable.
1-1/2" for 1/4" cable.

Machine Swage

CAT. NO.	WIRE SIZE	LENGTH	HOLE SIZE
25-600-1	1/8"	3-1/4"	1/4"
25-602-1	3/16"	3-1/4"	1/4"
25-604-1*	1/4"	3-5/8"	5/16"

*swage with 7/32" die

Hand Crimp

CAT. NO.	WIRE SIZE	LENGTH	HOLE SIZE
26-600-1	1/8"	3-1/4"	1/4"
27-600-1	3/16"	3-1/4"	1/4"

Johnson Hand Crimp Tool must be used to attach fittings to cable. See page 38.

Ball Terminals

Classic Ball Terminal

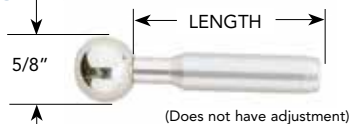

Machine Swage

CAT. NO.	WIRE SIZE	LENGTH	THREAD
25-304-5B	1/8"	1-11/16"	1/4" X 28
25-306-5B	3/16"	2-1/8"	1/4" X 28
25-308-7-5B*	1/4"	2-1/2"	5/16" X 24

*swage with 7/32" die

Hand Crimp

CAT. NO.	WIRE SIZE	LENGTH	THREAD
26-405-5B	1/8"	2-3/8"	1/4" X 28
27-405-5B	3/16"	2-3/4"	1/4" X 28

Johnson Hand Crimp Tool must be used to attach fittings to cable. See page 38.

Smooth Line Ball Terminal



Machine Swage

CAT. NO.	WIRE SIZE	LENGTH	GRIP	THREAD
25-610-B	1/8"	6-1/8"	3-1/2"	1/4" x 28
25-612-B	3/16"	6-1/8"	3-1/2"	1/4" X 28
25-614-LB*	1/4"	8"	5-1/2"	5/16" x 24**

*swage with 7/32" die

Hand Crimp

CAT. NO.	WIRE SIZE	LENGTH	GRIP	THREAD
26-610-B	1/8"	6-1/8"	3-1/2"	1/4" x 28
27-612-B	3/16"	6-1/8"	3-1/2"	1/4" x 28

Johnson Hand Crimp Tool must be used to attach fittings to cable. See page 38.



ALL T-316 MARINE GRADE STAINLESS!

Nuts & End Caps



Acorn Nuts



Stainless Nuts



Washer Cap Nut



Button Ends



Solid Buttons
(supplied with turnbuckles)



Ball Ends
(supplied with turnbuckles)

#	CAT. NO.	THREAD
1	35-600	1/4"-28
1	35-599	5/16"-24
2	60-603	5/16"-24 x 9/16"
2	35-605FS	5/16"-24
2	35-607FS	3/8"-24

#	CAT. NO.	THREAD
2	35-603	1/4"-28
3	35-603WN	1/4" x 28
3	35-605WN	5/16" x 24
4	60-602	1/4"-28 x 9/16"
4	60-603	5/16"-24 x 9/16"

#	CAT. NO.	THREAD
5	60-602-D	1/4"-28
5	60-603-D	5/16" x 9-1/16"
5	60-643-D	5/16" x 5/8"
6	60-614-B	1/4"-28 x 5/8"
6	60-615-B	5/16"-24 x 5/8"

Angle Standoffs



FOR USE WITH THESE PRODUCTS	30 DEGREE STANDOFF ON A FLAT SURFACE	30 DEGREE STANDOFF ON A PIPE	35 DEGREE STANDOFF ON A FLAT SURFACE	90 DEGREE STANDOFF ON A PIPE
1/4-28 Thread Terminals	60-604*	60-605*	60-604-35*	60-616*
5/16-24 Thread Terminals	60-604**	60-605**	60-604-35**	60-6016**
3/8-24 Thread Terminals	60-644	N/A	N/A	N/A
Terminal Tuners	60-614	60-615	N/A	60-616
1/8" Quick Connects	60-644	N/A	N/A	N/A
3/16" & 1/4" Quick Connects	F60-644-916	N/A	N/A	N/A
1/4-28 Thread w/ Washer Nuts	N/A	N/A	F60-644-35	N/A
All Button Ends	60-604	60-605	60-604-35	N/A
Terminators 3/16" 1/4"	60-604 60-604 w/o washer	60-605 60-605 w/o washer	60-605-35 60-605-35 w/o washer	60-616 60-616 w/o washer

* Use with 60-601-SO Conversion Washer

** Use with 60-603-SO Conversion Washer

1/4" Security Bolt



CAT. NO.	DESCRIPTION
PB-4-16	1/4" x 1/2"

Protector Sleeve



CAT. NO.	DESCRIPTION
SSPS-4-6	For 1/8" & 3/16" cable

For wood compression fit drill 1/4" hole.
Will not accept cable end fittings.

* For Smooth Line sleeves, see page 8 & 16 in Marine Catalog.

Conversion Sleeves



CAT. NO.	DESCRIPTION
36-610	1/8" to 3/16" Machine Swage
36-611	1/8" to 3/16" Hand Crimp

Washers



CAT. NO.	DESCRIPTION
60-601-SO	1/4" Conv.
60-603-SO	5/16" Conv.
60-102	1/4" Washer
60-103	5/16" Washer
60-104	3/8" Washer

Note: Conv. Washer fits in the counterbore of standoffs to center smaller sizes.



Nylon Bushings/ Grommets

CAT. NO.	DESCRIPTION
BPG-2003	Drill size: 1/4", For 1/8 Cable
BPG-2020	Drill size: 3/8", For 3/16" Cable



More replacement parts can be found on pages 11, 12 and 20 of the Marine Catalog.



QuickConnect-SS™ Fittings

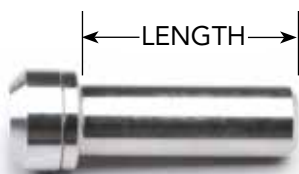

Shown with Bevel cap



Shown without cap



Part # JQFRT
Releases installed QuickConnect fittings.

QuickConnect-SS™ fittings with special one-way jaws automatically grab and lock on to the cable without any tools. Simply slide them on, pull the cable tight, trim the excess and finish with an end cap.

Best if used with Washer Cap Nut and Threaded Terminal...

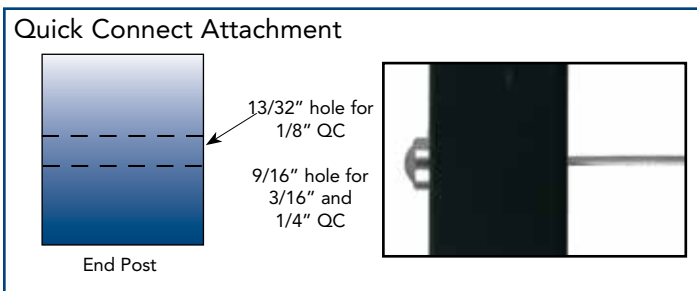

Complete Cable Assembly (Example)



QuickConnect Fittings Require No Attachment Tools!

CAT. NO.	WIRE SIZE	LENGTH	DIAMETER
FQC 18	1/8"	1-1/4"	9/64"
FQC 316	3/16"	1-7/8"	17/32"
FQC 14	1/4"	1-7/8"	17/32"

(This end requires Machine Swage or Hand Crimp fitting).

Washer Cap Nut



The Washer Cap Nut allows the installation of a Cap on a conventional threaded terminal mirroring the Cap on a QuickConnect fitting. The Caps are available in stainless steel and plastic in a variety of colors. Please see below for cap options.

CAT. NO.	THREAD SIZE
35-603WN	1/4"X28
35-605WN	5/16"X24



Stainless Steel & Colored Caps (Polyethylene)

Stainless Steel and Colored Caps snap on to QuickConnect fittings and Washer Cap Nuts with no tools. They provide a clean finished look. Stainless Steel Caps are offered in Crown, Bevel and Dome styles. Colored Caps come in Dome style in Black, White, Gray, Brown, Silver, Taupe, Bronze, Green and Cream Polyethylene.

CAT. NO.	STYLE	MATERIAL
SSDC	Dome	Stainless Steel
SSCC	Crown	Stainless Steel
SSCHC	Bevel	Stainless Steel
QCPC (color)	Dome	Plastic





Terminal Tuner Finish Plate / Drill Guide



The new Terminal Tuner Finish Plate allows for easy countersinking of Bevel Terminal Tuners or flip it over for use with Button or Ball Terminal Tuners on wood posts. It can also be used singularly as a drill guide. This finish plate makes it easy to have a simple custom look of Terminal Tuners where they are not easily used with wood posts. The finish plates are made from Type 316 Stainless Steel and have a tough marine grade tumbled finish. The holes have clearance for 3/8" fittings and are beveled on one side for the Bevel Terminal Tuner spaced at 3 inches for a total of eleven holes. The plate is 3/16" thick and 1 1/2" wide by 33" long. For use with 1/8" & 3/16" Terminal Tuners.

Part # TTFP33

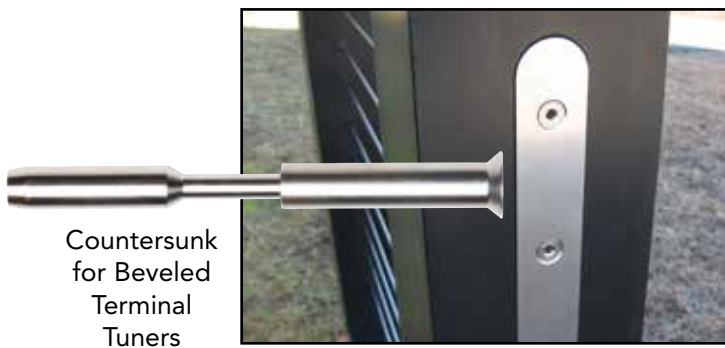
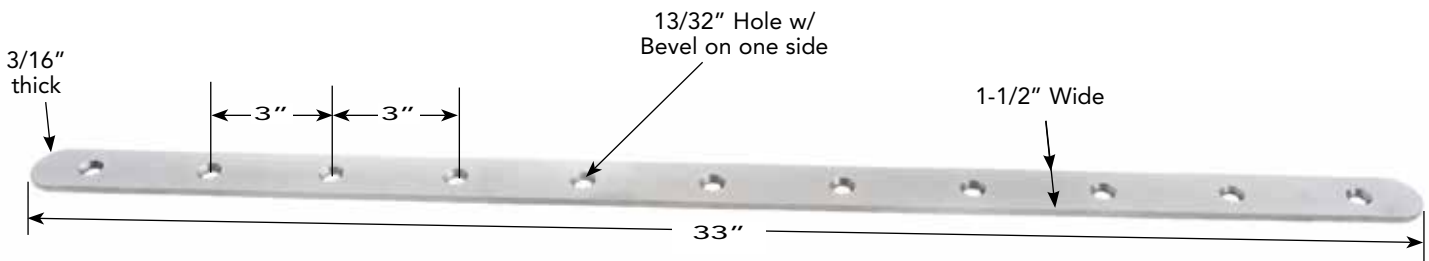
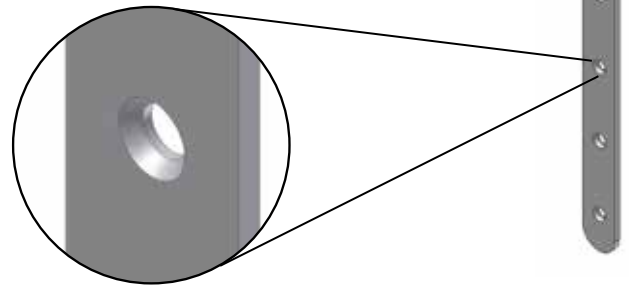



Vertical Rods

Johnson's 1/4" stainless steel vertical rods are an excellent choice for vertical railings. The 1/4" rods need to be placed every three inches to satisfy code requirements. Held in place at the top with Johnson's Button End Cap, the rod is tensioned at the bottom with 1/4" x 28 thread. A wrench flat is provided at the bottom to rotate the rod tight. The rods can be threaded directly into the railing or held with a conventional nut and washer. A steel fabricator must provide a framework and cap rail for the rods. Additional sizes are available, please call for more information.



Halona Blow Hole - Oahu, HI
Cable Fabricator: Art Nelson Sailmakers, Honolulu

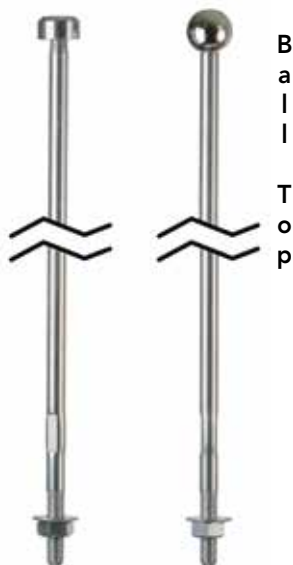

Framework Requirements

End posts and corners need to be made from the following minimums:

- Round Pipe 1-1/2" ID Schedule 80
- Square Tube 2" X 2" X 1/4" Wall
- Angle Iron 2" X 2" X 1/2"
- Flat Bar 2" X 1"

Top and bottom horizontal channels to support rods need to be made from:

- 1" x 1" x 1/8" Channel and supported every 4 feet by the end posts listed above.
- 3/4" OD x 1/4" Pipe center post needs to be placed every 2 feet.

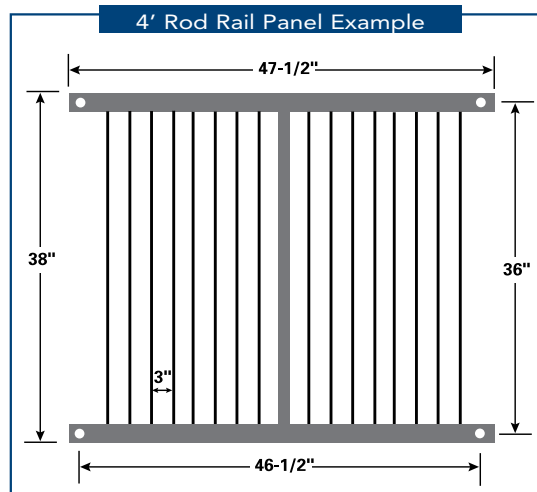

Please Note: Johnson Architectural Hardware does not make framework. Framework needs to be made by a steel fabricator



Glass Shelf Fittings

The Glass Shelf Fitting works on 1/8" wire and 3/8" thick glass. The Glass Shelf Fittings make it easy to make glass shelves with cable and glass for a unique look. Johnson does not sell glass.

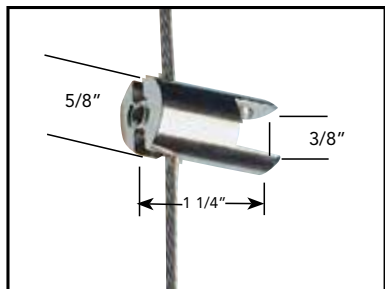

CAT. NO.	WIRE SIZE	GLASS SIZE
62-100	1/8"	3/8"



Glass Shelf Fitting used on Bar Shelf.



Glass Shelf Fitting with 1/8" Deck Toggle Terminator.

CableTrellis™ Cross Clamp

The CableTrellis™ Cross Clamps for 1/8" cable are available in Stainless Steel and Hard Anodized Aluminum. The CableTrellis Cross Clamps allows 90° intersections to be made with cable suitable for garden trellises or decorative cable assemblies. Choose Stainless Steel or Colored Caps to accentuate your design.

CAT. NO.	WIRE SIZE	MATERIAL
62-500	1/8"	Stainless Steel



Stainless Steel Cross Clamps for 1/8" wire.



"Smart Catch" Stainless Spring-Loaded Door Latch

This unique Door Latch is a design that not only serves as a door stop, but holds the door in place against a wall. The unique foot lever releases the spring-loaded bumper and swings the door free. Two styles are available — straight or pivot, for non-parallel closing doors.

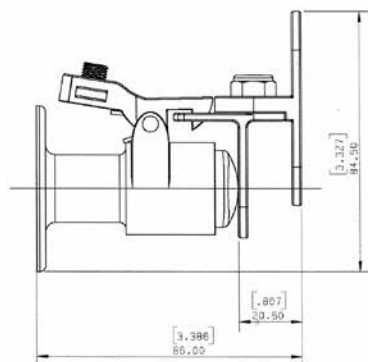

CAT. NO.	DESCRIPTION
48-800	"Smart Catch" Door Latch - Straight
48-801	"Smart Catch" Door Latch - Pivot



Frequently Asked Questions

Professional Tension Gauge for 1x19 Cable Railing

Johnson's new Professional Tension Gauge for 1x19 Cable Railing is designed to measure the cable tension of 1/8", 3/16" and 1/4" 1x19 cable. This gauge takes the guess work out of cable railing setup. Made from anodized aluminum, the gauge is easy to use and compact. A must for the toolbox of anyone installing cable rails.



Cable Range:
1/8", 3/16" & 1/4"

Dimensions:
11" x 5-1/2"

Tension Range:
200 lbs - 400 lbs

Made in USA

CAT. NO # 53-300



Hand Crimping Tools & Cutters

Hand Crimp fittings are attached to the cable with a Johnson-made Hand Crimp Tool model #53-210 (not shown) or #53-215. Hand Crimp fittings should not be confused with Nicopress fittings. Nicopress fittings have sleeves that are made from soft copper alloy and compress very easily. Other crimping tools will not compress Johnson stainless steel fittings properly. Only use a Johnson approved tool.



1. Our Lever Type Tool has two cavities for 1/8" and 3/16" Hand Crimp fittings. This is a good production tool for the dealer.

Lever Type Tool	Cat. No. 53-215
-----------------	-----------------

2. Our Felco Cable Cutter will give you a clean, crisp cut through 1/4" sized cables. Swiss made

Felco Cable Cutter	Cat. No. 53-220
--------------------	-----------------

3. Our Larger Felco Cable Cutter cuts cable through 3/8."

Larger Felco Cable Cutter	Cat. No. 53-222
---------------------------	-----------------

Our Largest Felco Cable Cutter cuts cable through 5/8".

Largest Felco Cable Cutter	Cat. No. 53-224 (not shown)
----------------------------	--------------------------------



Portable Hydraulic Press Swager - by Johnson

Swaging range:
1/8" - 3/16"
Dimensions:
L 7"
W 5 1/2"
H 13"
Shipping Weight:
50 lbs

Made in USA



Johnson's New Portable Hydraulic Press Swager is a true hydraulic press. This swager presses the fittings onto the cable. All that is required to run this swager is 100 psi of compressed air. The air is coupled to an air over hydraulic foot switch. At 50 lbs. this swager is very portable. An electric over hydraulic pump is also available for 110v. Made in USA. Not rated for mil-spec fittings.

Locoloc® Bench Swager - Type II

Swaging range:
1/16" - 3/8"
Dimensions:
L 12"
W 9"
H 12"
Shipping Weight:
175 lbs (manual)
275 lbs (power)

Made in USA
Makes Mil-Spec Swages

Power
Operated
#M2-P



*Call for more
information.*

Manual
Operated
#M2

WireTeknik™ Roller Swagers

Made in Sweden
Makes Mil Spec Swages

NOTE: Cannot swage Smooth Line Turnbuckles, Blind Thread Terminal Tuners and 1/8" Terminator Turnbuckles. Adapter needed for deck toggles.

A100

Swaging range:
1/16" - 3/16"
Dimensions:
L 19 3/4"
W 11 3/4"
H 4"
Shipping Weight:
50 lbs

(A200 shown with optional PUH-01 Hydraulic Pump powered by cordless drill)



A200

Swaging range:
1/16" - 5/16"
Dimensions:
L 17"
W 11"
H 4 3/4"
Shipping Weight:
100 lbs

A270

Swaging range:
3/32" - 1/2"
Dimensions:
L 37"
W 15 3/8"
H 6 9/32"
Shipping Weight:
150 lbs

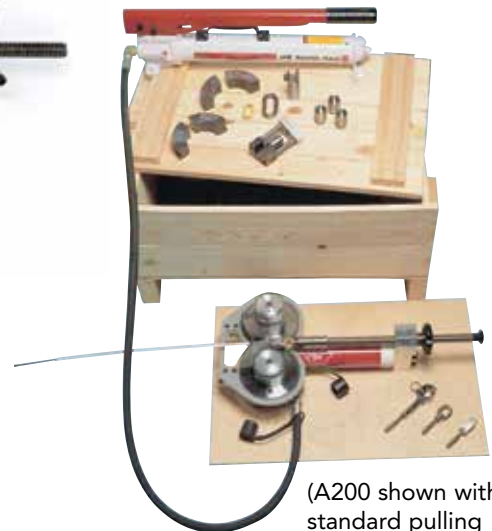

(A200 shown with standard pulling devices and hand pump. Johnson fittings not included.)