

## **J. Sussman, Inc.**

109-10 180<sup>th</sup> Street  
Jamaica, NY 11433  
Tel: (718) 297.0228  
Fax: (718) 297.3090  
E-mail: sales@jsussmaninc.com  
Web site: www.jsussmaninc.com

## **Metal and Glass Curving**

Since 1906, J. Sussman, Inc. has been a pioneer in the advancement of metal bending technology. Our innovative processes have resulted in many thousands of highly successful projects that continue to stand the test of time. As a result of our metal curving experience, it was natural for J. Sussman, Inc. to add glass curving to our extensive metal and glass services.

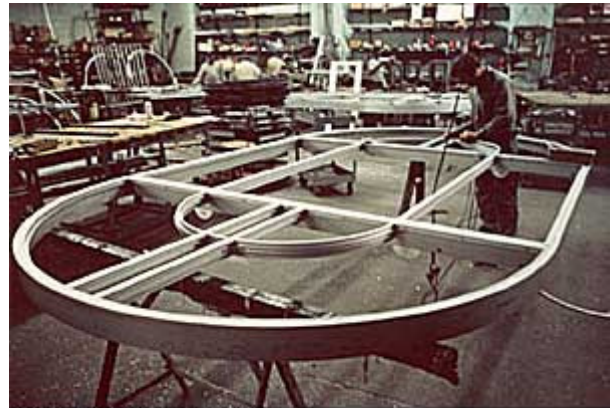

Custom Aluminum Bending

Today, J. Sussman, Inc. is a full service supplier of both curved metal and curved glass. This assures you of a single source responsibility for all your glass and metal curving needs. In addition, we also offer completely engineered systems for windows, skylights, sunrooms, storefronts and other architectural metal and glass specialties. These systems have been designed for the most accurate and cost effective curving - giving our customers a tremendous competitive advantage when curving is required.

Of course, we also have the ability to curve most other architectural metal and glass systems and have done extensive curving of handrails, lighting fixtures, signs, shower doors, furniture, transportation parts and a host of other products for numerous industries.

### **Unparalleled Service**

As a supplier and fabricator we can provide faster and more complete service than is offered anywhere. Utilizing the most efficient computerized curving equipment, together with our "state of the art" 80,000 square foot manufacturing facilities, J. Sussman, Inc. can offer a service time of one to two weeks for most orders.

We can either curve your material or, with over 1 million pounds of aluminum plus a large supply of glass in stock, we can often supply the material and save you delivery costs and shipping time. In addition, our years of experience in metal curving for leading metal suppliers has enabled us to accumulate a large inventory of tooling which will also minimize your costs and delivery time.

Technical assistance and price quotations are provided by our highly trained engineering and estimating staff with the aid of the most advanced equipment. Computerized shop drawings and engineering can be supplied.

### **Versatility And Capability**

With our various methods of metal curving, J. Sussman, Inc. has the ability to curve virtually all metals to an unlimited variety of shapes and sizes. No job is too large or small. We regularly curve aluminum angles, channels, rectangular and round tubes, pressure plates and caps, thermal break extrusions and brake metal shapes. They can be formed to circles, segments and ovals and can usually have tangents when required. In addition to aluminum we can curve brass, steel, bronze and other metals.

Our glass curving capabilities are constantly increasing as we strive to have the most complete glass and metal curving services in the industry. In addition to curving glass up to 3/4" thick we laminate and insulate as well. When curved metal is required for our curved glass, we carefully check the fit; this gives us full control over the accuracy and quality of the job. Having only one full source curved metal and glass supplier also saves precious time and is more economical.

As a leading architectural metals and glass manufacturer, J. Sussman, Inc. has the capabilities of complete fabrication. Our experience in fabricating curved materials often makes the job more cost effective and accurate when we do the fabrication. It is often advantageous for a J. Sussman, Inc. engineered system to be submitted for the curved part of the job.

## METAL CURVING

The following information should be specified when placing orders or requesting quotations:

### 1. Material to be Curved

Include the manufacturer and part number, if any, as well as a cross section detail with overall dimensions and thickness. Not all material can be curved satisfactorily; however, with our experience, we can suggest alternative solutions if necessary. In addition, our large inventory of channels, angles, tubes and specialized extrusions for the window, skylight and storefront trade can be used.

6063-T5 Aluminum alloy and temper is standard. We can curve almost any aluminum alloy and temper depending upon the limitations of the material. The alloy and type of metal should be specified. Thermal break material can usually be curved but J.Sussman, Inc. should be consulted prior to ordering.

### 2. Finish

For economy, it is preferable to have the metal curved with the finish on it. Extrusions can be curved in bronze and clear anodized as well as various painted finishes.

Most extrusions are curved prefinished with excellent results; however, we cannot guarantee the finish. Crazeing, peeling and blemishes may occur due to the nature of the curving process and the material and finish involved. A test curve is advisable if doubt exists.

### 3. Curving Axis

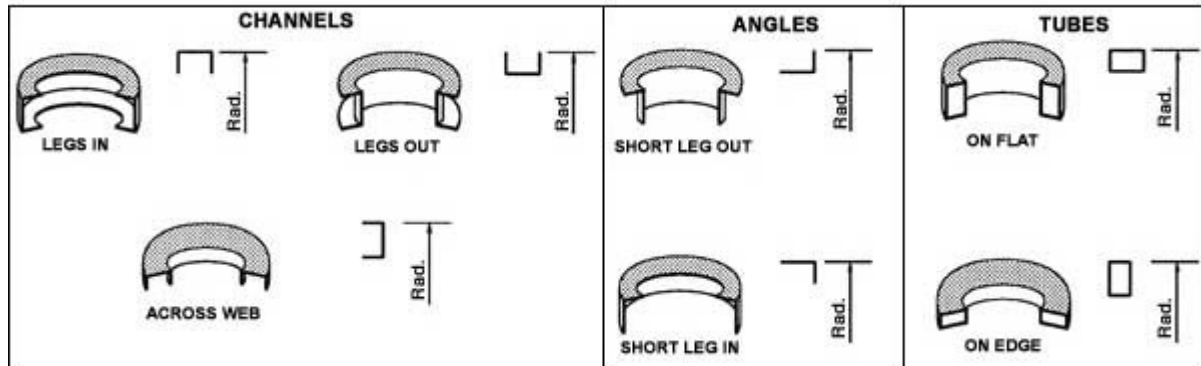

### 4. Shape and Radius

For full circles, half circles and quarter circles the outside radius need only be specified and a template will be supplied by J. Sussman, Inc (Figure a). For segments and gothics the outside radius, rise, width, and arc length should be supplied (Figures a and b).

When straight legs are required they must be tangent to the curve with no break (Figures c, d, and e). They are recommended when the legs are short. When the legs are longer, it often pays to mechanically fasten the straight leg on one side only. (Figures c and d).

An oval is wherever there are two or more different radii in the same shape. (Figure f and g). Because of the difficulty in bending ovals they may have to be made in two or more pieces and later spliced together by the customer. Templates must be supplied for ovals. For quotations, the rise, width, arc length and radii should be supplied.

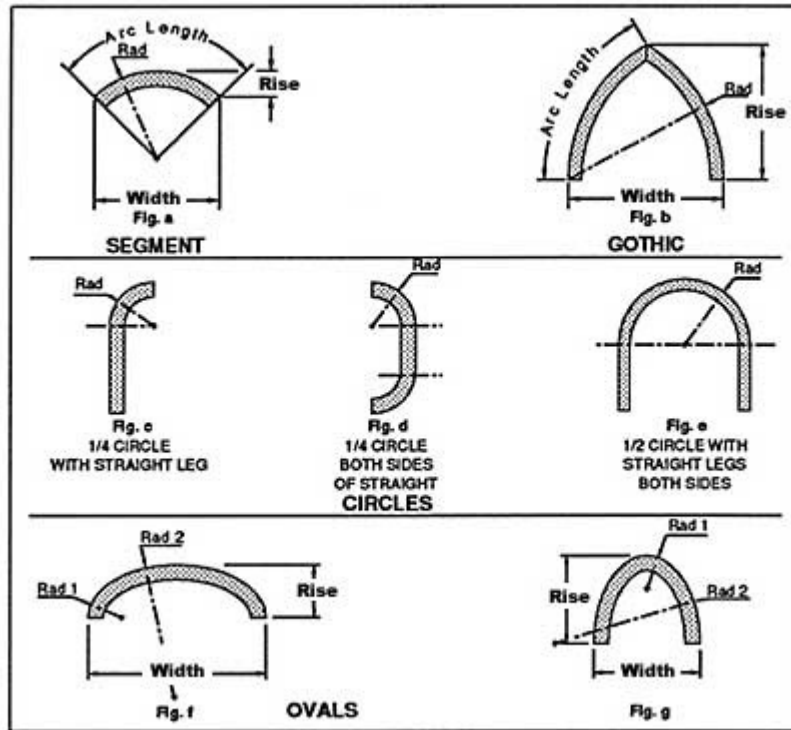

## 5. Quantity

Our diverse curving processes allow us to produce small quantities as well as large production runs. Similar extrusions and shapes should be combined where possible for quantity pricing.

When supplying your own material, be sure to consult J.Sussman, Inc. to determine proper size and quantity of lengths needed to accommodate waste and set up.

## 6. Additional Fabrication

Unless otherwise specified all curves will be shipped for field cutting, fitting and drilling. J. Sussman, Inc. has the facilities for complete fabrication when desired.

## GLASS CURVING

Please furnish the following information for pricing and ordering curved glass.

## 1. Measurements

In order to curve glass accurately we require the girth(B), height(E) and the radius(A). It is also a good idea to give us the chord(C) and rise(D) so we can double check your radius(A) and girth(B) dimensions mathematically. The chord(C) and rise(D) can also be used to determine the radius(A) if not known. This applies only if the shape contains one radius. Also, we must know if your measurements are to the inside of the curved glass or to the outside. The difference is the thickness of glass. If there are any doubts about the above, it is always good to send us a pattern if possible.

When there are flats (F), this measurement must also be given and included in the girth dimension. Flats must be tangent to the curve. J.Sussman, Inc. can bend glass with flats on one side or both sides of the curve.

For shapes with compound curves or ovals, a pattern is always required. Bending feasibility usually cannot be guaranteed until the actual pattern is observed by our technical staff.

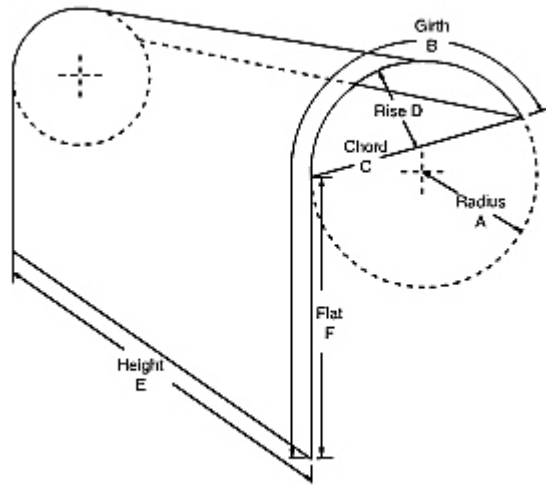

**BENT GLASS DIMENSIONS**

## 2. Thickness and Composition

Our "state of the art" curving facilities are capable of curving glass from 1/8" to 3/4" thick. In addition, we can laminate and insulate curved glass when required.

We regularly curve monolithic, laminated and insulated glass. For most architectural applications, 1/8", 3/16", and 1/4" thickness of glass are used with combinations of the above if laminating and insulating is required. The overall thickness must be specified as well as the glass combination for laminated and insulated glass.

It is important to use sufficient thickness glass to assure adequate strength of the curved unit. Our technical staff can help you determine the proper thickness and composition.

It is also the responsibility of the purchaser to make sure the glass meets all local and Federal building codes for the particular glass application. Laminated safety glass is usually required for sloped applications such as solariums and skylights. It may also be required depending upon proximity to doors and height from the ground as well as other circumstances.

## 3. Type of Glass

J. Sussman, Inc. has the capability to curve all types of uncoated glass whether clear or tinted. We also bend reflective and Low-E glass with a pyrolytic coating as well as spandrel and patterned glass. If there is a coating specify which side of the glass has the coating and identify which lites are tinted for laminated and insulated units.

## 4. Quantity

J. Sussman, Inc. is set up for small quantities as well as larger orders. Wherever possible quantities should be batched together by radii to minimize mold costs and set up charges.



Yeshiva of Spring Valley, Spring Valley, NY  
Ailamos, Bronx, NY