

THE

# INKAN

GROUP

08 41 00/INK  
BuyLine 7231



**Suspended Glass Wall Systems • Glass Canopies  
Kiosks, Entrances, Partitions • Glass Doors and Hardware  
Glass Balustrade • Spandrel Glass • Custom Metal and Sculpture**



# Swing, Bi-fold & Sliding Glass Door Systems

## THE INKAN GROUP

The harmonious achievement of architectural design and structural durability through the marriage of four distinct divisions, to offer an unlimited range of products and services in architectural metal and custom fabricated tempered glass:

## RDM GLASS SYSTEMS DIVISION

Custom designed glass doors, sliding glass entranceways, squash and racquetball glass backwalls, suspended glass walls, glass kiosks; all engineered to make the architect's vision a reality.

## INKAN CONTRACT DIVISION

Supply and installation, from engineering to finished structure, for suspended glass walls, office interiors, shopping malls, balustrade, ensuring complete control of operations from manufacture to installation.

## INKAN ARCHITECTURAL METALS DIVISION

Superior quality in material and workmanship, using virtually any metal from aluminum or stainless steel to brass, bronze or muntz bronze. For creation of custom door hardware, balustrade, fascia, wall panels, decorative sculptures.

## ULTRALITE TEMPERED GLASS DIVISION

Tempered and heat strengthened glass, clear or coloured, custom fabricated if required, in thicknesses from 4mm (5/32") to 19mm (3/4").

Ultralite Tempered Glass is manufactured using advanced processing and handling equipment and is tempered by a computerized, tong-free furnace. The result is maximum flatness and the highest quality of finish available.

Sandblasting, Engraving and Painting – Special lettering, logos, crests or designs can be incorporated on tempered glass to enhance the personal touch of doors, glass, push and pull hardware, or sidelites.



300 Series custom doors

## SPECIFICATIONS – DOORS

### DESIGN

As shown on drawings and series type

### MANUFACTURE

Centre hung or offset pivot doors as manufactured by InKan Limited, Brampton, Ontario Canada.

### GLASS

10mm (3/8"), 12mm (1/2"), 15mm (5/8"), or 19mm (3/4") Ultralite tempered clear glass, as manufactured by InKan Limited (CAN 2-12.1-79 National Standard). Tinted glass optional in 10mm and 12mm thickness.

### HARDWARE

Standard or custom hardware as manufactured by InKan Limited.

### METAL

Aluminum, Stainless Steel, Brass, Bronze.

### FINISHES

Mirror stainless steel  
 Brushed stainless steel  
 Mirror Brass  
 Brushed Brass  
 Mirror Bronze  
 Brushed Bronze  
 Clear and anodized aluminum  
 Aluminum finishes in hardcoat – medium bronze, black, champagne.

### CLOSERS

Floor Closers – Dorma BTS 80  
 – Universal HO  
 Overhead concealed closer  
 – Dorma RTS 88

### 100 Series:

Top and Bottom Rails

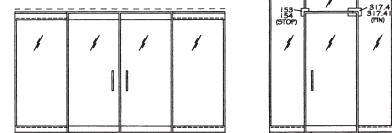

### 200 Series:

Patch Fittings

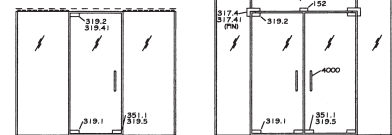

### 250 Series:

Combination Top Patch Fitting & Bottom Rail

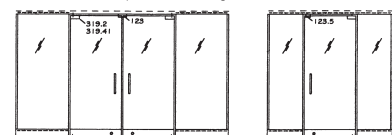

### 300 Series:

Rails Top & Bottom with Stiles

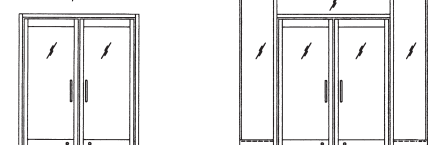

### 610 Series:

Bifold Door

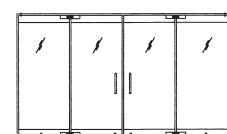

### 620 Series:

Accordion Door

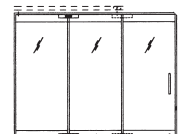



200 Series doors with Spider patch hardware



610 Series Bi-fold doors

TOP TRANSOM PIVOT 483 & TOP DOOR PIVOT 482

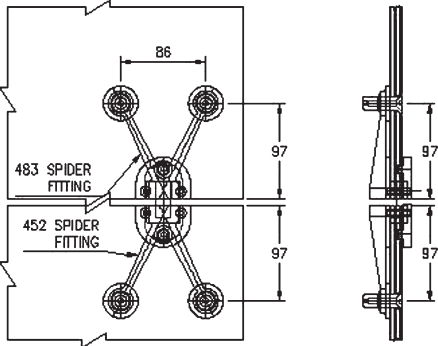

TOP TRANSOM PIVOT 483

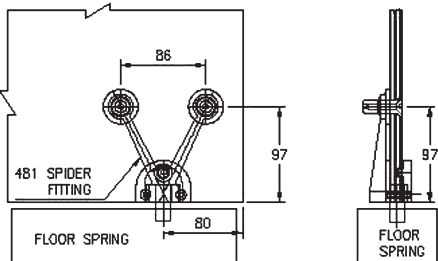

TOP DOOR PIVOT 482

SPIDER PATCH FITTINGS

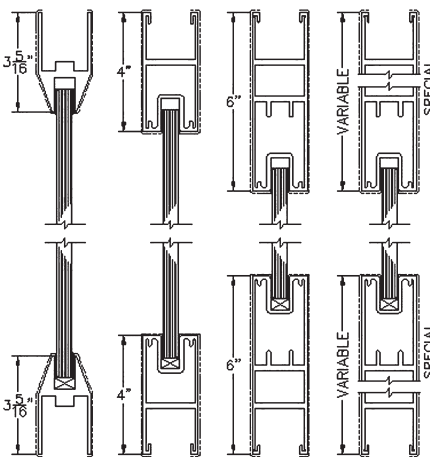
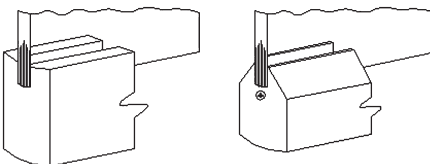
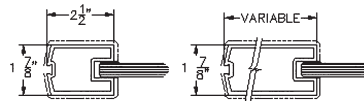

DOUBLETACK

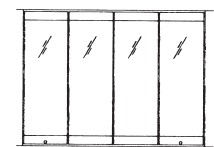

SINGLE TRACK

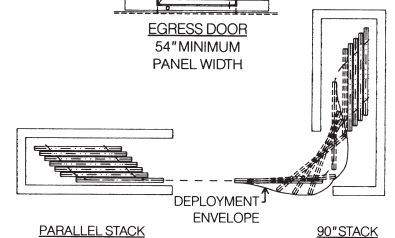
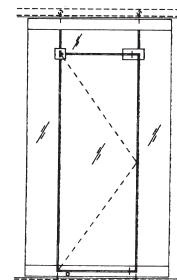
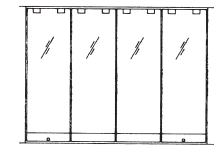



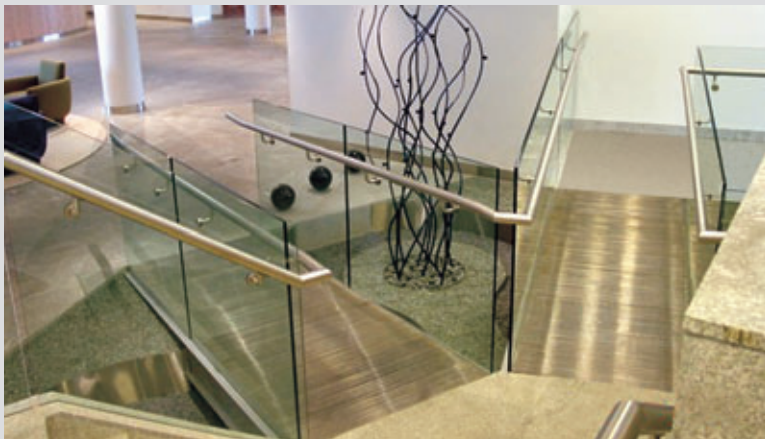

## Glass Balustrade



See our Structural Glass Wall Systems Catalogue – Section 08970/INK



InKan Limited  
14 Indell Lane, Brampton, Ontario, Canada L6T 3Y3  
Tel: (905) 793-4747 Fax: (905) 793-9367  
www.inkan.on.ca email: info@inkan.on.ca

SEE US IN       
DIRECTORY CATALOG FILES CD SWEETS.COM

TOLL FREE:  
U.S. (Midwest & East) 1-800-387-2481  
Canada (from Ontario) 1-800-387-2236