



*Closet and Wardrobe Doors*

## Marker Door

# Steel Marker Door with Magnetic Dry Erase Surface



Shown in Satin Gold, inset shown in Architectural Brown

- Durable 'Dry Erase' finish on stainless steel panel works great with dry erase markers
- Easy to adjust for out-of-square openings
- One piece 1-3/4" deep top track and integral fascia
- Low rise bottom track for minimal floor obstruction
- Adjustable top guides for greater vertical adjustment
- **Track:** Top and bottom track prefinished to match door
- **Colors:** Bright White, Vanilla, Architectural Brown, Black, Arctic Silver, Satin Gold, Bright Gold
- Limited lifetime warranty



**DUNBARTON Door and Entry Systems**

## Marker Door with Magnetic Dry Erase Panels

### MARKER DOOR SPECIFICATIONS

Provide Marker Door sliding wardrobe doors manufactured by Slimfold Corporation, Dothan, AL in the dimensions shown on the drawings and with the following attributes:

#### ARRANGEMENT

- Sliding doors shall consist of framed prefinished steel panels supported by adjustable bottom rollers and adjustable top guides that travel in a threshold track and top track respectively.
- Top track to be prefinished steel with an integral fascia that matches the stile and rail finish.
- The bottom track shall be prefinished steel to match door frame and shall not exceed 5/16" (8mm) in height for minimum floor obstruction.
- The bottom roller shall be free floating and provide a 1" (25mm) vertical adjustment. Marker Door rollers are factory installed and shall have plain bearing acetal wheels.
- The adjustable top guides shall be permanently fixed to the top connectors and fit snugly into the vertical openings in the top track.

#### FRAME

- The frame shall consist of prefinished roll-formed stiles and rails joined at each corner by positively retained, removable, unhandled, connectors that snap in place and contain preassembled rollers and guides.

#### PANELS

- Dry erase finished, steel panel.

#### FINISHES

Bright White, Vanilla, Architectural Brown, Black, Arctic Silver, Satin Gold, Bright Gold

No. Panels	Size	Door Width	Finished Opening Width
2	4'0"	24-1/8"	48"
2	5'0"	30-1/8"	60"
2	6'0"	36-1/8"	72"

**Required Finished Opening Height:  
6'8" (80-1/2") (2045mm)  
Finishing Open Width Tolerance +0" / -2"  
(+0mm/-51mm)**

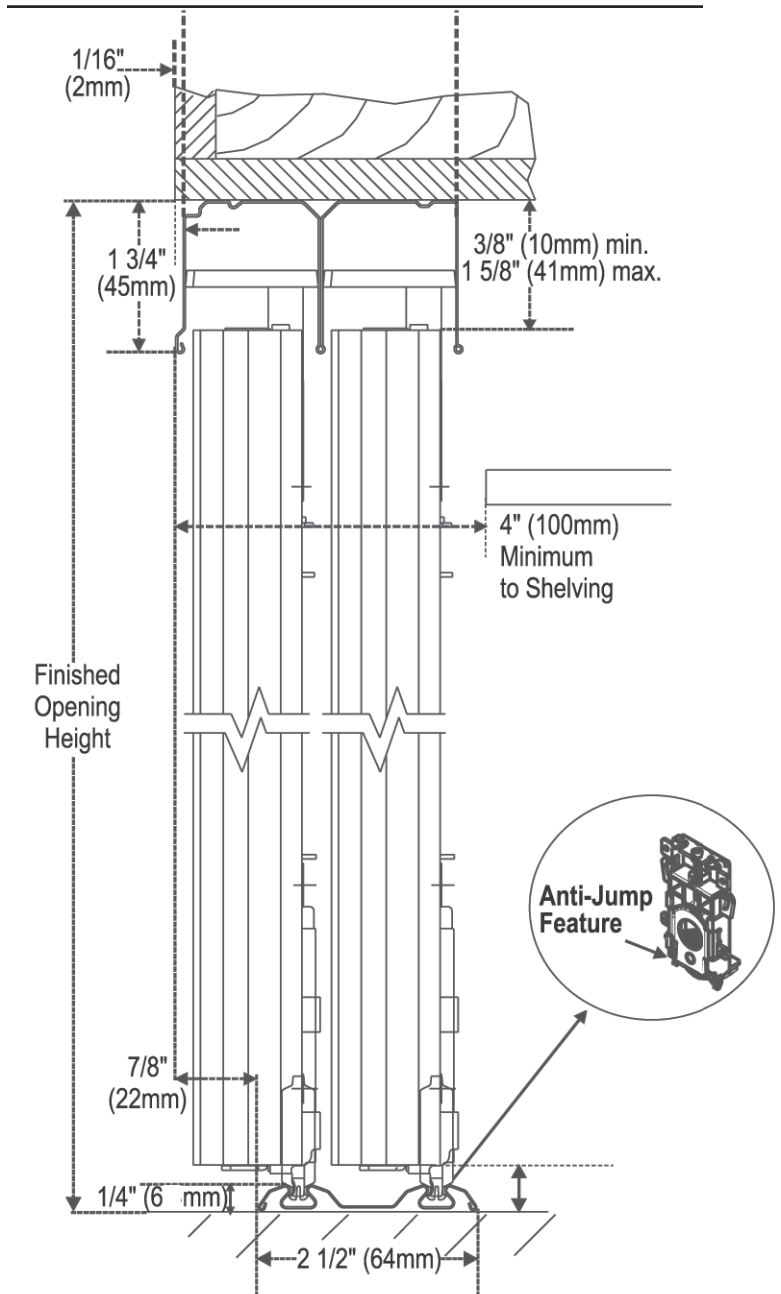

1101 Technology Drive | Dothan, Alabama 36303  
**800.633.7553** | 334.794.9184 (fax)  
 www.dunbarton.com | sales@dunbarton.com