



Walker® Infloor Systems

## AL241S-HB

### Bench/Table Top Service Fitting INSTALLATION INSTRUCTIONS

Installation Instruction No.: 1 003 194 – February 2003

Walker® electrical systems conform to and should be properly grounded in compliance with requirements of the current National Electrical Code or codes administered by local authorities.

All electrical products may present a possible shock or fire hazard if improperly installed or used. Walker electrical products may bear the mark as UL Listed and/or Classified and should be installed in conformance with current local and/or the National Electrical Code.

**IMPORTANT: Please read all instructions before beginning.**

#### Step 1

Determine configuration of receptacles in box and install short or long barrier as required (receptacles must be installed in the compartment containing the ground screw).

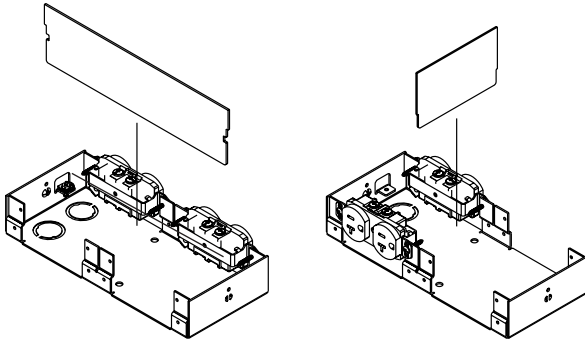

**NOTE:** Use long partition when receptacles are to be mounted adjacent to each other. Use short partition when receptacles are to be mounted back-to-back.

#### Step 2

Remove appropriate knockouts in power and communications compartments, then cut holes to correspond with these in the furniture surface on which the box will be mounted (holes must be large enough to accommodate conduit fitting being used). Pull 1/2" [12.7mm] or 3/4" [19.1mm] trade size flexible conduit through furniture surface and attach to base with conduit fitting. Attach base to furniture surface using appropriate fasteners. Wire receptacles according to NEC and local codes.

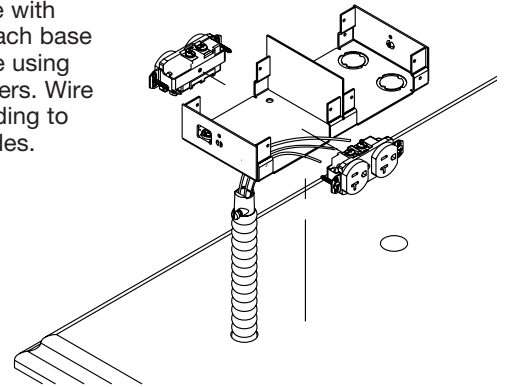

#### Step 3

Attach receptacles to base and attach faceplates using #6-32x1/2" screws provided in hardware bag.

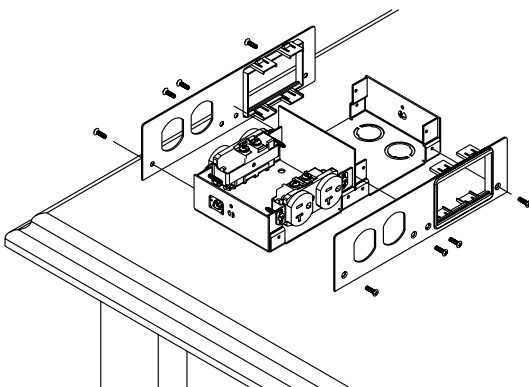

#### Step 4

Attach cover to box using #8-32x5/16" screws provided in hardware bag.

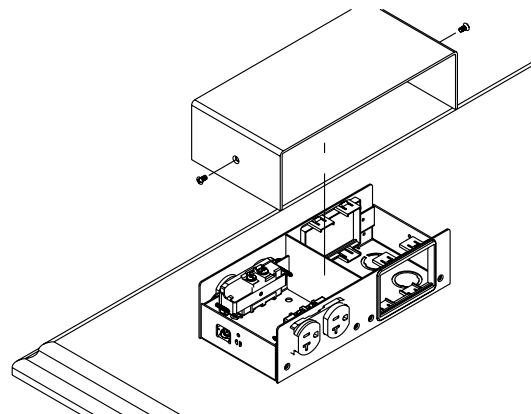

Walker® Infloor Systems

#### The Wiremold Company

U.S. and International:

60 Woodlawn Street • West Hartford, CT 06110

1-800-621-0049 • FAX 860-232-2062 • Outside U.S.: 860-233-6251

Canada:

850 Gartshore Street • Fergus, Ontario N1M 2W8

1-800-741-7957 • FAX 519-843-5980

