

WIREMOLD



RC9FFS, RC9AFFTC, 291-H/BTC, 292-H/BTC, RC91GHBTC, RC92GHBTC, and RC9CFFTC

INSTALLATION INSTRUCTIONS

Installation Instruction No.: 1 001 997 R2 - Updated July 2005

Wiremold Electrical Systems conform to and should be installed and properly grounded in compliance with requirements of the current National Electrical Code, Canadian Electrical Code or codes administered by local authorities.

All electrical products may represent possible shock or fire hazard if improperly installed or used. Wiremold electrical products are UL listed. Made for interior use only and should be installed in conformance with current local and/or the National Electrical Code.

IMPORTANT: Please read all instructions before beginning.

Suitable for use in air handling spaces in accordance with Sec. 300-22 (C) of the National Electrical Code.

Step 1. Layout and locate position of hole(s).

CAUTION: Holes shall be spaced a minimum of 2' [610mm] on center and not more than one hole per each 65 sq. ft. [6 sq. m] of floor area in each span.

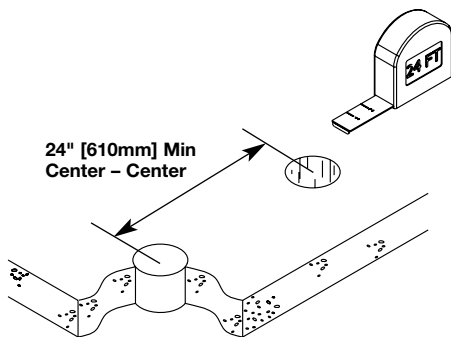

NOTE: Be certain to drill hole at least 4" [102mm] from any wall or pillar to leave enough room for poke-thru cover assembly.

Step 2. Core drill hole.

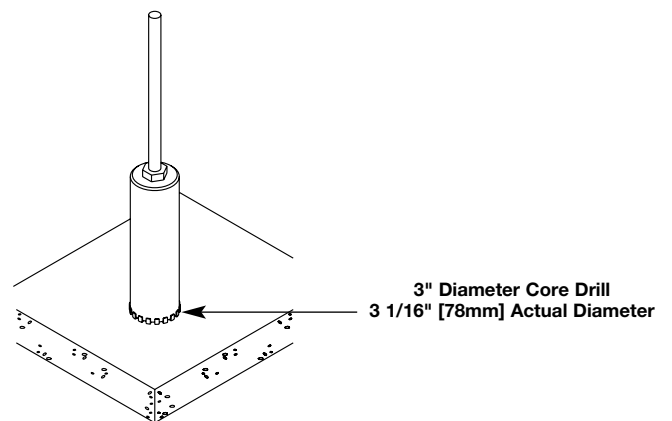

Step 3. Carpet Option.

Remove section from carpet using disposable plate or template.

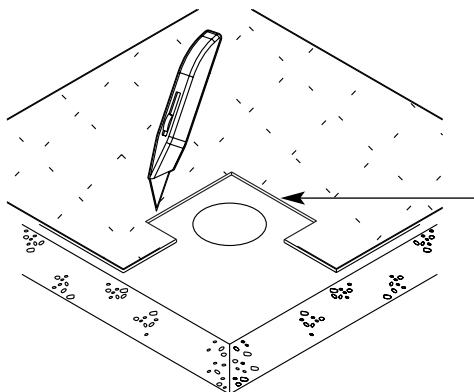

RC91GHBTC, RC92GHBTC,
291-H/BTC, 292-H/BTC
Style Service Heads
(Carpet Only)

RC9AFFTC, RC9CFFTC
6 1/2" [165mm] Diameter
Cutout (Carpet Only)

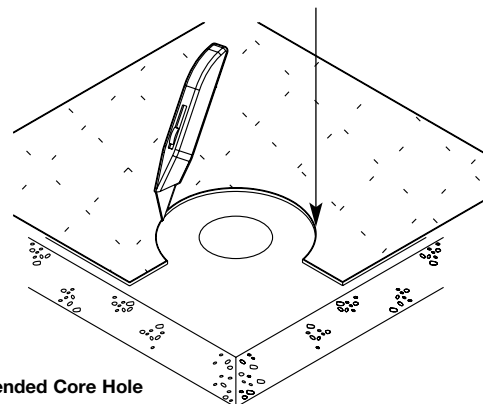

Make Concentric with Intended Core Hole

Step 4. Tile Option.

For RC9CFFTC and RC9AFFTC, cut a clearance hole in tile floor covering between 3 1/16" [78mm] and 4" [102mm] diameter.

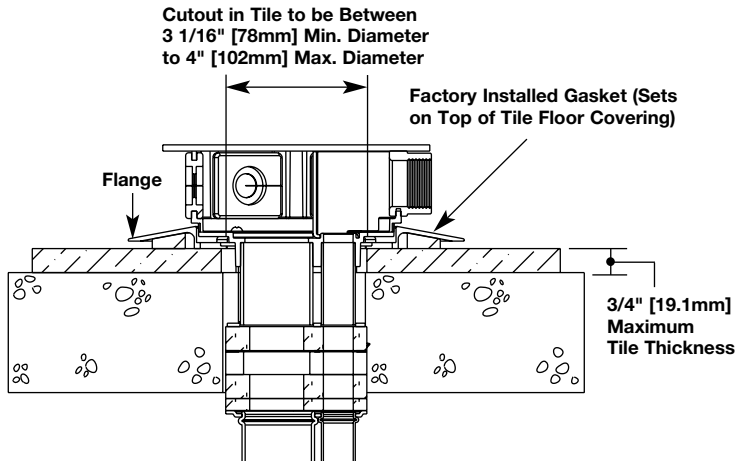

RC91GHBTC, RC92GHBTC, 291-H/BTC, 292-H/BTC Style Service Heads – Core Drill a 3" Diameter Through Both Tile and Concrete

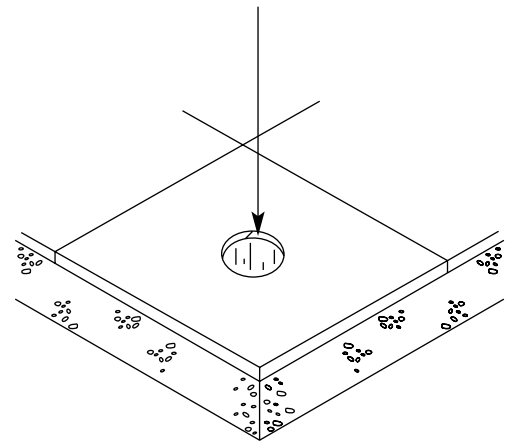

NOTE: If installing poke-thru cover assembly over grout line on tile floor covering, apply a silicon bead to underside of poke-thru flange or service head gasket.

Installing RC92GHBTC, RC91GHBTC, 291-H/BTC, and 292-H/BTC Style Service Heads:

Step 1. Install stem into core-drilled hole and then remove disposable plate. Retain the four screws for use when installing service head of choice.

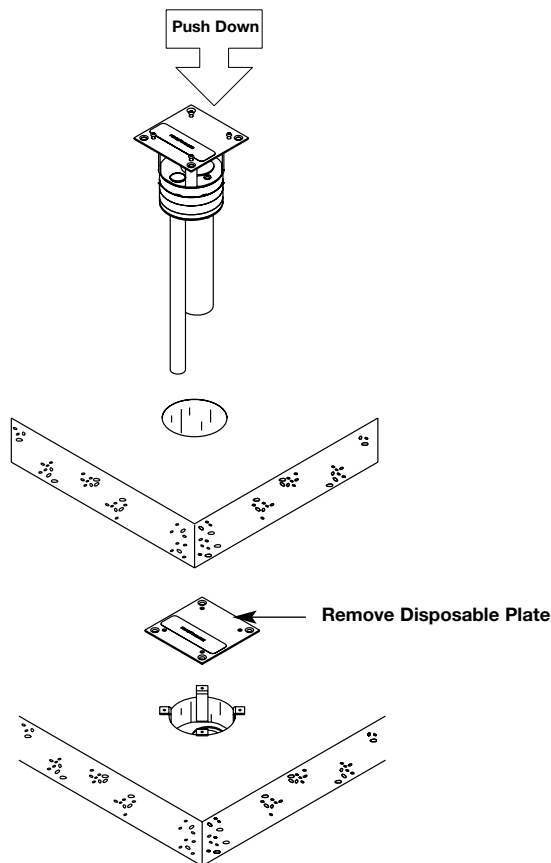

Step 2. Attach base to poke-thru stem using four #6-32 screws provided.

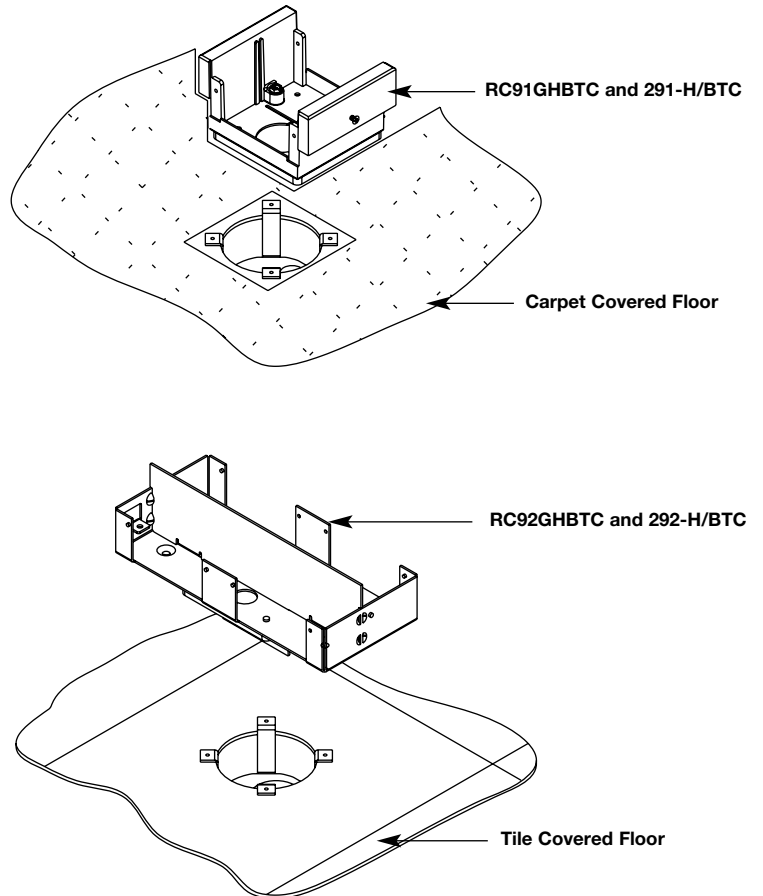

CAUTION: Poke-thru stem cannot be rotated after insertion.

Step 3. Install outlets, communication devices and corresponding faceplates.

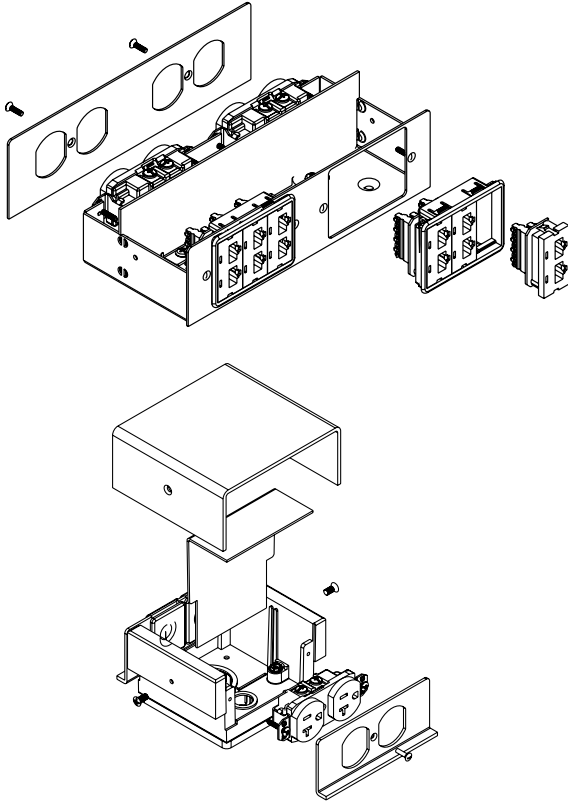

NOTE: If communication is required, connect necessary wires to communication jacks and snap into opening provided in faceplate.

Step 4. Attach cover plate using the #8-32 screws provided.

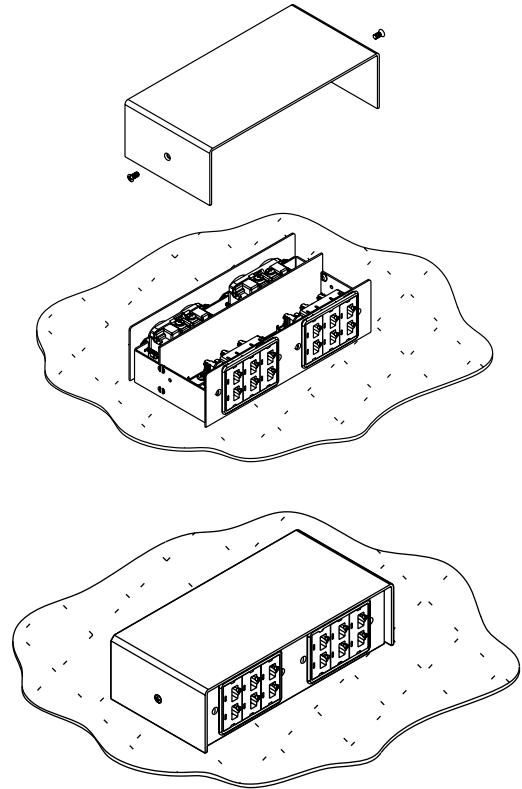

Completing Installation of RC9AFFTC and RC9CFFTC:

Step 1. Insert poke-thru stem into hole. Orientation of 1/2" trade size conduit should be directed towards power termination point.

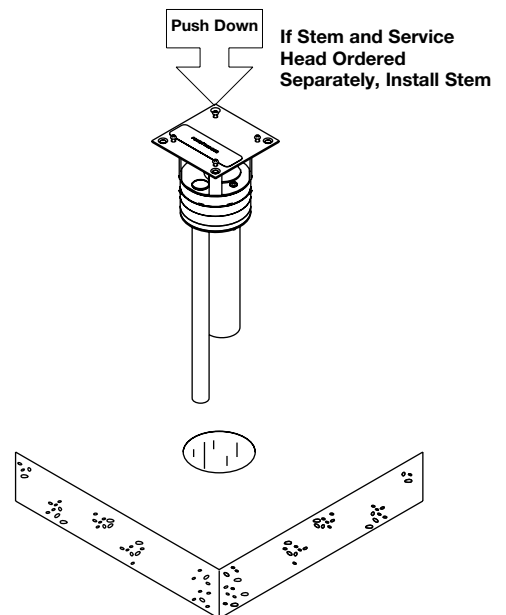
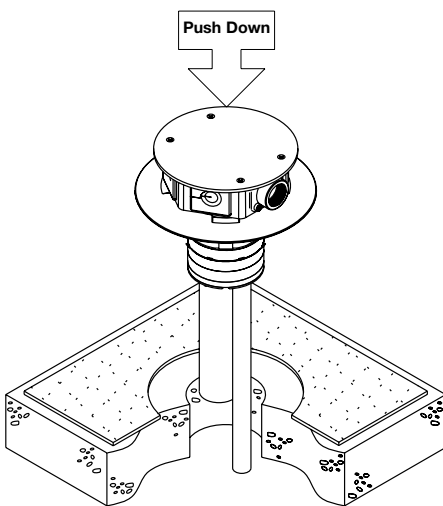

CAUTION: Poke-thru stem cannot be rotated after insertion.

Step 2: Remove disposable plate from poke-thru stem. Place trim flange and hex housing conduits and mounting holes. Install four #6-32 mounting screws. Make sure gasket is in place between the hex housing and trim flange.

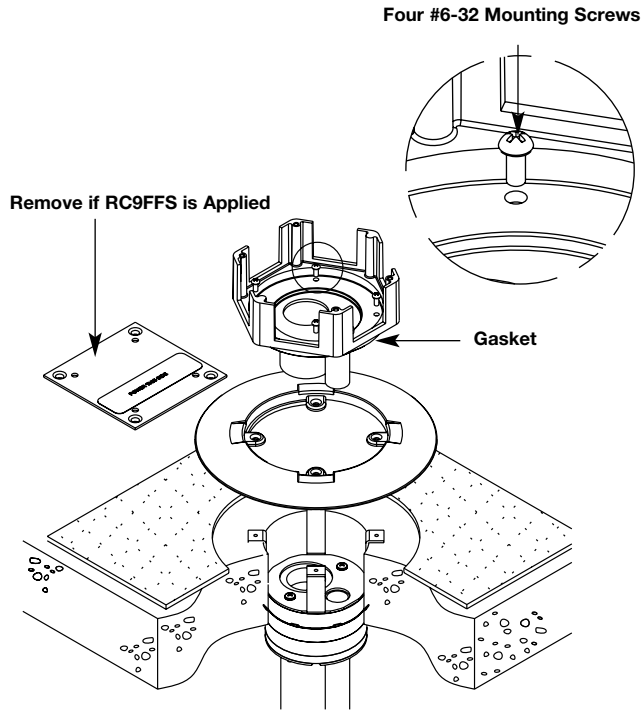

Step 3: Attach 1/2" trade size conduit fitting (not provided) to poke-thru power conduit. Connect to junction box (not provided). Connect 3/4" trade size flexible metal conduit and fitting to conduit adapter and insert into hex housing. Secure with #10-24 mounting screw. Complete installation per NEC and local codes

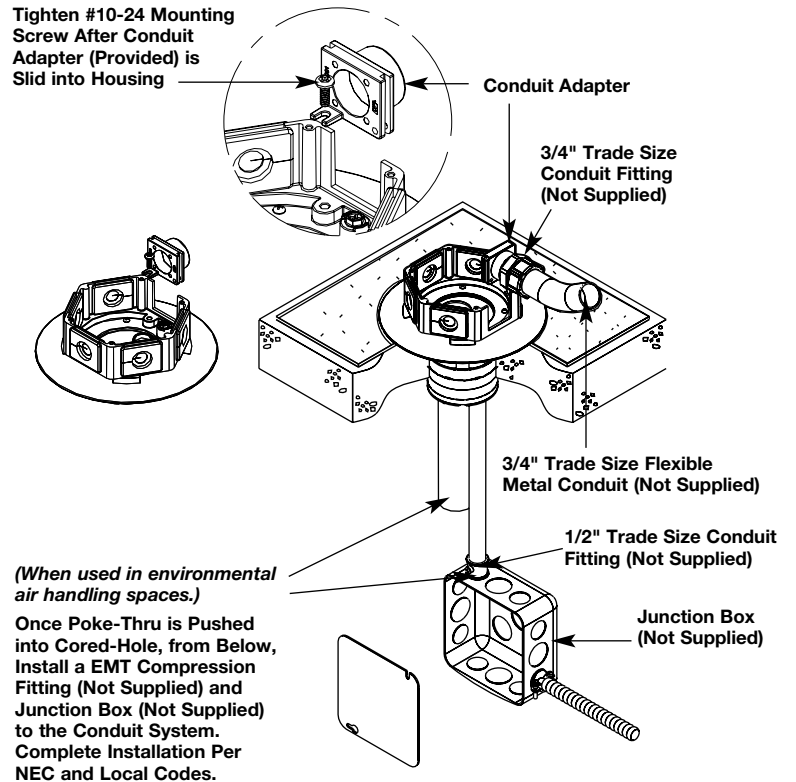

Step 4. Insert power barrier and secure with #6-32 barrier mounting screw. Attach cover with four #6-32 flathead screws.

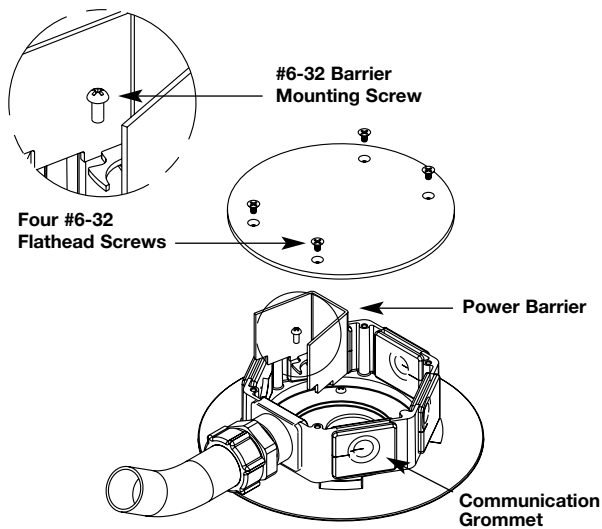

NOTE: Conduit Adapter in Step 3 may be used for connecting conduit containing communication type cables. Remove applicable Communication Grommet and replace with Cat. No. FFD-P.

Step 5. Installation complete.

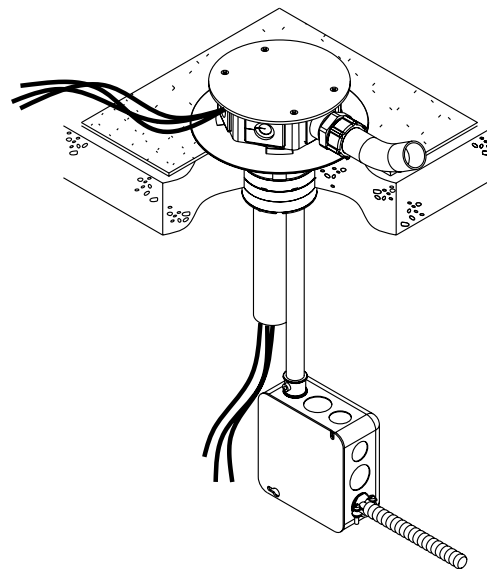

The RC9 Pedestal/Furniture Feed Series Poke-Thru Devices are UL Listed and Classified to U.S. and Canadian safety standards to the following conditions:

The RC9FFS Poke-Thru Stem with the 291-H/BTC Single Service Head, the 292-H/BTC Double Service Head, or the RC9CFFTC Double Service Head; the RC91GHBTC, RC92GHBTC, or the RC9AFFTC factory assembled poke-thru devices; the RC79APTC Abandonment Fittings are for use with 1-, 1 1/2-, or 2-hour rated unprotected, reinforced concrete floors and 1-, 1 1/2-, or 2-hour rated floors employing unprotected steel floor units and concrete topping (D900 Series Designs), or concrete floors with suspended ceilings. (Fire resistive designs with suspended ceilings should have provisions for accessibility in the ceiling area below the poke-thru fittings).

The assembled poke-thru stem and the single or double service heads or the abandonment fittings will not reduce the ratings of the floor assembly when the thickness and type of concrete (required for the specific rating) are within the specified limits and the fittings are installed as specified:

1. **Spacing** – Minimum of 2' [610mm] OC and not more than one unit per 65 sq. ft. [6 sq. m] of floor area in each span.
2. **Concrete** – Minimum thickness of structural concrete topping of 2 1/4" [57mm] over metal deck or a minimum 3" [76mm] thick reinforced concrete slab. Unit weight of concrete to be 110 to 155 pcf.
3. **Installation** – Mounted in a 3" diameter core-drilled hole in concrete per installation instructions accompanying the fittings or abandonment fittings. For use with power circuits, data and/or maximum 50-pair size telephone cables as tabulated below:

POKE-THRU FITTING TYPE	SERVICE FITTING TYPE (C)	POWER CONDUCTORS (A)	COMMUNICATION CONDUCTORS (B)
RC9FFS	RC9CFFTC	(A1) 8 + 2 (.05726 sq. in.) [36.944mm ²]	128 (.06400 sq. in.) [41.293mm ²]
	291-H/BTC (pwr/communication)	3 (.01536 sq. in.) [9.9103mm ²]	100 (.05000 sq. in.) [32.260mm ²]
	291-H/BTC (pwr/communication)	(D) 7 (.03584 sq. in.) [23.124mm ²]	60 (.03000 sq. in.) [19.356mm ²]
	291-H/BTC (pwr only)	(D) 13 (.06656 sq. in.) [42.946mm ²]	-
	291-H/BTC (communication only)	-	130 (.06500 sq. in.) [41.938mm ²]
	292-H/BTC (pwr/communication)	10 (.05120 sq. in.) [33.034mm ²]	100 (.05000 sq. in.) [32.260mm ²]
	292-H/BTC (pwr only)	12 (.06144 sq. in.) [39.641mm ²]	-
	292-H/BTC (communication only)	-	130 (.06500 sq. in.) [41.938mm ²]
RC9AFFTC	-	(A1) 8 + 2 (.05726 sq. in.) [36.944 mm ²]	128 (.06400 sq. in.) [41.293mm ²]
RC91GHBTC (pwr/communication)	-	3 (.01536 sq. in.) [9.9103mm ²]	100 (.05000 sq. in.) [32.260mm ²]
RC91GHBTC (pwr/communication)	-	(D) 7 (.03584 sq. in.) [23.124mm ²]	60 (.03000 sq. in.) [19.356mm ²]
RC91GHBTC (pwr only)	-	(D) 13 (.06656 sq. in.) [42.946mm ²]	-
RC91GHBTC (communication only)	-	-	130 (.06500 sq. in.) [41.938mm ²]
RC92GHBTC (pwr/communication)	-	10 (.05120 sq. in.) [33.034mm ²]	100 (.05000 sq. in.) [32.260mm ²]
RC92GHBTC (pwr only)	-	12 (.06144 sq. in.) [39.641mm ²]	-
RC92GHBTC (communication only)	-	-	130 (.06500 sq. in.) [41.938mm ²]

The "TC" suffix letters indicate that device may be installed on tile or carpet covered concrete floors. The "LJB" suffix letters indicate units supplied without a junction box.

- (A) Maximum number of No. 12 AWG Type THHN conductors in power compartment of poke-thru fitting.
- (A1) Maximum number of No. 12 AWG Type THHN conductors plus maximum number of No. 10 AWG THHN conductors in power compartment of poke-thru fitting.
- (B) Maximum number of 22 AWG conductors in low voltage compartment of poke-thru fitting (4-pair cables have (8) conductors, 25-pair cable have (50) conductors). When conductors larger than No. 22 AWG are used, the aggregate cross-sectional area of the copper conductors shall not exceed the aggregate cross-sectional area of the 22 AWG conductors permitted in the low voltage compartment.
- (C) 1/2", 3/4", and 1" flexible metallic conduit and fittings may be used with the 291-H/BTC or 292-H/BTC Service Head Fittings or the factory assembled RC91GHBTC or RC92GHBTC Poke-Thru Devices.
- (D) Maximum number of power conductors when flexible metallic conduit is used. Maximum number of communication conductors to be adjusted accordingly.

NOTE: For use on carpet covered and tile floors up to 3/4" [19.1mm] thick.

Copper Cross Sectional Area of Commonly Used Conductors	
Size	Solid
#24	.00032 sq. in. [.20645mm ²]
#22	.00050 sq. in. [.32258mm ²]
#14	.00323 sq. in. [2.08386mm ²]
#12	.00512 sq. in. [3.30321mm ²]
#10	.00815 sq. in. [5.25805mm ²]
# 8	.01296 sq. in. [8.36127mm ²]

NOTE: Use above values for solid or stranded conductors.

Carpet Cutout Template

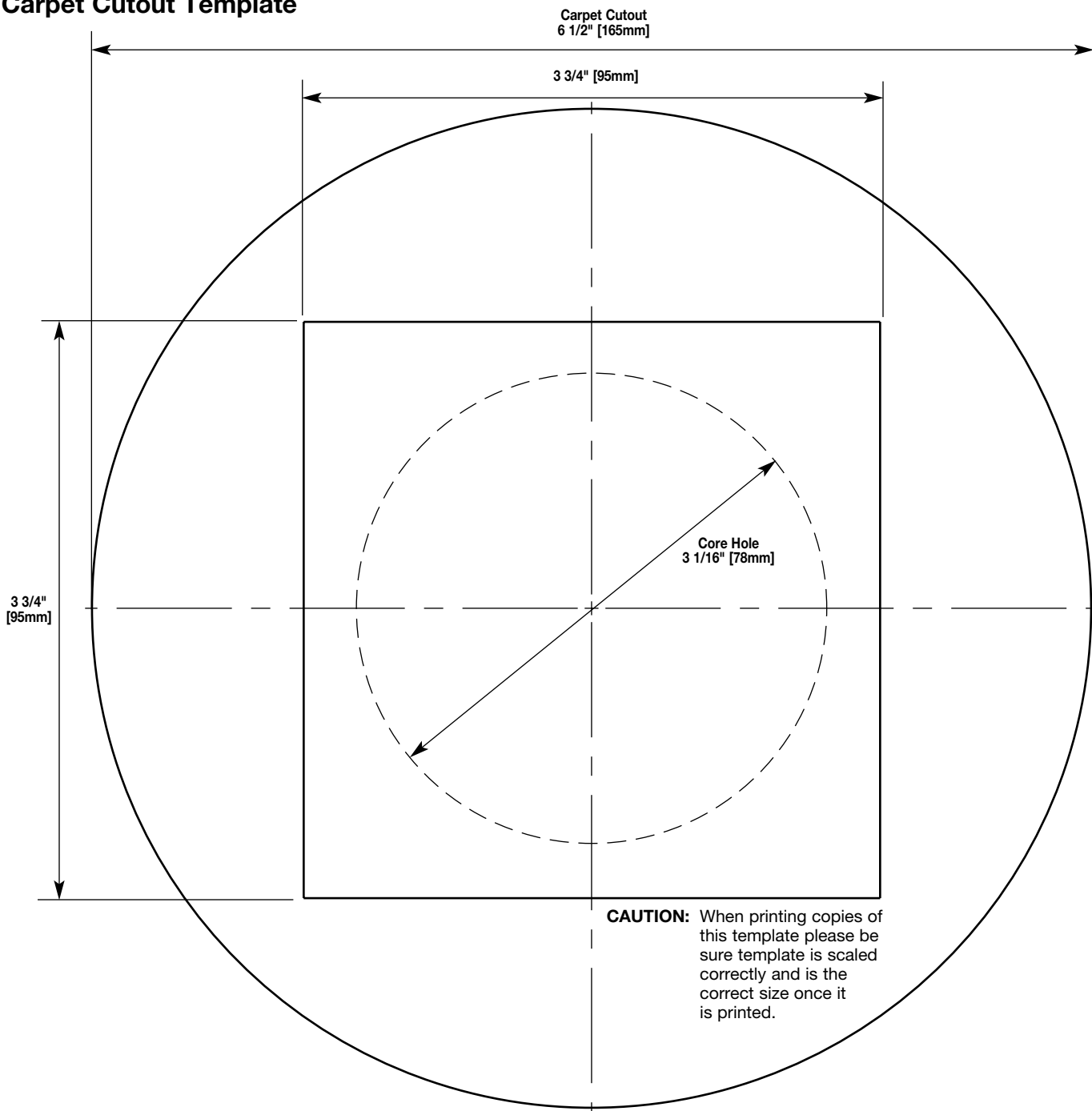

CAUTION: When printing copies of this template please be sure template is scaled correctly and is the correct size once it is printed.

WIREMOLD



Wiremold / Legrand

U.S. and International:

60 Woodlawn Street • West Hartford, CT 06110

1-800-621-0049 • FAX 860-232-2062 • Outside U.S. 860-233-6251

Canada:

570 Applewood Crescent • Vaughan, Ontario L4K 4B4

1-800-723-5175 • FAX 905-738-9721

