

WIREMOLD



FlameStopper™ Thru-Wall & Thru-Floor Fittings INSTALLATION INSTRUCTIONS

Installation Instruction No.: INS0010R2 – Updated January 2007

Wiremold / Legrand Electrical Systems conform to and should be installed and properly grounded in compliance with requirements of the current National Electrical Code, Canadian Electrical Code or codes administered by local authorities.

All electrical products may represent possible shock or fire hazard if improperly installed or used. Wiremold / Legrand electrical products are UL Listed to U.S. and Canadian safety standards, made for interior use only, and should be installed in conformance with current local building codes and/or the National Electrical Code.

Products Covered: FS2R, FS4R, FS2RHS, FS4RHS, FS2RWP8, FS4RWP12

FS2R, FS4R INSTALLATION – Thru-Wall & Thru-Floor:

1. Determine location and drill pilot hole thru wall or floor.

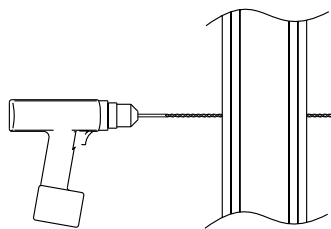

NOTE: Use core drill when going through concrete or block walls or floors.

Drill hole using 4 3/4" [120mm] for FS4R and 2 1/4" [58mm] for FS2R.

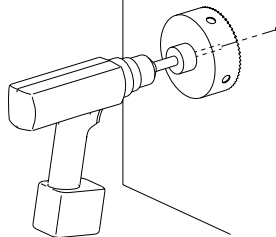

2. Measure wall or floor thickness.

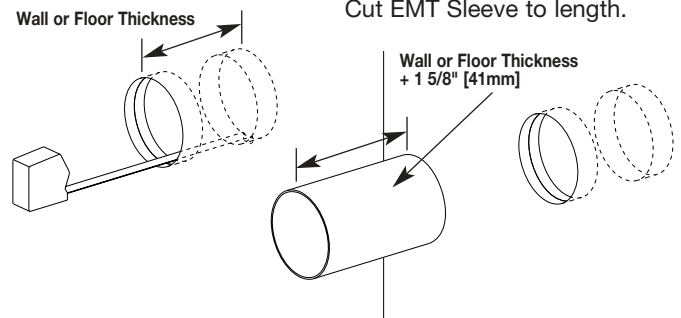

- 3.

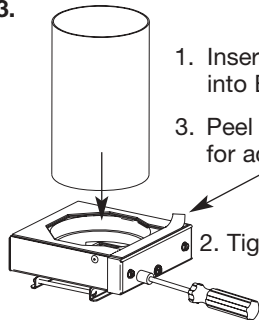

1. Insert EMT into Box.
2. Tighten Clamp.
3. Peel off backing for adhesive.

NOTE: Do not force EMT through intumescent material.

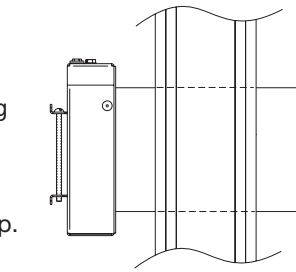

4. Stick on Wall or floor (Make sure wall or floor is clean and dust-free).

- 4.

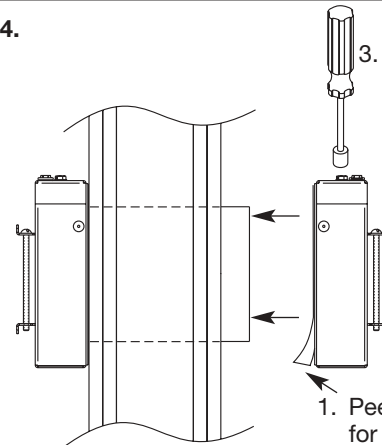

3. Tighten Clamp.

2. Stick on Wall or floor.

1. Peel off backing for adhesive.

5. Install cabling then adjust sliding doors to be snug around cables by turning side screws.

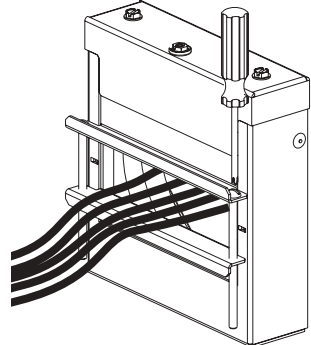

NOTE: Do not over tighten.

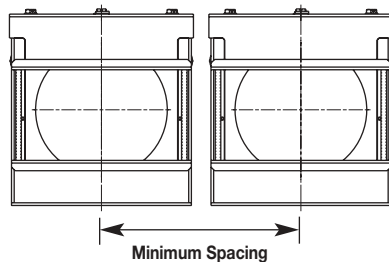

CAT NO.	MINIMUM SPACING
FS4R	6 1/8" [155MM]
FS2R	3 7/8" [98MM]

6. Ground in accordance with National Electrical Codes.

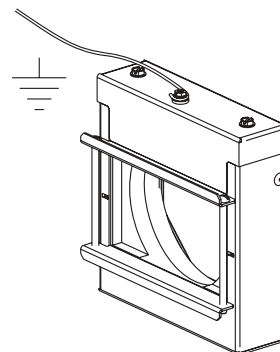

7. Fill out and place label on wall or floor near FlameStopper.

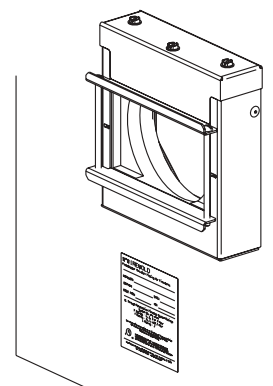

Through-penetration Firestop Systems System No. W-L-3300

December 28, 2005

Ratings – 1, 2, 3 and 4 Hr (See Item 1)

T Ratings – 0, 1/4, 1/2, 3/4, 1, 2, 3, and 4 Hr (See Item 3)

L Rating at Ambient – 2.6 CFM and 2.8 CFM (See Item 3)

L Rating at 400°F – 1.9 CFM and 1.3 CFM (See Item 3)

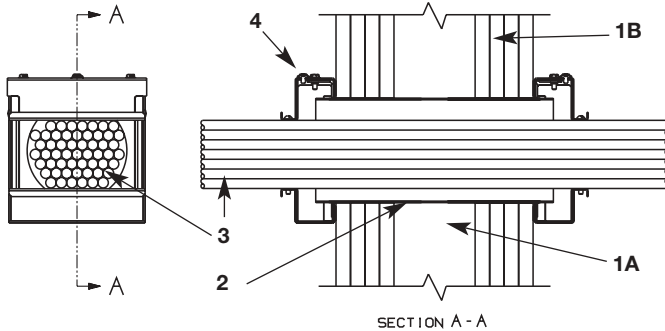

1. Wall Assembly – The 1, 2, 3 or 4 hr fire-rated gypsum board/stud wall assembly shall be constructed of the materials and in the manner described within the individual U300, U400 or V400 Series Wall or Partition Designs in the UL Fire Resistance Directory and shall incorporate the following construction features:

A. Studs – Wall framing shall consist of either wood studs or steel channel studs. Wood studs to consist of nom 2 by 4 in. [51 by 102 mm] lumber spaced max 16 in. [406 mm] OC. Steel studs to be min 1-5/8 in. [41 mm] wide and spaced max 24 in. [610 mm] OC.

B. Gypsum Board* – Thickness, type, number of layers and fasteners as specified in the individual Wall and Partition Design. Diam of opening shall be 2-1/4 in. [57 mm] and 4-3/4 in. [121 mm] for the nom 2 in. [51 mm] and 4 in. [102 mm] sleeves (Item 2), respectively.

The hourly F Rating of the firestop system is dependent upon the hourly rating of the wall in which it is installed.

2. Metallic Sleeve – Nom 2 in. [51 mm] or 4 in. [102 mm] diam electrical metallic tubing (EMT), dependent on the size of the firestop device (Item 4). The sleeve is to extend a nom 3/4 in. beyond both surfaces of wall. The annular space between the sleeve and the periphery of opening shall be min 0 in. (continuous point contact) to max 1/4 in. [6 mm].

3. Cables – Aggregate cross-sectional area of cables in the EMT sleeve to be 0% to max 60% of the aggregate cross-sectional area of the EMT sleeve. When there is no cable fill, device cover is to be tightly closed. Cables to be rigidly supported on both sides of the wall assembly. Any combination of the following types of cables may be used:

- A. Single conductor No. 18 AWG (or smaller) RG/U coaxial cable with fluorinated ethylene insulation and jacketing.
- B. Fiber optic cable with polyvinyl chloride (PVC) or polyethylene (PE) jacket and insulation having a max diameter of 5/8 in. [16 mm].
- C. Max 4 pair No. 22 AWG (or smaller) copper conductor data cable with polyvinyl chloride (PVC) or plenum rated jacketing and insulation.
- D. Max 4/C No. 2 AWG (or smaller) copper conductor cable with XLPE/PVX insulation and PVC jacket.
- E. Max 100 pair No. 24 AWG (or smaller) copper conductor telecommunication cable with polyvinyl chloride (PVC) jacketing and insulation.
- F. Max 400 pair No. 24 AWG (or smaller) copper conductor telecommunication cable with polyvinyl chloride (PVC) jacketing and insulation.
- G. Max 8/C 12 AWG (or smaller) copper conductor steel Metal-Clad or Armored-Clad cable.

The hourly T Rating of the firestop system is equal to the F Rating when no cable fill is used or when cables A or B are used. The hourly T Rating is equal to the F Rating up to 3 hr when cable C is used. The hourly T Rating is 1 hr when cable D is installed in 2, 3 or 4 hr rated walls, 1/2 hr in 1 hr rated walls. The hourly T Rating is 1 hr when cable E is installed in 4 hr rated walls and 0 hr in 1, 2 or 3 hr rated walls. The hourly T Rating is 3/4 hr when cable F is installed in 2, 3 or 4 hr rated walls, 0 hr in 1 hr rated walls. The hourly T Rating is 1/4 hr when cable G is installed in 2, 3 or 4 hr rated walls, 0 hr in 1 hr rated walls.

The L Rating at ambient and 400°F with no cable fill is 2.6 CFM and 1.9 CFM, respectively. The L Rating at ambient and 400°F with cable fill is 2.8 CFM and 1.3 CFM, respectively.

4. Firestop Device – Device to be installed in accordance with the accompanying installation instructions. Device to be installed and secured to the EMT sleeve both sides of wall.

THE WIREMOLD COMPANY – FS2R FlameStopper, FS4R FlameStopper

*Bearing the UL Classification Mark

Through-penetration Firestop Systems System No. C-AJ-3271

January 12, 2006

F Rating – 3 Hr*

T Ratings – 1/4, 3/4, 1, & 3 (See Item 3)

L Rating at Ambient – 2.6 CFM and 2.8 CFM (See Item 3)

L Rating at 400°F – 1.9 CFM and 1.3 CFM (See Item 3)

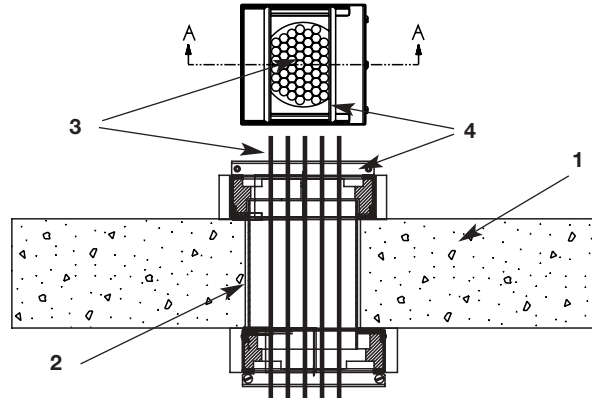

1. Floor & Wall Assembly – Min 4-1/2 in. [114 mm] thick reinforced lightweight or normal weight (100-150 pcf or 1600-2400 kg/m3) concrete floor or wall. Wall may also be constructed of any UL Classified Concrete Blocks*. Maximum diameter of opening is 4-1/2 in. [114 mm].

See **Concrete Blocks** (CAZT) category in the Fire Resistance Directory for names of manufacturers.

***4-Hour Rated Assemblies (System No. W-J-3154):** for concrete wall installation, minimum 6 in. [152mm] thick, reinforced lightweight or normal weight (100-150 pcf or 1600-2400 kg/m3) concrete wall.

2. Metallic Sleeve – Nom 2 in. [51 mm] or 4 in. [102 mm] diameter electrical metallic tubing (EMT), dependent on the size of the firestop device (Item 4). The sleeve is to extend a nom 5/8 in. [16mm] beyond both surfaces of floor or wall. The annular space between the sleeve and the periphery of opening shall be min 0 in. (continuous point contact) to max 1/4 in. [6 mm].

3. Cables – Aggregate cross-sectional area of cables in the EMT sleeve to be 0% to max 60% of the aggregate cross-sectional area of the EMT sleeve. When there is no cable fill, device cover is to be tightly closed. Cables to be rigidly supported on both sides of the wall assembly. Any combination of the following types of cables may be used:

- A. Single conductor No. 18 AWG (or smaller) RG/U coaxial cable with fluorinated ethylene insulation and jacketing.
- B. Fiber optic cable with polyvinyl chloride (PVC) or polyethylene (PE) jacket and insulation having a max diameter of 5/8 in. [16 mm].
- C. Max 4 pair No. 22 AWG (or smaller) copper conductor data cable with polyvinyl chloride (PVC) or plenum rated jacketing and insulation.
- D. Max 4/C No. 2 AWG (or smaller) copper conductor cable with XLPE/PVX insulation and PVC jacket.
- E. Max 100 pair No. 24 AWG (or smaller) copper conductor telecommunication cable with polyvinyl chloride (PVC) jacketing and insulation.
- F. Max 400 pair No. 24 AWG (or smaller) copper conductor telecommunication cable with polyvinyl chloride (PVC) jacketing and insulation.
- G. Max 8/C 12 AWG (or smaller) copper conductor steel Metal-Clad or Armored-Clad cable.

The hourly T Rating is 3 hr when no cable fill is used or when cables A, B or C are used. The hourly T Rating is 3/4 hr when cable D is used. The hourly T Rating is 1 hr when cables E and F are used. The hourly T Rating is 1/4 hr when cable G is used.

4. Firestop Device – Device to be installed in accordance with the accompanying installation instructions. Device to be installed and secured to the EMT sleeve both sides of wall or floor.

THE WIREMOLD COMPANY – FS2R FlameStopper, FS4R FlameStopper

*Bearing the UL Classification Mark



FIRESTOP DEVICE FOR USE IN THROUGH-PENETRATION
FIRESTOP SYSTEMS. SEE UL DIRECTORY OF PRODUCTS
CERTIFIED FOR CANADA AND UL FIRE RESISTANCE DIRECTORY

FS2RHS, FS4RHS HEAT SHIELD INSTALLATION:

NOTE: Heat Shield is only required if conduit extends out from the wall more than 7/8" [22mm].

Add-On Kit used to retrofit Flamestopper Thru-Wall Fitting onto existing 2" trade size or 4" trade size EMT pipe. Use FS2RHS – 2" trade size EMT with FS2R. Use FS4RHS – 4" trade size EMT with FS4R.

1. Remove any existing firestop material from within end of EMT Pipe.

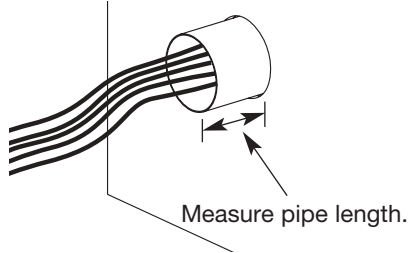

NOTE: Pipe cannot exceed 6" [152mm].

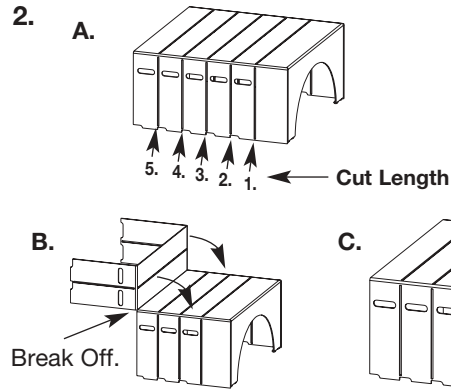

PIPE LENGTH	HEAT SHIELD CUT LENGTH
1/2" – 7/8"	No Shield Needed
7/8" – 1"	1
1" – 2"	2
2" – 3"	3
3" – 4"	4
4" – 5"	5
5" – 6"	No EMT

3. Remove Top and Front Door and drop Cables into Fitting.

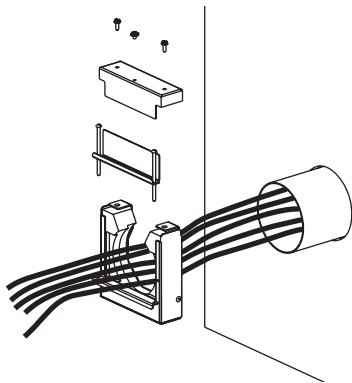

4. A. Install Heat Shield around Product.

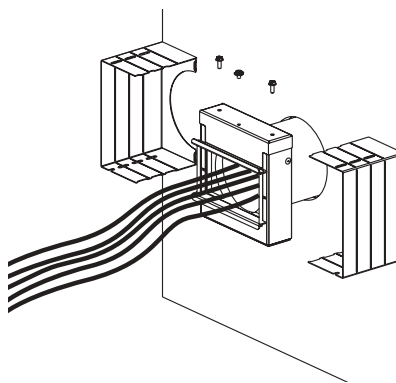

- B. Tighten Clamp.

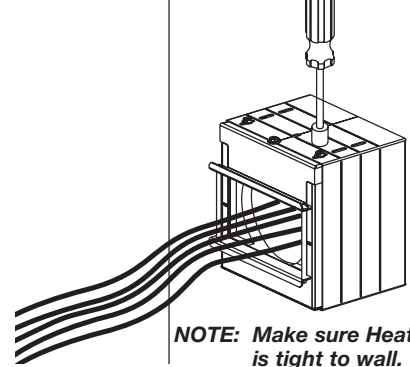

NOTE: Make sure Heat Shield is tight to wall.

5. Move Sliding Doors to be snug around Cables by turning Side Screws.

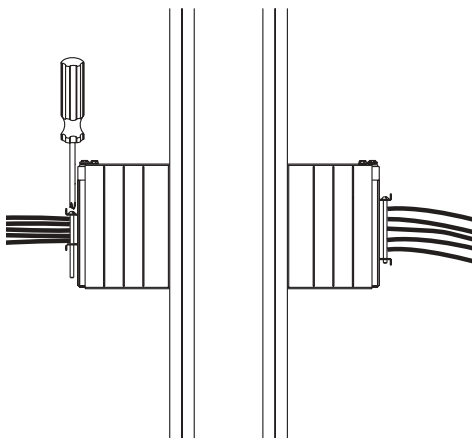

6. A. Ground in accordance with National Electrical Codes.

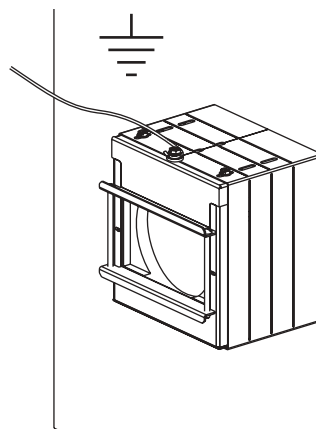

- B. Fill out and place label on wall near FlameStopper.

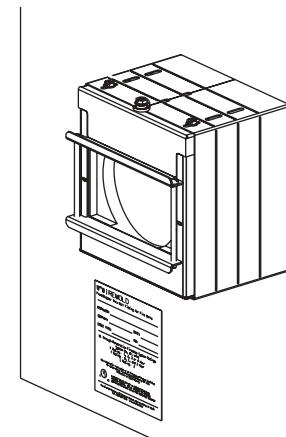

Through-penetration Firestop Systems System No. W-L-3301

December 28, 2005

F Ratings – 1, 2, 3 and 4 Hr (See Item 1)

T Ratings – 0, 1/4, 1/2, 3/4, 1, 2, 3 and 4 Hr (See Item 3)

L Rating at Ambient – 3.7 CFM and 4.6 CFM (See Item 3)

L Rating at 400°F – 2.1 CFM and 2.0 CFM (See Item 3)

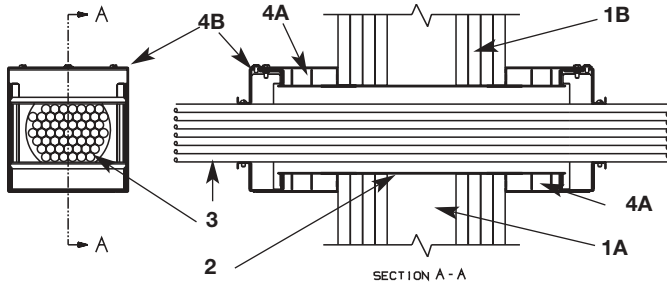

Through-penetration Firestop Systems System No. W-J-3155

December 28, 2005

F Ratings – 1, 2, 3 and 4 Hr (See Item 1)

T Ratings – 0, 1/4, 1/2, 3/4, 1, 2, 3 and 4 Hr (See Item 3)

L Rating at Ambient – 3.7 CFM and 4.6 CFM (See Item 3)

L Rating at 400°F – 2.1 CFM and 2.0 CFM (See Item 3)

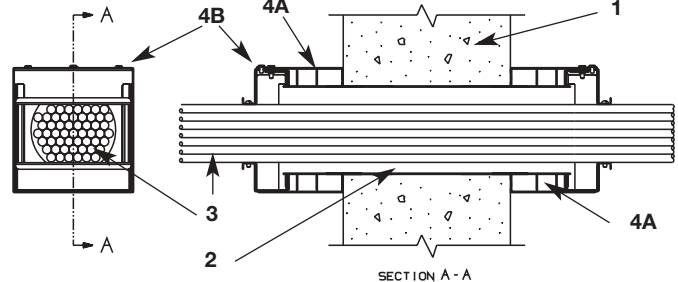

1. Wall Assembly – The 1, 2, 3 or 4 hr fire-rated gypsum board/stud wall assembly shall be constructed of the materials and in the manner described within the individual U300, U400 or V400 Series Wall or Partition Designs in the UL Fire Resistance Directory and shall incorporate the following construction features:

A. Studs – Wall framing shall consist of either wood studs or steel channel studs. Wood studs to consist of nom 2 by 4 in. [51 by 102 mm] lumber spaced max 16 in. [406 mm] OC. Steel studs to be min 1-5/8 in. [41 mm] wide and spaced max 24 in. [610 mm] OC.

B. Gypsum Board* – Thickness, type, number of layers and fasteners as specified in the individual Wall and Partition Design. Diam of opening shall be 2-1/4 in. [57 mm] and 4-3/4 in. [121 mm] for the nom 2 in. [51 mm] and 4 in. [102 mm] sleeves (Item 2), respectively.

The hourly F Rating of the firestop system is dependent upon the hourly rating of the wall in which it is installed.

2. Metallic Sleeve – Nom 2 in. [51 mm] or 4 in. [102 mm] diam electrical metallic tubing (EMT), dependent on the size of the firestop device (Item 4). The sleeve is to extend a min 7/8 in. to a max 6 in. [152 mm] beyond both surfaces of wall. The annular space between the sleeve and the periphery of opening shall be min 0 in. (continuous point contact) to max 1/4 in. [6 mm].

3. Cables – Aggregate cross-sectional area of cables in the EMT sleeve to be 0% to max 60% of the aggregate cross-sectional area of the EMT sleeve. When there is no cable fill, device cover is to be tightly closed. Cables to be rigidly supported on both sides of the wall assembly. Any combination of the following types of cables may be used:

A. Single conductor No. 18 AWG (or smaller) RG/U coaxial cable with fluorinated ethylene insulation and jacketing.

B. Fiber optic cable with polyvinyl chloride (PVC) or polyethylene (PE) jacket and insulation having a max diameter of 5/8 in. [16 mm].

C. Max 4 pair No. 22 AWG (or smaller) copper conductor data cable with polyvinyl chloride (PVC) or plenum rated jacketing and insulation.

D. Max 4/C No. 2 AWG (or smaller) copper conductor cable with XLPE/PVX insulation and PVC jacket.

E. Max 100 pair No. 24 AWG (or smaller) copper conductor telecommunication cable with polyvinyl chloride (PVC) jacketing and insulation.

F. Max 400 pair No. 24 AWG (or smaller) copper conductor telecommunication cable with polyvinyl chloride (PVC) jacketing and insulation.

G. Max 8/C 12 AWG (or smaller) copper conductor steel Metal-Clad or Armored-Clad cable.

The hourly T Rating of the firestop system is equal to the F Rating when no cable fill is used or when cables A or B are used. The hourly T Rating is equal to the F Rating up to 3 hr when cable C is used. The hourly T Rating is 1 hr when cable D is installed in 2, 3 or 4 hr rated walls, 1/2 hr in 1 hr rated walls. The hourly T Rating is 1 hr when cable E is installed in 4 hr rated walls and 0 hr in 1, 2 or 3 hr rated walls. The hourly T Rating is 3/4 hr when cable F is installed in 2, 3 or 4 hr rated walls, 0 hr in 1 hr rated walls. The hourly T Rating is 1/4 hr when cable G is installed in 2, 3 or 4 hr rated walls, 0 hr in 1 hr rated walls.

The L Rating at ambient and 400°F with no cable fill is 3.7 CFM and 2.1 CFM, respectively. The L Rating at ambient and 400°F with cable fill is 4.6 CFM and 2.0 CFM, respectively.

4. Firestop System – The firestop system shall consist of the following:

A. Firestop Device* – Heat Shield – The heat shield shall be installed in accordance with the accompanying installation instructions. Device to be installed around the outside of the EMT sleeve both sides of wall. – THE WIREMOLD CO. – FS2RHS, FS4RHS

B. Firestop Device* – Device to be installed in accordance with the accompanying installation instructions. Device to be installed and secured to the heat shield (Item 4A) at the end of the EMT sleeve on both sides of wall. – THE WIREMOLD CO. – FS2R FlameStopper, FS4R FlameStopper

*Bearing the UL Classification Mark

1. Wall Assembly – Min 4-1/2 in. [114 mm] thick reinforced lightweight or normal weight (100-150 pcf or 1600-2400 kg/m³) concrete for 1 and 2 hr rated assemblies. Min 6 in. [152 mm] thick reinforced lightweight or normal weight (100-150 pcf or 1600-2400 kg/m³) concrete for 3 and 4 hr rated assemblies. Wall may also be constructed of any UL Classified Concrete Blocks. Diam of opening shall be 2-1/4 in. [57 mm] or 4-3/4 in. [121 mm] for the nom 2 in. [51 mm] and 4 in. [102 mm] sleeves (Item 2).

See Concrete Blocks (CAZT) category in the Fire Resistance Directory for names of manufacturers.

The hourly F Rating of the firestop system is dependent upon the hourly rating of the wall in which it is installed.

2. Metallic Sleeve – Nom 2 in. [51 mm] or 4 in. [102 mm] diam electrical metallic tubing (EMT), dependent on the size of the firestop device (Item 4). The sleeve is to extend a min 7/8 in. [22.2mm] to a max 6 in. [152mm] beyond both surfaces of wall. The annular space between the sleeve and the periphery of opening shall be min 0 in. (continuous point contact) to max 1/4 in. [6 mm].

3. Cables – Aggregate cross-sectional area of cables in the EMT sleeve to be 0% to max 60% of the aggregate cross-sectional area of the EMT sleeve. When there is no cable fill, device cover is to be tightly closed. Cables to be rigidly supported on both sides of the wall assembly. Any combination of the following types of cables may be used:

A. Single conductor No. 18 AWG (or smaller) RG/U coaxial cable with fluorinated ethylene insulation and jacketing.

B. Fiber optic cable with polyvinyl chloride (PVC) or polyethylene (PE) jacket and insulation having a max diameter of 5/8 in. [16 mm].

C. Max 4 pair No. 22 AWG (or smaller) copper conductor data cable with polyvinyl chloride (PVC) or plenum rated jacketing and insulation.

D. Max 4/C No. 2 AWG (or smaller) copper conductor cable with XLPE/PVX insulation and PVC jacket.

E. Max 100 pair No. 24 AWG (or smaller) copper conductor telecommunication cable with polyvinyl chloride (PVC) jacketing and insulation.

F. Max 400 pair No. 24 AWG (or smaller) copper conductor telecommunication cable with polyvinyl chloride (PVC) jacketing and insulation.

G. Max 8/C 12 AWG (or smaller) copper conductor steel Metal-Clad or Armored-Clad cable.

The hourly T Rating of the firestop system is equal to the F Rating when no cable fill is used or when cables A or B are used. The hourly T Rating is equal to the F Rating up to 3 hr when cable C is used. The hourly T Rating is 1 hr when cable D is installed in 2, 3 or 4 hr rated walls, 1/2 hr in 1 hr rated walls. The hourly T Rating is 1 hr when cable E is installed in 4 hr rated walls and 0 hr in 1, 2 or 3 hr rated walls. The hourly T Rating is 3/4 hr when cable F is installed in 2, 3 or 4 hr rated walls, 0 hr in 1 hr rated walls. The hourly T Rating is 1/4 hr when cable G is installed in 2, 3 or 4 hr rated walls, 0 hr in 1 hr rated walls.

The L Rating at ambient and 400°F with no cable fill is 3.7 CFM and 2.1 CFM, respectively. The L Rating at ambient and 400°F with cable fill is 4.6 CFM and 2.0 CFM, respectively.

4. Firestop System – The firestop system shall consist of the following:

A. Firestop Device* – Heat Shield – The heat shield shall be installed in accordance with the accompanying installation instructions. Device to be installed around the outside of the EMT sleeve both sides of wall. – THE WIREMOLD CO. – FS2RHS, FS4RHS

B. Firestop Device* – Device to be installed in accordance with the accompanying installation instructions. Device to be installed and secured to the heat shield (Item 4A) at the end of the EMT sleeve on both sides of wall. – THE WIREMOLD CO. – FS2R FlameStopper, FS4R FlameStopper

*Bearing the UL Classification Mark

FS2RWP8, FS4RWP12 WALL PLATE INSTALLATION:

Add-On Kit used to retrofit Flamestopper Thru-Wall Fitting over holes in the wall cables already installed. Use FS2RWP8 – 8" trade size Wall Covering Plate with FS2R. Use FS2RWP12 – 12" trade size Wall Covering Plate with FS4R.

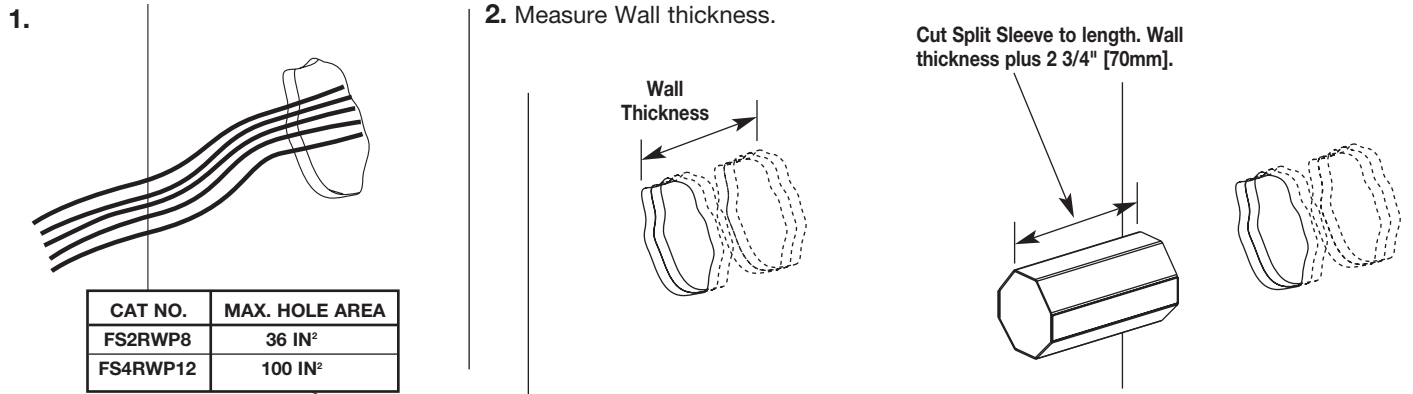

3. Use Insulation as template for holes.

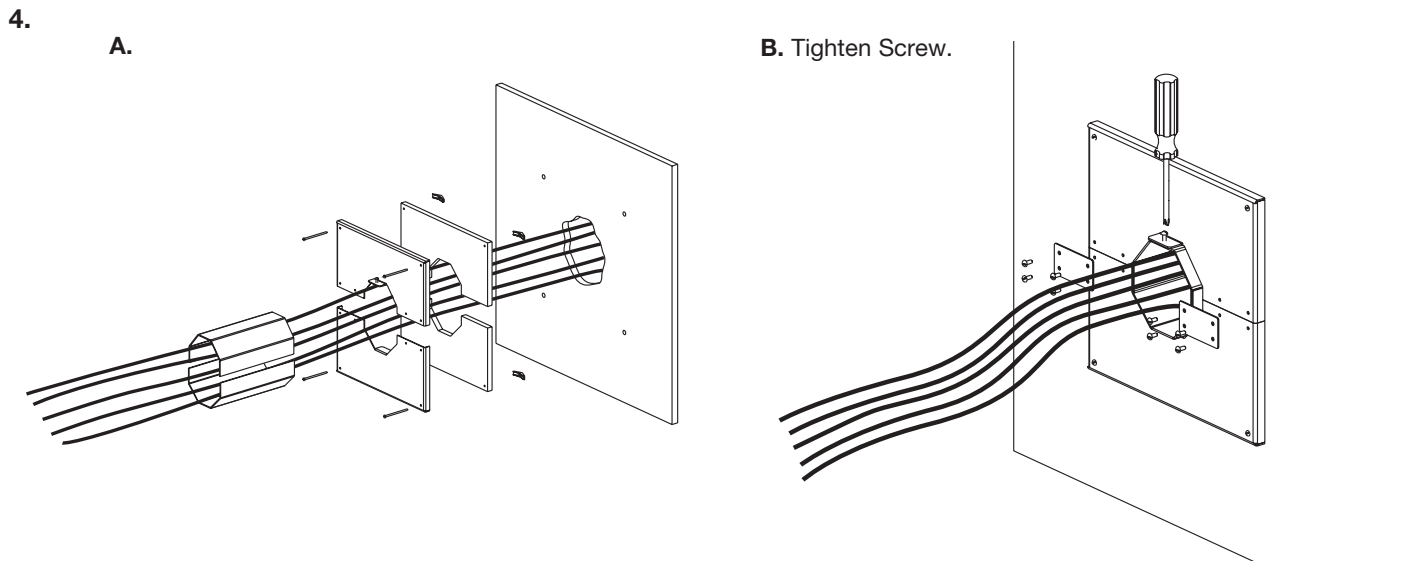
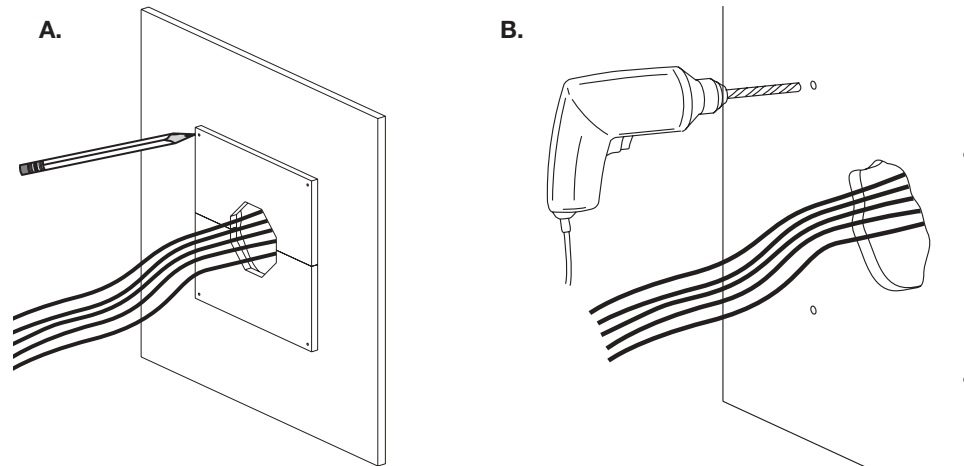

FS2RWP8, FS4RWP12 WALL PLATE INSTALLATION (continued):

5.

A.

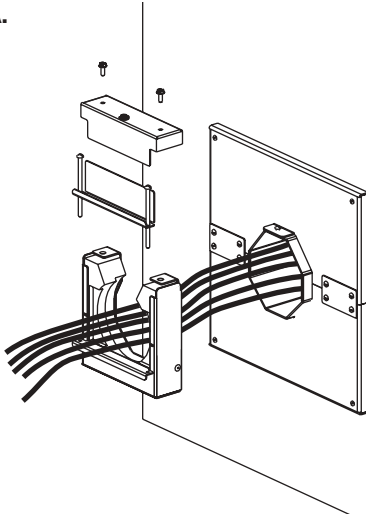

B. Tighten Clamp.

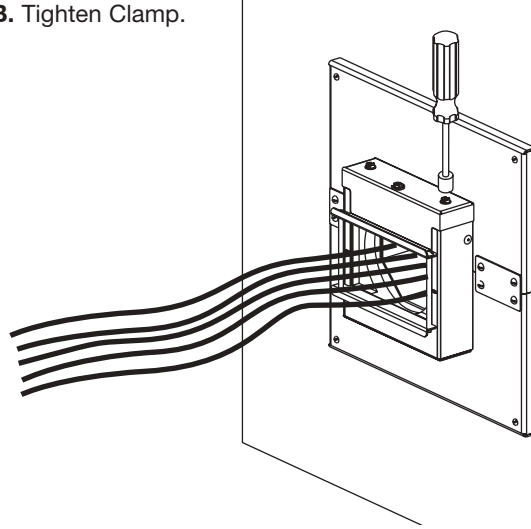

6. Adjust Sliding Doors to be snug around Cable by turning Side Screws.

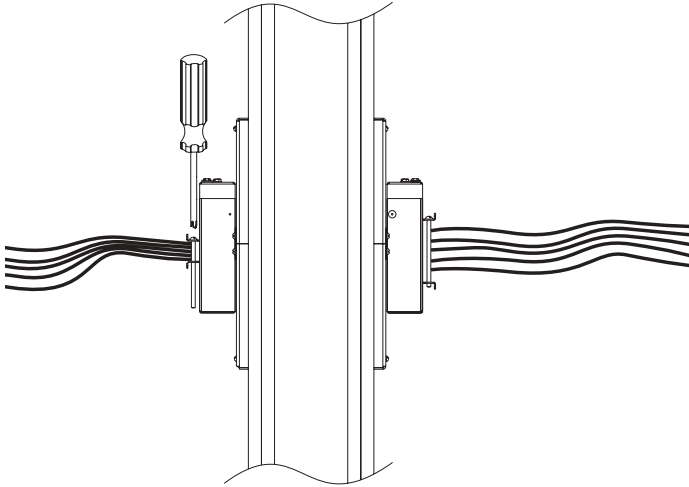

7.

A. Ground in accordance with National Electrical Codes.

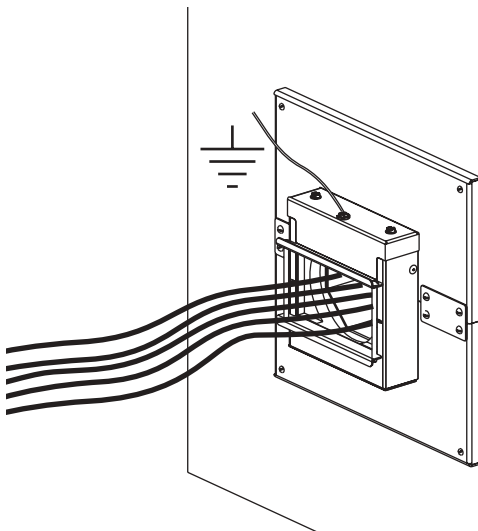

B. Fill out and place label on wall near FlameStopper.

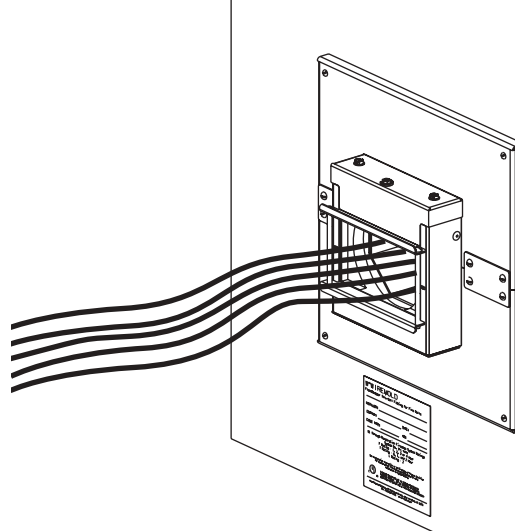

Through-penetration Firestop Systems System No. W-L-3302

December 28, 2005

F Ratings – 1, and 2 Hr (See Item 1)

T Ratings – 0, 1/4, 1/2, 1 and 1-1/4 Hr (See Item 3)

L Rating at Ambient – 1.7 CFM and 3.3 CFM (See Item 3)

L Rating at 400°F – 1.8 CFM and 2.0 CFM (See Item 3)

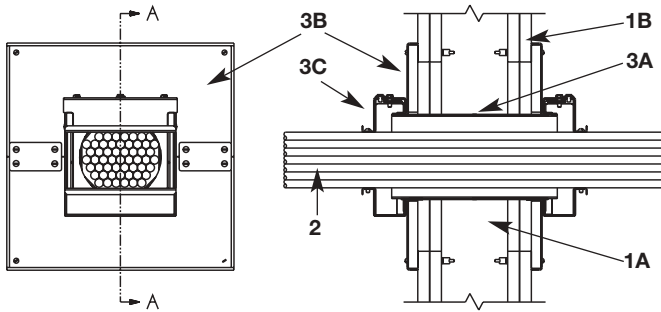

1. Wall Assembly – The 1 or 2 hr fire-rated gypsum board/stud wall assembly shall be constructed of the materials and in the manner described within the individual U300, U400 or V400 Series Wall or Partition Designs in the UL Fire Resistance Directory and shall incorporate the following construction features:

- A. Studs** – Wall framing shall consist of either wood studs or steel channel studs. Wood studs to consist of nom 2 by 4 in. [51 by 102 mm] lumber spaced max 16 in. [406 mm] OC. Steel studs to be min 2-1/2 in. [64 mm] wide and spaced max 24 in. [610 mm] OC.
- B. Gypsum Board*** – Thickness, type, number of layers and fasteners as specified in the individual Wall and Partition Design. Max area of opening shall be 100 sq in. [645 sq cm] with a max dimension of 10 in. [254 mm] for the FS4RWP12 device (Item 3B). Max area of opening shall be 36 sq in. [232 sq cm] with a max dimension of 6 in. [152 mm] for the FS4RWP12 device (Item 3B).

The hourly F Rating of the firestop system is dependent upon the hourly rating of the wall in which it is installed.

2. Cables – Aggregate cross-sectional area of cables in the EMT sleeve to be 0% to max 60% of the aggregate cross-sectional area of the EMT sleeve. When there is no cable fill, device cover is to be tightly closed. Cables to be rigidly supported on both sides of the wall assembly. Any combination of the following types of cables may be used:

- A.** Max 4 pair No. 22 AWG (or smaller) copper conductor data cable with polyvinyl chloride (PVC) or plenum rated jacketing and insulation.
- B.** Single conductor No. 18 AWG (or smaller) RG/U coaxial cable with fluorinated ethylene insulation and jacketing.
- C.** Fiber optic cable with polyvinyl chloride (PVC) or polyethylene (PE) jacket and insulation having a max diameter of 5/8 in. (16 mm).
- D.** Max 8/C 12 AWG (or smaller) copper conductor steel Metal-Clad or Armored-Clad cable.

The hourly T Rating of the firestop system is 1-1/4 hr when no cable fill is used or when cables A or C are used in 2 hr rated walls, 1/2 hr in 1 hr rated walls. The hourly T Rating is 1 hr when cable B is installed in 2 hr rated walls, 1/2 hr in 1 hr rated walls. The hourly T Rating is 1/4 hr when cable D is installed in 2 hr rated walls, 0 hr in 1 hr rated walls.

The L Rating at ambient and 400°F with no cable fill is 1.7 CFM and 1.8 CFM, respectively.

The L Rating at ambient and 400°F with cable fill is 3.3 CFM and 2.0 CFM, respectively.

3. Firestop System – The firestop system shall consist of the following:

- A. Sleeve** – The octagonal, two-piece, 16 gauge (or heavier) galv steel sleeve shall be installed in accordance with the accompanying installation instructions.
- B. Firestop Device*** – Wall Covering Plate – The two-piece wall covering plates shall be installed on both sides of wall in accordance with the accompanying installation instructions. The plates shall overlap opening a min 1 in. [25 mm] on all sides. The plates are secured around sleeve and attached to gypsum board with min 1/8 in. [3.2 mm] diam steel toggle bolts. A min 16 gauge, 2-3/4 by 1-1/2 in. [70 by 38 mm] galv steel plate is secured to the steel plates over the seams between top and bottom plates with min No. 14 steel sheet metal screws.

THE WIREMOLD CO. – FS2RWP8, FS4RWP12

- C. Firestop Device*** – Device to be installed in accordance with the accompanying installation instructions. Device to be installed and secured to the steel sleeve (Item 3A) on both sides of wall.

THE WIREMOLD CO. - FS2R FlameStopper, FS4R FlameStopper

*Bearing the UL Classification Mark



FIRESTOP DEVICE FOR USE IN THROUGH-PENETRATION
FIRESTOP SYSTEMS. SEE UL DIRECTORY OF PRODUCTS
CERTIFIED FOR CANADA AND UL FIRE RESISTANCE DIRECTORY

FLAMESTOPPER WIRE FILL CAPACITIES FOR DATA/COMMUNICATIONS

CABLE TYPE	CABLE / WIRE SIZE	O.D.		FS2		FS4	
		Inches	[mm]	40% FILL	60% FILL	40% FILL	60% FILL
UNSHIELDED TWISTED PAIR	4-pair, 24 AWG Cat 3	0.190	[4.8]	47	71	208	312
	4-pair, 24 AWG Cat 5e	0.210	[5.3]	38	58	170	255
	4-pair, 24 AWG Cat 6	0.250	[6.3]	20	30	68	100
TELEPHONE	2-pair, 24 AWG	0.140	[3.6]	87	130	383	574
	25-pair, 24 AWG	0.410	[10.4]	10	15	44	67
	50-pair, 24 AWG	0.580	[14.7]	5	7	22	33
	100-pair, 24 AWG	0.700	[17.8]	3	5	15	22
	400-pair, 24 AWG	1.470	[37.3]	0	1	3	5
COAXIAL	RG58/U	0.195	[5.0]	45	67	197	296
	RG59/U	0.242	[6.1]	29	43	128	192
	RG62/U	0.242	[6.1]	29	43	128	192
	RG6/U	0.270	[6.9]	21	32	95	140
FIBER OPTIC	2 Count	0.180	[4.6]	52	79	231	347
	6 Count	0.210	[5.3]	38	58	170	255
	24 Count	0.400	[10.2]	10	16	46	70
	48 Count	0.450	[11.4]	8	12	37	55
	96 Count	0.560	[14.2]	5	8	23	35

FLAMESTOPPER WIRE FILL CAPACITIES FOR POWER WIRING

CABLE TYPE	CONDUCTORS		O.D.		FS2		FS4	
	QUANTITY	SIZE	Inches	[mm]	40% FILL	60% FILL	40% FILL	60% FILL
Copper Conductor Cable with XLPE/PVX insulation and PVC jacket	4	2	1.120	[28.45]	1	2	4	6
	3	2	1.020	[25.91]	1	2	5	8
	4	4	0.975	[24.77]	2	3	6	9
	3	4	0.890	[22.61]	2	3	7	11
	4	6	0.820	[20.83]	2	3	8	12
	3	6	0.745	[18.92]	3	4	10	15
	4	8	0.725	[18.44]	3	4	10	15
	3	8	0.660	[16.76]	4	5	12	19
Max 8 cond. No. 12 AWG MC (Metal Clad) Cable			0.375	[9.5]	12	18	53	80
			0.500	[12.7]	6	10	30	45
			0.625	[15.9]	4	6	19	28
			0.655	[16.6]	3	5	17	26

WIREMOLD



Wiremold / Legrand

U.S. and International:

60 Woodlawn Street • West Hartford, CT 06110

1-800-621-0049 • FAX 860-232-2062 • Outside U.S. 860-233-6251

Canada:

570 Applewood Crescent • Vaughan, Ontario L4K 4B4

1-800-723-5175 • FAX 905-738-9721

