

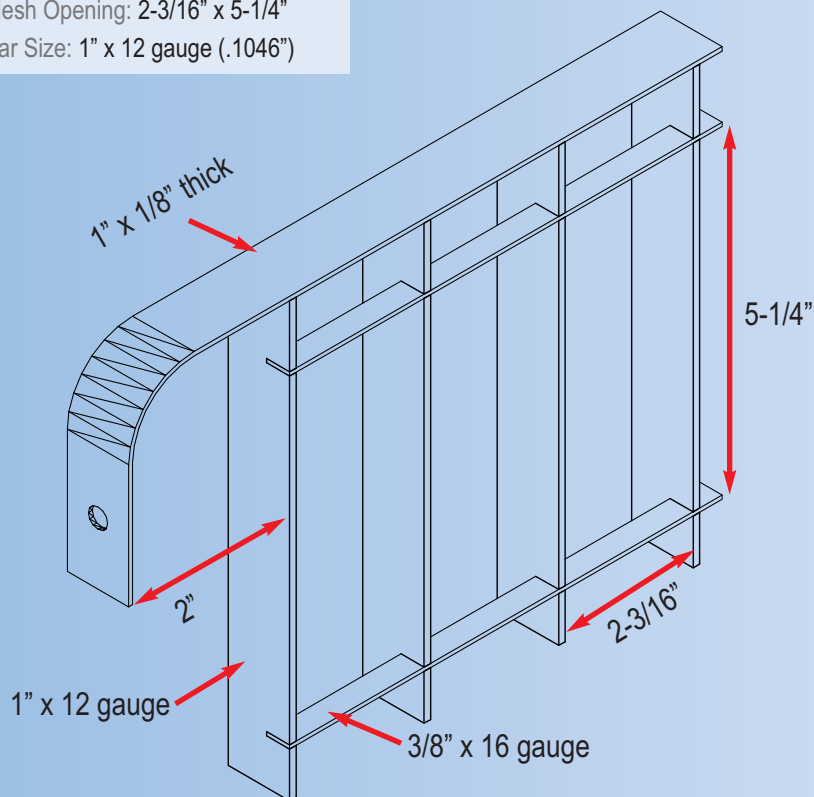

PRESSLOCK Urban

Urban

Mesh Opening: 2-3/16" x 5-1/4"
Bar Size: 1" x 12 gauge (.1046")



We are proud to offer our **NEW** architectural **PressLock** steel fence, ideal for multiple uses where aesthetics and security need to co-exist.

- **Strong and Long-Lasting**
- **Nearly Maintenance FREE**
- **No Surface Cracking or Fading**
- **Galvanized and /or Powder Coated**

Urban is manufactured using an exclusive pressure lock process, giving complete penetration of the cross member, a technique that is both functional and decorative. It then receives a galvanized finish with a polyester powder coating giving it the best corrosion protection available. **Urban** is both strong and attractive.

Specifications:

PressLock steel fencing. MBG **Urban** design: 1" x 12 gauge main bar, 3/8" x 16 gauge cross bar, 2-3/16" x 5-1/4" mesh. Galvanized to ASTM 123 and /or polyester powder coated 2.40 lbs./sq. ft.

We can custom manufacture and fabricate most mesh sizes or panel configurations required. Contact one of our sales representatives today at **1-800-321-9800** and we'll design a system exclusively for you!

How to Specify...

| "H" Panel Height | "A" Anchorage Depth | Post Size |
|---------------------|---------------------------|----------------|
| 36" | 8" | 2-1/2" x 5/16" |
| 48" | 8" | 2-1/2" x 5/16" |
| 60" | 10" | 2-1/2" x 5/16" |
| 72" | 12" | 3" x 5/16" |
| 96" | 14" | 3" x 5/16" |

| "P" Post Centers | "U" Unit Width | "W" Grille Width | "M" Mounting Projection |
|---------------------|-------------------|---------------------|-------------------------------|
| 48-7/16" | 48-1/4" | 43-7/8" | 2" |
| 77" | 76-11/16" | 72-5/16" | 2" |

NOTE: These are standard panel sizes and grilles. OGI can custom manufacture and fabricate any size mesh or panel configuration required. Contact our sales team for assistance at 800-321-9800 or visit us online at www.ogifence.com to locate your nearest representative.

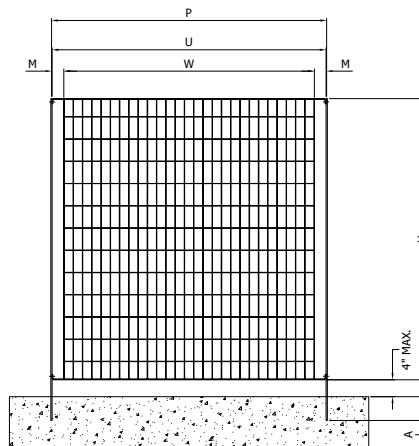

Zinc Rich Primer ...

Offers an Outstanding Corrosion Control Alternative to Hot-Dip Galvanizing

Zinc Rich Primer was developed to provide outstanding corrosion control for steel and is ideal for prime coat and protecting substrates from corrosion prior to being topcoated.

Since *Zinc Rich Primer* is an epoxy powder coating that accepts water or solvent borne and various other powder coating topcoats, it requires a topcoat for protection against U.V. radiation for best results.

Expect the highest quality of corrosion resistance when surfaces are properly treated, thorough rinse stages are used and all curing methods are observed correctly.

- *Outstanding Corrosion Resistance*
- *Works Well with Other Topcoats*
- *Add Years to Metal Fence Longevity*
- *Easier to Use than Hot-Dip Galvanizing*

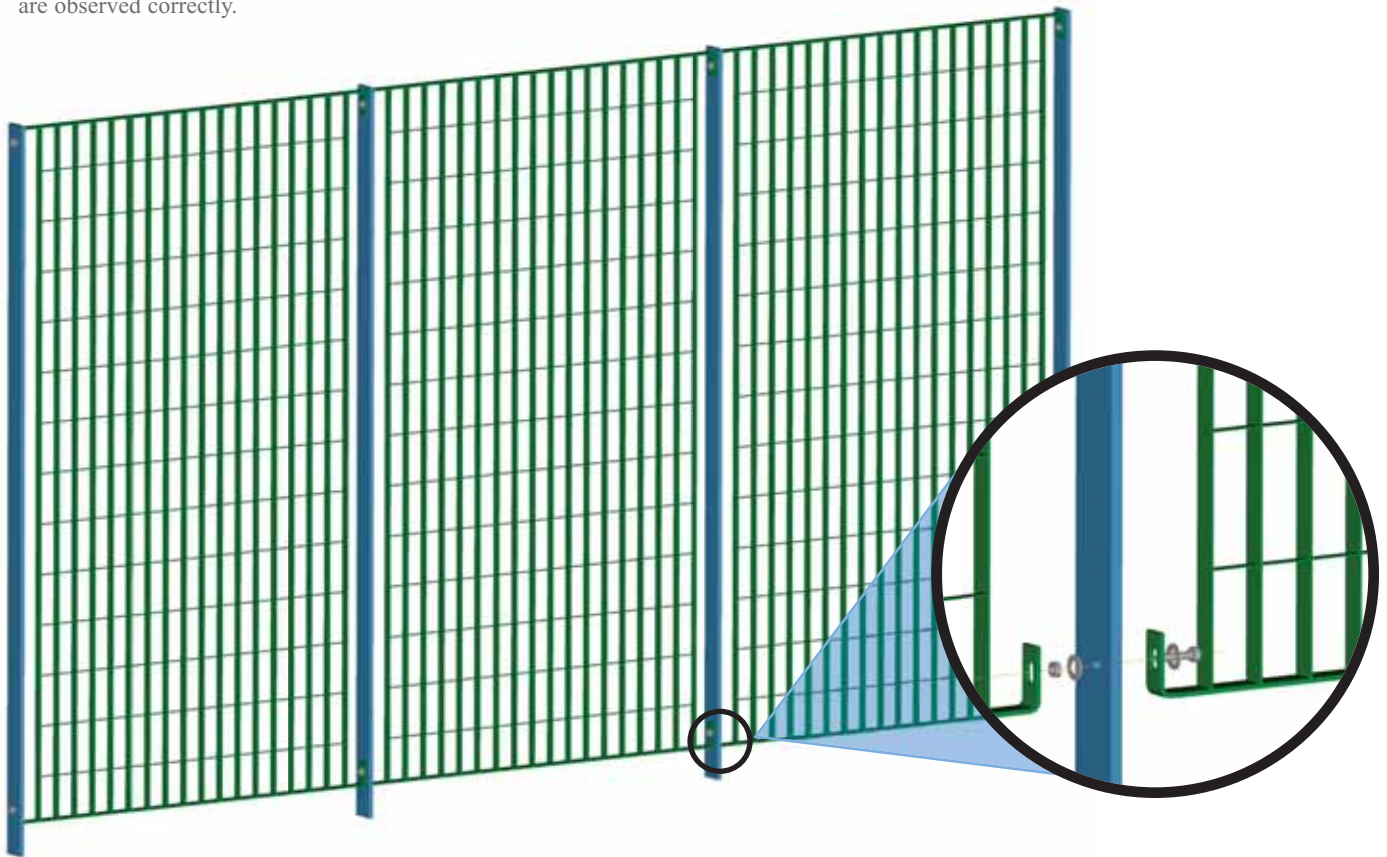

Urban

Zinc Rich Primer Test Results 7520-70138

| ATTRIBUTE | TEST METHOD | RESULT |
|--------------------------------|---------------------------------------|--|
| Color | Visual | Gray |
| Dry Film Thickness | ASTM D 1186-93 | 2.0 - 3.0 mils |
| Gloss @ 60 | ASTM D 523-94 | 10- 60% |
| Cross Hatch Adhesion | ASTM D 3359-95B | 5B |
| Flexibility (conical mandrel) | ASTM D 522-93aA | No Cracking |
| Hardness | ASTM D 3363-92a | H - 5H |
| Impact Resistance | ASTM D 2794-93 Direct Reverse | 100 inch - lbs. No Cracking 100 inch - lbs. No Cracking |
| Gravelometer (chip resistance) | ASTM D 3170-91 (SAE j400) | 5A |
| Humidity Resistance | ASTM D 2247-94 (>6000 hours*) | No Loss of Adhesion, Blister grade 10 |
| Salt Spray Resistance | ASTM D 117-94 (>6000 hours* X-Scribe) | < 2mm Creep, Blister grade 10 |

NOTE: *Testing was performed on *Bondrite® 1000 Parcolene® 60* panels. The highest quality powder coating finish results from proper substrate surface preparation, appropriate pre-treatment, effective rinse stages, proper powder coating application and sufficient temperature and dwell to ensure the powder coating is cured. Performance characteristics may be affected by operations exhibiting parameters different from the parameters utilized to generate this data. Therefore, we strongly recommend testing be performed utilizing substrate surface preparation, pretreatment, rinse, powder coating application and cure respective of one's operation to determine whether this product meets the desired requirements. *Bondrite®* and *Parcolene®* are registered trademarks of *Henkel Surface Technologies*.