

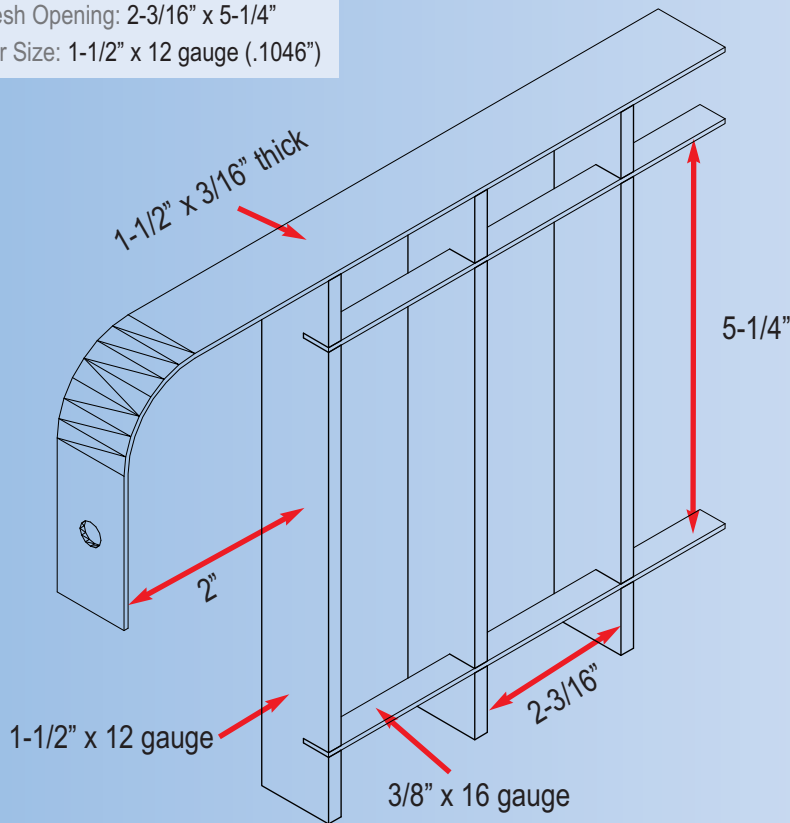

PRESSLOCK SafeGuard

SafeGuard

Mesh Opening: 2-3/16" x 5-1/4"
Bar Size: 1-1/2" x 12 gauge (.1046")



We are proud to offer our **NEW** architectural **PressLock** steel fence, ideal for multiple uses where aesthetics and security need to co-exist.

- *Strong and Long-Lasting*
- *Nearly Maintenance FREE*
- *No Surface Cracking or Fading*
- *Galvanized and /or Powder Coated*

SafeGuard is manufactured using an exclusive pressure lock process, giving complete penetration of the cross member, a technique that is both functional and decorative. It then receives a galvanized finish with a polyester powder coating giving it the best corrosion protection available. **SafeGuard** is both strong and attractive.

Specifications:

PressLock steel fencing. MBG **SafeGuard** design: 1-3/16" x 14 gauge main bar, 3/8" x 16 gauge cross bar, 2-3/16" x 5-1/4" mesh. Galvanized to ASTM 123 and /or polyester powder coated 3.49 lbs./sq.ft.

We can custom manufacture and fabricate most mesh sizes or panel configurations required. Contact one of our sales representatives today at **1-800-321-9800** and we'll design a system exclusively for you!

How to Specify...

"H" Panel Height	"A" Anchorage Depth	Post Size
36"	8"	2-1/2" x 5/16"
48"	8"	2-1/2" x 5/16"
60"	10"	2-1/2" x 5/16"
72"	12"	3" x 5/16"
96"	14"	3" x 5/16"

"P" Post Centers	"U" Unit Width	"W" Grille Width	"M" Mounting Projection
51-1/16"	50-5/8"	46-1/8"	2"
75-1/8"	74-11/16"	70-3/16"	2"

NOTE: These are standard panel sizes and grilles. OGI can custom manufacture and fabricate any size mesh or panel configuration required. Contact our sales team for assistance at 800-321-9800 or visit us online at www.ogifence.com to locate your nearest representative.

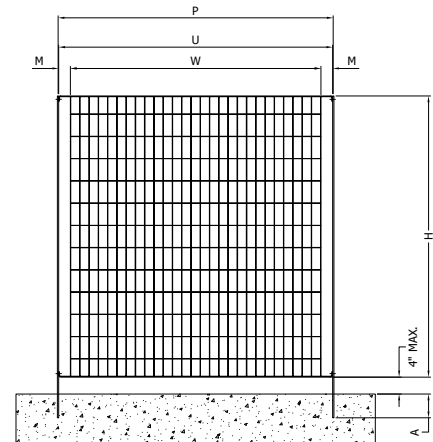

Zinc Rich Primer ...

Offers an Outstanding Corrosion Control Alternative to Hot-Dip Galvanizing

Zinc Rich Primer was developed to provide outstanding corrosion control for steel and is ideal for prime coat and protecting substrates from corrosion prior to being topcoated.

Since *Zinc Rich Primer* is an epoxy powder coating that accepts water or solvent borne and various other powder coating topcoats, it requires a topcoat for protection against U.V. radiation for best results.

Expect the highest quality of corrosion resistance when surfaces are properly treated, thorough rinse stages are used and all curing methods are observed correctly.

- Outstanding Corrosion Resistance
- Works Well with Other Topcoats
- Add Years to Metal Fence Longevity
- Easier to Use than Hot-Dip Galvanizing

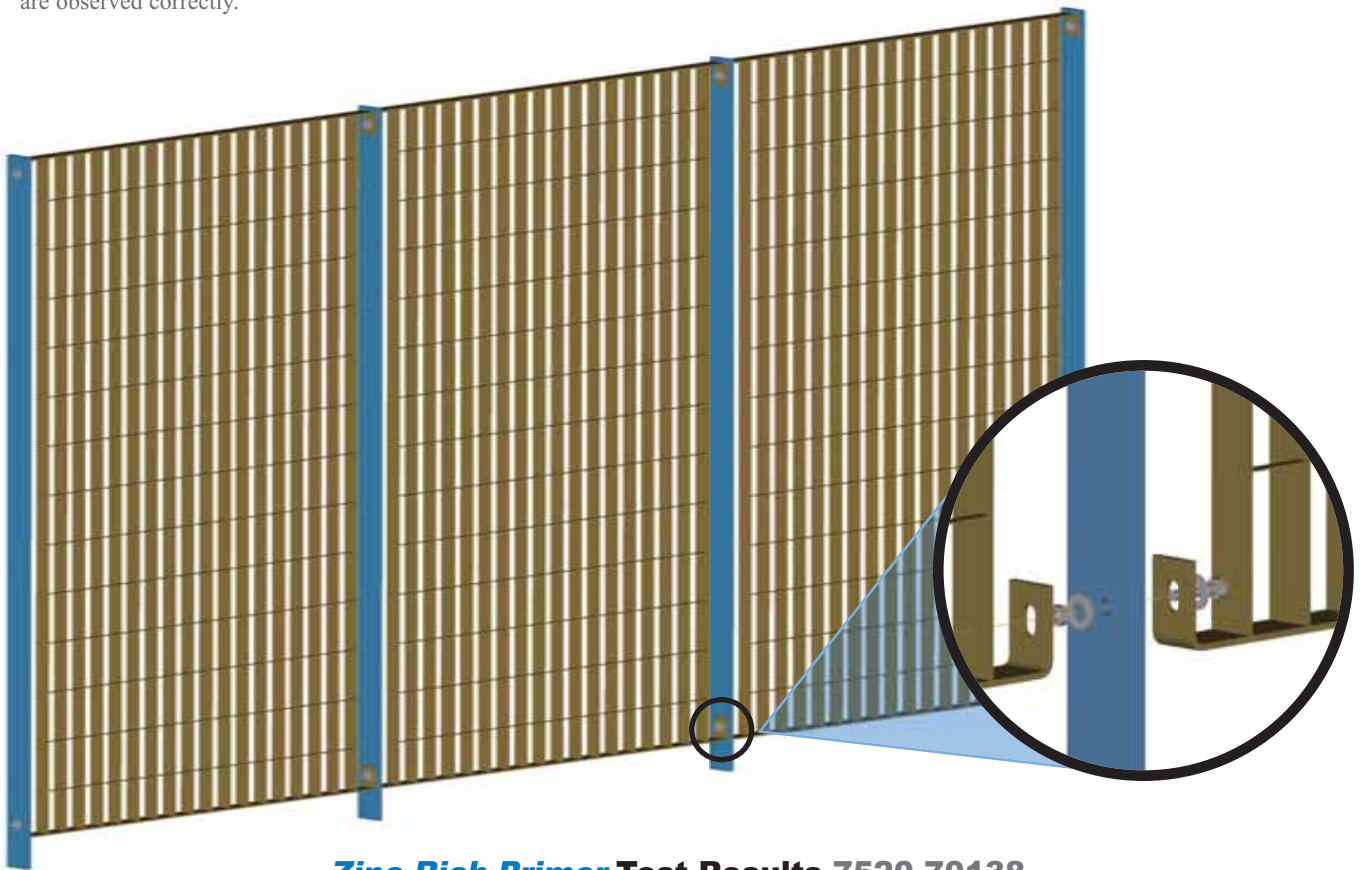

Safeguard

Zinc Rich Primer Test Results 7520-70138

ATTRIBUTE	TEST METHOD	RESULT
Color	Visual	Gray
Dry Film Thickness	ASTM D 1186-93	2.0 - 3.0 mils
Gloss @ 60	ASTM D 523-94	10- 60%
Cross Hatch Adhesion	ASTM D 3359-95B	5B
Flexibility (conical mandrel)	ASTM D 522-93aA	No Cracking
Hardness	ASTM D 3363-92a	H - 5H
Impact Resistance	ASTM D 2794-93 Direct Reverse	100 inch - lbs. No Cracking 100 inch - lbs. No Cracking
Gravelometer (chip resistance)	ASTM D 3170-91 (SAE j400)	5A
Humidity Resistance	ASTM D 2247-94 (>6000 hours*)	No Loss of Adhesion, Blister grade 10
Salt Spray Resistance	ASTM D 117-94 (>6000 hours* X-Scribe)	< 2mm Creep, Blister grade 10

NOTE: *Testing was performed on *Bondrite® 1000 Parcolene® 60* panels. The highest quality powder coating finish results from proper substrate surface preparation, appropriate pre-treatment, effective rinse stages, proper powder coating application and sufficient temperature and dwell to ensure the powder coating is cured. Performance characteristics may be affected by operations exhibiting parameters different from the parameters utilized to generate this data. Therefore, we strongly recommend testing be performed utilizing substrate surface preparation, pretreatment, rinse, powder coating application and cure respective of one's operation to determine whether this product meets the desired requirements. *Bondrite®* and *Parcolene®* are registered trademarks of *Henkel Surface Technologies*.