

**R-5000 to R-5002 Series
Pressure Relief Valve**

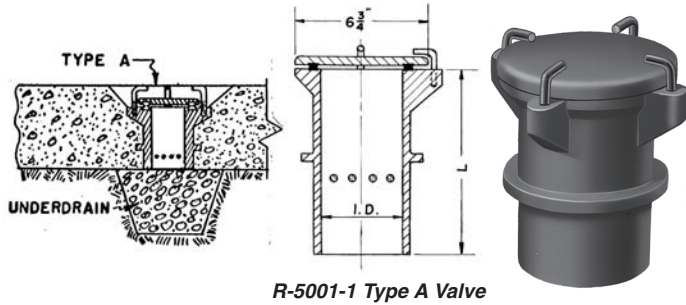

R-5001-1 Type A Valve

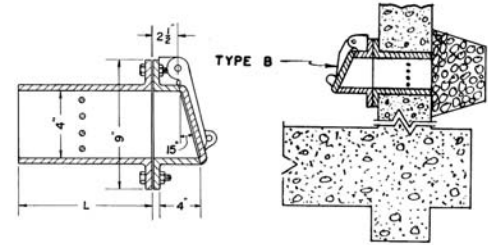

R-5002 Type B Valve

Pressure relief valves are suitable for sub-grade concrete tanks of all kinds. Outside water pressure forces the relief valve open and allows water to enter the tank. This tends to control buoyancy of the tank and prevents floating.

All valves furnished standard with neoprene seat mountings unless otherwise specified. Alternate bronze seat mounting available on special order. Specify length when ordering.

Dimensions in inches					
Catalog No.	Type	I.D.	Flange Dia.	Lid Dia.	Length
R-5000	C	4	6	6 3/4	10 to 25
R-5001	A	4	6	6 3/4	12
R-5001-1	A	6	8 1/4	8 1/2	12 to 26
R-5002	B	4	9	5	12 to 24

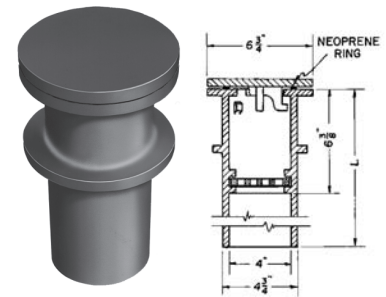

R-5000 Type C Self-contained lock, neoprene seating and removable grate

**R-5004 Series
Flanged Flap Valve**

Flap valves are used in areas where water accumulates, such as manholes or concrete boxes. When the manhole begins to fill, the flap valve can be opened to flush the area of water. The flap valve door has a tab with a hole located in the center to allow a handle to be attached so it can be opened from the surface.

Furnished standard with neoprene seat mounts. Bronze seat mounting is available on special order. All hinge pins are brass. Flanges are faced and drilled to 125 pound standard.

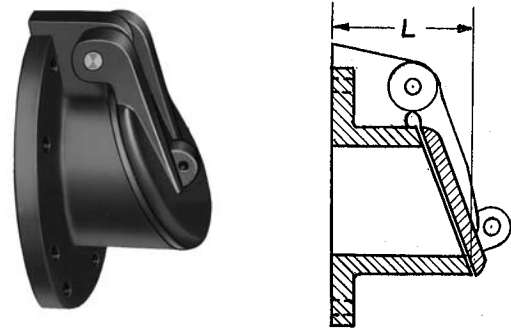

Dimensions in inches		
Catalog No.	Inside Dia.	Laying Length
R-5004-A1	4	4
R-5004-A2	6	4
R-5004-A3	8	7 1/2
R-5004-A4	10	5 1/2
R-5004-A5	12	8

R-5005 Series Shear Gates

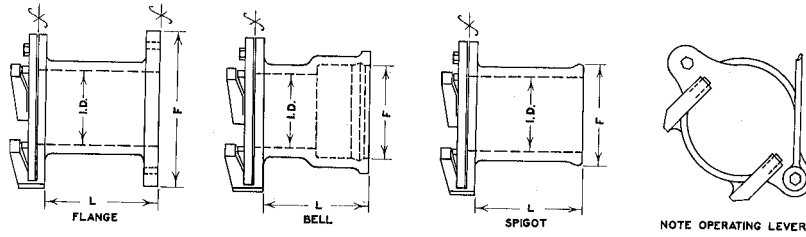

Shear gates are used as control applications for many installations, such as sewage disposal systems, where positive flow regulation is required. Contact surfaces between body and cover are machine finished. The gate hinge pins are stainless steel. Bronze seat mountings are also available on special order at extra cost.

NOTE: for use in Low Head applications only.

Flanges machine faced, diameters and bolt circles 125 pound standard.

Operating levers are optional and are available at any length.

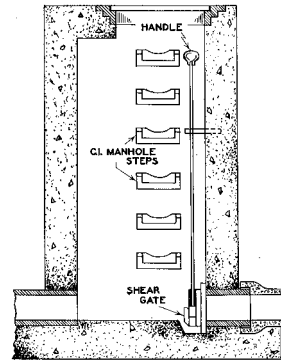

Bell End

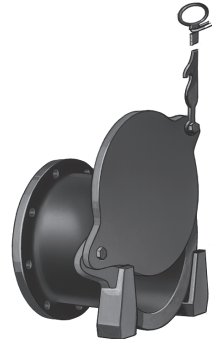

Flanged

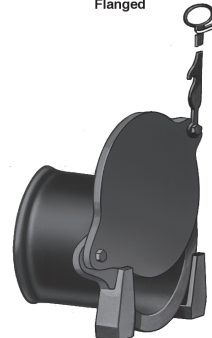

Spigot End

Catalog No.	Dimensions in inches			Type
	I.D.	L	F	
R-5005-A3	3	10	4 1/4	Spigot
R-5005-B1	4	4	9	Flanged
R-5005-B2	4	4	5 3/4	Bell
R-5005-B3	4	10	5 1/4	Spigot
R-5005-C1	6	4	11	Flanged
R-5005-C2	6	16	7 7/8	Bell
R-5005-C3	6	10	6 1/2	Spigot
R-5005-D1	8	5	13 1/2	Flanged
R-5005-D2	8	16	10	Bell
R-5005-D3	8	12	9 1/2	Spigot
R-5005-E1	10	6	16	Flanged
R-5005-E2	10	6	12	Bell
R-5005-E3	10	12	11 5/8	Spigot
R-5005-F1	12	6	19	Flanged
R-5005-F2	12	8 3/4	14 1/8	Bell
R-5005-F3	12	15	13 3/4	Spigot

**R-5040 Series
Flap and Flush Valve Frame, Lid**

Shown are some standard types of flap and flush valves. Flanged ends are faced and drilled to 125 pound standard.

Flush valves are used in areas where debris accumulates, such as manholes, concrete boxes or dead-end lines. When the manhole begins to fill, the valve can be opened to flush the area of water. The flush valve door has a tab with a hole located in the center to allow a handle to be attached so it can be opened from the surface.

Valves furnished with solid brass hinge pins; neoprene or bronze available on special order at extra cost. Chain furnished only when specified.

Dimensions in inches		
Catalog No.	I.D.	L
R-5040-F1	4	4
R-5040-F3	6	4 1/2
R-5040-F4	8	7 1/2
R-5040-F5	10	5 1/2
R-5040-F6	12	8
R-5040-F8 *	15	14

* Flange bolt circle for standard 16" class 125# pipe.

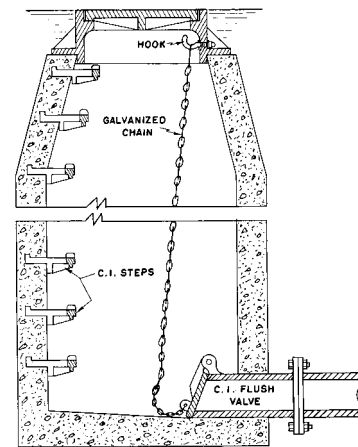
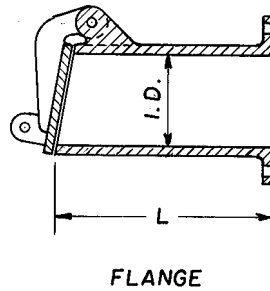

Manhole is filled with water and the valve then opened, flushing sewer. Chain furnished only when specified.

R-5050 Series Automatic Drainage Gate

Automatic drainage gates are used in areas with a requirement to prevent back flow, such as storm and sanitary sewer systems.

STANDARD GATES: Furnished with vertical closure for maximum ease of operation.

GENERAL INFORMATION: Gates are made of cast iron. All moving parts operate on stainless steel hinge pins. The cover is hung with cast iron arms (Ductile iron arms on larger sizes) located at the outer edges near the center of gravity to ensure sensitive operation. For improved seating, order with neoprene seat at extra cost.

Aluminum covers can be furnished for special requirements, if specified. Also available on special order and at extra cost are neoprene or solid bronze seat mounts and bronze bushed hinges.

For applications with extreme head pressure contact Neenah's Product Engineering Department.

Maximum head loss occurs when pipe is flowing full. Consider the head loss to be one-half the pipe diameter.

These flap gates are self-draining when no up-stream flow exists and no head is on the downstream side.

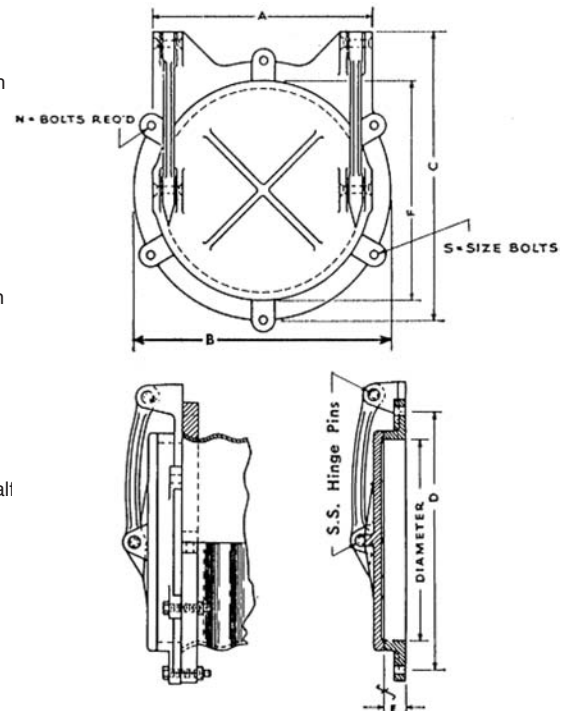

Dimensions in inches

Catalog No. Type SF	Catalog No. Type CF	Catalog No. Type FF	Diameter	A	B	C	D	E	F	N	S
R-5050-SF6	R-5050-CF6	R-5050-FF6	6	7	11	13	11	3/4	7	four	5/8
R-5050-SF8	R-5050-CF8	R-5050-FF8	8	9 1/4	11	13	11	1 1/8	9 1/4	four	5/8
R-5050-SF10	R-5050-CF10	R-5050-FF10	10	11 1/4	13 1/2	15 1/5	13 1/2	1 1/8	11 1/4	four	5/8
R-5050-SF12	R-5050-CF12	R-5050-FF12	12	13 1/4	15 7/8	18	15 3/4	1 1/8	13 1/4	four	5/8
R-5050-SF15	R-5050-CF15		15	16 1/4	19	21	18 3/4	1 1/8	16 1/4	four	5/8
R-5050-SF18	R-5050-CF18	R-5050-FF18	18	19 1/4	22 1/8	24 1/4	22 1/8	1 1/4	19 1/4	four	3/4
R-5050-SF20	R-5050-CF20	R-5050-FF20	20	22 1/4	25 1/8	27 1/4	25 1/8	1 1/4	22 1/4	four	3/4
R-5050-SF21	R-5050-CF21		21	22 1/4	25 1/8	27 1/4	25 1/8	1 1/4	22 1/4	four	3/4
R-5050-SF24	R-5050-CF24	R-5050-FF24	24	25 1/4	28 1/4	30 1/4	28 1/4	1 1/4	25 1/4	six	3/4
R-5050-SF27			27	28 1/4	31 1/4	33 1/4	31 1/4	1 1/4	28 1/4	six	7/8
R-5050-SF30	R-5050-CF30		30	31 1/4	34 1/4	36 1/2	34 1/4	1 1/4	31 1/4	six	7/8
R-5050-SF36	R-5050-CF36		36	37 1/2	41 1/2	43 1/2	41 1/2	1 3/8	37 1/2	six	7/8
R-5050-SF42	R-5050-CF42		42	43 1/2	47 1/2	49 1/2	47 1/2	1 3/8	43 1/2	six	7/8
R-5050-SF48	R-5050-CF48		48	49 1/2	54	56 1/2	54	1 1/2	49 1/2	six	1



Type SF attached to
concrete wall



Type CF attached to
corrugated metal pipe.
(not for use with helical CMP)



Type FF attached to
flanged iron pipe