

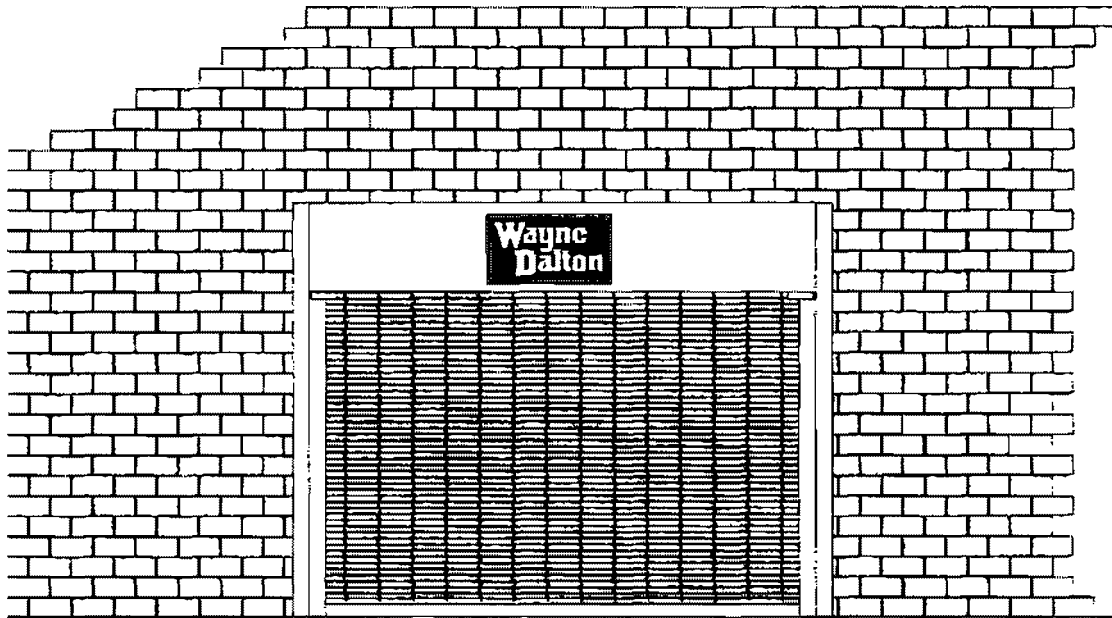

# Rolling Grilles

(Model 600 Series)

## Installation Instructions and Operation and Maintenance Manual



### **IMPORTANT NOTICE !!**

**READ THE ENCLOSED INSTRUCTIONS CAREFULLY BEFORE ATTEMPTING TO REMOVE EXISTING GRILLE OR INSTALLING THIS GRILLE. PAY CLOSE ATTENTION TO ALL WARNING LABELS AND THE IMPORTANT SAFETY NOTICES ON THE FOLLOWING PAGE.**

**THIS MANUAL MUST BE ATTACHED TO THE WALL IN CLOSE PROXIMITY OF THE GRILLE.**



## IMPORTANT SAFETY NOTICES

[Read the enclosed instructions carefully before attempting installation. If there are any questions about any of the procedures, do not perform the work. Instead, have a qualified door agency do the installation or repairs.]

1. Operate the grille **ONLY** when properly adjusted and free of obstructions.
2. Grille is constantly under **EXTREME SPRING TENSION**. Repairs, adjustments, installation and removal of bolts, springs, brackets, or curtain assemblies are dangerous so that such work should be performed **ONLY** by qualified door service people.
3. **DO NOT PERMIT** children to play with the grille or the electrical controls. The child could get caught between the grille and floor causing fatal injury.
4. If the grille is now or later becomes electrically operated, any locking devices **MUST** be disengaged or electrically interlocked.
5. Avoid standing in the path of the grille while grille is moving. One could get caught between the grille and floor or counter top causing fatal injury.
6. Should grille become hard to operate or completely inoperative, it is recommended that a qualified grille agency correct the problem to prevent any accident or injury.
7. Avoid installing grille on windy days. The grille could fall causing an accident or injury.
8. Frequently check all bolted connections to make sure they are secure during the lifetime of the grille to prevent injuries and accidents due to loose connections.
9. To avoid injury, never place hands or fingers between the gears, chain and sprockets, while the grille is being operated. Otherwise, broken bones or serious lacerations could occur by pinching the hands or fingers.
10. This manual is not intended to direct "take-down" procedures of existing grilles. Consult your local door authority if this is required before new grilles are to be installed.
11. Thoroughly familiarize yourself with the construction codes required in the region where the grille is to be installed before initiating work.
12. Wear the proper safety clothing and protective safety gear as needed.
13. Crew chiefs should consider using a 2-person (or larger) crew for larger grilles.
14. Definition of key words used in this manual are as follows:

 **WARNING** - Indicates a potential hazardous situation which, if not avoided, could result in serious injury or death.

 **CAUTION** - Alerts against unsafe practices and potential property damage accidents.

**IMPORTANT!** - Required step for safe and proper door operation.

**NOTE:** -- Information assuring proper installation of the door.

**HINT:** -- Suggested step to simplify installation based on experience.



## Model 600 Rolling Grille Limited Warranty

Wayne Dalton, a division of Overhead Door Corporation ("Seller") warrants to the original purchaser of the Model 600 Rolling Grille ("Product"), subject to all of the terms and conditions hereof, that the Product and all components thereof will be free from defects in materials and workmanship for the following period(s) of time, measured from the date of installation:

- **12 MONTHS** against defects in materials and workmanship

Seller's obligation under this warranty is specifically limited to repairing or replacing, at its option, any part which is determined by Seller to be defective during the applicable warranty period. Any labor charges are excluded and will be the responsibility of the purchaser.

This warranty is made to the original purchaser of the Product only, and is not transferable or assignable. This warranty does not apply to any unauthorized alteration or repair of the Product, or to any Product or component which has been damaged or deteriorated due to misuse, neglect, accident, failure to provide necessary maintenance, normal wear and tear, acts of God, or any other cause beyond the reasonable control of Seller or as a result of having been exposed to toxic or abrasive environments, including blowing sand, salt water, salt spray and toxic chemicals and fumes.

THIS WARRANTY IS EXCLUSIVE AND IN LIEU OF ANY OTHER WARRANTIES, EITHER EXPRESS OR IMPLIED, INCLUDING BUT NOT LIMITED TO ANY IMPLIED WARRANTY OF MERCHANTABILITY OR FITNESS FOR A PARTICULAR PURPOSE.

IN NO EVENT SHALL SELLER BE RESPONSIBLE FOR, OR LIABLE TO ANYONE FOR, SPECIAL, INDIRECT, COLLATERAL, PUNITIVE, INCIDENTAL OR CONSEQUENTIAL DAMAGES, even if Seller has been advised of the possibility of such damages. Such excluded damages include, but are not limited to, loss of use, cost of any substitute product, or other similar indirect financial loss.

Claims under this warranty must be made promptly after discovery, within the applicable warranty period, and in writing to the authorized dealer or installer whose name and address appear below. The purchaser must allow Seller a reasonable opportunity to inspect any Product claimed to be defective prior to removal or any alteration of its condition. Proof of the purchase and/or installation date, and identification as the original purchaser, may be required.

SELLER: \_\_\_\_\_

SELLER'S ADDRESS: \_\_\_\_\_  
\_\_\_\_\_

# Rolling Grille

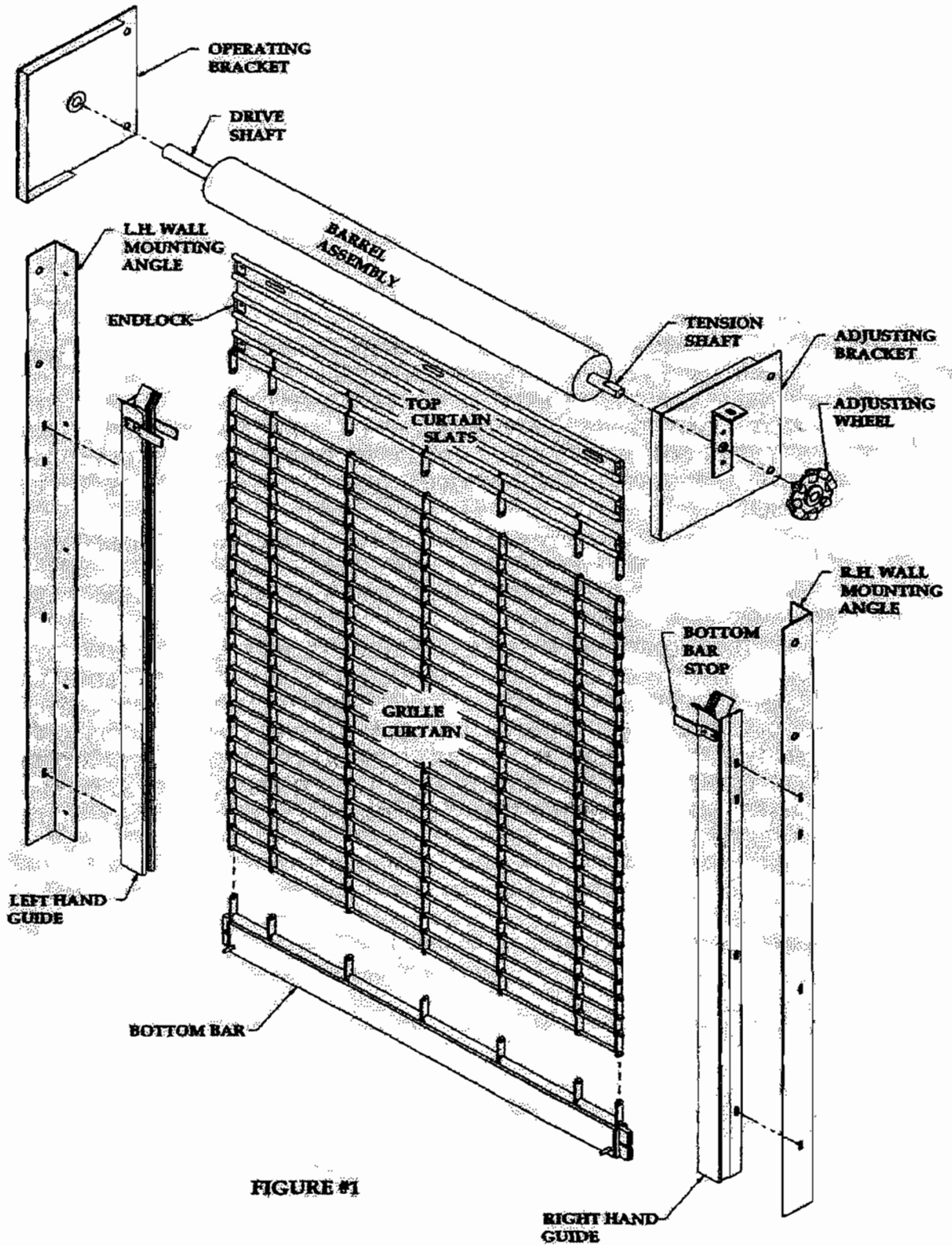

# Table of Contents

	Page
<b>About this manual</b> .....	i
<b>Preparation</b> .....	i
<b>Grille Components and Hardware</b> .....	ii
<b>Step 1: Opening Checks</b> .....	1
<b>Step 2: Guide Mounting</b> .....	2
<b>Step 3: Attaching Curtain to Barrel Assembly</b> .....	8
<b>Step 4: Attaching Brackets to Wall Angles</b> .....	10
<b>Step 5: Applying Tension</b> .....	14
<b>Step 6: Testing Grille Balance</b> .....	16
<b>Step 7: Installing Hoods &amp; Hood Supports</b> .....	19
<b>Step 8: Miscellaneous Final Checklist</b> .....	20
<b>Optional Components</b> .....	Appendix A
<b>Service Record</b> .....	Appendix B
<b>Trouble Shooting</b> .....	Appendix C
<b>Emergency Egress Assembly</b> .....	Appendix D
<b>Compound Tension Adjuster Assembly</b> .....	Appendix E

## INTRODUCTION

This manual's main function is to assist the installer in correctly mounting grilles with due regard for safety, operation, and sound construction practices. Reference should be made to construction codes in your area.

All Wayne-Dalton Rolling Grilles follow the general guidelines set forth herein. Additional installation information for each grille shipped is found in the packing slip and supplementary drawings. There are also bolt and small parts bags sealed separately with accessory lists describing what part goes where.

## PREPARATION

Read the installation instructions to become familiar with the names of the various components and their relation to each other. It is a necessity for the installer to determine the following:

- The type of mounting (face mounted or between jambs mounted).
- Method of operation (hoist, crank, motor, or push-up).
- The hand of operation determined from the coil side (right or left).
- Type of jamb (masonry or steel) on which the grille guides mount and the fasteners required.
- The dimensions for the opening width, opening height, head room, and side room.

## MATERIAL

Inspect your door prior to leaving for the job site for possible damage or shortage of parts. Report any claims or shortages to your door supplier immediately.

## CLEARANCES

The installation drawings supplied in the hardware bag contain information on bracket size and head and side room for each grille. Be sure that the dimensions are correct for the opening you are working on. Take special note of the "C" dimension (FIG 4). **THIS DIMENSION MUST BE HELD IN ORDER TO PREVENT INTERFERENCE WITH THE PROPER OPERATION OF THE GRILLE WHILE BEING CLOSED.** Be sure the required clearances are available prior to installation.

## TOOLS

The tools recommended for proper installation of each door will vary, but commonly used tools are:

- Electric drill with 3/8" or 1/2" chuck.
- Masonry drill or impact hammer and bits.
- Chain hoist and sling for raising barrel and curtain assembly.
- Ladders and/or scaffolding.
- Wrenches, screwdrivers, hammer, level, drills, center punch, tape measure, chalk line, vise grips or C-clamps, water-level hose.
- Two hardened steel winding rods, 1/2" diameter and approximately 36" long.

# Section 1 - Supplied Parts List

## Major Components and Assemblies

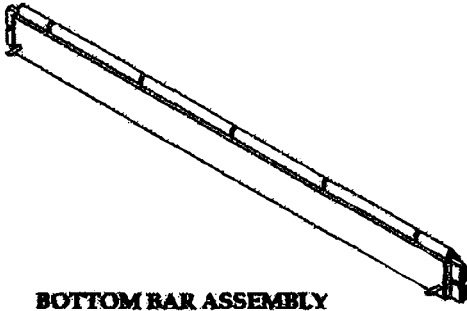

**BOTTOM BAR ASSEMBLY**

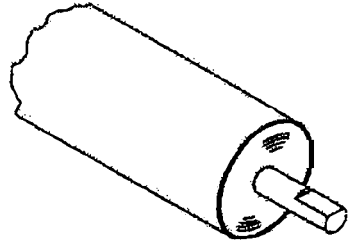

**BARREL ASSEMBLY**

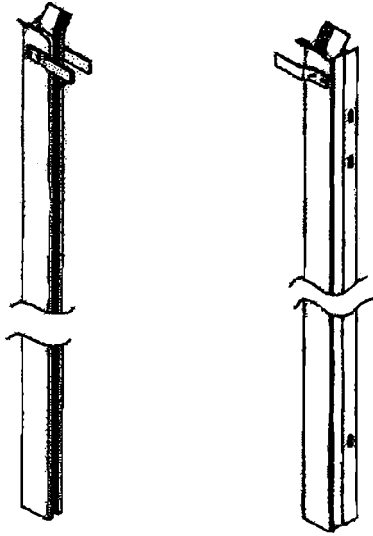

**GUIDE ASSEMBLY**

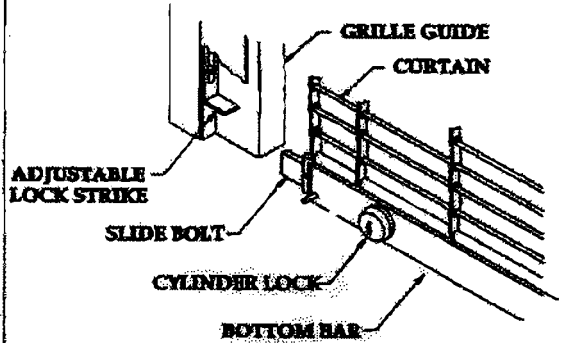

**CYLINDER LOCK OR  
SLIDE BOLT ASSEMBLY**

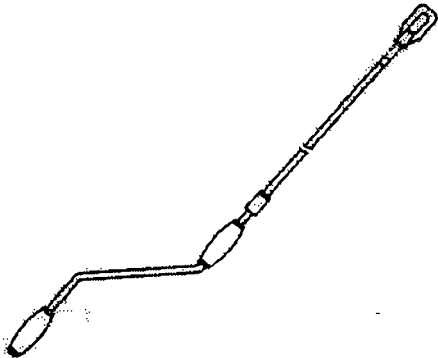



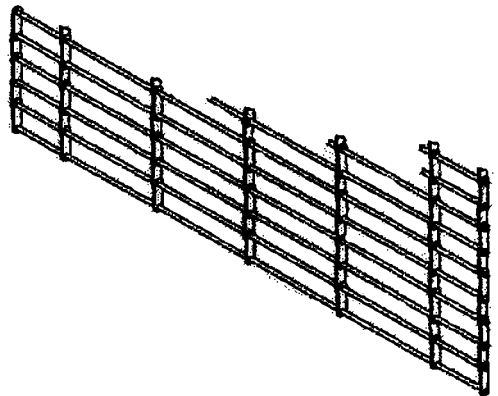

**AWNING CRANK WINDING SHAFT**

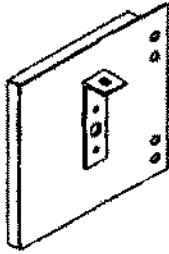
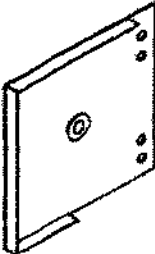

**CURTAIN ASSEMBLY**

# Section 2 - Supplied Parts List

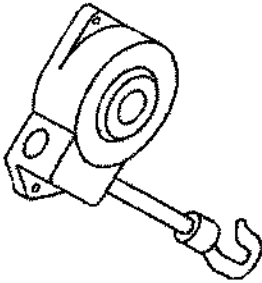
## Bracket Assemblies and Components

 <p><b>AW BRACKET ASSEMBLY</b></p>	 <p><b>OPERATOR BRACKET ASSY</b></p>	 <p><b>ADJUSTING WHEEL</b></p>
 <p><b>AWNING CRANK (IF REQD)</b></p>	 <p><b>BOTTOM BAR STOP</b></p>	



# Section 3 - Supplied Parts List

## Miscellaneous Components and Hardware

Also included is a bag of hardware with a packing slip to show where each piece is used. Below is an example including a ruler for you convenience :

<u>No/Door</u>	<u>Part Number</u>	<u>Description</u>	<u>Where Used</u>
4	004-1521-10	Grille Bottom Bar Stops (Mill Fin)	
2	016-0696-09	Tube base : For 3"x3" Tubes	
1	101-0051-04	Guide Installed Safety Sticker	
1	806-0071-05	1/2" x 1-3/4" Round Head Rivet	AW to Bracket
8	801-0785-05	3/8"-16 x 3/4" FH Mach Screw	Brackets to Tubes
4	805-0104-04	3/8" x 2-3/4" Wedge Anchors	Tube Bases to Floor
14	803-1854-05	5/16" x 1" Tek Screws	Guides to Tube
8	801-1410-05	1/4"-20 x 3/8" Truss Head Screws	BB Stops to Guides
5	801-1467-05	5/16"-18 x 1" Truss Hd Screw	Top Slat to Ring
5	802-0002-05	5/16"-18 Hex Nut	Top Slat to Ring
5	804-0025-05	5/16" Flat Washer	Top Slat to Ring

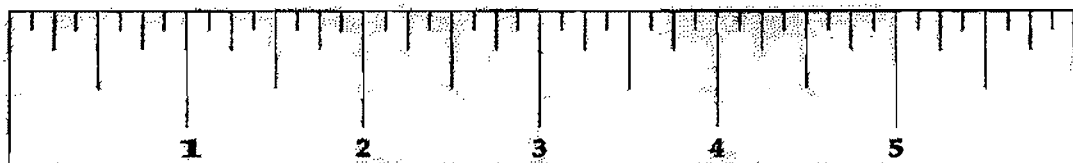

# Step 1: Opening Checks

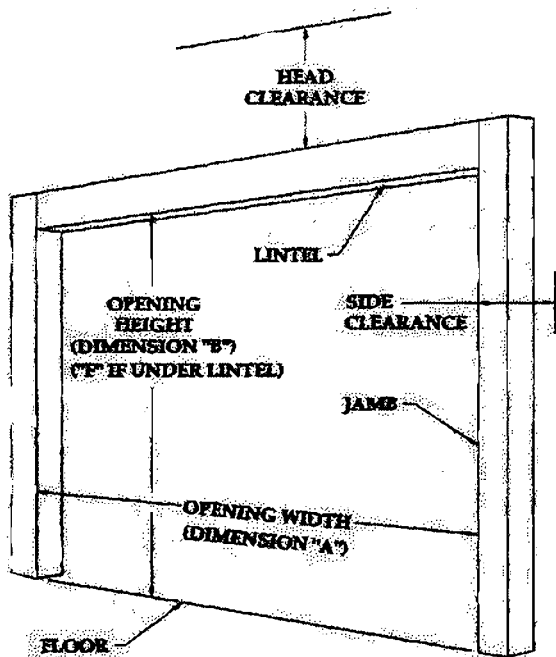

**FIGURE 42**

Refer to Figure 2. Check the opening width "A" and the opening height "B" or "F" and compare with the installation drawing to be sure the opening is the proper size for the grille. Any variations in the actual opening width or height, or plumbness of the jambs is to be disregarded when installing the guides. Verify the clearances available meet or exceed those given on the installation drawing.

**NOTE:** Unpack and lay out all grille components (prior to leaving for the job site, if possible) and review the following:

1. Does barrel hand of operation match the required hand on the drawings?
2. Do guide mounting angles match the required arrangement for masonry or steel?
3. Are all "extras" included such as safety edge, emergency egress, etc.

If **no** is the answer to any of these questions, stop and check with the factory for clarification before proceeding.

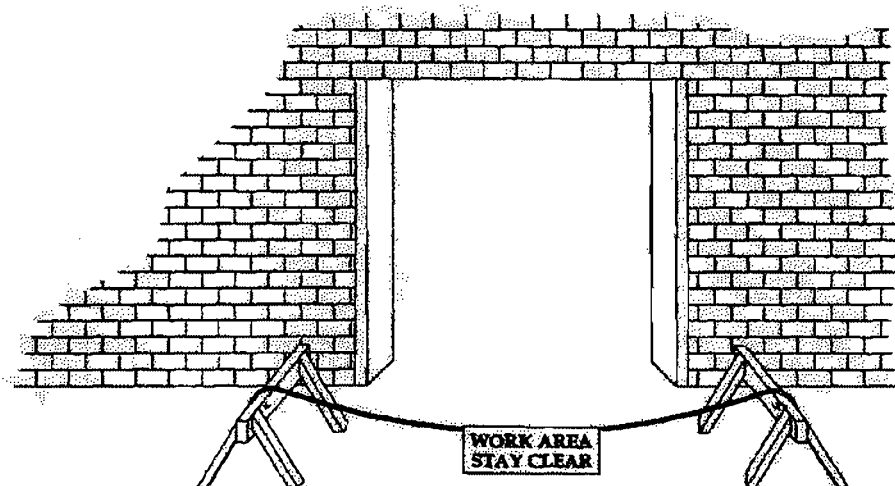

Rope off the opening prior to beginning work!

## Step 2 : Guide Mounting

2a. Face Mounted Grille (Brackets Above Lintel) (skip to Step 2b if grille is "between jambs mounted" ie., brackets below lintel)

Refer to Figure #4. Obtain the "C" dimension from the installation drawing and record below. With the guides on the floor, measure the distance from the inside of the left guide to the centerline of the slots on the wall angle (dimension "M") and record below. Repeat for dimension "M" for the right guide and record below. On masonry jambs (with wall mounting leg turned out, or "Z" guide), add both "M" dimensions to the "C" dimension to obtain the bolt line ("BL") dimension. On steel jambs (with the wall mounting leg turned in, or "E" guides), subtract both "M" dimensions from the "C" dimension to obtain "BL".

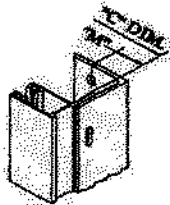

FIGURE #3

"C" Dimension (from Dwg) \_\_\_\_\_

"M" (Left Guide) \_\_\_\_\_

"M" (Right Guide) \_\_\_\_\_  
 (+ Masonry jamb, - Steel jamb)

Bolt line (BL) \_\_\_\_\_

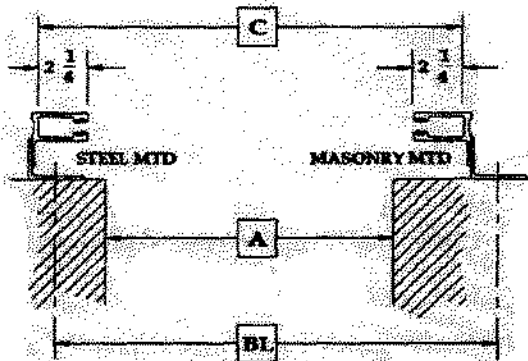

FACE MOUNTED GUIDES

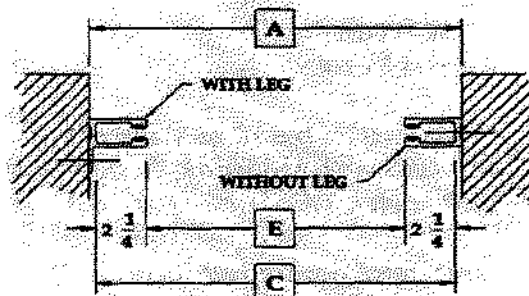

BETWEEN JAMBS MOUNTED GUIDES

FIGURE #4

To transfer the location of the bolt line ("BL") for the guide mounting bolts on the wall, first locate and mark the center of the opening above the lintel (see Figure #5). Divide BL in half ( $BL/2$ ) and measure this distance either side of the opening center mark to obtain the bolt line on each jamb. Drop a plumb line down and make a second mark on the wall at the bottom of each jamb. Using a chalk line, snap a vertical line the length of the "F" dimension (see installation drawing).

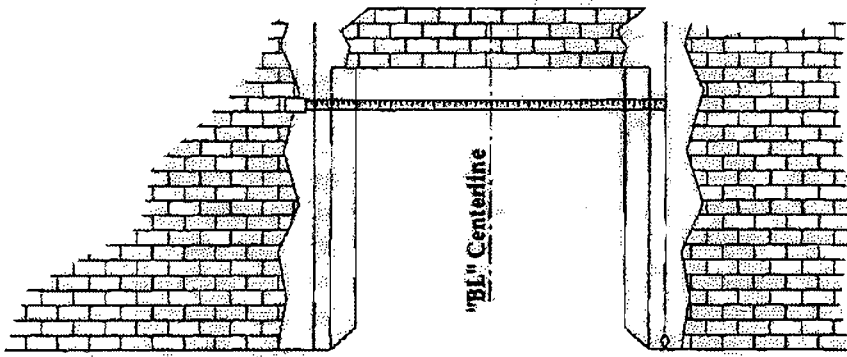

**FIGURE #5**

**⚠ WARNING - THE GUIDE ASSEMBLIES CAN BE EXTREMELY HEAVY. PERSONS WITH BACK PROBLEMS OR OTHER PHYSICAL CONDITIONS WHICH MAY LIMIT THEM FROM LIFTING HEAVY OBJECTS SHOULD NOT PERFORM THIS NEXT STEP.**

Below is a chart listing the weight (in pounds) for each jamb's guide component to be used for reference in prudent handling:

Guide Piece	Clear Opening Height			
	8'	10'	16'	20'
Alum Extr Only	11	13	20	25
Wall Angle	21	26	120	160
3x3x1/8 Tube				95
4x4x1/8 Tube				129
4x4x1/4 Tube				244

\*This chart is based on standard products. Special guide angles or unusual mounting conditions do not apply. In the event that the opening falls between sizes, use the next higher size.

Next, temporarily but securely clamp or hold the guides to jamb, carefully aligning center of holes along the chalk "bolt line". After determining guides are plumb, level and properly spaced, scribe the location of the guide mounting holes on each jamb.

**NOTE: IF FLOOR IS NOT LEVEL, MARK ON JAMB WHERE FLOOR OR COUNTER TOP SHOULD BE IF IT WERE LEVEL. SHIM GUIDE TO THIS MARK PRIOR TO SCRIBING GUIDE HOLE LOCATIONS.**

**HINT: A water level is very handy to determine if the floor is level. Scribe a mark at each jamb corresponding to the water level. Measure from these marks to the floor. If distances are equal, floor is level. If not, shim as stated above.**

Remove the guides and drill (or tap) the appropriate size mounting holes for the fasteners provided (listed as "Guides-to-Wall" on hardware shipping list) at each hole location.

**NOTE: DO NOT** attach the bottom bar stops at this time, as it will prevent the bottom bar from passing through the top of the guides.

If wall mounting angle has been dis-assembled for ease of erection, be sure to re-assemble and maintain all relative dimensions (such as groove depth, "C" dimension, etc.). Install top and bottom bolts in both guides with hardware provided. Check the "C" at several points and compare with the installation drawing.

**IMPORTANT! CONSULT PLANS OR SPECS FOR FINISHED FLOOR ELEVATION AND BE SURE TO ALLOW FOR THIS SPACE SHOULD THE INSTALLATION REQUIRE IT. THIS SPACE ALLOWANCE IS PARTICULARLY IMPORTANT IF LOCKS ARE REQUIRED.**

**IMPORTANT! THE GUIDE TO GUIDE DISTANCE, OR "C" DIMENSION ON THE INSTALLATION DRAWING MUST BE HELD. (See Figure #4.)**

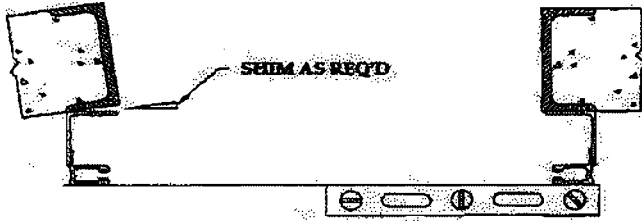

**FIGURE #6**

Using a string and a level, ensure that the guides are parallel to each other, shimming if necessary to achieve vertical and horizontal leveling. Now install the remaining bolts.

**IMPORTANT! USE OF ANY OTHER TYPE FASTENER THAN THOSE PROVIDED MUST BE APPROVED BY MANUFACTURER OR LOCAL BUILDING AUTHORITY AND CANNOT BE OF A LESSER DIAMETER OR GRADE**

## Step 2b: Between Jamb Mounted Grilles

### Guides Mounted To Tubes

Some between jamb grilles require square tubes between the wall and guide assembly, or are used as structure where no wall is available. Locate the tubes with respect to the "A" dimension on the installation drawing.

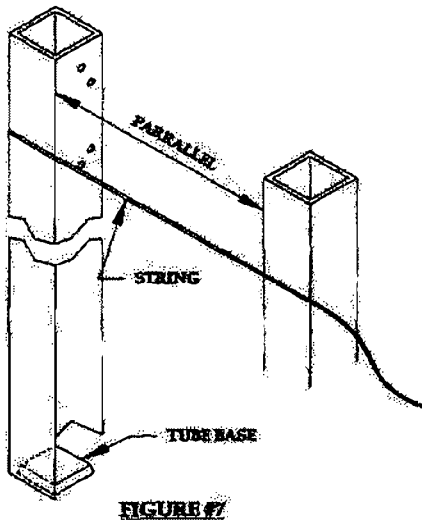

The tubes must be square with each other, plumb and level (see Figure #7). Tubes are marked LH or RH but may be determined by the following:

The mounting holes for the brackets consist of a 4-hole pattern. The two holes that are closer together are toward the OPPOSITE COIL SIDE of the grille.

After determining the location of the tube, mark the outside of the tube on the floor. Center the tube base in the marks and scribe the location of the tube base mounting holes. Bolt the tube base to the floor with the anchors provided. Set the tube over the base and level as required. Attach the top of the tube to the ceiling structure as required.

Locate guide on the tube (FIG. 8) flush with the edge of the tube (may vary-verify with installation drawing).

Install the TEK screws in the center of ALL the slots in the aluminum extrusion.

**NOTE:** Do not attach the bottom bar stops at this time, as it will prevent the bottom bar from passing through the top of the guides.

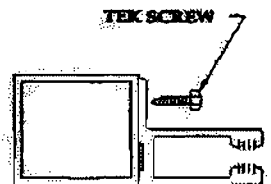

FIGURE #8

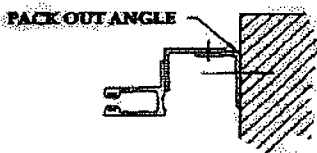

FIGURE #9

Guides without mounting leg are generally centered on the tube (see installation drawing for exceptions), and are installed with flat head screws through the center of the guide.

### Guides Mounted to Extra "Packout" Angle:

Sometimes a second angle (sometimes called the "packout" angle) may be provided with the guide assembly (see Figure #9). Unbolt this angle from the guide assembly (if supplied by factory).

**NOTE:** The extra angles are seldom the same size (RH vs LH) and when unbolted must be re-attached to the correct side. Mark "L" or "R" on the angle leg that mounts to the wall to avoid confusion later.

Next, determine the location of the "bolt line" (BL) for the guide mounting bolts on the wall. (Follow this procedure for either masonry or steel jambs.) Mark the top of the jamb where the BL is to be located and drop a plumb line to the bottom of the jamb. Mark a point there, and snap a chalk line between these two points. Repeat this procedure for the opposite jamb making sure the BL is exactly the same distance into the opening.

Choose one "packout" angle to be used as a template. Temporarily clamp the angle in the proper jamb (ie, left angle in left jamb) aligning the center of the holes with the chalk line. After determining that the "packout" angle is plumb, level and properly spaced into the opening, carefully scribe the location of each guide mounting hole on the jamb.

Repeat this procedure for the opposite side making sure that the angle is located at exactly the same distance into the opening. Remove the packout angle and drill the appropriate size mounting holes for the fasteners provided (listed as "Guides-to-Wall" on hardware shipping list).

Re-attach the packout angle to the appropriate guide assembly.

**NOTE:** Do not attach the bottom bar stops at this time, as it will prevent the bottom bar from passing through the top of the guides. Install both the guide assemblies on each jamb starting with the top and bottom bolts using the hardware provided. Using a string and a level, ensure that the guides are parallel to each other, shimming if necessary to achieve vertical and horizontal leveling (see Figure #6). Now install the remaining bolts.

**IMPORTANT!** REFER TO THE INSTALLATION DRAWING PROVIDED FROM THE FACTORY. THE CORRECT "C" DIMENSION MUST BE HELD, AS THE IMPROPER "C" DIMENSION MAY PREVENT PROPER OPERATION OF THE GRILLE. (See Figure #4)

**IMPORTANT!** USE OF ANY OTHER TYPE FASTENER THAN THOSE PROVIDED MUST BE APPROVED BY MANUFACTURER OR LOCAL BUILDING AUTHORITY AND CANNOT BE OF A LESSER DIAMETER OR GRADE.

#### **Between Jamb Guides Directly to Wall:**

Determine the location of the "bolt line" (BL) for the guide mounting bolts on the wall. (Follow this procedure for either masonry or steel jambs.) Mark the top of the jamb where the BL is to be located and drop a plumb line to the bottom of the jamb. Mark a point there, and snap a chalk line between these two points. Repeat this procedure for the opposite jamb making sure the BL is exactly the same distance into the opening. Install the provided bolts into all slots in the guide extrusion.



**FIGURE #10**

## Step 2c. Alternate Welding Guide Assembly To Steel Jambs

On jambs with steel channels, welding of the guides is an approved method of installation providing it is done following the procedures set forth in this manual, and achieve the equivalent strength of each omitted bolt. Refer to Figure #11 for proper welding method of guides to steel jambs.

**IMPORTANT! THE INSTRUCTIONS LISTED BELOW MUST BE FOLLOWED CLOSELY. FAILURE TO DO SO MAY CAUSE THE GRILLE TO BE INOPERATIVE.**

**IMPORTANT! THE "C" DIMENSION MUST BE CAREFULLY CONFIRMED TO BE CORRECT BEFORE WELDING IS PERFORMED.**

Option 1: Welding on outside of wall angle

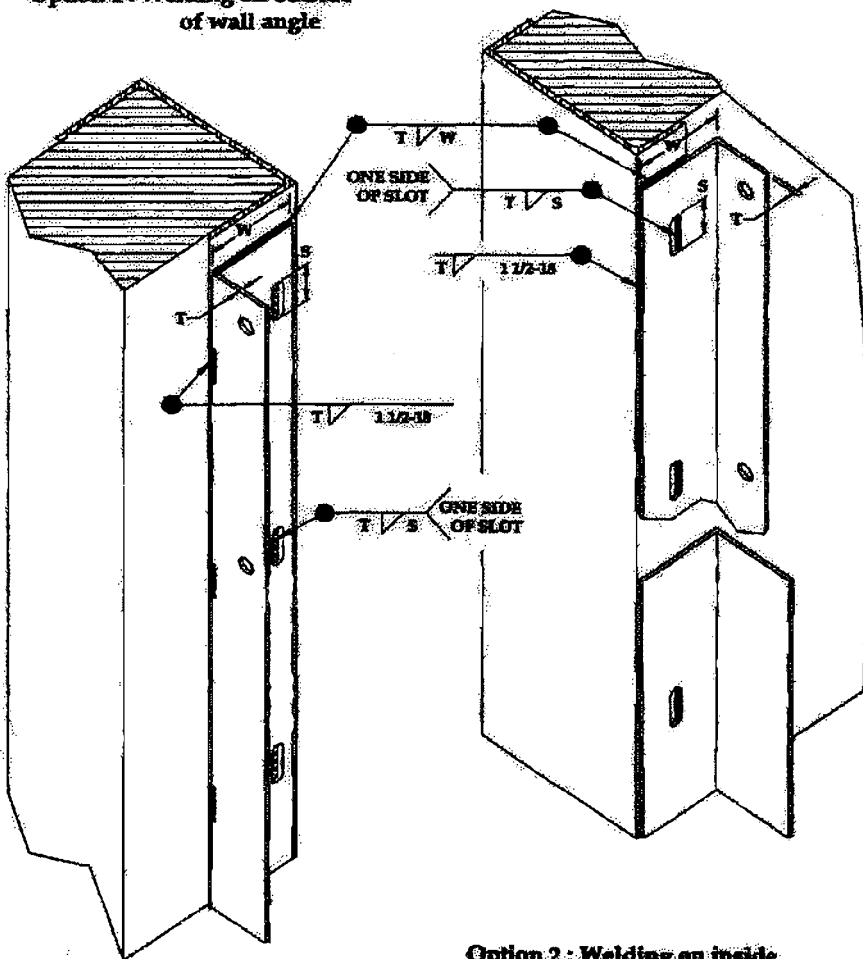

Use minimum 60XX electrodes. All welding is to be done "vertical up" (i.e. starting from the base of an individual weld and welding upwards) in accordance with A.S.T.M. procedures. Use fillet welds based on the information provided and in accordance with the local building authority.

Option 2: Welding on inside of wall angle

**FIGURE #11**



## Step 3 : Attaching Curtain to Barrel Assembly

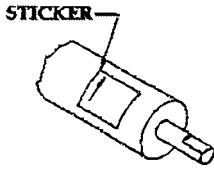

**FIGURE #12**

Lay out the curtain and barrel assembly in front of the opening. Note the green sticker located on the end of the barrel (see Figure #12). This sticker will indicate the right hand end, the direction the curtain uncoils to close the grille, and the spring turns required to balance the grille.

Orient the barrel with its right hand end on the right side of the opening. Center the top slat of the curtain with the barrel assembly and connect it to the barrel rings as shown in Figure #13. If rings are not provided, attach the top slat to bare pipe at weld nut locations **NOTE:** It is important that the bolts be tight - slats may distort some when tightening).

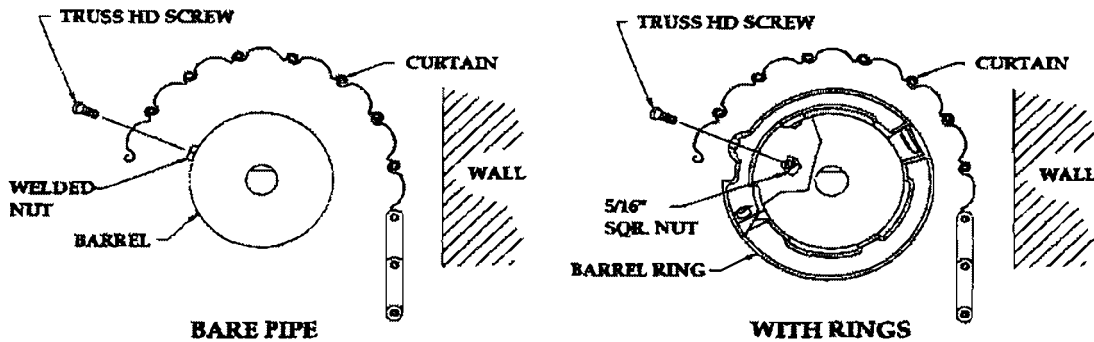
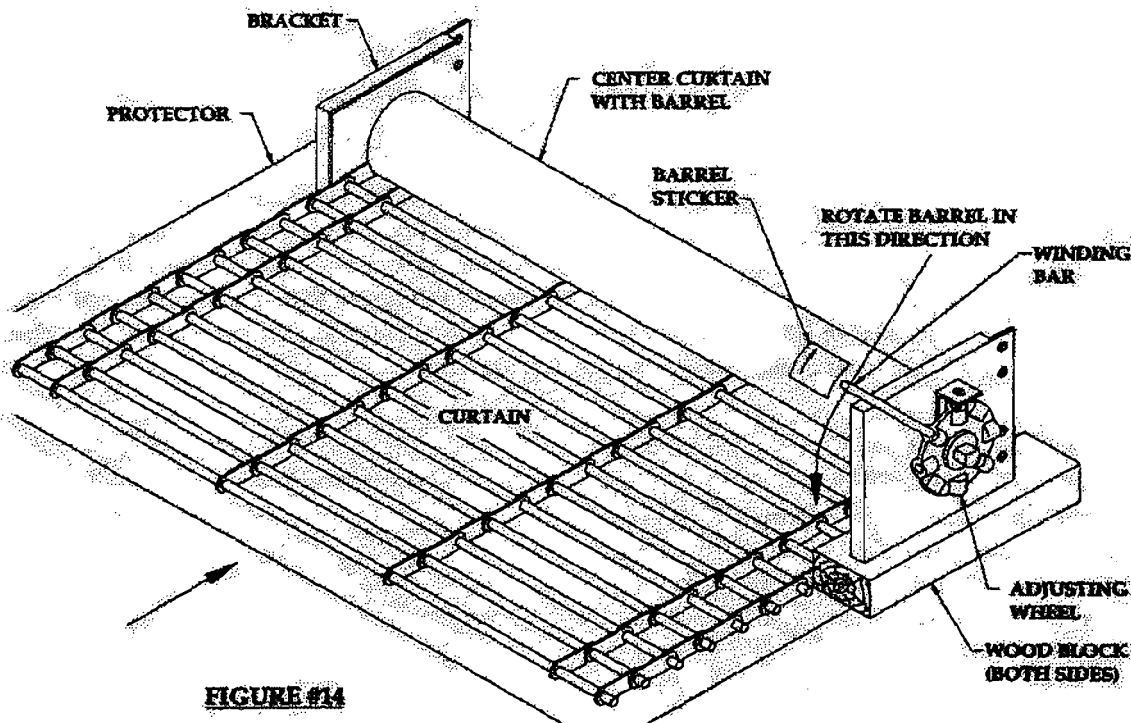

**FIGURE #13**

**IMPORTANT! LONGER BOLTS THAN PROVIDED MUST NOT BE USED, AS THEY MAY INTERFERE WITH THE INTERNAL PARTS OF THE BARREL.**

**⚠ CAUTION - ALL PARTS (EXCEPT KEYS) ARE DESIGNED FOR A SLIP-FIT. FORCING PARTS TOGETHER CAN CAUSE DAMAGE RESULTING IN MALFUNCTION OF DOOR.**

For smaller grilles (without inside adjusting), slide the operating and adjusting brackets onto the barrel shaft extensions and place the brackets on wood blocks as shown in Figure 14. Install the adjusting wheel onto the barrel shaft extension (with the flat) as shown in Figure #16. Apply tension to roll the curtain onto the pipe.



**FIGURE #14**

For larger grilles, see "Optional Method of Attaching Curtain to Barrel" on page 12.

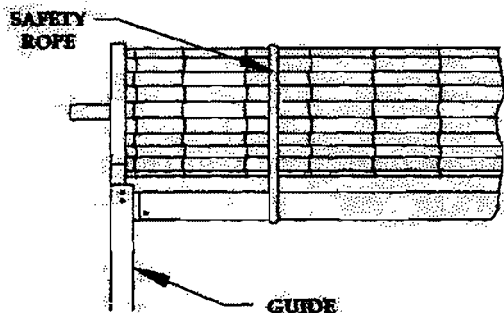
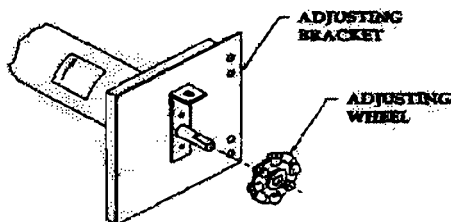

**FIGURE #15**

**NOTE: TAKE PRECAUTIONS TO PREVENT THE GRILLE CURTAIN FROM BEING DAMAGED WHEN SLIDING ON THE FLOOR.**

Tie a rope (or two depending on size-about every 8 ft.) around the coil to keep the grille curtain from uncoiling.

**NOTE: GENERALLY THE SPRINGS ARE CLOSER TO THE ADJUSTER SIDE MAKING THE COIL ASSEMBLY HEAVIER AT THAT END.**

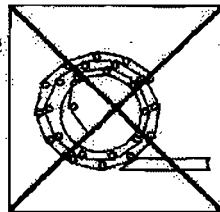

**FIGURE #16**

# Step 4 : Attaching Brackets to Wall Angles

Face Mounted Grille or Grille Mounted Between Jambs w/Extra Angle

Determine the best method of lifting the curtain coil and brackets to prevent damage to the curtain during installation. Refer to optional suggested methods below.



**⚠ WARNING - BRACKET AND CURTAIN ASSEMBLY ON LARGER GRILLES, PARTICULARLY WITH AN OPERATOR, CAN BE EXTREMELY HEAVY. PERSONS WITH BACK PROBLEMS OR OTHER PHYSICAL CONDITIONS WHICH MAY LIMIT THEM FROM LIFTING HEAVY OBJECTS SHOULD NOT PERFORM THE NEXT STEP.**

Refer to the following table to verify that the lifting capacity of the hoist (or fork truck) exceeds the weights given for the barrel and curtain assemblies:

Formula	Factor	Grille	Barrel
WxHx	1.1	Aluminum,Hollow,G1/G6	0.52 x Curtain Wt
WxHx	1.6	Stainless Steel,Hollow,G1/G6	0.52 x Curtain Wt
WxHx	1.9	Aluminum,Solid,G1/G6	0.52 x Curtain Wt
WxHx	2.5	Stainless Steel,Solid,G1/G6	0.52 x Curtain Wt
WxHx	1.7	Aluminum,Hollow,G7	0.52 x Curtain Wt
WxHx	2.6	Stainless Steel,Hollow,G7	0.52 x Curtain Wt
WxHx	2.5	Aluminum,Solid,G7	0.52 x Curtain Wt
WxHx	3.5	Stainless Steel,Solid,G7	0.52 x Curtain Wt
WxHx	0.5	Lexan Panels	

where W=width (feet), H=height (feet),Hollow is Hollow Rods, Solid is Solid Steel or Stainless Steel Rods,G6 is the standard curtain pattern, G1 is a brick pattern, G7 is the small 2x2 pattern

(ex: for an 8x8 aluminum grille, Curtain Wt =  $8 \times 10 \times 1.1 = 88$ ; Barrel =  $0.52 \times 88 = 45.7$ )

Lift the curtain assembly, brackets and barrel to the bracket mounting holes provided in the wall angle (FIG. 17).

FIGURE #17

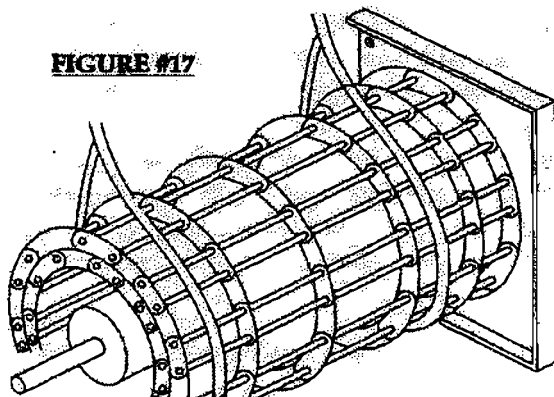
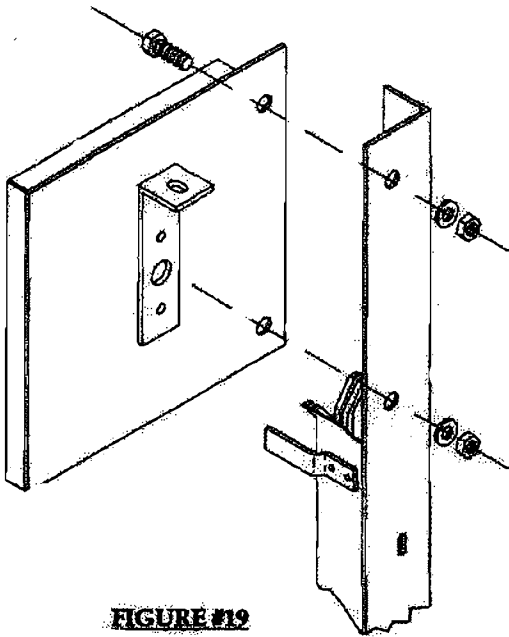

FIGURE #18

Make sure the bracket is positioned inside the Grille guide wall mounting angle (FIG 18).

Bolt the bracket and guides together as shown in Figure #19.



**FIGURE #19**

**HINT:** It is generally easier to insert the bottom bracket hole first, but do not tighten the bolt yet. As the coil is lifted higher, the brackets will pivot on this bolt for easily locating the top bracket bolts. Now tighten all bracket bolts.

**IMPORTANT!** THE BOLT HEADS MUST BE ON THE INSIDE (THREADED SECTION OUT) TO PREVENT INTERFERENCE WITH THE OPERATION OF THE COIL.

**⚠ WARNING - DO NOT REMOVE HOIST SLING UNTIL ALL BRACKET BOLTS ARE INSTALLED AND SECURE, OTHERWISE CURTAIN COIL COULD FALL STRIKING SOMEONE AND CAUSING SEVERE INJURY OR DEATH.**

**⚠ WARNING - DO NOT LET THE CURTAIN ROTATE IN FREE FALL. NO TENSION HAS YET BEEN APPLIED TO THE SPRINGS. FREE FALLING CURTAIN COULD STRIKE SOMEONE CAUSING SEVERE INJURY OR DEATH.**

Loosen the safety rope(s) to let the curtain uncoil until the bottom bar is a few inches below the top of the guides. Block the curtain in place to prevent it from dropping. Attach the front stop bars to the top of each guide.

#### 4b. Between Jambs Grille:

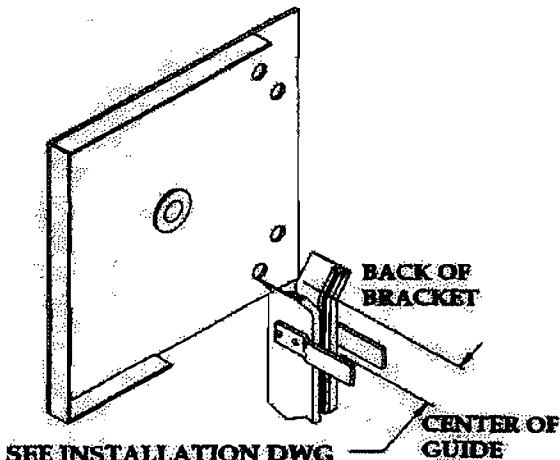

**FIGURE #20**

The brackets for between jambs mounted grilles often do not attach to the guide wall angle. Rather, they bolt directly to the wall (or square tubes). Since no holes are provided to direct the installer where to position the brackets on the wall (or tubes if tubes not supplied by factory), it is extremely important to place the brackets in the correct location.

**IMPORTANT!** THE POSITIONING OF THE BRACKETS ON THE WALL (OR TUBES) IS EXTREMELY IMPORTANT TO THE PERFORMANCE OF THE GRILLE. INCORRECT POSITION WILL RESULT IN EXCESSIVE DRAG AND POOR OPERATION OF THE GRILLE.

Refer to the installation drawing for the correct distance from the front of the grille guides to the back edge of the brackets (reference Fig 20). Hold the brackets in this position with the bottom edge of the bracket resting on the top of the guides. Scribe the location of the bracket mounting holes on the wall (or tubes). Drill the wall (or tubes) for the appropriate fasteners provided, and proceed to fasten the brackets. Check the brackets for level and plumb.

**IMPORTANT! IF WALLS ARE NOT PARALLEL, BRACKETS MUST BE SHIMMED TO CORRECT FOR THIS CONDITION. FAILURE TO DO THIS MAY RESULT IN MALFUNCTION OF GRILLE.**

Lift the curtain and barrel in place by dropping the barrel shafts into the holders in the brackets.

**⚠ WARNING - DO NOT LET THE CURTAIN ROTATE IN FREE FALL. NO TENSION HAS YET BEEN APPLIED TO THE SPRINGS. FREE FALLING CURTAIN COULD STRIKE SOMEONE CAUSING SEVERE INJURY OR DEATH.**

Carefully untie the rope(s) securing the coil. While restraining the coil from turning freely, feed the bottom bar into the top of the guides allowing the curtain to advance approximately 6" to 12". Block the bottom bar so it cannot travel beyond this point. Proceed to install the front bottom bar stops to the top of both guides.

**Optional Method of Attaching Curtain to Barrel:**

For some larger grilles, the combined weight of the coil and barrel may be too heavy to lift into place as one item as treated above. The optional method below describes how to lift each one separately.

Attach the operating bracket to the guides as described previously. Slide the adjusting bracket onto the barrel's tension shaft extension (with the flat) and lift the barrel assembly and adjusting bracket into place with a sling. Feed the operating shaft through the operating bracket already attached, and proceed to attach the adjusting bracket to the guides.

**HINT:** The tensioning end of the barrel contains most of the springs and is generally the heavier end, so sling the barrel accordingly to best balance the load.

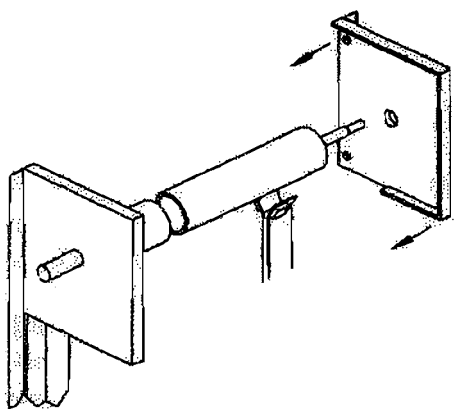

**FIGURE #21**

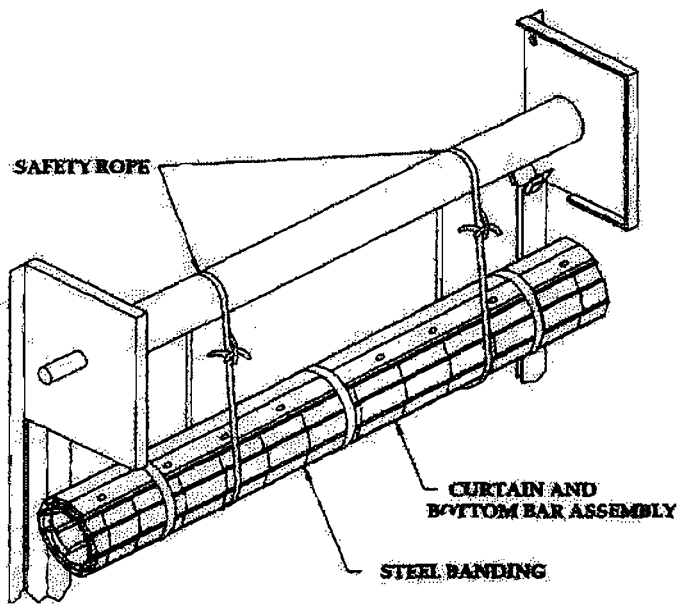

**FIGURE #22**

Choose two equal lengths of rope of adequate strength to support the coil's weight. Tie a large loop in these ropes around each end of the barrel so as to cradle the coil (see Fig #22). The coil and barrel should be separated by a minimum of 18" and the coil should be rolled to have the top attachment slats exposed.

Begin to rotate the barrel in the direction to raise the curtain. The rope loops will consequently uncoil the curtain. When sufficient curtain has been unrolled, attach the top slat to the rings (or bare pipe) as described earlier. With the top

slat attached, continue to completely unroll the curtain in a similar fashion.

**HINT:** Using the AW to wind the coil around the barrel may prove easier than manually turning the barrel.

**⚠ WARNING: DO NOT LET THE CURTAIN ROTATE IN FREE-FALL. NO TENSION HAS BEEN APPLIED TO THE SPRING. FREE FALLING CURTAIN COULD STRIKE SOMEONE CAUSING SEVERE INJURY OR DEATH.**

Carefully untie the rope(s) securing the coil. While restraining the coil from turning freely, feed the bottom bar into the top of the guides allowing the curtain to advance approximately 6" to 12". Block the bottom bar so it cannot travel beyond this point. Proceed to attach the front bottom bar stops to the top of both guides.

# Step 5 : Applying Tension

## Outside Adjusting Wheel:

The amount of initial revolutions (IR's) as indicated on the installation drawing and on the barrel "rev tag" is the THEORETICAL STARTING POINT for the required spring tension. In most cases this figure is correct, but due to variations in steel, springs, friction, etc., slight adjustments may be required.

**⚠ CAUTION - ALWAYS WIND TENSION WHEN THE GRILLE IS IN THE UP POSITION. THE SPRINGS ARE UNDER THE LEAST AMOUNT OF TENSION AT THIS POINT.**

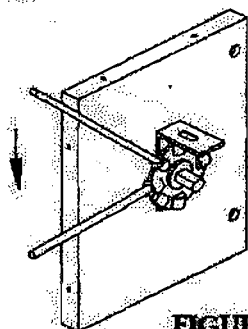

**FIGURE #23**

By hand, rotate the adjusting wheel (AW) slightly in both directions to determine the neutral point of the tension shaft. Mark the hole on the AW which is nearest to the retaining lug on the tension bracket. Using approved winding bar (see tool list in front of manual), insert the two winding rods securely into the holes in the AW as shown in Figure #23.

**NOTE: TENSION IS APPLIED IN THE DIRECTION AS THE GRILLE WOULD TURN AS IT COILS UPWARD (OPPOSITE THE DIRECTION OF THE ARROW ON THE "REV TAG").**

**⚠ WARNING - WINDING BAR MUST FIT SNUGLY INTO HOLES IN ADJUSTING WHEEL. DO NOT USE LOOSE FITTING BARS OR SCREWDRIVERS WHICH COULD SLIP OUT AND CAUSE SEVERE INJURY OR DEATH. STAND TO ONE SIDE - NEVER WIND THE SPRING DIRECTLY IN FRONT OF YOU.**

Apply the initial revolutions (IR's) marked on the rev tag and installation drawing counting from the mark on the AW made earlier. The IR's are the required number of turns (of the spring) to hold the curtain in the open position. **HINT:** If installation permits, use wall above brackets as brace for winding rod for a safe, hands-free procedure of installing the AW pin (Fig #24).

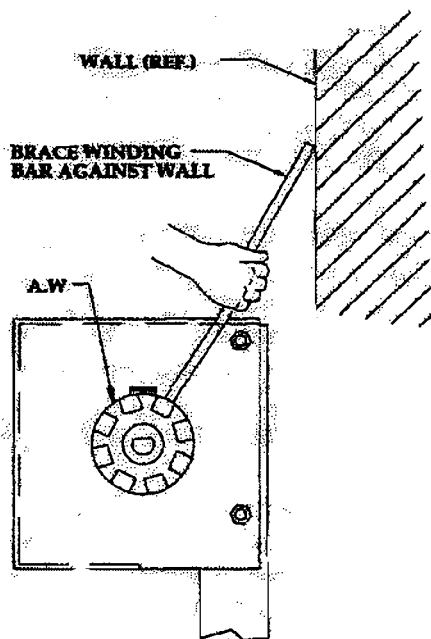
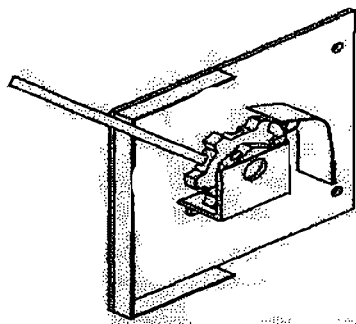

**FIGURE #24**

**⚠ WARNING: EXERCISE EXTREME CAUTION. DO NOT RELEASE THE ADJUSTING WHEEL. CONTACT WITH RAPIDLY ROTATING WHEEL OR EXPELLED WINDING ROD CAN CAUSE SEVERE INJURY OR DEATH.**

While holding the winding bar firmly in one hand, insert the AW pin with the other hand through the lug in the bracket and into the hole in the AW to lock the AW at the desired number of revs. Remove winding rods. (See Figure #24).

**IMPORTANT! APPLY ONLY ENOUGH TENSION TO HOLD THE GRILLE IN THE UP POSITION AGAINST THE BOTTOM BAR STOPS. THIS IS THE OPTIMUM SETTING. TOO MUCH TENSION WILL PREVENT THE GRILLE FROM COMPLETELY CLOSING.**



**FIGURE #25**

#### Inside AW:

See Figure #25 for instructions in the winding of an inside AW, should the grille require one. The curtain must be unrolled to access the AW. Using  $\frac{1}{2}$ " square winding bars, apply the total revs indicated on the rev tag. Test and adjust as required for proper balance.

**⚠ WARNING: DO NOT LET THE CURTAIN ROTATE IN FREE-FALL. NO TENSION HAS BEEN APPLIED TO THE SPRING. FREE FALLING CURTAIN COULD STRIKE SOMEONE CAUSING SEVERE INJURY OR DEATH.**

**⚠ WARNING: THE INSIDE AW CAN ONLY BE ACCESSED WITH THE CURTAIN DOWN. EXERCISE EXTREME CAUTION AS TOTAL TENSION MUST BE APPLIED. DO NOT RELEASE THE ADJUSTING WHEEL CONTACT WITH RAPIDLY ROTATING WHEEL OR EXPELLED WINDING ROD CAN CAUSE SEVERE INJURY OR DEATH.**

#### Compound AW (sprocket reduction):

See Appendix E, "Compound Tension Adjuster Assembly", for instructions to wind a compound AW. With the curtain up, wind the initial revs with  $\frac{3}{4}$ " winding bars by counting the large sprocket.

#### Inside Dead-Tension Adjuster (inside holder):

See Figure #26 for instructions to wind an inside dead-tension adjuster. The curtain is lowered in the guides but not bolted to the barrel. The tension shaft is bolted to the holder on the bracket. The curtain, crank, hoist or motor is used to turn the pipe in the direction shown to wind the total revs. Then, fasten the curtain to the barrel.

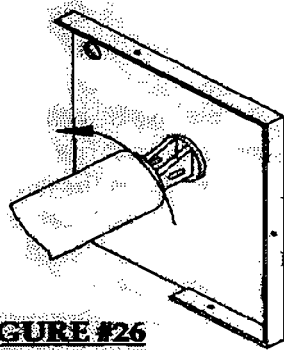

**FIGURE #26**



## STEP 6 : Testing Grille Balance

With the adjusting wheel locked, operate the grille through several cycles to check grille balance if possible. If the grille does not balance properly and requires further spring adjustment, repeat the procedure for "Applying Tension" to add or remove spring tension. Ideally, the grille should have sufficient spring tension to just allow the grille to stay up in the open position and no more.

**IMPORTANT! GRILLES PROVIDED WITH EMERGENCY EGRESS DEVICE ARE DESIGNED TO RAISE OFF THE FLOOR IN THE CLOSED POSITION.**

**IMPORTANT! INCREASING THE INITIAL TENSION WILL REDUCE THE LIFT EFFORT BUT CAN PREVENT GRILLE FROM COMPLETELY CLOSING.**

### Methods Of Operation Of Rolling Grilles

- **Manually Operated Grille (Push-up):**  
No operator of any kind is required. The grille is opened and closed manually by pushing up and down on the bottom bar (taller grilles may require a rope or hook to reach the bottom bar in the open position).
- **Chain Hoist:** Install the hoist as shown in Figure #27.
- **Awning Crank Operate:** Install the awning crank as shown in Figure #28.
- **Motor Operated:**  
**Bracket Mounted:** Install the power unit support and operator as shown in Figure #29.

**IMPORTANT! ON GRILLES SUPPLIED WITHOUT HOOD, IT IS NECESSARY TO BRACE THE OPERATING BRACKET TO THE WALL. THE ABSENCE OF A HOOD OR ANY BRACING WILL RESULT IN EXCESS SHAKING DURING OPERATION.**

**⚠ WARNING - MECHANISM AND GEARS MOVE FREELY AND QUICKLY. TO AVOID SEVERE INJURY OR DEATH, KEEP HANDS, ARMS AND CLOTHING FREE OF MOVING MECHANISMS AND MESHING GEARS.**

### Chain Hoist Operated Grille (RH Shown, LH Opposite)

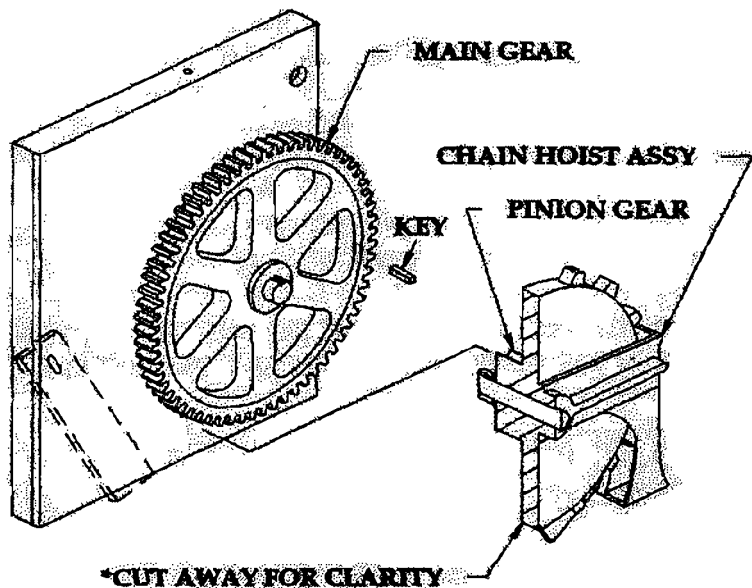

**FIGURE #27**

### Awning Crank Operated Grille (RH Shown, LH Opposite)

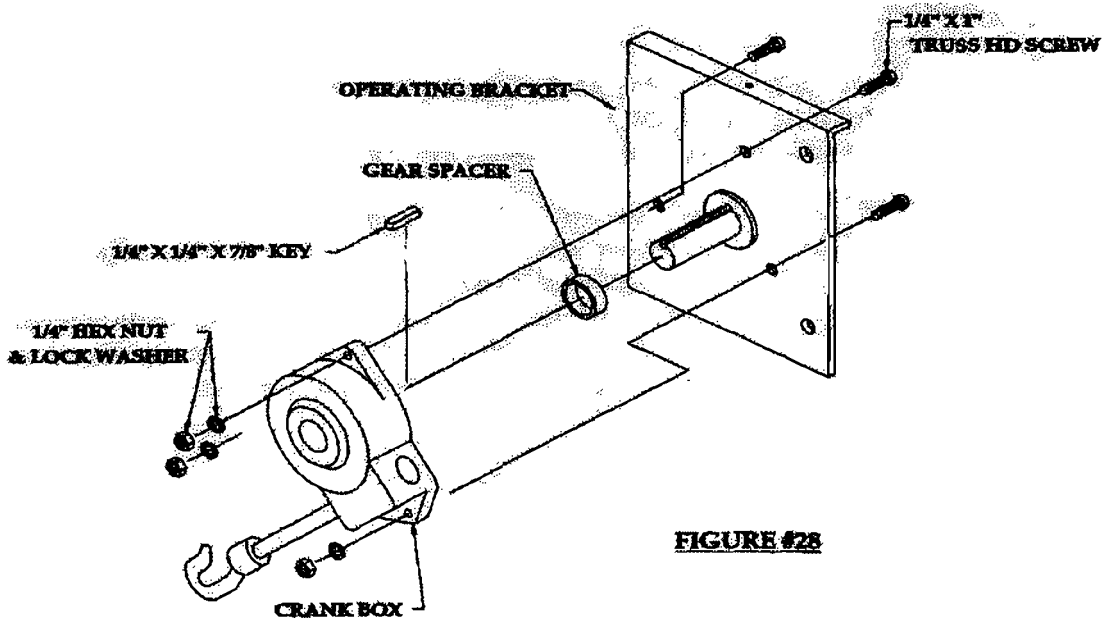

**FIGURE #28**

# Bracket Mounted Motor Operated Grille (RH Shown, LH Opposite)

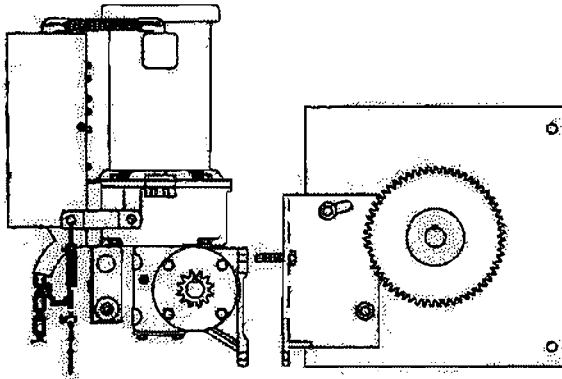

**STEP 1: LIFT OPERATOR INTO POSITION.**

**STEP 2: ATTACH OPERATOR WITH 3/8" BOLTS.**

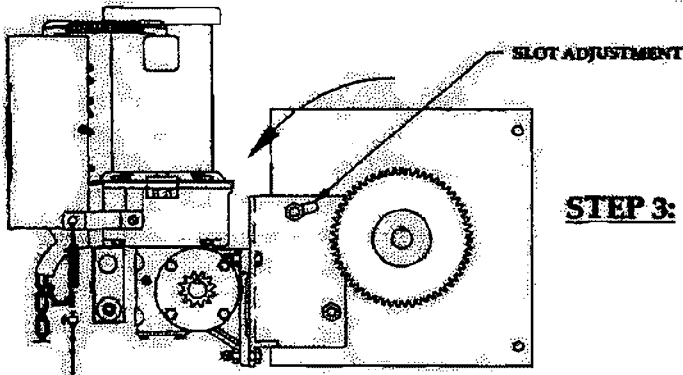
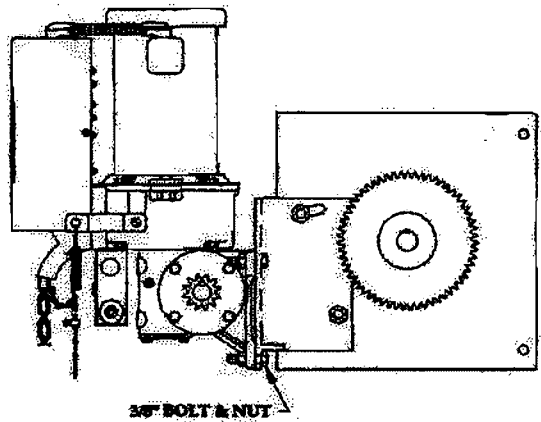

**STEP 3: TENSION CHAIN WITH SLOT ADJUSTMENT**

**FIGURE #29**

**⚠ WARNING : GETTING HANDS CAUGHT IN SPROCKETS OR CHAIN CAN CAUSE SEVERE INJURY. A GUARD OR COVER MUST BE INSTALLED IF THESE COMPONENTS ARE WITHIN REACH. COVERS ARE AVAILABLE AS OPTIONS FROM THE FACTORY.**

# Step 7 : Installing Hoods & Hood Supports

## Hood (and Hood Support) Attachment:

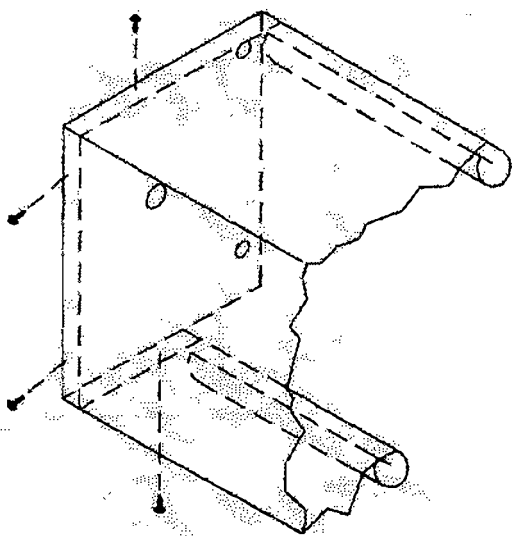

FIGURE #30

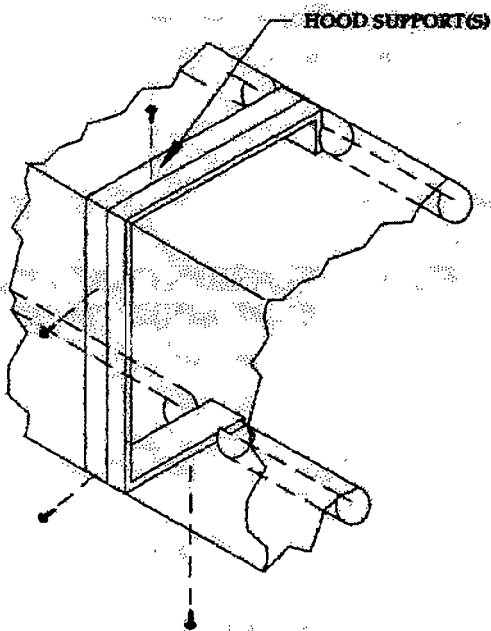

FIGURE #31

**HINT:** Lower the grille to offer the maximum clearance between the coil and the wall. Rest hood strap(s) on coil near its attachment location.

**⚠ WARNING - DISCONNECT POWER TO THE OPERATOR PRIOR TO WORKING NEAR OPERATOR END OF GRILLE WHEN ATTACHING HOOD. THIS WILL PREVENT SERIOUS INJURY DUE TO ANY UNEXPECTED ACTIVATION OF THE OPERATOR.**

When a two or more piece hood is furnished, fasten the hood support (sometimes called "hood strap") to the wall where the hood is spliced together (see Figure #30). It may be necessary to add structure on "open steel" type construction (not provided by manufacturer as standard).

Raise the hood carefully over the brackets so the ends of the hood are approximately  $3/16$ " from the outside edge of the brackets. Slide the top tight against the wall. Fasten the hood to the brackets (and supports) with self-tapping screws. If housings are required, do not tighten screws at this time, as housing must slip under hood. **HINT:** Use a center punch to locate position of screws in brackets before attachment.

**IMPORTANT! NEVER OMIT THE USE OF CENTER HOLE PROVIDED IN BRACKET WHEN ATTACHING HOOD. THIS REDUCES FLEXING OF BRACKETS WHEN OPERATOR IS USED.**

Remove any protective film on stainless steel or aluminum hoods and apply the Wayne-Dalton label to the center of the hood.

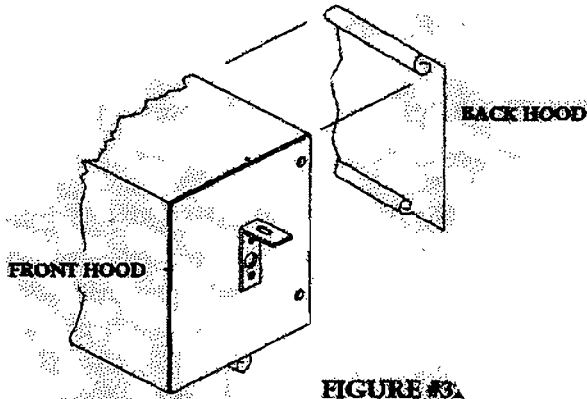

**FIGURE #3.**

If a back hood is provided, attach it as shown in Figure #32 with self-tapping screws. Line up the edge of the back hood with the edge of the front hood before tightening screws.

Remove any protective film on stainless steel or aluminum hoods.

## **STEP 8 : Miscellaneous Final Checklist**

**Apply all warning labels in the appropriate locations before leaving the installation site.**

**Check the area for any extra parts, and be sure these were not omitted in the installation process.**

**Have the customer or his representative sign off on the installation, and exchange all documentation and keys to locks at this time. Be sure the customer receives a copy of this manual and of the installation drawing.**

**If the customer is unfamiliar with the product, demonstrate the operation of the grille and any optional equipment before leaving the job site.**

**Don't leave a mess. Clean up the area and make sure the area is secure if you're the last one to leave.**

**Be sure to report (in writing) to the factory any complaints or recommendations the customer may register at the completion of the installation that may have a bearing on future designs.**

# Appendix A : Optional Components

The following are some examples of common options and adjustments for grilles:

## CYLINDER LOCKS-JAMB MOUNTED

Slide bolts are provided as a standard feature on manually operated grilles. Below is a typical installation showing a jamb lock.

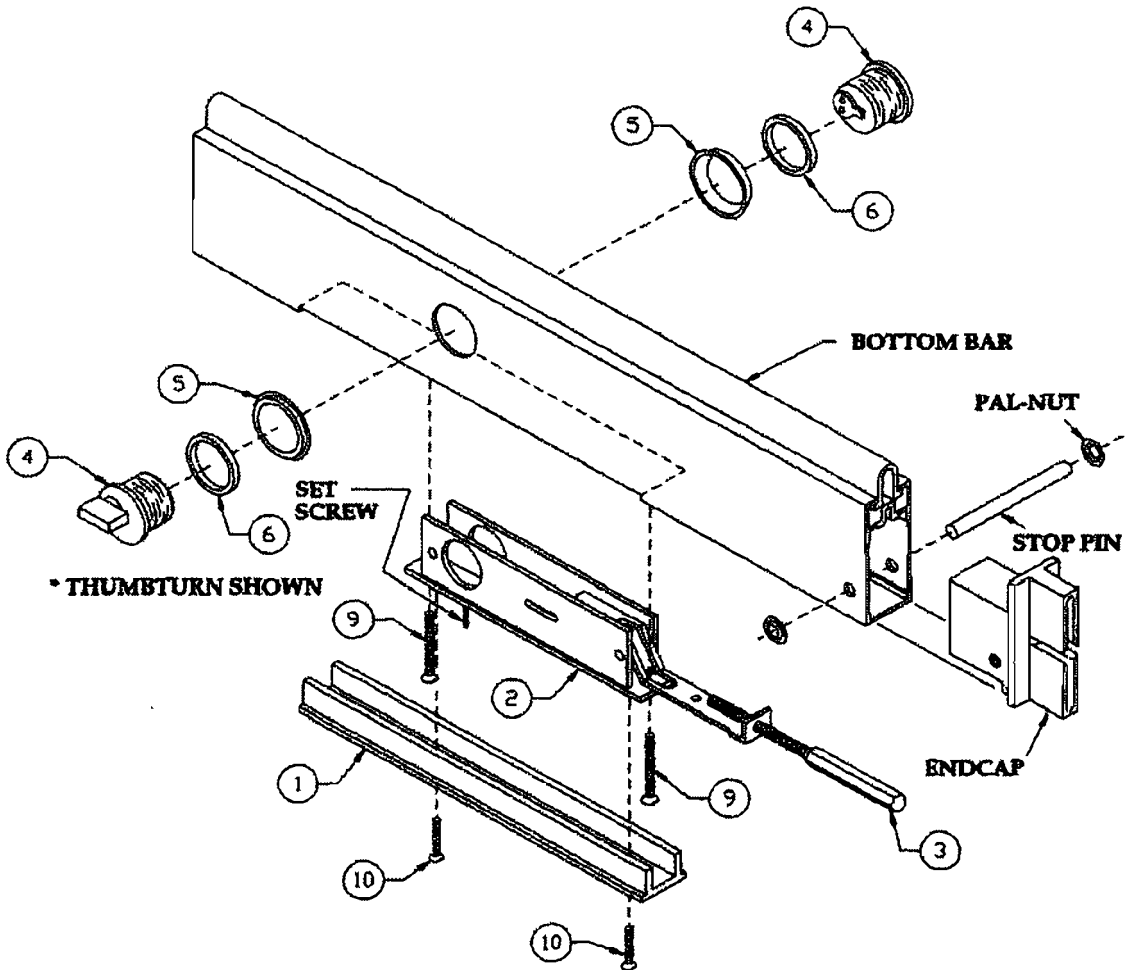

10	4	SCREW : #8-32 x 1" FLAT HEAD
9	4	SCREW : #10-24 x 2" FLAT HEAD
8	2	LABEL : UNLOCK - LOCK
7	2	LABEL : LOCK - UNLOCK
6	4	TRIM RING : 1/4"
5	4	ADJUSTING RING : 1/4" THICK
4	4	CYLINDER : LORI #4100-03
3	2	LOCK ROD END
2	2	LOCK : FLUSH, 1-1/8", #41-444-03
1	2	COVER PLATE : LOCK, D-1240 X 10" LONG
ITEM	NO.	DESCRIPTION

## CYLINDER LOCKS-CENTER MOUNTED

Adjustment may be made as follows:

The throw of the center lock is preset at the factory and should not require any field adjustment. If adjustment is necessary and the grille is not yet installed or the curtain/bottom bar can be removed from the guides, the throw of the lock rods may be extended by rotating the end of the lock rod assembly. With the lock handle in the locked position, rotate the end of the lock rod projecting from the endcap counter-clockwise to extend the throw.

If the grille is installed and the bottom bar cannot be removed from the guides, the lock rod can be adjusted as follows:

1. Access to the center lock assembly is gained through a hole in the coil side of the bottom bar. This requires removing the thumb turn and cover plate. The thumb turn is threaded into the lock body and secured by a set screw on the underside of the bottom bar. Loosen the set screw and unscrew the thumb turn from the lock body. Remove the screws or rivets securing the cover plate and remove the cover plate.
2. To adjust the throw of the lock rods, rotate the lock rod assembly. By rotating the double hex nuts on the end of the assembly clockwise, it will extend the length of throw.
3. Reassemble the bottom bar by reversing the steps listed above.

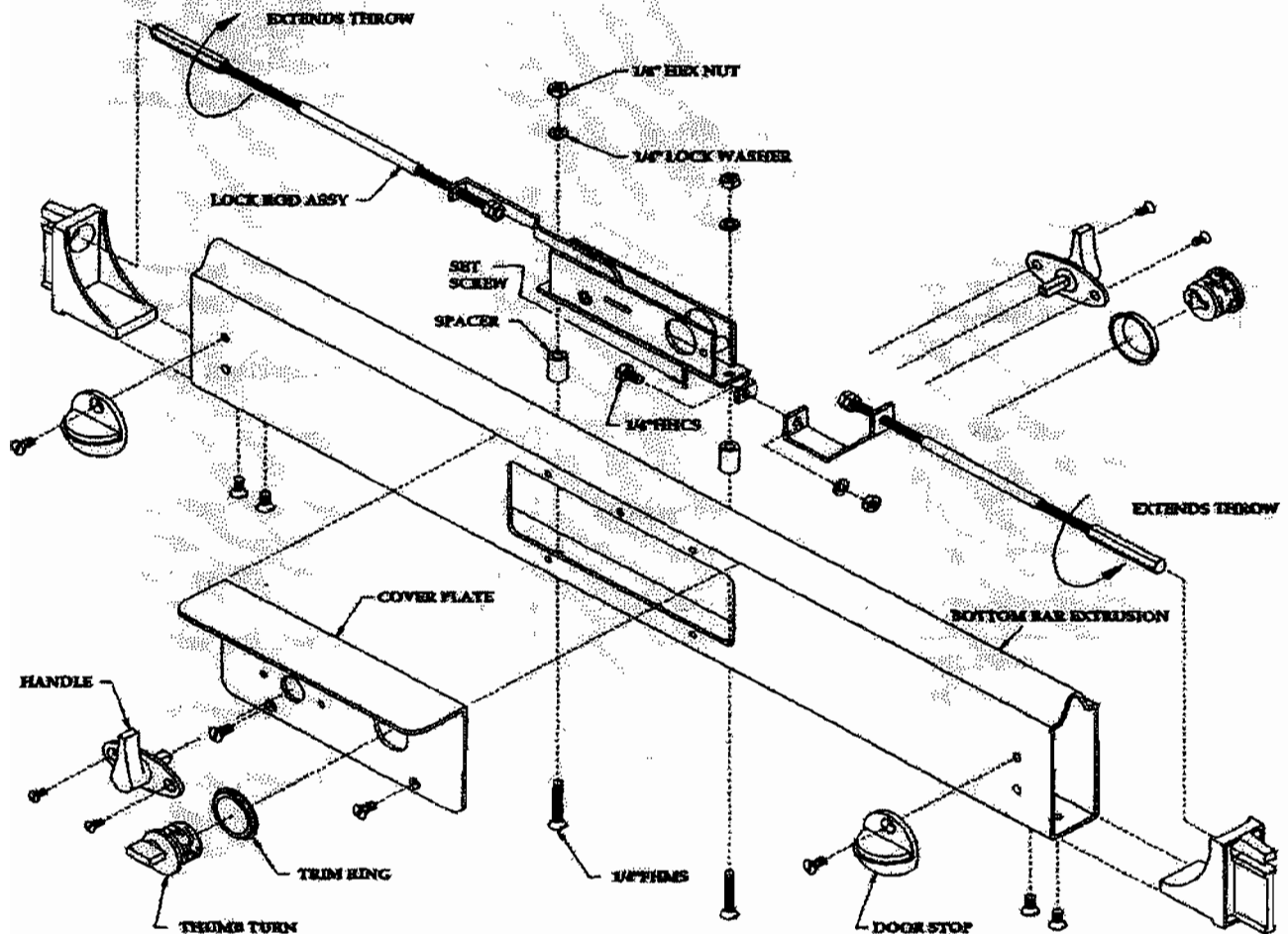

## ELECTRICAL OR PNEUMATIC SAFETY EDGE

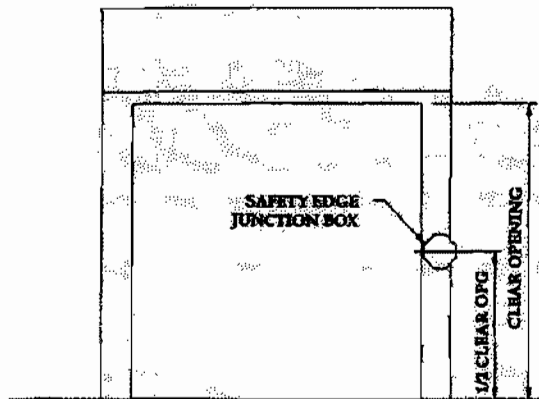

Mount the junction box to the outside of the guide angles using one of the assembly bolts.

**NOTE :** THE JUNCTION BOX NEEDS TO BE AT A HEIGHT OF  $\frac{1}{4}$  THE OPENING OR DOOR TRAVEL HEIGHT TO ENSURE THE COILED WIRE OR HOSE WILL REACH THE BOTTOM BAR WITH THE DOOR IN THE FULLY OPEN OR FULLY CLOSED POSITION.

See the wiring diagram included with the motor operator for wiring of the electric or pneumatic safety edge.

## PNEUMATIC SAFETY EDGE (with air switch mounted on bottom bar):

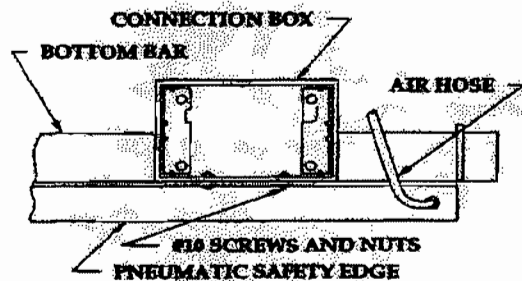

**FIG. 1**

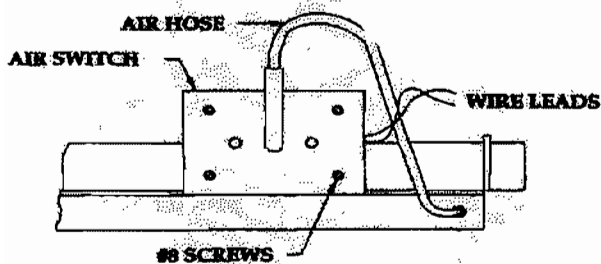

**FIG. 2**

On grilles with pneumatic safety edges with cable take-up reels (ie, air switch mounted on the bottom bar), it is necessary to remove the air switch prior to installation.

### REMOVAL:

1. Remove the (2) #10 screws and nuts securing the air switch connection box to the bottom bar.
2. Remove the connection box.

### INSTALLATION:

1. Reverse the above procedures.
2. Run wire leads from cable reel into connection box and make connection to air switch.
3. Install air switch lid with the (4) #8 screws provided.
4. Attach air hose to air switch lid on brass fitting.
5. Air switch sensitivity may be adjusted as desired by turning the adjustment screw on the center of the switch.



## ELETRICAL INTERLOCKS

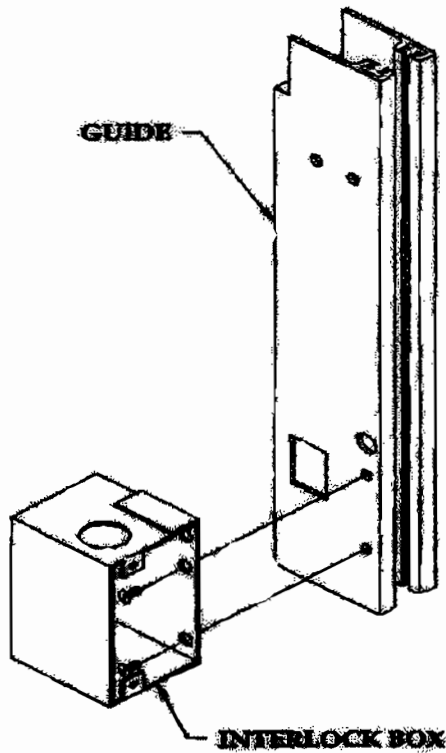

Slide the tab on the interlock switch into the large slot in the guide. Line up the three holes of the interlock box with the three holes in the guide. Secure the interlock box to the guide with the (2) two screws provided.



## Appendix C : Trouble Shooting

The chart below is a list of possible problems with the operation of the grille. The probable causes listed are the most common, and are not meant to include ALL possibilities. With the variety of the product and the field conditions, other factors may be involved.

TROUBLE	PROBABLE CAUSE	REMEDY
Grille raises hard, closes easily	Insufficient counterbalance	Increase spring tension (see Step 6)
Grille closes hard, raises easily	Too much counterbalance	Decrease spring tension (see Step 6)
Grille jumps up from floor (and does not have emergency egress)	Too much counterbalance	Decrease spring tension (see Step 6)
Cylinder locks do not engage	Out of adjustment	Adjust as required per Appendix A
Grille sticks when closing	Bent guide angle(s)	Inspect for bent or kinked guides. Straighten guides and check wool pile for interference
Grille jams in guides, won't coil	Links frozen, unable to pivot	Lubricate frozen joint or replace defective link
Grille squeaks when operating	Guides misaligned Dirty guides	Check alignment and distance between guides. Inspect and clean inside of guide. Do not lubricate with grease. Use WD-40 or silicone spray.
Grille is difficult to raise, will not stay open	Insufficient Counterbalance Broken spring or wrong hand springs	Increase spring tension. (see Step 6) Remove barrel and replace spring.
Motor runs, Grille does not operate	Curtain jammed Sprocket does not turn	Inspect and remove obstruction. Inspect for missing key. Inspect drive shaft for broken weld.

# Appendix D : Emergency Egress Device

## VERTICAL TOP OF BRACKET MOUNTED POWER UNIT

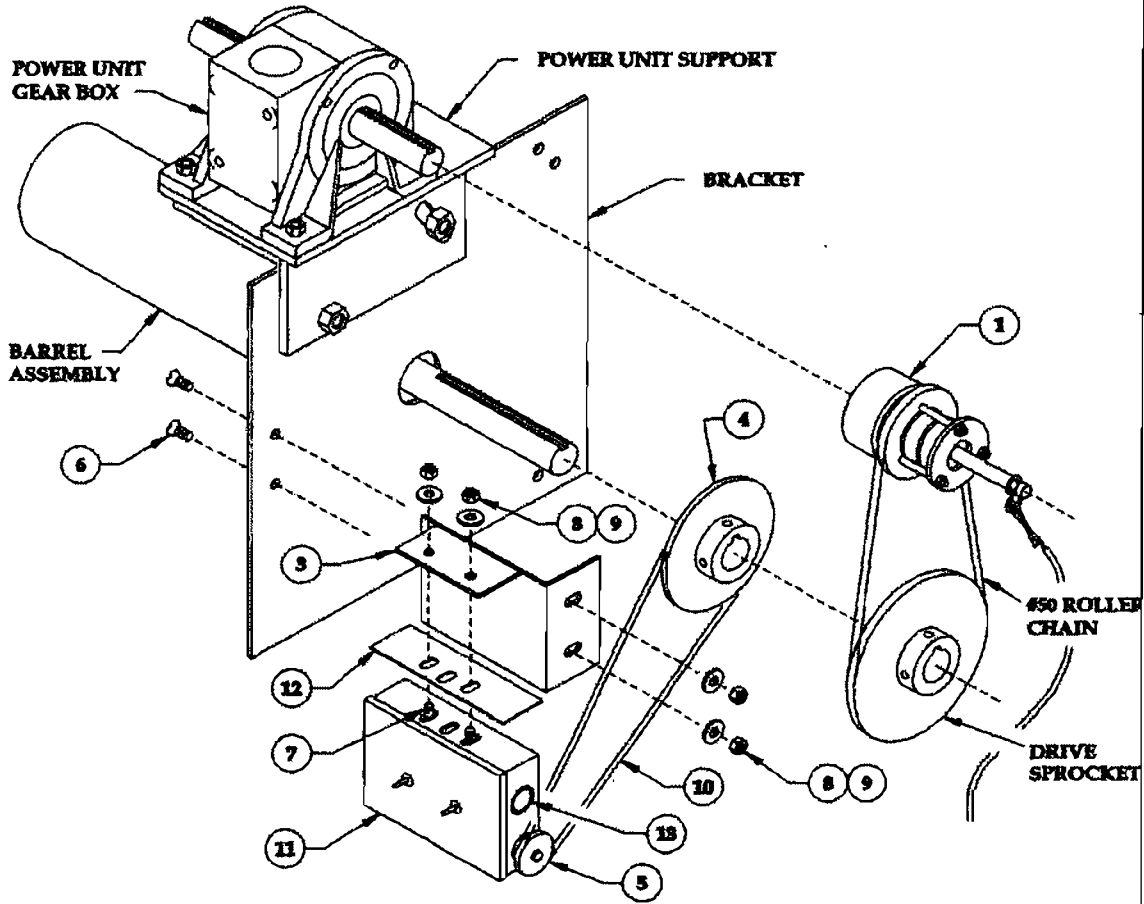

**NOTES :**

1. RIGHT HAND DOOR SHOWN.

2. DRIVE SHAFT EXTENSION TO BE INCREASED BY 2-1/2".

ITEM	QTY	DESCRIPTION
13	2	#11-X CAP PLUG
12	1	NEOPRENE GASKET
11	1	LIMIT SWITCH ASSEMBLY
10	1	ROLLER CHAIN : #41
9	4	5/16"-18 HEX NUT
8	4	5/16" FLAT WASHER
7	2	5/16"-18 X 1/2" HEX HEAD CS
6	2	5/16"-18 X 3/4" FLAT HEAD CS
5	1	SPROCKET : LIMIT SWITCH 41B9
4	1	SPROCKET : LIMIT SWITCH DRIVE 41B32
3	1	LIMIT SWITCH SUPPORT, RH
2	1	EMERGENCY EGRESS BOX (FLUSH MTD)
1	1	EMERGENCY EGRESS CLUTCH

## EMERGENCY EGRESS FOR GRILLES

# Appendix E : Compound Tension Adjuster Assembly

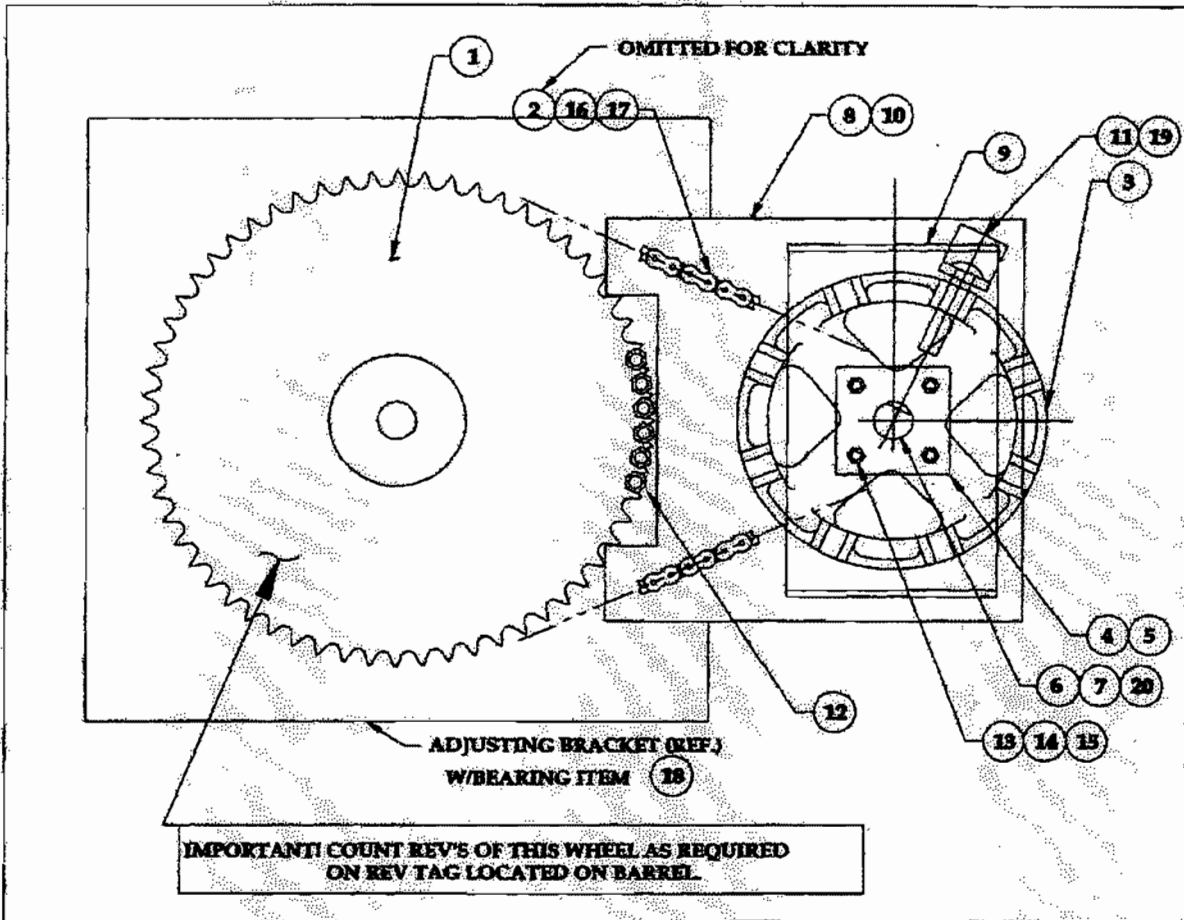

20	1	COTTER PIN : 1/4" X 1/4" STEEL
19	1	RIVET : 3/4" X 1/2"
18	1	OPERATOR BRACKET BEARING
17	AR	ROLLER CHAIN, SERIES AND LENGTH VARY
16	1	KEY : 3/8" X 3/8" X 1-1/4"
15	8	3/8"-16 HEX NUT
14	8	3/8" FLAT WASHER
13	8	3/8"-16 X 1-1/4" RHCS
12	6	TAP BOLT : 1/2"-13 X 2-1/2"
11	1	CLIP ANGLE : 1" X 1/4" X 2" LONG
10	1	TENSION HOLDER : 2" X 10" X 1/2" BAR
09	1	SHAFT SUPPORT PLATE
08	1	MOUNTING FLATE : 16" X 16" X 3/8" STEEL
07	2	SHAFT COLLAR : 1-1/2" ID
06	1	SHAFT : 5-1/2" X 1-1/2" DIA (C1045)
05	2	BEARING : 1-1/2" ID
04	2	BEARING RETAINER
03	1	ADJUSTER : AW745 1-1/2" BORE
02	1	SMALL SPROCKET, 13T, 1-1/2" BORE
01	1	LARGE SPROCKET (SIZE VARIES)
ITEM	QTY	DESCRIPTION

**COMPOUND TENSION ADJUSTER ASSEMBLY**

Use bolts (item 12) to lock large sprocket (item 1) into place after applying tension. The amount of initial turns is determined by the large sprocket.

**⚠ WARNING! THE BOLTS MUST BE IN PLACE BEFORE THE GRILLE IS OPERATED. THE ROLLER CHAIN WILL NOT HOLD THE WEIGHT OF THE GRILLE. FAILURE TO INSTALL ALL THE BOLTS COULD RESULT IN THE CHAIN BREAKING CAUSING THE GRILLE TO FALL AND COULD CAUSE SERIOUS INJURY OR DEATH.**