

MANUAL OPERATION

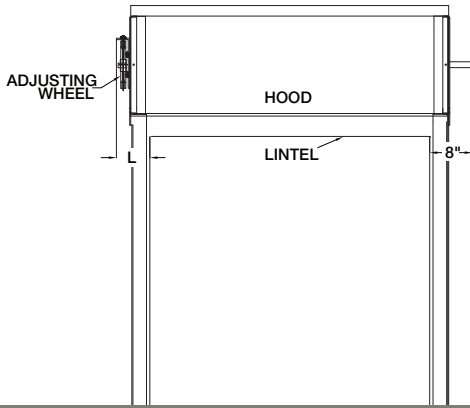

ELEVATION

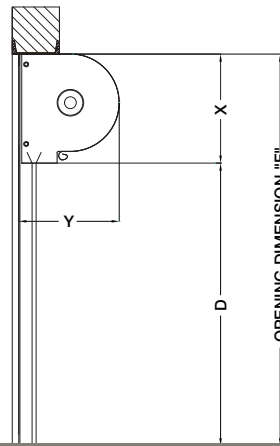

SECTION (BETWEEN JAMB)

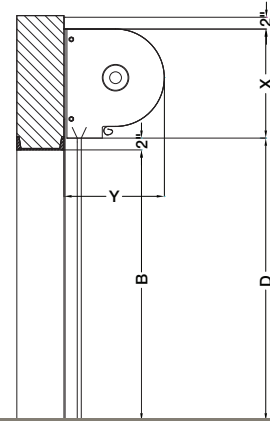

SECTION (FACE MOUNT)

BRACKET MOUNTED POWER UNIT

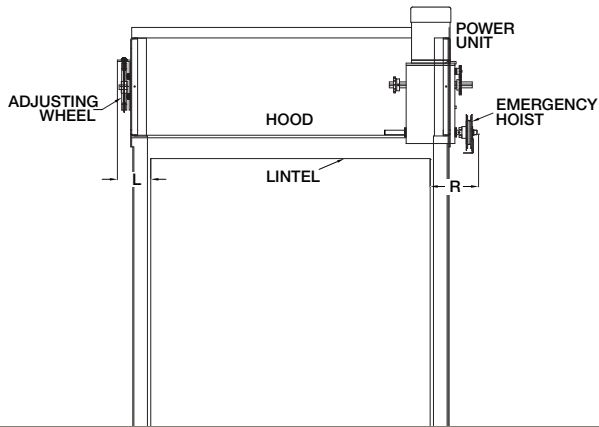

ELEVATION

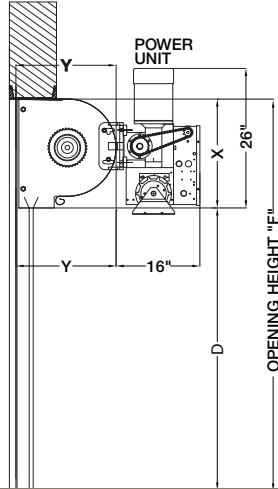

SECTION (BETWEEN JAMB)

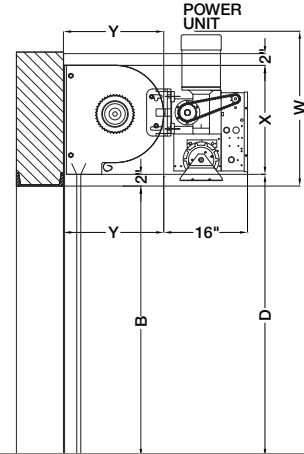

SECTION (FACE MOUNT)

CHAIN HOIST OPERATION

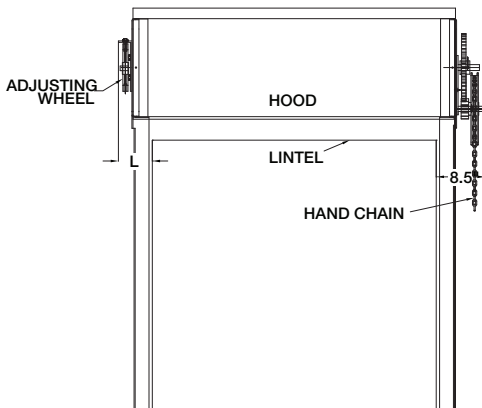

ELEVATION

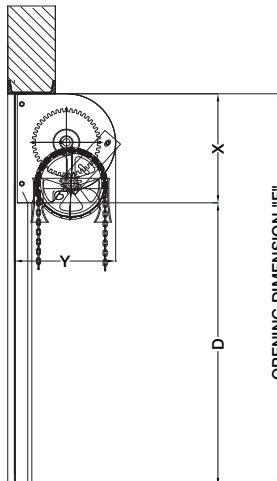

SECTION (BETWEEN JAMB)

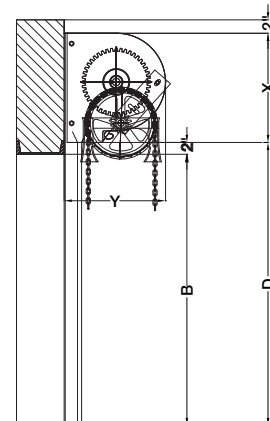

SECTION (FACE MOUNT)

WALL MOUNTED POWER UNIT

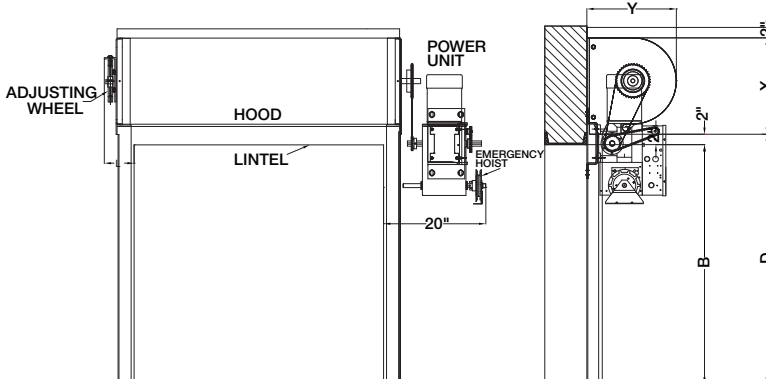

ELEVATION

SECTION (FACE MOUNT)

THRU-WALL MOUNTED POWER UNIT

Note: 20" sideroom required on opposite door side for power unit

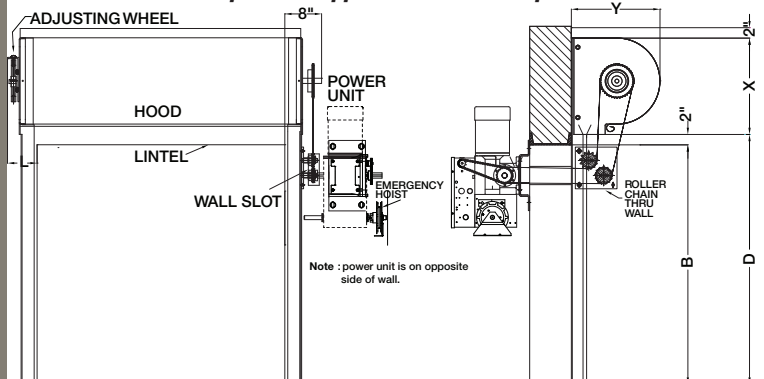

ELEVATION

SECTION (FACE MOUNT)

Note: power unit is on opposite side of wall.

Model 900 Face Mounted

Width A	HEIGHT B (OPENING HEIGHT)					
	TO 8'8"			8'-9" TO 12'0"		
	BRACKET SIZE	SIDE ROOM		BRACKET SIZE	SIDE ROOM	
	X & Y	R	L	X & Y	R	L
CHAIN HOIST OPERATED, MOTOR OPERATED						
TO 12'0"	14-1/2"	8"	6"	16-1/2"	8"	6"
CRANK OPERATED—CONSULT FACTORY						

NOTE: Dimensions are for general reference only and not for construction purposes.

Model 900 Between Jamb Mounted

Width A	HEIGHT B (OPENING HEIGHT)					
	TO 8'8"			8'-9" TO 12'0"		
	BRACKET SIZE	SIDE ROOM		BRACKET SIZE	SIDE ROOM	
	X & Y	R	L	X & Y	R	L
CHAIN HOIST OPERATED, MOTOR OPERATED						
TO 12'0"	14-1/2"	4-1/4"	4-1/4"	16-1/2"	4-1/4"	4-1/4"
CRANK OPERATED—CONSULT FACTORY						

NOTE: Dimensions are for general reference only and not for construction purposes.

ANGLE OR ROLLED GUIDES – FACE MOUNTED TO MASONRY

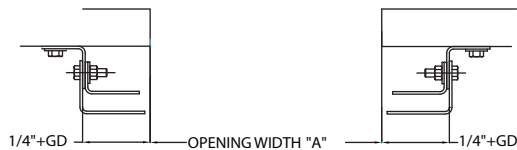

ANGLE OR ROLLED GUIDES – FACE MOUNTED TO STEEL

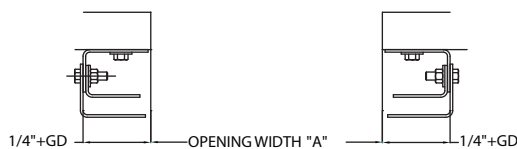

MODEL 926	
GD	WIDTH
2-5/16"	TO 12'0"

ANGLE GUIDES – MOUNTED BETWEEN JAMBS

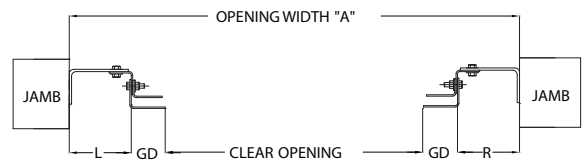

ROLLED GUIDES – MOUNTED BETWEEN JAMBS

