

## Models 8440, 464, 451, 452 And K-AL

ALUMINUM FULL VIEW

TORSION, STANDARD LIFT

COMMERCIAL

MH  
INSTALLATION INSTRUCTIONS AND OWNER'S MANUAL

Please call 1-866-569-3799 (Press Option 1) and follow the prompts to contact the appropriate customer service agent. They will be happy to handle any questions that you may have.

### Table Of Contents

<b>Pre-Installation</b>	<b>2</b>
Important Safety Instructions	2
Tools Required	2
Package Contents	2
Door Section Identification	3
Removing an Existing Door	4
Preparing the Opening	4
<b>Parts Breakdown</b>	<b>7</b>
<b>Installation</b>	<b>8</b>
<b>Optional Installation</b>	<b>21</b>
Inside Lock	21
Step Plate	21
Pull Down Rope	21
Exhaust Port	21
Chain Hoist	21
Pusher Springs	22
<b>Maintenance</b>	<b>23</b>
Cleaning Your Garage Door	23
Operation And Maintenance	23
<b>Warranty</b>	<b>24</b>

### **IMPORTANT NOTICES!**

Wayne Dalton highly recommends that you read and fully understand the Installation Instructions and Owner's Manual before you attempt this installation.

To avoid possible injury, read the enclosed instructions carefully before installing and operating the garage door. Pay close attention to all warnings and notes. After installation is complete, fasten this manual near garage door for easy reference.

The complete Installation Instructions and Owner's Manual are available at no charge from:

Wayne Dalton, a Division Of Overhead Door Corporation,  
P.O. Box 67, Mt. Hope, OH., 44660, Or Online At [www.Wayne-Dalton.com](http://www.Wayne-Dalton.com)

## Important Safety Instructions

### DEFINITION OF KEY WORDS USED IN THIS MANUAL:

#### **WARNING**

**INDICATES A POTENTIALLY HAZARDOUS SITUATION WHICH, IF NOT AVOIDED, COULD RESULT IN SEVERE OR FATAL INJURY.**



**CAUTION:** PROPERTY DAMAGE OR INJURY CAN RESULT FROM FAILURE TO FOLLOW INSTRUCTIONS.

**IMPORTANT:** REQUIRED STEP FOR SAFE AND PROPER DOOR OPERATION.

**NOTE:** Information assuring proper installation of the door.

READ THESE INSTRUCTIONS CAREFULLY BEFORE ATTEMPTING INSTALLATION. IF IN QUESTION ABOUT ANY OF THE PROCEDURES, DO NOT PERFORM THE WORK. INSTEAD, HAVE A TRAINED DOOR SYSTEMS TECHNICIAN DO THE INSTALLATION OR REPAIRS.

- 1. READ AND FOLLOW ALL INSTALLATION INSTRUCTIONS.**
- Wear protective gloves during installation to avoid possible cuts from sharp metal edges.
- It is always recommended to wear eye protection when using tools, otherwise eye injury could result.
- Avoid installing your new door on windy days. Door could fall during the installation causing severe or fatal injury.
- Doors 12'-0" wide and over should be installed by two persons, to avoid possible injury.
- Operate door only when it is properly adjusted and free from obstructions.
- If a door becomes hard to operate, inoperative or is damaged, immediately have necessary adjustments and/ or repairs made by a trained door system technician using proper tools and instructions.
- DO NOT stand or walk under a moving door, or permit anybody to stand or walk under an electrically operated door.
- DO NOT place fingers or hands into open section joints when closing a door. Use lift handles/ gripping points when operating door manually.
- DO NOT permit children to operate garage door or door controls. Severe or fatal injury could result should the child become entrapped between the door and the floor.
- Due to constant extreme spring tension, do not attempt any adjustment, repair or alteration to any part of the door, especially to springs, spring brackets, bottom corner brackets, fasteners, counterbalance lift cables or supports. To avoid possible severe or fatal injury, have any such work performed by a trained door systems technician using proper tools and instructions.
- On electrically operated doors, pull down ropes must be removed and locks must be removed or made inoperative in the open (unlocked) position.
- Top section of door may need to be reinforced when attaching an electric opener. Check door and/ or opener manufacturer's instructions.
- Visually inspect door and hardware monthly for worn and or broken parts. Check to ensure door operates freely.
- Test electric opener's safety features monthly, following opener manufacturer's instructions.
- NEVER hang tools, bicycles, hoses, clothing or anything else from horizontal tracks. Track systems are not intended or designed to support extra weight.
- This door may not meet the building code wind load requirements in your area. For your safety, you will need to check with your local building official for wind load code requirements and building permit information.

**After installation is complete, fasten this manual near the garage door.**

**IMPORTANT:** STAINLESS STEEL OR PT2000 COATED LAG SCREWS MUST BE USED WHEN INSTALLING CENTER BEARING BRACKETS, END BRACKETS, JAMB BRACKETS, DRAWBAR OPERATOR MOUNTING/ SUPPORT BRACKETS AND DISCONNECT BRACKETS ON TREATED LUMBER (PRESERVATIVE-TREATED). STAINLESS STEEL OR PT2000 LAG SCREWS ARE NOT NECESSARY WHEN INSTALLING PRODUCTS ON UN-TREATED LUMBER.

**NOTE:** It is recommended that 5/16" lag screws are pilot drilled using a 3/16" drill bit, prior to fastening.

**IMPORTANT:** WHEN INSTALLING 5/16" LAG SCREWS USING AN ELECTRIC DRILL/ DRIVER, THE DRILL/ DRIVERS CLUTCH MUST BE SET TO DELIVER NO MORE THAN 200 IN-LBS OF TORQUE. FASTENER FAILURE COULD OCCUR AT HIGHER SETTINGS.

#### **WARNING**

**PRIOR TO WINDING OR MAKING ADJUSTMENTS TO THE SPRINGS, ENSURE YOU'RE WINDING IN THE PROPER DIRECTION AS STATED IN THE INSTALLATION INSTRUCTIONS. OTHERWISE, THE SPRING FITTINGS MAY RELEASE FROM SPRING IF NOT WOUND IN THE PROPER DIRECTION AND COULD RESULT IN SEVERE OR FATAL INJURY.**

**IMPORTANT:** RIGHT AND LEFT HAND IS ALWAYS DETERMINED FROM INSIDE THE BUILDING LOOKING OUT

## Tools Required

Power Drill	Locking Pliers	Tape Measure
Drill Bits: 1/8", 3/16", 9/32", 7/16", 1/2"	(2) Vice Clamps	Step Ladder
Ratchet Wrench	Wrenches: 3/8", 7/16", 1/2", 9/16", 5/8"	Level
Socket Driver: 7/16"	1/4" Torx Bit	Pencil
Sockets: 7/16", 1/2", 9/16", 5/8"	Approved Winding Rods	Leather Gloves
Phillips Head Screwdriver	Hammer	Safety Glasses

## Package Contents

**NOTE:** Depending on the door model, some parts listed will not be supplied if not required. Rear Back Hangs may not be included with your door.

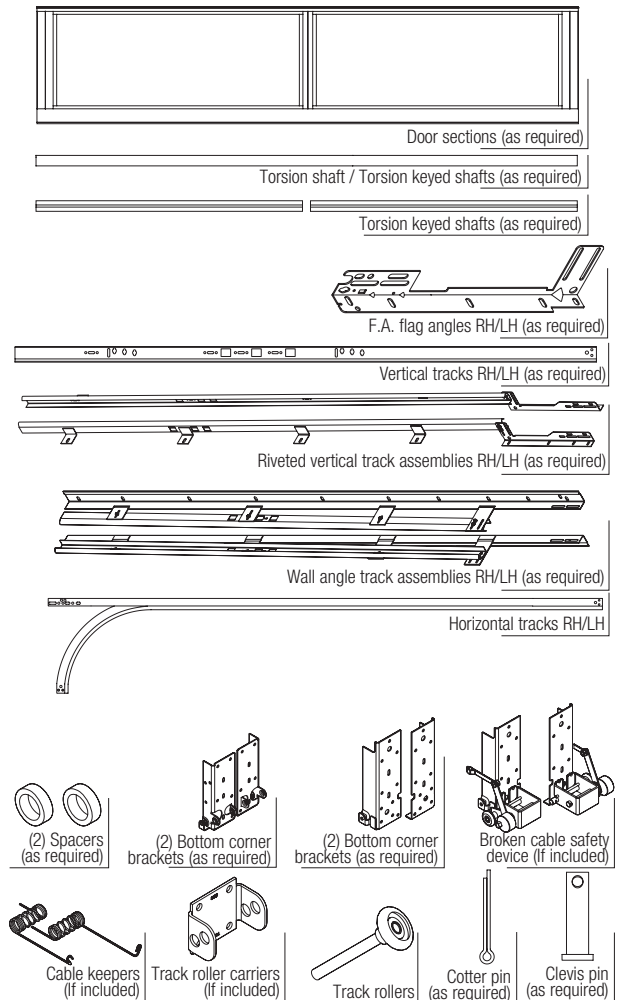

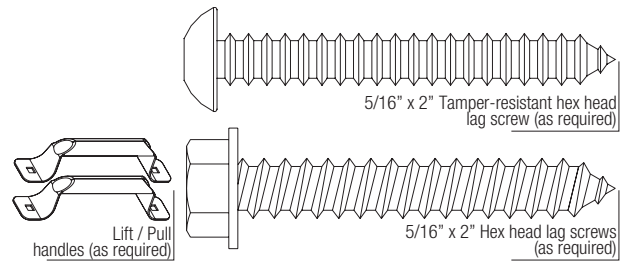
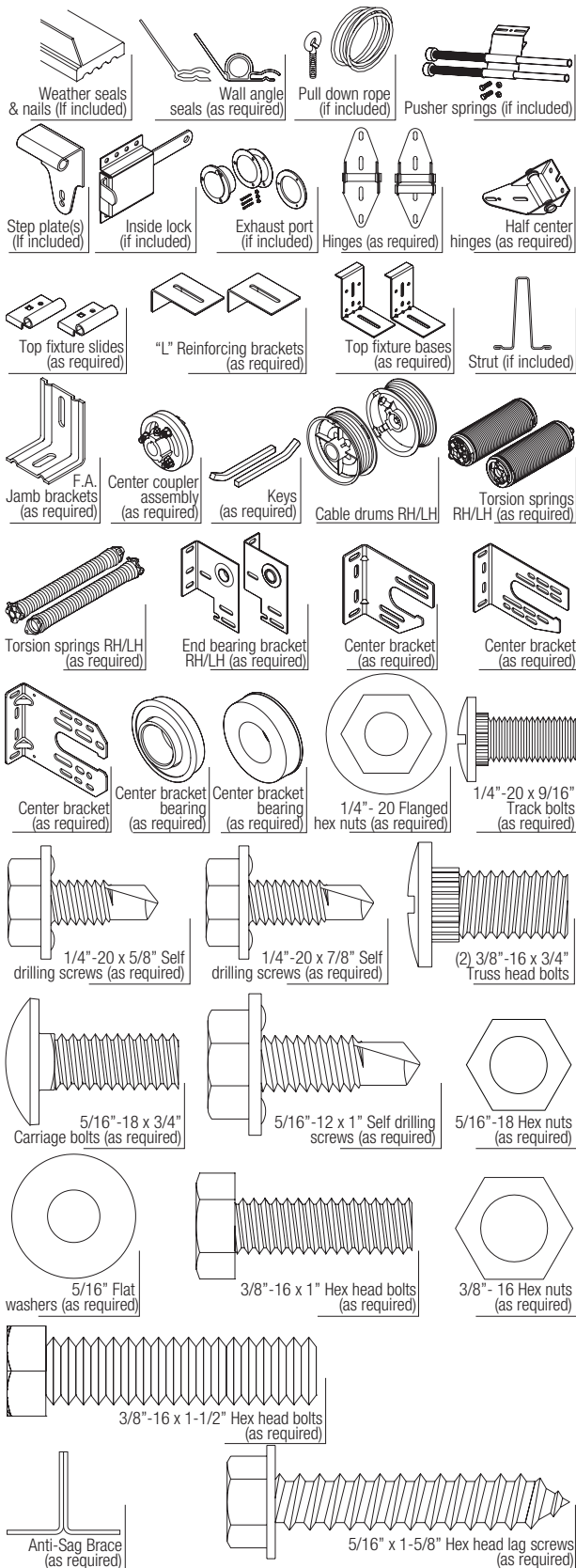

## Door Section Identification

**NOTE:** To determine your Door Section Identification, refer to the Type Of Sections chart below to determine the number of sections your door came with.

Type Of Sections	
How Many Sections High	Type Of Section
10	Top Section
9	Intermediate Section VII (As Required)
8	Intermediate Section VI (As Required)
7	Intermediate Section V (As Required)
6	Intermediate Section IV (As Required)
5	Intermediate Section III (As Required)
4	Intermediate Section II (As Required)
3	Intermediate Section I (As Required)
2	Lock Section
1	Bottom Section

When installing your door you must use sections of the appropriate height in the right stacking order. What sections heights you need to use in what order depends on the height of your door. Sections are either 24", 21" or 19-1/2" in Section Height.

**NOTE:** If you have different sections heights, the tallest (24" / 21") sections heights are always stacked at the bottom and the smaller 21" / 19-1/2" sections height stacked to the top. Unless your door is three sections height, you will not receive an Intermediate I section.

**NOTE:** If you have Model 8450, the door height only goes up to or equal to 8'0", 4 sections high.

**NOTE:** If you have Model 464, the door height only goes up to or equal to 14'0", 7 sections high.

**NOTE:** If you have Model 451, the door height only goes up to or equal to 20'0", 10 sections high.

**NOTE:** If you have Model 452, the door height only goes up to or equal to 14'0", 7 sections high.

When installing your door you must use sections of the appropriate height in the right stacking order. What sections heights you need to use in what order depends on the height of your door.

Unless your door is five sections in height, you will not receive an Intermediate II section.

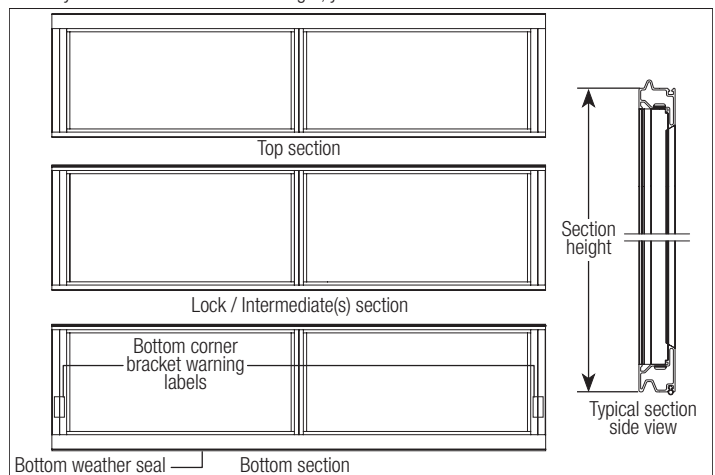

## Removing an Existing Door

**IMPORTANT:** COUNTERBALANCE SPRING TENSION MUST ALWAYS BE RELEASED BEFORE ANY ATTEMPT IS MADE TO START REMOVING AN EXISTING DOOR.

### WARNING

**A POWERFUL SPRING RELEASING ITS ENERGY SUDDENLY CAN CAUSE SEVERE OR FATAL INJURY. TO AVOID INJURY, HAVE A TRAINED DOOR SYSTEMS TECHNICIAN, USING PROPER TOOLS AND INSTRUCTIONS, RELEASE THE SPRING TENSION.**

For detailed information see supplemental instructions "Removing an Existing Door / Preparing the Opening". These instructions are not supplied with the door, but are available at no charge from Wayne Dalton, A Division Of Overhead Door Corporation, P.O. Box 67, Mt. Hope, OH., 44660, or at [www.Wayne-Dalton.com](http://www.Wayne-Dalton.com).

## Preparing the Opening

**IMPORTANT:** IF YOU JUST REMOVED YOUR EXISTING DOOR OR YOU ARE INSTALLING A NEW DOOR, COMPLETE ALL STEPS IN PREPARING THE OPENING.

To ensure secure mounting of track brackets, side and center brackets, or steel angles to new or retro-fit construction, it is recommended to follow the procedures outlined in DASMA technical data sheets #156, #161 and #164 at [www.dasma.com](http://www.dasma.com).

The inside perimeter of your garage door opening should be framed with wood jamb and header material. The jambs and header must be securely fastened to sound framing members. It is recommended that 2" x 6" lumber be used. The jambs must be plumb and the header level. The jambs should extend a minimum of 12" (305 mm) above the top of the opening for Torsion counterbalance systems. For low headroom applications, the jambs should extend to the ceiling height.

Minimum side clearance required, from the opening to the wall, is 3-1/2" (89 mm), for 2" track.

Minimum side clearance required, from the opening to the wall, is 4-1/2" (114 mm), for 3" track.

**IMPORTANT:** CLOSELY INSPECT JAMBS, HEADER AND MOUNTING SURFACE. ANY WOOD (IF APPLICABLE) FOUND NOT TO BE SOUND, MUST BE REPLACED.

For Torsion counterbalance systems, a suitable mounting surface (2" x 6") must be firmly attached to the wall, above the header at the center of the opening.

**NOTE:** Drill a 3/16" pilot hole in the mounting surface to avoid splitting the lumber. Do not attach the mounting surface with nails.

### WEATHERSTRIPS (MAY NOT BE INCLUDED):

Depending on the size of your door, you may have to cut or trim the weatherstrips (if necessary) to properly fit into the header and jambs.

**NOTE:** Prior to installing, weatherstrips / jamb seals should be warmed to room temperature when installed in cold climate weather.

**NOTE:** If nailing product at 40°F or below, pre-drilling is required.

**NOTE:** Do not permanently attach weatherstrips to the header and jambs at this time.

For the header, align the weatherstrip 1/8" to 1/4" inside the header edge, and temporarily secure it to the header with equally spaced nails. Starting at either side of the jamb, fit the weatherstrip up tight against the temporarily attached weatherstrip in the header and 1/8" to 1/4" inside the jamb edge. Temporarily secure the weatherstrip with equally spaced nails. Repeat for other side. This will keep the bottom section from falling out of the opening during installation. Equally space nails approximately 12" to 18" apart.

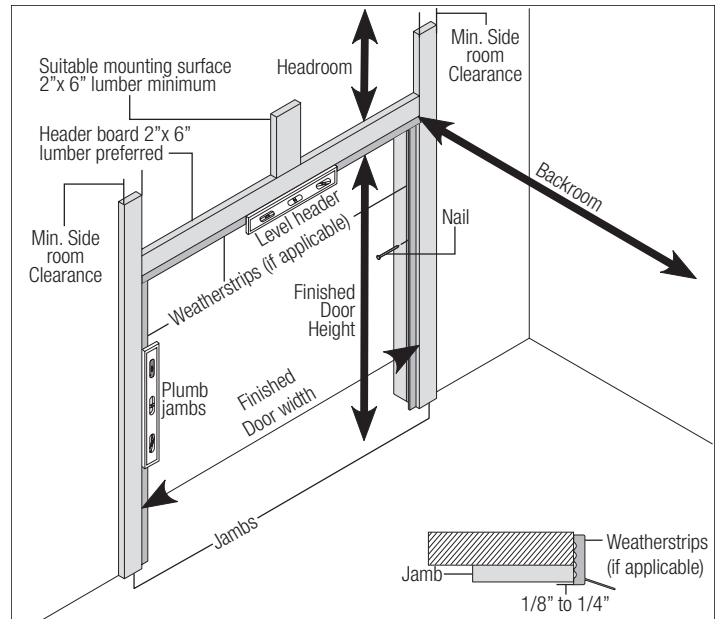

**HEADROOM REQUIREMENT:** Headroom is defined as the space needed above the top of the door for tracks, springs, etc. to allow the door to open properly. If the door is to be motor operated, 2-1/2" (64 mm) of additional headroom is required.

**DIMENSION (DIM.) "Y":** Indicates the distance from the header to the center line of torsion shaft.

**NOTE:** 2-1/2" of additional headroom is required for single trolley operator installations.

**NOTE:** Headroom can be reduced 2-1/2" by using the quick closing top fixture or by shortening the vertical tracks by 3" max.

### HEADROOM REQUIREMENTS (MINIMUM DISTANCE REQUIRED)

Cable Drums	Dimensions	3" Track, 15" Radius	2" Track, 15" Radius	2" Track, 12" Radius
400-8	Headroom Dim. "Y"	15-1/2"	14-1/2"	12-1/2"
400-12		13"	12"	9"
5250-18		19"	18"	15"
		14-1/2"	13-1/2"	10-1/2"
800-32		21"	20"	17"
		16-1/2"	15"	12-1/2"

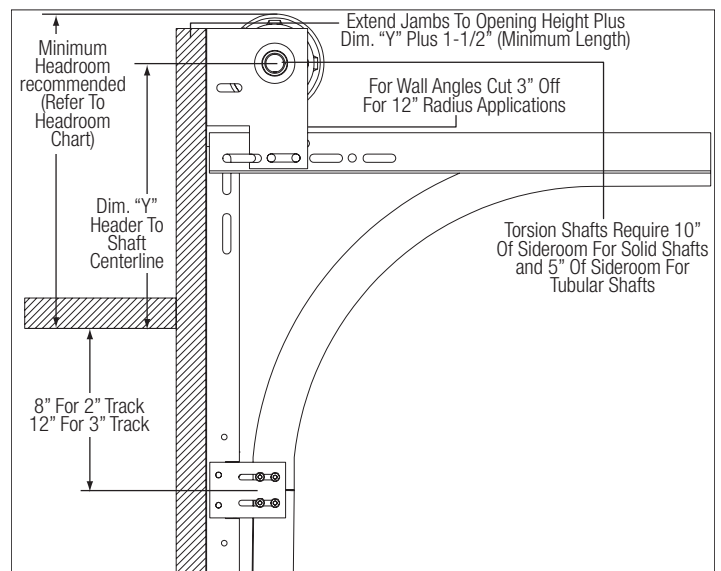

**BACKROOM REQUIREMENT:** Backroom is defined as the distance needed from the opening back into the garage to allow the door to open fully.

### BACKROOM REQUIREMENTS (MINIMUM DISTANCE REQUIRED)

Track size	Manual Depth Into room	Dim. "A" Side room track		Dim. "B" Side room Torsion Shaft	
		Steel	Masonry / Wood	Solid	Tube
2"	Door Height Plus 18", Motor Plus 66"	3-1/2"	4"	10"	5"
3"	Door Height Plus 24", Motor Plus 66"	4"	5"	10"	5"

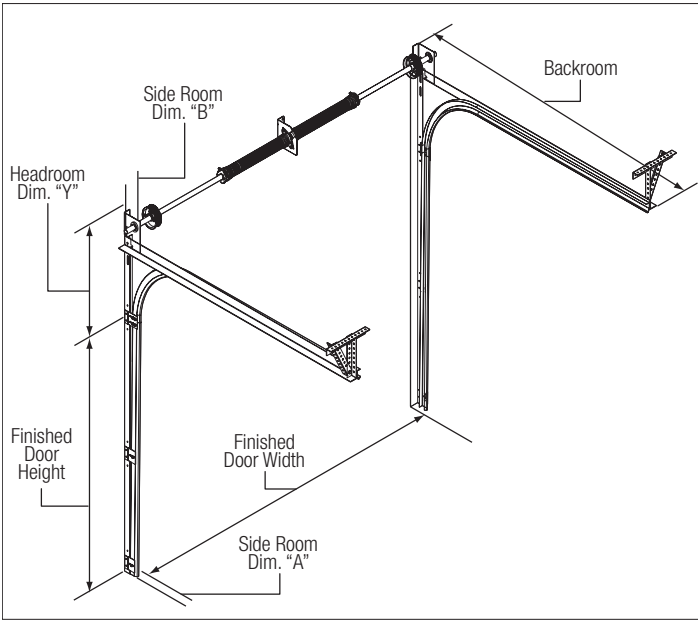

**SIDE ROOM REQUIREMENTS:** Side room is defined as the distance needed from the door opening to a wall or any obstruction.

**SIDE ROOM REQUIREMENTS (MINIMUM DISTANCE REQUIRED)**

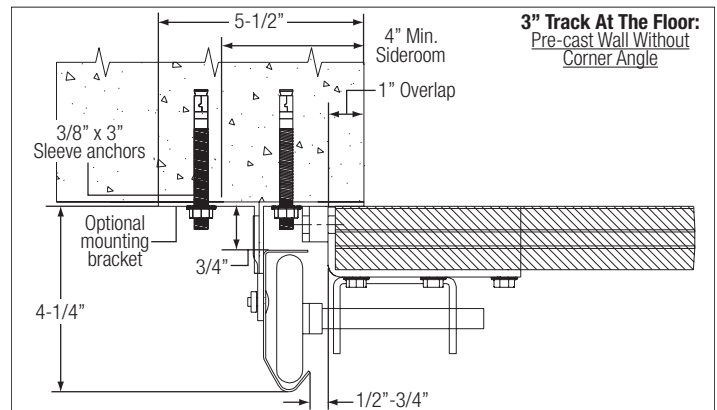
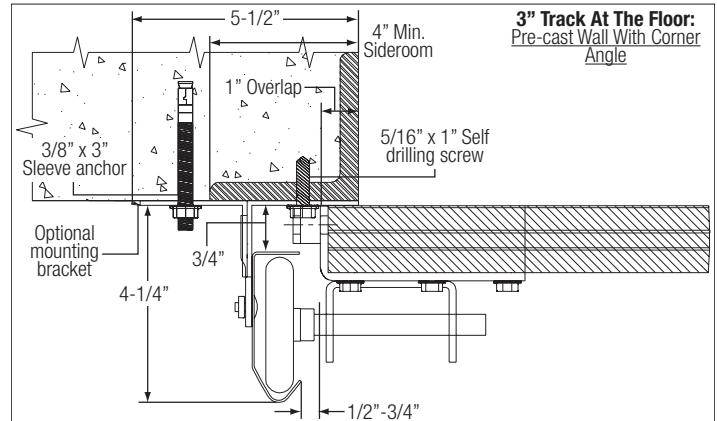
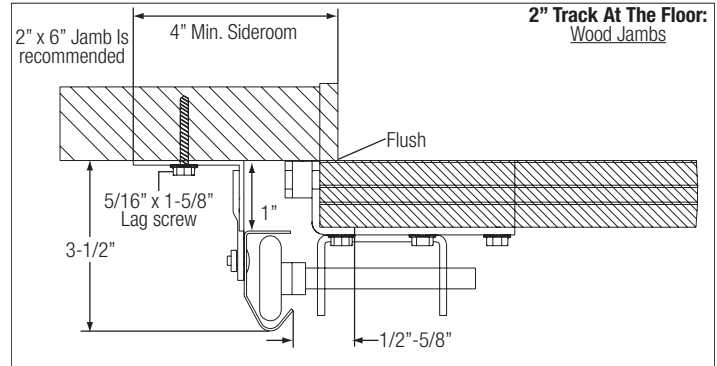
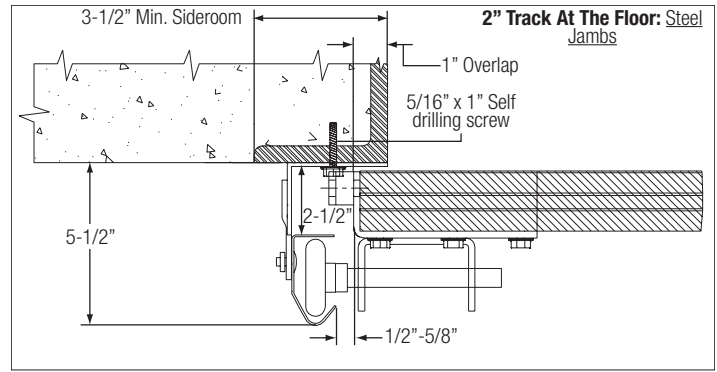
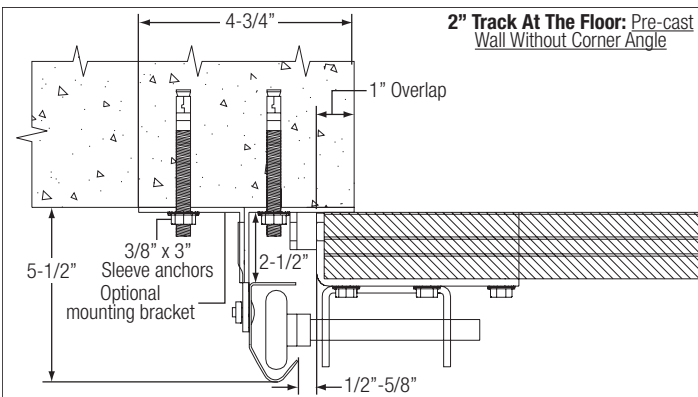
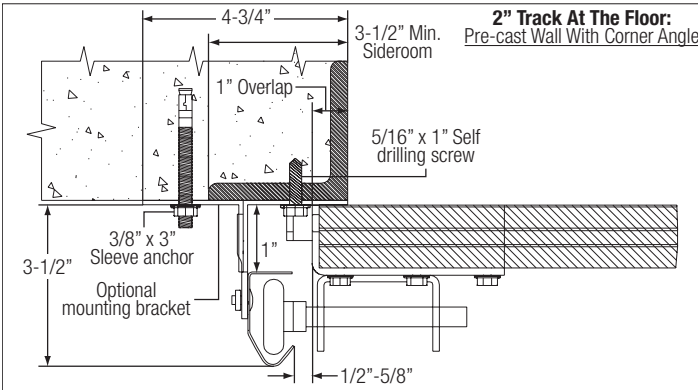

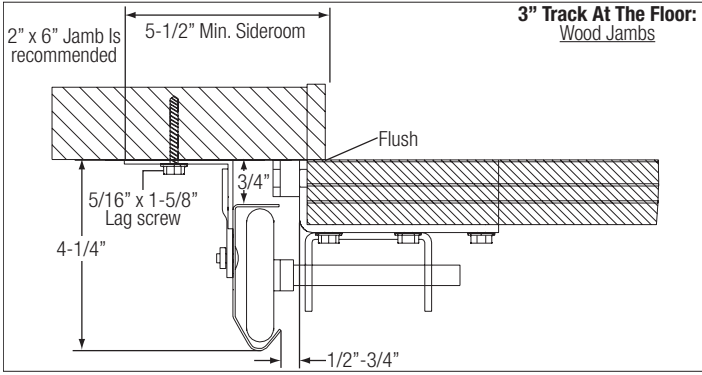
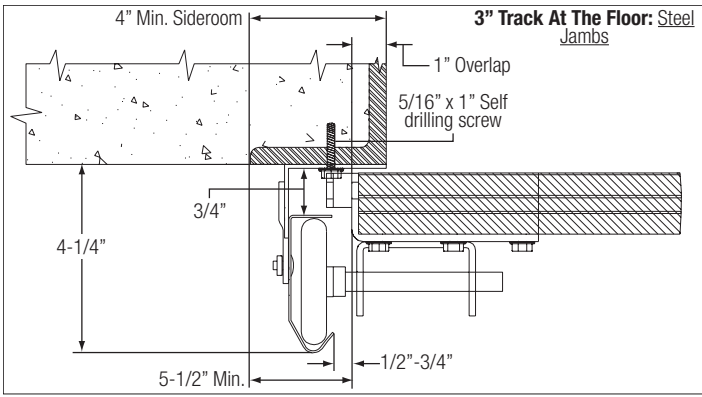

# PARTS BREAKDOWN

**NOTE:** The illustrations shown on this page are general representations of the door parts. Each specific door models may have unique variations.

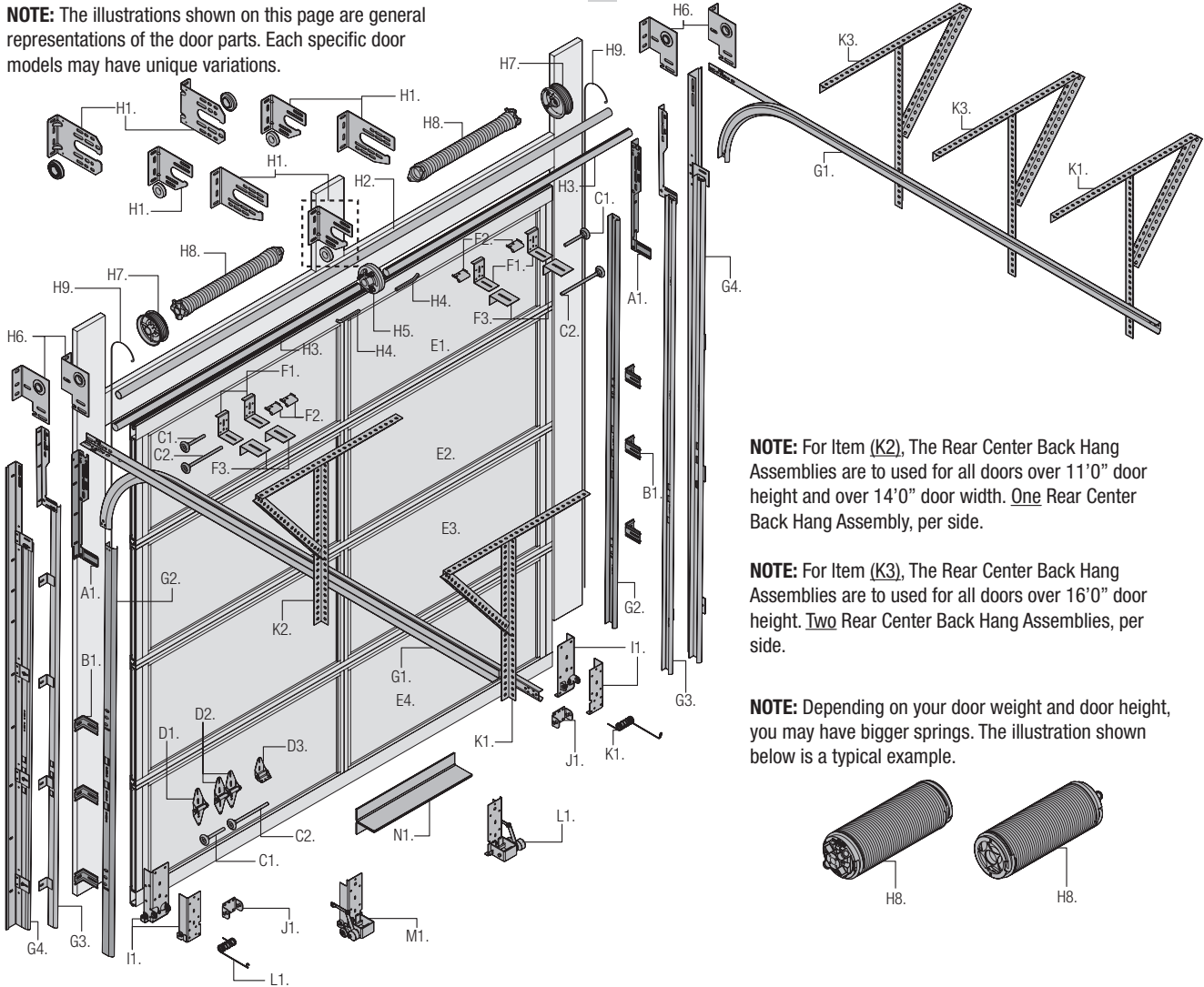

**NOTE:** For Item (K2), The Rear Center Back Hang Assemblies are to be used for all doors over 11'0" door height and over 14'0" door width. One Rear Center Back Hang Assembly, per side.

**NOTE:** For Item (K3), The Rear Center Back Hang Assemblies are to be used for all doors over 16'0" door height. Two Rear Center Back Hang Assemblies, per side.

**NOTE:** Depending on your door weight and door height, you may have bigger springs. The illustration shown below is a typical example.

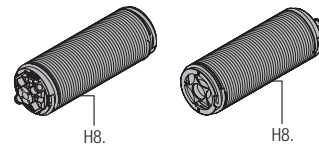

## A. FLAG ANGLES (AS REQUIRED):

A1. Fully Adjustable (F.A.) Flag Angles

## B. JAMB BRACKETS (AS REQUIRED):

B1. Fully Adjustable (F.A.) Jamb Brackets

## C. TRACK ROLLERS (AS REQUIRED):

C1. Short Stem Track Rollers / C2. Long Stem Track Rollers

## D. GRADUATED END HINGES:

D1. Single Graduated End Hinges (S.E.H.), Industry Standard  
 D2. Double Graduated End Hinges (D.E.H.), Industry Standard  
 D3. Half Center Hinges (As Required)

## E. STACKED SECTIONS:

E1. Top Section  
 E2. Intermediate(s) Section  
 E3. Lock Section  
 E4. Bottom Section

## F. TOP FIXTURES:

F1. Top Fixture Bases  
 F2. Top Fixture Slides  
 F3. "L" Reinforcing Brackets (As Required)

## G. TRACKS (AS REQUIRED):

G1. Left Hand and Right Hand Horizontal Track Assemblies  
 G2. Left Hand and Right Hand Vertical Tracks  
 G3. Left Hand and Right Hand Vertical Track Assemblies  
 G4. Left Hand and Right Hand Wall Angle Track Assemblies

## H. TORSION SPRING ASSEMBLY (AS REQUIRED):

H1. Center Bracket(s) With Center Bracket Bearing(s) (As Required)  
 H2. Torsion Shaft / Torsion Keyed Shaft (As Required)  
 H3. Torsion Keyed Shafts (As Required)  
 H4. Keys (As Required)  
 H5. Center Coupler Assembly (As Required)  
 H6. Left Hand And Right Hand End Bearing Brackets  
 H7. Left Hand And Right Hand Cable Drums  
 H8. Left Hand and Right Hand Torsion Springs (As Required)  
 H9. Counterbalance Lift Cables

## I. BOTTOM CORNER BRACKETS (AS REQUIRED):

I1. Left and Right Hand Bottom Corner Brackets

## J. BOTTOM CORNER BRACKET TRACK ROLLER CARRIERS (AS REQUIRED):

J1. Bottom Corner Bracket Track Roller Carriers

## K. REAR BACK HANGS:

K1. Left and Right Hand Rear Back Hangs Assemblies  
 K2. Left and Right Hand Rear Center Back Hang Assemblies (As Required)  
 K3. Left and Right Hand Rear Center Back Hang Assemblies (As Required)

## L. CABLE KEEPERS (AS REQUIRED):

L1. Cable Keepers

## M. BROKEN CABLE SAFETY DEVICES (AS REQUIRED):

M1. Left Hand And Right Hand Broken Cable Safety Devices

## N. ANTI-SAG BRACE (AS REQUIRED):

N1. Anti-Sag Brace

# INSTALLATION

Before installing your door, be certain that you have read and followed all of the instructions covered in the pre-installation section of this manual. Failure to do so may result in an improperly installed door.

**NOTE:** Reference TDS 160 for general garage door terminology at [www.dasma.com](http://www.dasma.com).

## 1 Fully Adjustable Flag Angles

Tools Required: Safety glasses, Leather gloves

1

**NOTE:** If you have Riveted Track or Angle Mount Track, skip this step.

**NOTE:** Flag angles are right and left handed.

If you have Fully Adjustable vertical tracks, hand tighten the left hand flag angle to the left hand vertical track using (2) 1/4" - 20 x 9/16" track bolts and (2) 1/4" - 20 flange hex nuts. Repeat for other side. Flange nuts will be secured after flag angle spacing is completed in step, Top Section.

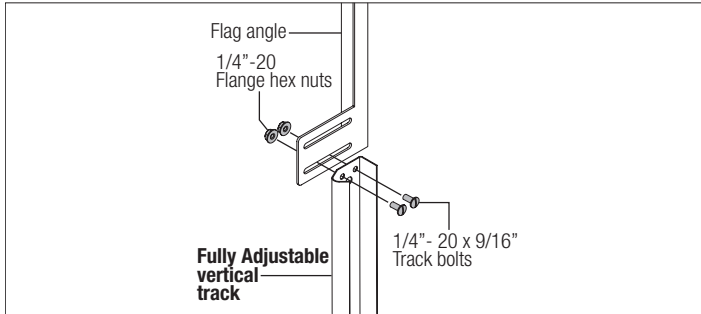

## 2 Fully Adjustable Jamb Brackets

Tools Required: Tape measure, Safety glasses, Leather gloves

2

**NOTE:** If you have Riveted Track or Angle Mount Track, skip this step.

**NOTE:** The bottom jamb bracket is always the shortest bracket, while the center jamb bracket is the next tallest. If three jamb brackets per side are included with your door, you will have received a top jamb bracket, which is the tallest.

To attach the bottom jamb bracket, locate lower hole of the hole/ slot pattern of the 1st hole set on the vertical track. Align the slot in the jamb bracket with the lower hole of the hole/ slot pattern. Secure jamb bracket using (1) 1/4" - 20 x 9/16" track bolt and (1) 1/4" - 20 flange hex nut. Repeat for other side.

Place the center jamb bracket over the lower hole of the hole/ slot pattern that is centered between the bottom jamb bracket and flag angle of the 2nd hole set. Secure jamb bracket using (1) 1/4" - 20 x 9/16" track bolt and (1) 1/4" - 20 flange hex nut. Repeat for other side.

If a top jamb bracket was included, secure it to vertical track using the lower hole of the hole/ slot pattern in the 3rd hole set and (1) 1/4" - 20 x 9/16" track bolt and (1) 1/4" - 20 flange hex nut. Repeat for other side.

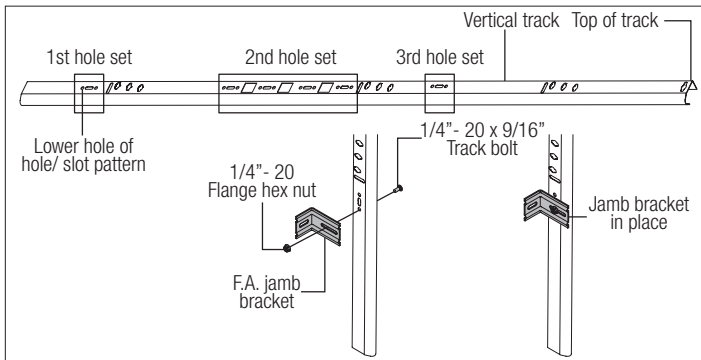

## 3 Bottom Corner Brackets

Tools Required: Power drill, 7/16" Socket driver, Tape measure, Safety glasses, Leather gloves

3

**NOTE:** Refer to door section identification, located in the pre-installation section of this manual. Refer to Package Contents / Parts Breakdown, to determine which bottom corner brackets you have received.

Uncoil the counterbalance lift cables and locate the left hand bottom corner bracket. Starting on the left hand side, place the cable loop into position between the two holes on the side of the left hand bottom bracket. Slide a clevis pin through the innermost hole, cable loop, and outermost hole, of the bottom corner bracket. Secure the clevis pin in place by inserting a cotter pin into the hole of the clevis pin. Bend the ends of the cotter pin outwards to secure it

in place. Repeat for other side.

**IF YOU DID NOT RECEIVE AN ANTI-SAG BRACE:** Next, align the bottom corner bracket horizontally with the bottom edge of the bottom section and also align the bottom corner bracket vertically with the left bottom edge of the bottom section. Attach each bottom corner brackets to the bottom section using the appropriate 1/4" - 20 x 7/8" self drilling screws, as shown.

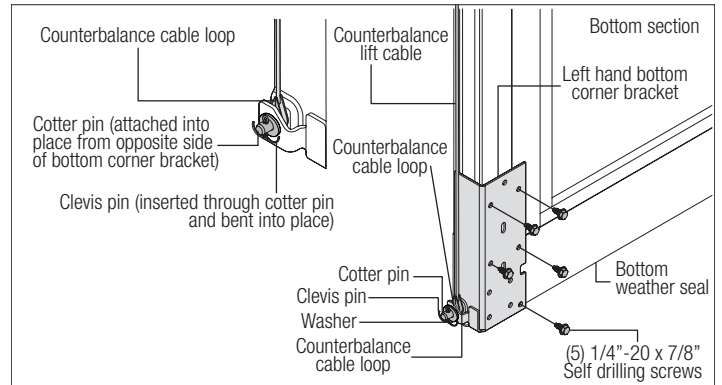
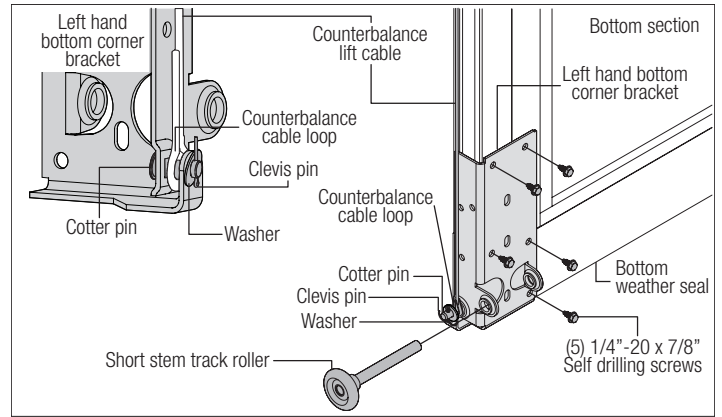

**IF YOU DID RECEIVE AN ANTI-SAG BRACE:** Next, align the bottom corner bracket horizontally with the bottom edge of the bottom section and also align the bottom corner bracket vertically with the left bottom edge of the bottom section. With the bottom corner brackets in position on the bottom section, locate and center the anti-sag brace onto the bottom section surface and against the roller carriers of the bottom corner brackets. Secure the anti-sag brace and the bottom corner brackets to the bottom section using (2) 1/4" - 20 x 7/8" self drilling screws at each end stile. Next, secure the anti-sag brace to the bottom section using (2) 1/4" - 20 x 7/8" self drilling screws at each center stile location(s). Finish securing the bottom corner bracket to the bottom section using 1/4" - 20 x 7/8" self drilling screws, as shown above.

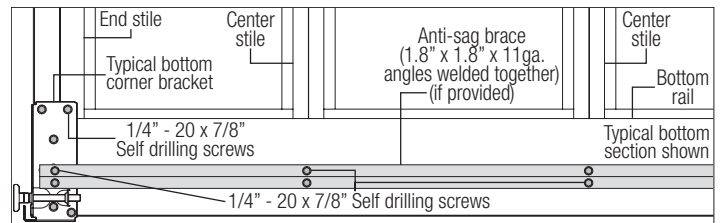

**NOTE:** If you have broken cable safety devices, only install the top (4) 1/4" - 20 x 7/8" self drilling screws to secure the bottom corner bracket to the bottom section. Reference Step Broken Cable Safety Devices.

**NOTE:** If you did not receive Track Roller Carriers or Cable Keepers, then insert a short stem track roller with roller spacer into each of the bottom corner brackets, as shown.

**NOTE:** Verify that the bottom weather seal (bottom seal) is aligned with door section. If there is more than 1/2" excess bottom weather seal on either side, trim bottom weather seal even with door section.

## 4 Track Roller Carriers

Tools Required: Power drill, 9/32" Drill bit, Socket driver 7/16", Wrench 7/16", Safety glasses, Leather gloves

4

**NOTE:** If you don't have track roller carriers, then skip this step. Refer to Package Contents / Parts Breakdown, to determine if you have track roller carriers.

Starting on left hand side of the bottom section, attach the track roller carrier with the stamp "STD" facing UP to the bottom corner bracket by aligning the four holes of the track roller carrier with the four holes in the bottom corner bracket. Secure the track roller carrier to the bottom corner bracket with (4) 1/4" - 20 x 7/8" self drilling screws.

**NOTE:** If you did not receive cable keepers, then insert a short stem track roller with roller spacer into each of the bottom corner brackets, as shown.



**IMPORTANT:** THE TRACK ROLLER CARRIER'S INNER HOLES ARE USED ON DOORS WITH 2" TRACK APPLICATIONS; THE OUTER HOLES ARE USED ON DOORS WITH 3" TRACK APPLICATIONS.

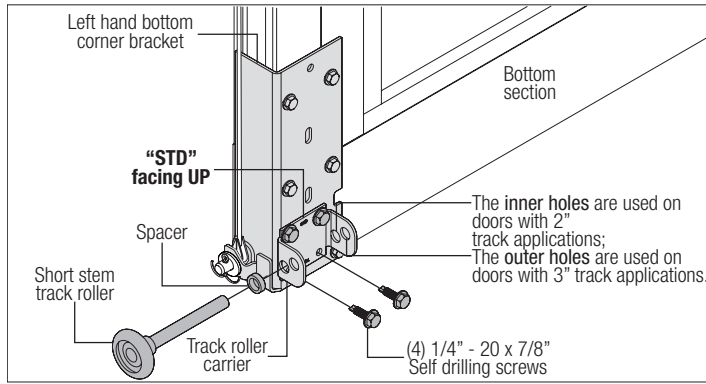

5

### Cable Keepers

Tools Required: Power drill, 9/32" Drill bit, Socket driver 7/16", Wrench 7/16", Safety glasses, Leather gloves

**NOTE:** If you don't have cable keepers, then skip this step. Refer to Package Contents / Parts Breakdown, to determine if you have cable keepers.

**IMPORTANT:** CABLE KEEPERS ARE INTENDED TO HELP PREVENT COUNTERBALANCE LIFT CABLES FROM COMING OFF CABLE DRUMS ON MANUALLY OPERATED DOORS.

**NOTE:** Cable keepers are right hand and left hand.

**NOTE:** Cable keepers are color coded, black for right hand and red for left hand.

Locate the left hand cable keeper. Starting on the left hand side of bottom section, position the left hand cable keeper in between the roller carrier tabs. Insert a short stem track roller with roller spacer through the holes in the tabs and through the cable keeper. Repeat the same process for the right hand side.

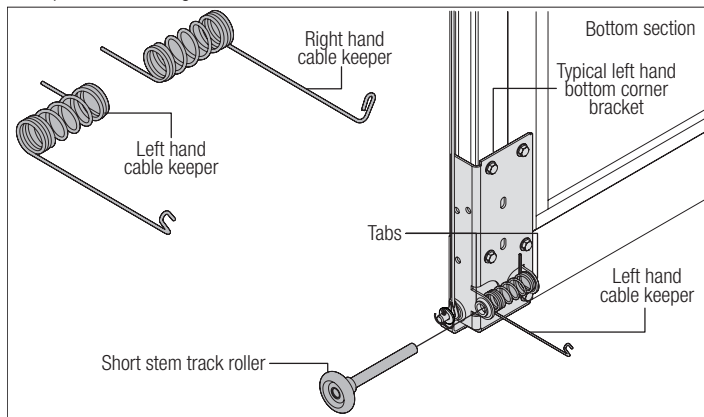

6

### Broken Cable Safety Device

Tools Required: Power drill, Socket driver 7/16", Wrench 7/16", Safety glasses, Leather gloves

**NOTE:** If you don't have broken cable safety devices, then skip this step. Refer to Package Contents / Parts Breakdown, to determine if you have broken cable safety devices.

Starting on left hand side of the bottom section, align the broken cable safety device horizontally with the bottom edge of the bottom section and also align the broken cable safety device vertically with the left bottom edge of the bottom section. Attach the broken cable safety device to the bottom section with (4) 1/4" - 20 x 7/8" self drilling screws. Rotate the cam arm upward and slide the counterbalance lift cable through the arm, as shown. Repeat the same process for the right hand side.

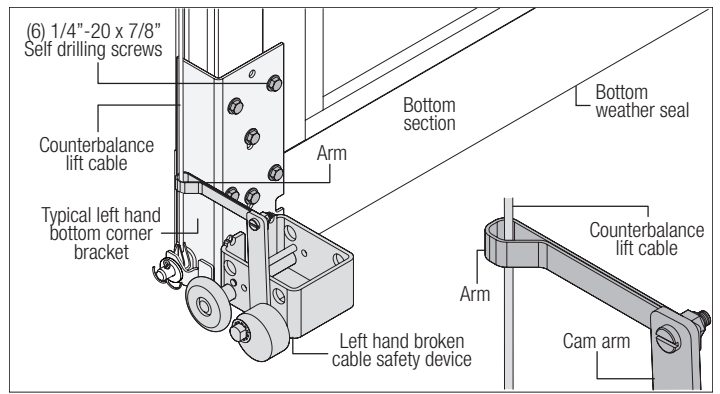

7

### Graduated Hinge Attachment

Tools Required: Power drill, Socket driver 7/16", Wrench 7/16", Safety glasses, Leather gloves

**NOTE:** Refer to door section identification, located in the pre-installation section of this manual.

**NOTE:** The graduated hinges can be identified by the number stamped onto their lower hinge leaf.

The graduated end hinge sequence is dependent on your track size (2" or 3"). Refer to Graduated End Hinge Schedule.

Section Type	Graduated End Hinge Schedule	
	Graduated End hinge Number	
	2" Track	3" Track
Intermediate VII	#9	#11
Intermediate VI	#8	#10
Intermediate V	#7	#9
Intermediate IV	#6	#8
Intermediate III	#5	#7
Intermediate II	#4	#6
Intermediate I	#3	#5
Lock	#2	#4
Bottom	#1	#3

**IF YOU HAVE SINGLE END STILES:** Locate the bottom section, (2) #1/#3 graduated end hinges for the end stiles. Starting on the left hand side of the bottom section, align the lower hinge leaf of the #1/#3 graduated end hinge over the two punch marks, located at the top of the single end stile. Attach lower hinge leaves to the section using (2) 1/4" - 20 x 7/8" self drilling screws. Repeat the same process for the right hand side. Place a short stem track roller into each graduated end hinges.

**IF YOU HAVE DOUBLE END STILES:** Locate the bottom section, (2) #1/#3 graduated end hinges for the end. Starting on the left hand side of the bottom section, align the lower hinge leaf of the #1/#3 graduated end hinge over the two punch marks, located at the top of the double end stile. Attach lower hinge leaves to the section using (4) 1/4" - 20 x 7/8" self drilling screws. Repeat the same process for the right hand side. Place a long stem track roller into each graduated end hinges.

**TO INSTALL CENTER HINGES ON SECTIONS WITH NO FINS:** Place the center hinge over the center stile, using the center line of the stile as a guide. Secure the center hinge to the section using (2) 1/4" - 20 x 7/8" self drilling screws, as shown. Repeat the same process for other center hinge(s).

**TO INSTALL HALF CENTER HINGES ON SECTIONS WITH FINS:** Position the half center hinge on top of the fin and in front of the center stile. Align the bottom (2) holes in the half center hinge over the (2) pre-punch holes in the fin. Secure the half center hinge to the fin using (2) 1/4" - 20 x 9/16" track bolts and (2) 1/4" x 20 flange hex nuts, as shown. Repeat the same process for the other half center hinges.

**IMPORTANT:** ONCE THE 1/4" - 20 X 7/8" SELF DRILLING SCREWS ARE SNUG AGAINST THE LOWER HINGE LEAFS, TIGHTEN AN ADDITIONAL 1/4 TO 1/2 TURN TO RECEIVE MAXIMUM DESIGN HOLDING POWER.

**IMPORTANT:** PUSH & HOLD THE HINGE LEAF SECURELY AGAINST THE SECTION WHILE SECURING WITH 1/4" - 20 X 7/8" SELF DRILLING SCREWS. THERE SHOULD BE NO GAP BETWEEN THE HINGE LEAF AND THE SECTION.

Repeat graduated end hinge / center hinge / half center hinge attachment using the appropriate graduated end hinges for all remaining sections, except for the top section.

**IMPORTANT:** WHEN PLACING TRACK ROLLERS INTO THE #2 GRADUATED END HINGES AND HIGHER, THE TRACK ROLLER GOES INTO HINGE TUBE FURTHEST AWAY FROM SECTION.

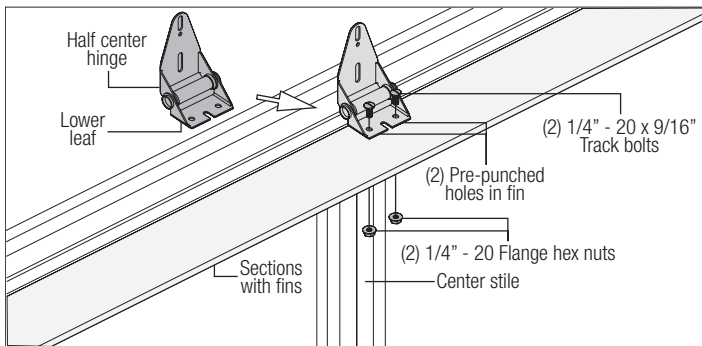
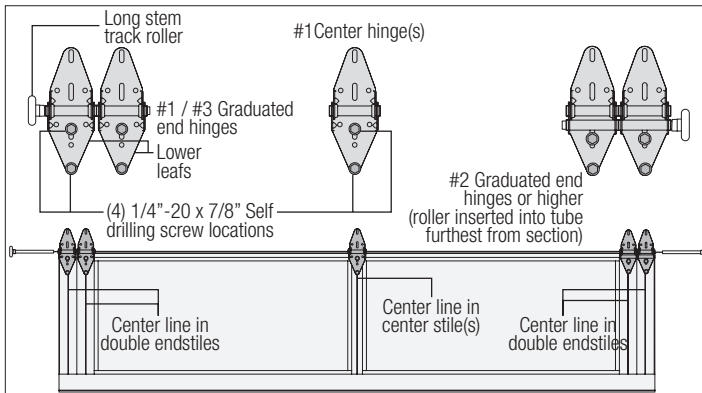
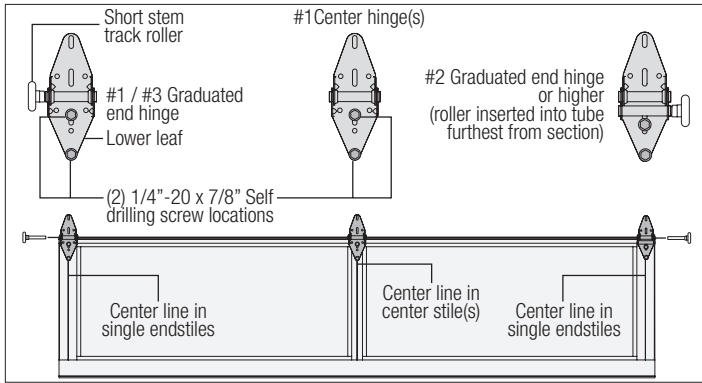

## 8 Top Fixtures

Tools Required: Power drill, 7/16" Socket driver, (2) Saw horses, Tape measure, Safety glasses, Leather gloves

**NOTE:** Refer to Door Section Identification / Parts Breakdown.

**NOTE:** If your door came with two top fixtures, then one top fixture and a short stem track roller are required for each side.

**NOTE:** If your door came with four top fixtures, then two top fixtures and a long stem track roller are required for each side.

Loosely secure the top fixture slide and the "L" reinforcement bracket (if applicable) to the top fixture base using (1) 5/16" - 18 x 3/4" carriage bolt and (1) 5/16" - 18 hex nut, as shown. Repeat for other top fixture assembly(s). Starting on the left hand side of the top section, align the lip of the top fixture base on top of the corner of the top section and even with the edge of the section. Fasten to the top section using (4) 1/4" - 20 x 7/8" self drilling screws. Fasten the "L" reinforcement bracket (if applicable) to the section using (1) 1/4" - 20 x 7/8" self drilling screw. Repeat the same process for other top fixture assembly(s). Insert short/long stem track roller into top fixture slide(s). The top fixture assembly will be tightened and adjusted later, in step, Adjusting Top Fixtures.

**NOTE:** If your door is to be trolley operated, it is recommended that an optional strut be installed along the top rail.

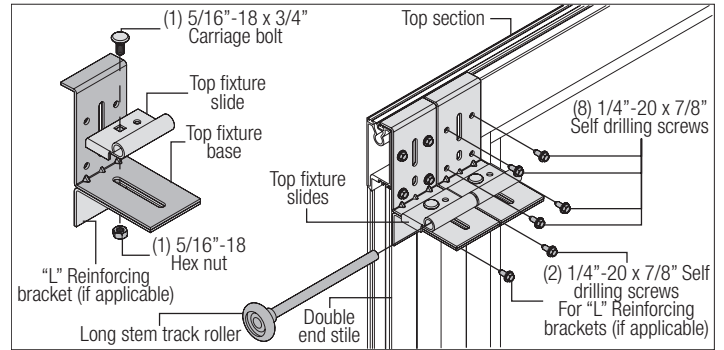
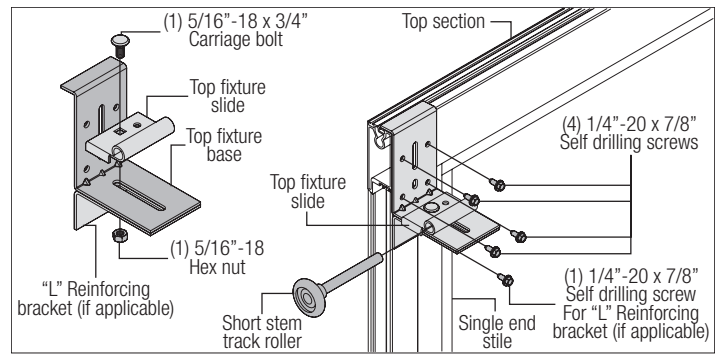

## 9 Bottom Section

Tools Required: Level, Wooden shims (if necessary), Tape measure, Safety glasses, Leather gloves

Center the bottom section in the door opening. Level the section using wooden shims (if necessary) under the bottom section. When the bottom section is leveled, temporarily hold it in place by driving a nail(s) into the jamb and bending it over the edge of the bottom section on both sides.

**NOTE:** For wider size doors, more than two wooden shims (shown in illustration) might be needed to level the bottom section.

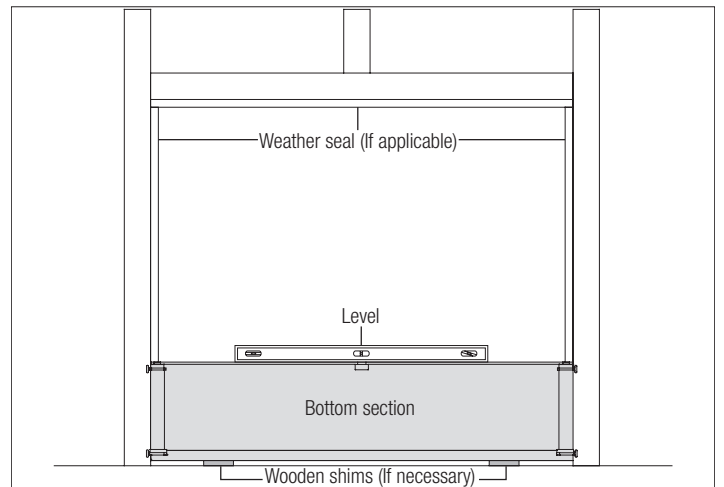

## 10 Wall Angle Seal

Tools Required: Safety glasses, Leather gloves

**NOTE:** If you don't have wall angle seals, then skip this step. Refer to Package Contents and or illustrations below, to determine which wall angle seals you have received.

Starting with the left hand wall angle, align the profile of the wall angle seal with the inside edge of wall angle. Next, slide wall angle seal over the inside edge of wall angle until seal is flush up against the edge of wall angle, as shown. Repeat the same process for the right hand side wall angle.

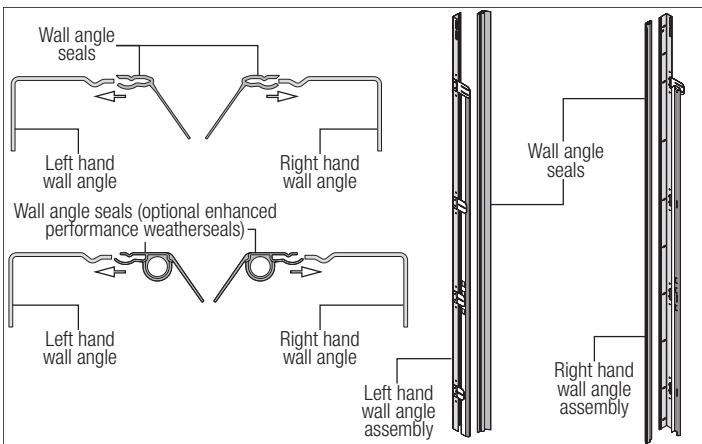

11

## Vertical Tracks

Tools Required: Power drill, 3/16" Drill bit, 7/16" Socket driver, Tape measure, Level, Step ladder, Safety glasses, Leather gloves

**NOTE:** Depending on your door, you may have Fully Adjustable Flag Angles, Riveted Vertical Track Assemblies or you may have Angle Mount Vertical Track Assemblies. Refer to Package Contents / Parts Breakdown, to determine which Flag Angles / Vertical Track Assemblies you have.

**IMPORTANT:** IF YOUR DOOR IS TO BE INSTALLED PRIOR TO A FINISHING CONSTRUCTION OF THE BUILDING'S FLOOR, THE VERTICAL TRACKS AND THE DOOR BOTTOM SECTION ASSEMBLY SHOULD BE INSTALLED SUCH THAT WHEN THE FLOOR IS CONSTRUCTED, NO DOOR OR TRACK PARTS ARE TRAPPED IN THE FLOOR CONSTRUCTION.

**IMPORTANT:** THE TOPS OF THE VERTICAL TRACKS MUST BE LEVEL FROM SIDE TO SIDE. IF THE BOTTOM SECTION WAS SHIMMED TO LEVEL IT, THE VERTICAL TRACK ON THE SHIMMED SIDE MUST BE RAISED THE HEIGHT OF THE SHIM.

Starting on the left hand side, remove the nail holding the bottom section to jamb. Position the left hand vertical track assembly / wall angle track assembly over the track rollers of the bottom section. Make sure the counterbalance lift cable is located between the track rollers and the door jamb.

### LOOSELY FASTEN WALL ANGLES TO ONE OF THE FOLLOWING SCENARIOS LISTED BELOW:

Wood jambs, using 5/16" x 1-5/8" lag screws. Drill 3/16" pilot holes into the wood jamb for the lag screws.

Steel jambs, using 5/16" x 1" self drilling screws.

Pre-cast concrete, using 3/8" x 3" sleeve anchor (not supplied).

**NOTE:** Products being installed to pre-cast or block must use a 3/8" x 3" sleeve anchor to attach the wall angle to the building, as shown. Use the slots in the wall angle as a drill template and drill a 3/8" hole (3-1/2" deep) and secure to anchor.

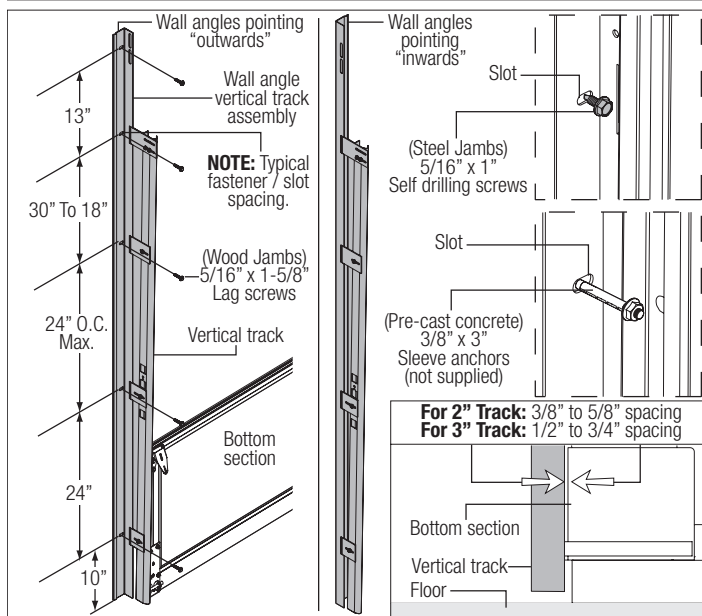
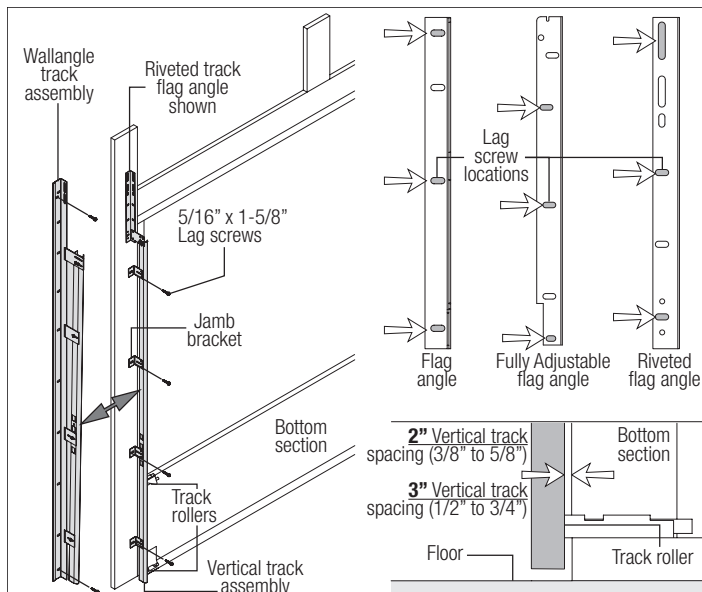

## WARNING

DO NOT USE SLEEVE ANCHORS ON HOLLOW BLOCK.

**FOR 2" TRACK:** Tighten fasteners, securing the bottom jamb bracket in the vertical track assemblies / bottom slot in the wall angle to jamb, maintain 3/8" to 5/8" spacing, between the bottom section and vertical track.

**FOR 3" TRACK:** Tighten fasteners, securing the bottom jamb bracket in the vertical track assemblies / bottom slot in the wall angle to jamb, maintain 1/2" to 3/4" spacing, between the bottom section and vertical track.

Allow proper clearance as shown and use the values as illustrated in the Side Room Requirements (Minimum Distance Required), located in the pre-installation section of this manual.

Hang counterbalance lift cable over flag angle / wall angle. Repeat same process for other side.

12

## Stacking Sections

Tools Required: Power drill, 7/16" Socket driver, Safety glasses, Tape measure, Step ladder, Leather gloves

**NOTE:** Refer to door section identification, located in the pre-installation section of this manual.

**NOTE:** The sections can be identified by the graduation of the factory installed graduated end hinges. The smallest graduated end hinge on section should be stacked on top of the bottom section, with each graduated end hinge increasing as the sections are stacked, see Parts Breakdown.

**NOTE:** Make sure graduated end and center hinges are flipped down, when stacking another section on top.

With assistance, lift second (Lock) section and guide the track rollers into the vertical tracks. Lower section until it is seated against bottom section. Flip hinges up. Fasten center hinge(s) first; then graduated end hinges last using 1/4" - 20 x 7/8" self-drilling screws.

Repeat same process for other sections, except top section.

**IMPORTANT:** PUSH & HOLD THE UPPER HINGE LEAFS SECURELY AGAINST THE SECTIONS WHILE SECURING WITH 1/4" - 20 X 7/8" SELF-DRILLING SCREWS. THERE SHOULD BE NO GAP BETWEEN THE HINGE LEAFS AND THE SECTIONS.

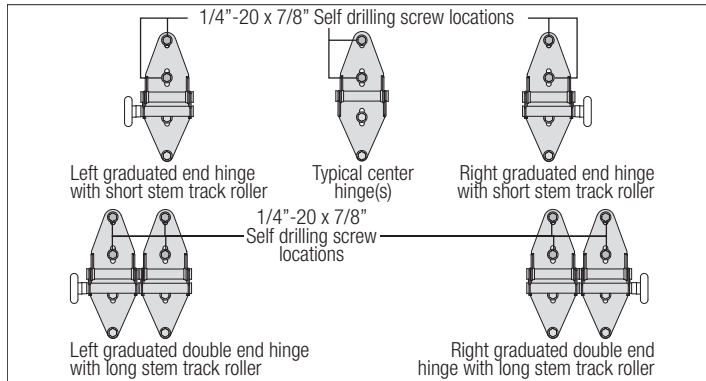
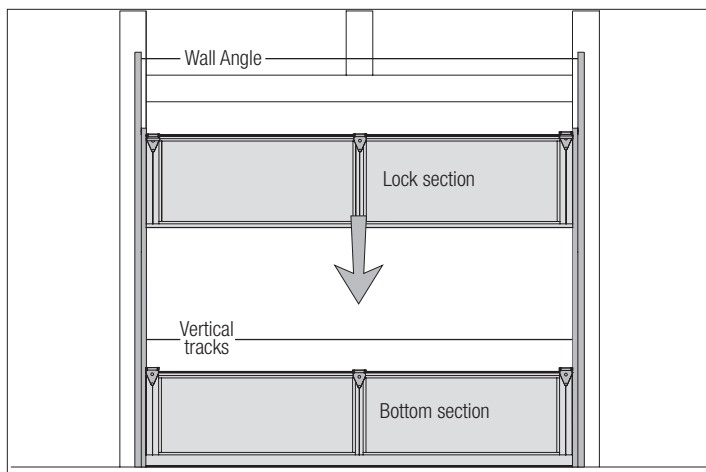

**13**

**Pull Handles**

Tools Required: Power drill, 9/32" Drill bit, 7/16" Socket driver, Safety glasses, Tape measure, Pencil, Leather gloves

On the inside of bottom section, locate the bottom horizontal rail. Using the illustrations below, position and center the pull handle on the bottom section, as shown.

**IMPORTANT:** THE PULL HANDLE(S) NEEDS TO BE HORIZONTALLY ALIGNED WITH THE BOTTOM SECTION RAIL.

Using the holes in the lift handle as a template, mark the hole locations onto the section surface. Drill 9/32" diameter holes straight through the entire section at each marked location.



Assemble the pull handle to the inside of bottom section using (2) 1/4" - 20 x 5/8" self drilling screws. Now using the pre-drilled holes, assemble the pull handle to the outside of bottom section using (2) 1/4" - 20 x 5/8" self drilling screws. If applicable, repeat the same process for other pull handles.

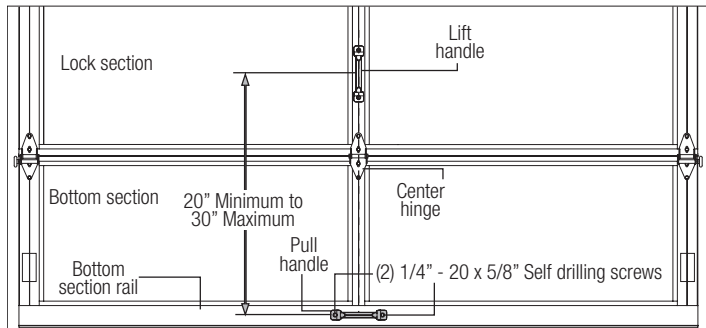

**14**

**Lift Handles**

Tools Required: Power drill, 9/32" Drill bit, 7/16" Socket driver, Safety glasses, Tape measure, Pencil, Leather gloves

On the inside of the lock (second) section, locate the vertical center stile. Using the illustrations below, position and center the lift handle on the lock (second) section, as shown.

**IMPORTANT:** THE LIFT HANDLE(S) NEEDS TO BE VERTICALLY ALIGNED WITH THE CENTER STILE.

**IMPORTANT:** THE DISTANCE BETWEEN THE PULL HANDLE(S) AND THE MIDDLE OF THE LIFT HANDLE(S) MUST BE 20" MINIMUM TO 30" MAXIMUM. IF NECESSARY, REPOSITION THE

UPPER LIFT HANDLE(S) TO STAY WITHIN THE REQUIRED DIMENSION.

Using the holes in the lift handle as a template, mark the hole locations onto the section surface. Drill 9/32" diameter holes straight through the entire section at each marked location.



Assemble the lift handle to the lock (second) section using (2) 1/4" - 20 x 5/8" self drilling screws. If applicable, repeat the same process for other lift handle. Now using the pre-drilled holes, assemble the lift handle to the outside of bottom section using (2) 1/4" - 20 x 5/8" self drilling screws. If applicable, repeat the same process for other lift handles.

**IMPORTANT:** THE LIFT HANDLE(S) AND THE PULL HANDLE(S) NEED TO BE VERTICALLY ALIGNED.

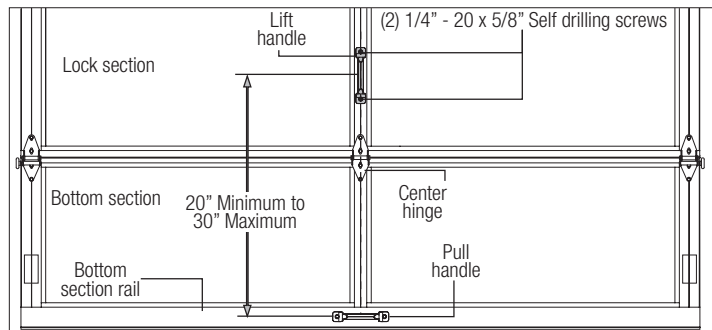

**15**

**Top Section**

Tools Required: Power drill, 7/16" Socket driver, 7/16" Wrench, Step ladder, Tape measure, Safety glasses, Leather gloves

Place the top section in the opening. Temporarily secure the top section by driving a nail into the header near the center of the door and bending it over the top section.

**NOTE:** Instead of using a nail(s) to temporarily secure the top section, you can use flat tip screwdriver(s) near the center of the door and angle it down and over the top section.

Now, flip up the graduated end and center hinge leaves, hold tight against section, and fasten center hinges first and graduated end hinges last (refer to step, Stacking Sections).

Vertical track alignment is critical. Position wall angle from the edge of the door:

**FOR 2" TRACK APPLICATIONS:** 1-11/16" (43 mm) to 1-3/4" (44 mm) for smooth, safe door operation.

**FOR 3" TRACK APPLICATIONS:** 2-3/16" (56 mm) to 2-1/4" (57 mm) for smooth, safe door operation

Tighten the bottom lag screw. Flag angles / wall angles must be parallel to the door sections. Repeat same process for other side.

**FOR 2" TRACK APPLICATIONS:** Door width plus 3-3/8" (86mm) to 3-1/2" (89 mm) for smooth, safe door operation.

**FOR 3" TRACK APPLICATIONS:** Door width plus 4-7/8" (124mm) to 5" (127 mm) for smooth, safe door operation.

Complete the vertical track installation by securing the fasteners to the jamb. Push the vertical track against the track rollers so that the track rollers are touching the deepest part of the curved side of the track; tighten all the track bolts and nuts. Repeat for other side.

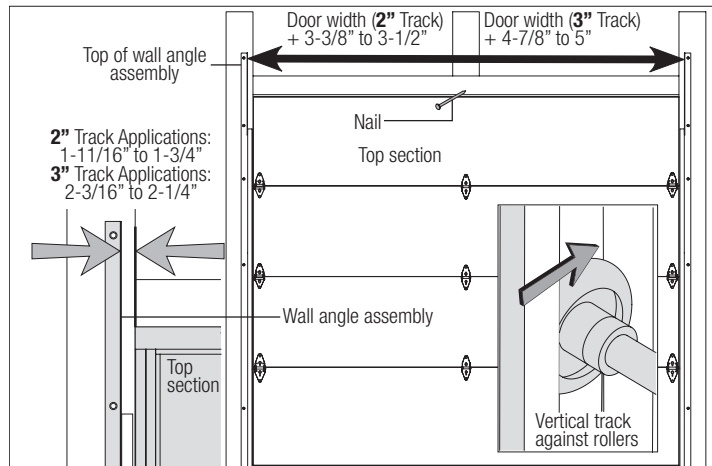

16

## Horizontal Tracks

Tools Required: Ratchet wrench, 9/16" 7/16" Socket, 9/16" 7/16" Wrench, Step ladder, Tape measure, Safety glasses, Leather gloves

**NOTE:** Depending on your door, you may have Fully Adjustable Flag Angles, Riveted Vertical Track Assemblies or you may have Angle Mount Vertical Track Assemblies. Refer to Package Contents / Parts Breakdown, to determine which Flag Angles / Vertical Track Assemblies you have.

### WARNING

**DO NOT RAISE DOOR UNTIL HORIZONTAL TRACKS ARE SECURED AT REAR, AS OUTLINED IN STEP, REAR BACK HANGS, OR DOOR COULD FALL FROM OVERHEAD POSITION CAUSING SEVERE OR FATAL INJURY.**

**IMPORTANT:** Prior to installing the horizontal tracks, use cables or chains to temporarily suspend the rear portion of horizontal tracks.

### WARNING

**DO NOT USE ROPES, SINCE EDGES OF HORIZONTAL TRACKS AND ANGLES ARE VERY SHARP.**

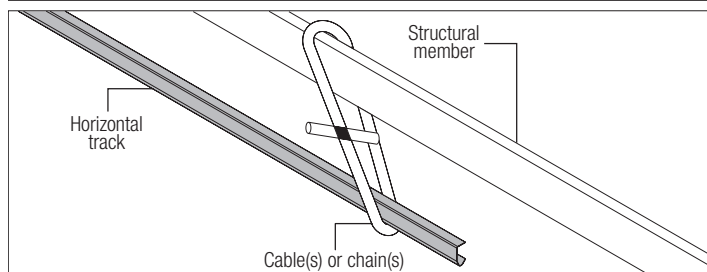

**IF YOU HAVE FULLY ADJUSTABLE FLAG ANGLES:** To install horizontal track, place the curved end over the top track roller of the top section. Align the bottom of the horizontal track with the top of the vertical track. Tighten the horizontal track to the flag angle with (2) 1/4" - 20 x 9/16" track bolts and (2) 1/4" - 20 flange hex nuts.

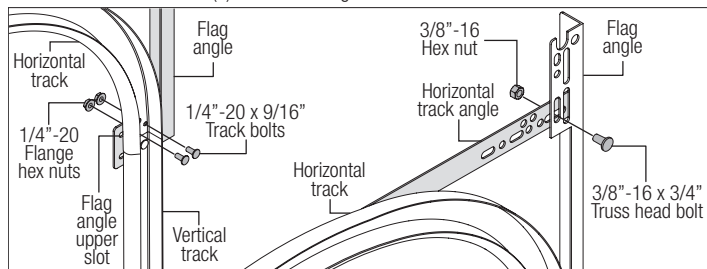

**IF YOU HAVE RIVETED TRACK ASSEMBLIES OR ANGLE MOUNT VERTICAL TRACK ASSEMBLIES:** To install horizontal track, place the curved end over the top roller of the top section. Align the bottom of the horizontal track with the top of the vertical track. Tighten the horizontal track to the Flag Angle / Angle Mount with (2) 1/4" - 20 x 9/16" track bolts and (2) 1/4" - 20 flange hex nuts.

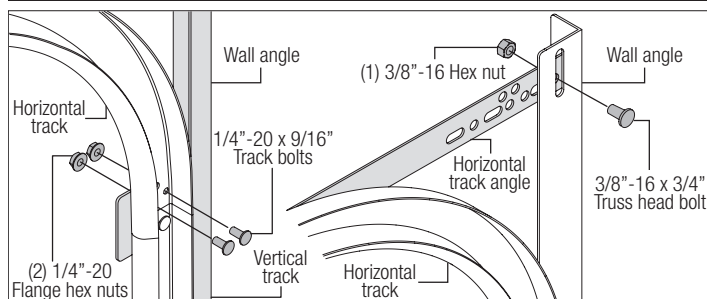
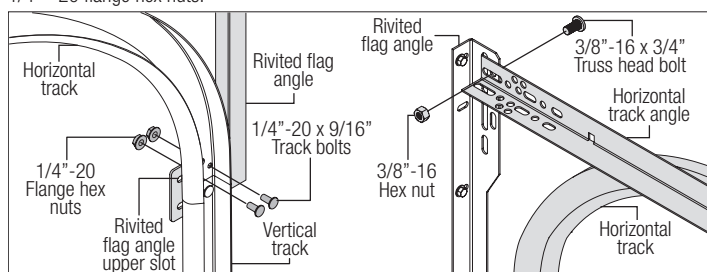

Next level the horizontal track assembly and bolt the horizontal track angle to the first en-

countered slot in the flag angle / angle mount using (1) 3/8" - 16 x 3/4" truss head bolt and (1) 3/8" - 16 hex nut. Repeat for other side.

17

## Adjusting Top Fixtures

Tools Required: 1/2" Wrench, Step ladder, Safety glasses, Leather gloves

With horizontal tracks installed, you can now adjust the top fixtures. Vertically align the top section of the door with the lower sections. Once aligned, position the top fixture slide, out against the horizontal track. Maintaining the slide's position, tighten the 5/16" - 18 hex nuts to secure the top fixture slide to the top fixture base. Repeat for other side.

Next remove the nail(s) that was temporarily holding the top section in place, installed in step, Top Section.

**IMPORTANT:** FAILURE TO REMOVE NAIL(S) BEFORE ATTEMPTING TO RAISE DOOR COULD CAUSE PERMANENT DAMAGE TO TOP SECTION.

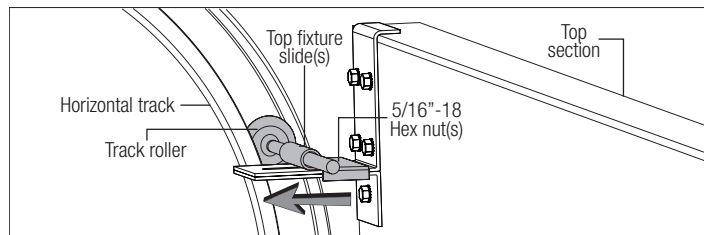

18

## End Bearing Brackets

Tools Required: Power drill, Ratchet wrench, 3/16" Drill bit, 7/16" Socket driver, 9/16" Socket, 9/16" Wrench, Safety glasses, Step ladder, Leather gloves

### WARNING

**INSTALL END BEARING BRACKETS TO SOLID STRUCTURAL MEMBERS ONLY. DO NOT INSTALL OVER DRY WALL OR PANELING. FAILURE TO INSTALL END BEARING BRACKETS TO SOLID STRUCTURAL MEMBERS CAN CAUSE SEVERE OR FATAL INJURY.**

### WARNING

**FAILURE TO USE PROPER NUMBER OF FASTENERS CAN RESULT IN SUDDEN SPRING TENSION RELEASE, CAUSING SEVERE OR FATAL INJURY.**

**NOTE:** Spring pads must be securely anchored before proceeding, as shown. The pads must be flush with the jambs

**IMPORTANT:** RIGHT AND LEFT HAND IS ALWAYS DETERMINED FROM INSIDE THE BUILDING LOOKING OUT.

**NOTE:** End bearing brackets are right hand and left hand.

Attach the left hand end bearing bracket through either the end bearing bracket's upper or lower slots to the left hand horizontal track angle using (2) 3/8" - 16 x 3/4" truss head bolts and (2) 3/8" - 16 nuts.

**IMPORTANT:** THE END BEARING BRACKET'S LOWER SLOTS ARE USED ON DOORS WITH 12" RADIUS TRACK; THE UPPER SLOTS ARE USED ON DOORS WITH 15" RADIUS TRACK.

**SECURE THE END BEARING BRACKET TO THE JAMB USING ONE OF THE FOLLOWING SCENARIOS LISTED BELOW:**

Wood jambs, using (3) 5/16" x 1-5/8" lag screws. Drill (3) 3/16" pilot holes into the wood jamb for the lag screws.

Steel jambs, using (3) 5/16" x 1" self drilling screws.

Pre-cast concrete, using (3) 3/8" x 3" sleeve anchors (not supplied).

**NOTE:** Products being installed to pre-cast or block must use a 3/8" x 3" sleeve anchor to attach the wall angle to the building, as shown. Use the slots in the wall angle as a drill template and drill a 3/8" hole (3-1/2" deep) and secure to anchor.

### WARNING

**DO NOT USE SLEEVE ANCHORS ON HOLLOW BLOCK.**

Repeat the same process for the right hand side.

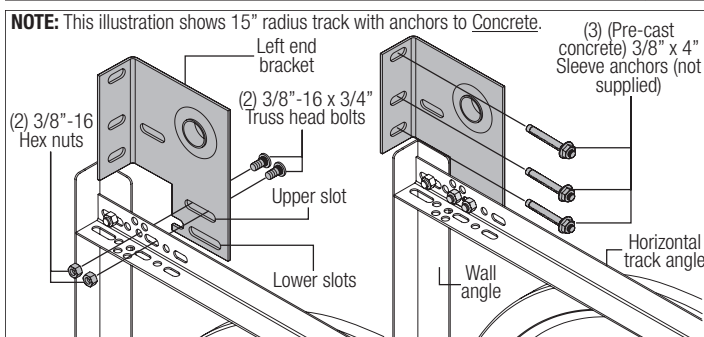
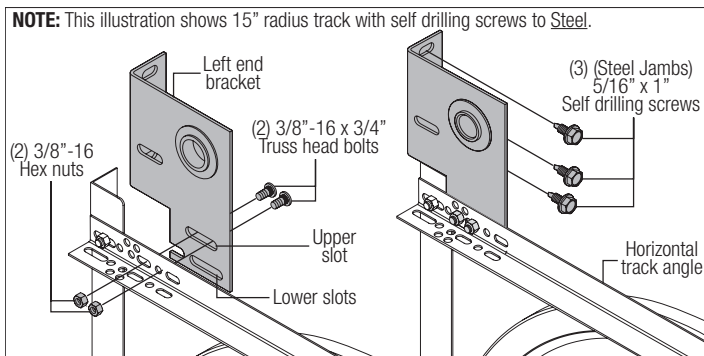
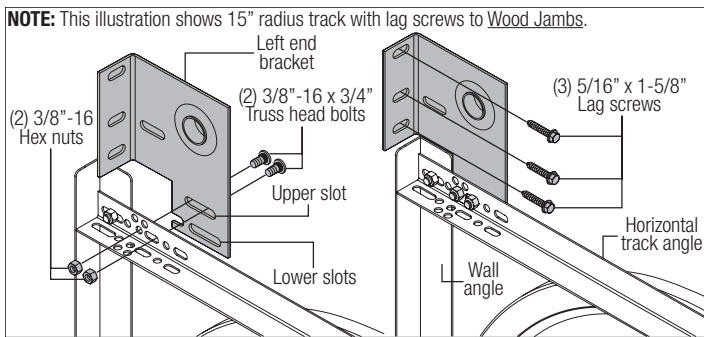

**BLOCK CONSTRUCTION:** Attach perforated angle 18" long to center bracket(s) using (2) 3/8" x 1-1/4" bolts and (2) 3/8" nuts. Chamfer angle to clear top section high arc. Secure center bracket(s) and perforated angle to block using (4) 3/8" x 2-1/2" sleeve anchors, as shown.

**WARNING**  
DO NOT USE SLEEVE ANCHORS ON HOLLOW BLOCK.

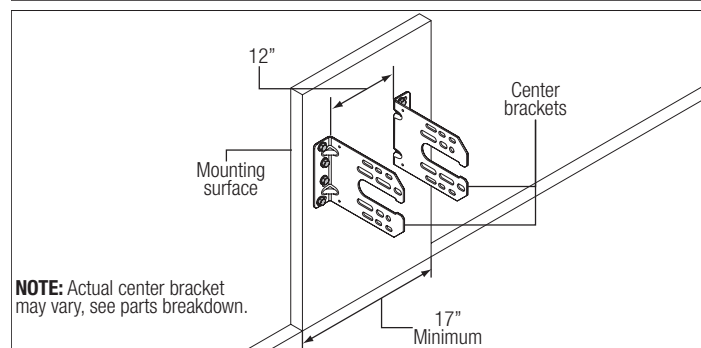
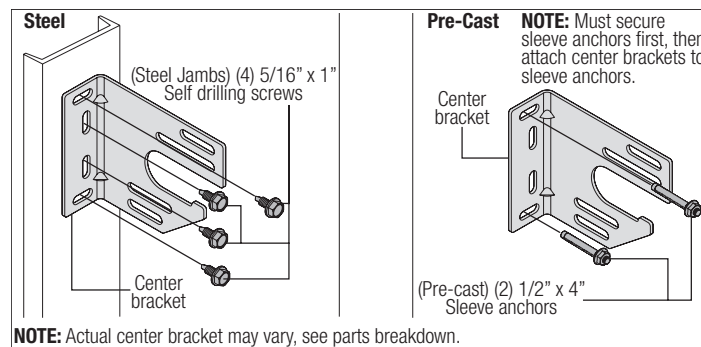
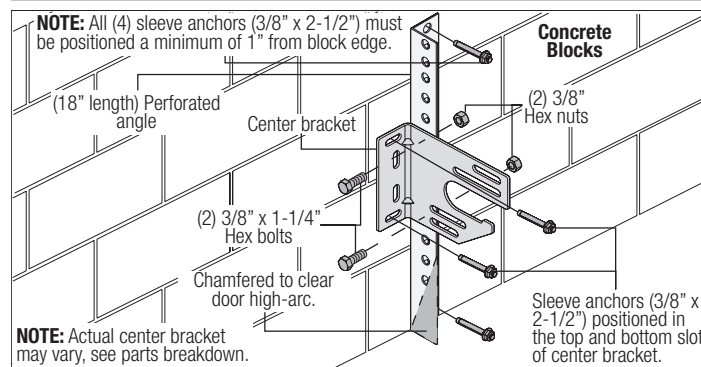
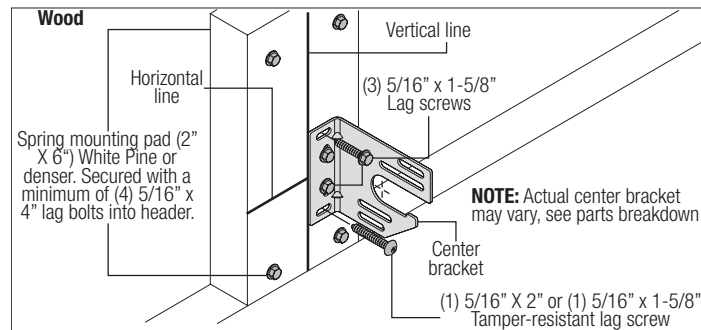

**ALTERNATE STEEL SPRING PAD APPLICATIONS:**  
**IMPORTANT:** DO NOT BOLT TWO 3-3/4" OR LARGER DIAMETER SPRINGS TO ONE CENTER BRACKET.

**WARNING**  
THESE SPRING MOUNTING TECHNIQUES ARE NOT SUPPORTED FOR 800-32 CABLE DRUMS. THESE INSTRUCTIONS ARE ALSO NOT APPLICABLE FOR 5750-120 CABLE DRUMS WITH 72" OR MORE HIGH-LIFT.

19

**Center Bracket(s)**

Tools Required: Power drill, 3/16" Drill bit, 7/16" Socket driver, 1/4" Torx bit, Level, Tape measure, Pencil, Safety glasses, Leather gloves

**NOTE:** When attaching the center bracket(s) to the spring pads, it has to be at the same elevation as the bearing in the end bearing brackets.

**NOTE:** Additional center brackets may be required for doors with coupler assembly. Refer to Package Contents / Parts Breakdown, to determine if you have a coupler assembly.

**NOTE:** If your door came with (4) or more springs, each of the outer springs mounting surface will need to be a minimum of 3" wide.

**NOTE:** If needed, measure the diameter of your springs. If you have a one piece shaft with 3-3/4" or larger diameter springs, they do not share center brackets and do not have a coupler assembly.

Locate the center of the door. Mark a vertical pencil line on the mounting surface above the door, at the center. Measure from the center of the bearing, in one of the end bearing brackets, downwards, to the top the door. Using that measurement, measure that distance upwards from the top of the door to the mounting surface and mark a horizontal pencil line which intersects the vertical pencil line.

**WOOD:** Align the edge of the center bracket with the vertical pencil line and the center of the center bracket with the horizontal pencil line; this is to ensure the torsion shaft is level between the center and end bearing brackets. Attach the center bracket to the mounting surface, using 5/16" x 1-5/8" lag screws and (1) 5/16" x 2" tamper-resistant lag screw.

**NOTE:** Pre-Drill 3/16" pilot holes into the wood jamb for the lag screws.

**IMPORTANT:** USE A 5/16" X 1-5/8" TAMPER-RESISTANT LAG SCREW INSTEAD OF THE 5/16" X 2" TAMPER-RESISTANT LAG SCREW IF MOUNTING SURFACE IS MOUNTED OVER MASONRY. TAMPER-RESISTANT LAG SCREW MUST BE ATTACHED THROUGH THE BOTTOM HOLE OF THE CENTER BRACKET.

**NOTE:** Depending on the construction, different fasteners must be used.

**STEEL:** Secure each center bracket using (4) 5/16" x 1" self-drilling and tapping screws, as shown.

**PRE-CAST:** Secure each center bracket using (2) 1/2" x 3" sleeve anchors (by others). This installation will require the 1/2" anchors to be secured to the building, then secure the brackets to the anchors, as shown.

**NOTE:** Pre-Drill 1/2" pilot holes into the Pre-Cast for the 1/2" x 3" sleeve anchors.

# WARNING

**MAXIMUM SPACING FOR DIMENSION "Y" IS 84" (7 FT.) THESE INSTRUCTIONS ARE NOT APPLICABLE FOR A SPAN GREATER THAN 84".**

## Maximum Door Size 9'0" x 9'0" (Maximum Door Weight 210 lb.)

Cut perforated angle (1-5/8" x 2-3/8" x 11 GA.) to Dim "Y". Thru-bolt top and bottom of angle to each girt using (4) 3/8" x 1-1/4" bolts and (4) 3/8" nuts. Thru-bolt center bracket to perforated angle using (3) 3/8" x 1-1/4" bolts and (3) 3/8" nuts, as shown.

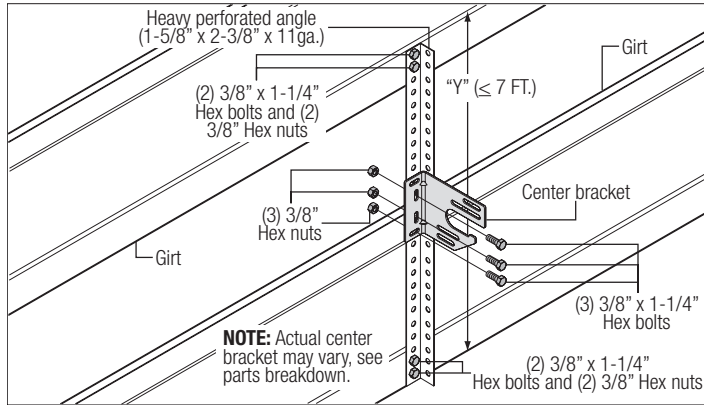

## Maximum Door Size 14'0" x 12'0" (Maximum Door Weight 400 lb.)

Cut (2) perforated angle (1-5/8" x 2-3/8" x 11 GA.) to Dim "Y". Thru-bolt top and bottom of each angle to each girt using (4) 3/8" x 1-1/4" bolts and (4) 3/8" nuts. Thru-bolt each center bracket to perforated angle using (3) 3/8" x 1-1/4" bolts and (3) 3/8" nuts, as shown.

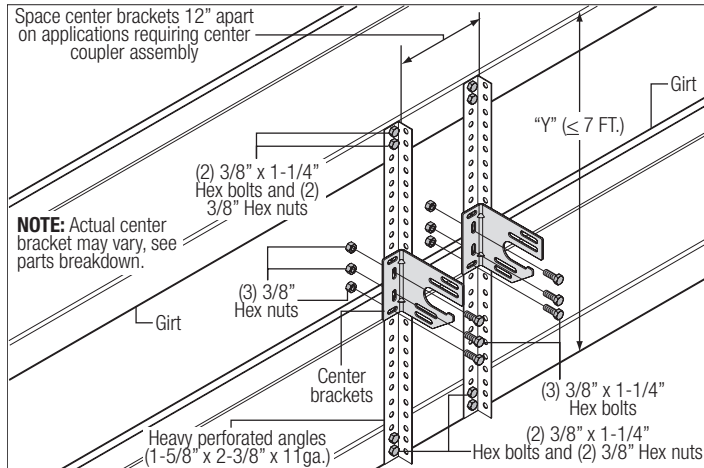

## Maximum Door Size 14'-2" x 12'-1" (Maximum Door Weight 800 lb.)

Cut (2) pieces of perforated angle (1-5/8" x 2-3/8" x 11 GA.) to Dim "Y" and (2) more pieces at Dim "Y" minus 3". Bolt the angles together into a "Z" shape using (4) 3/8" x 1-1/4" bolts and (4) 3/8" nuts. Thru-bolt top and bottom of each "Z" shaped angle to each girt using (4) 3/8" x 1-1/4" bolts and (4) 3/8" nuts. Thru-bolt each center bracket to perforated angle assembly using (3) 3/8" x 1-1/4" bolts and (3) 3/8" nuts, as shown.

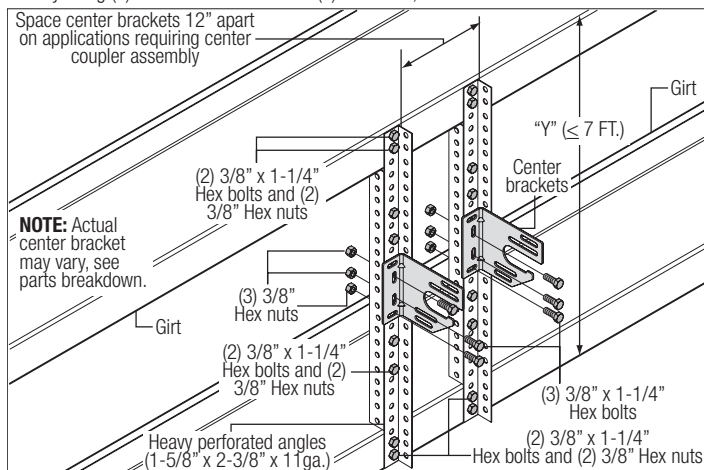

# 20

## Torsion Spring Assembly

Tools Required: Step Ladder, Safety glasses, Leather gloves

**IMPORTANT:** RIGHT AND LEFT HAND IS ALWAYS DETERMINED FROM INSIDE THE BUILDING LOOKING OUT.

**NOTE:** Torsion spring assemblies can be of several configurations depending on your door size and door weight.

**IMPORTANT:** ON SINGLE SPRING APPLICATIONS, ONLY A LEFT HAND WOUND (BLACK WINDING CONE), WHICH GOES ON THE RIGHT HAND SIDE IS REQUIRED.

**NOTE:** Identify the torsion springs provided as either right hand wound (red winding cone), which goes on the LEFT HAND SIDE or left hand wound (black winding cone), which goes on the RIGHT HAND SIDE.

Facing the inside of the door and referencing the illustrations shown, lay the torsion shaft / torsion keyed shaft(s) on the floor.

**NOTE:** If your door came with (2) torsion keyed shafts, one torsion keyed shaft should be on the left hand side of the floor and the other torsion keyed shaft should be on the right hand side of the floor.

Lay the torsion spring(s) with the black winding cone and the black cable drum at the right end of the torsion shaft / torsion keyed shaft(s). Lay the torsion spring(s) with the red winding cone and the red cable drum at the left end of the torsion shaft / torsion keyed shaft(s).

**NOTE:** The set screws used on all torsion winding cones and cable drums are colored red. DO NOT identify right and left hand by the set screw color.

**IF YOUR DOOR CAME WITH A COUPLER ASSEMBLY:** Disassemble the coupler assembly by removing the (3) 3/8" - 16 x 1-3/4" hex head screws and the (3) 3/8" - 16 nylon hex lock nuts from the coupler halves. Loosen the set screws. Slide the flat edge of the coupler half flush with the side edge of the torsion keyed shaft. Insert (1) key into the slot of both the coupler halves and the slot in the torsion keyed shaft. Tighten the (2) set screws and the locking nut to secure the coupler half to the torsion keyed shaft, as shown. Repeat the same processes for the other coupler half.

**NOTE:** Tighten the set screws to 14 - 15 ft. lbs. of torque (once set screws contact the shaft, tighten set screws one full turn).

**IMPORTANT:** THE COUPLER HALVES, CENTER BEARING(S), TORSION SPRINGS, AND CABLE DRUMS MUST BE POSITIONED, AS SHOWN IN THE ILLUSTRATIONS.

### Single Spring Or Double Springs Applications, 1 Piece Shaft, Up To 2-5/8" Springs

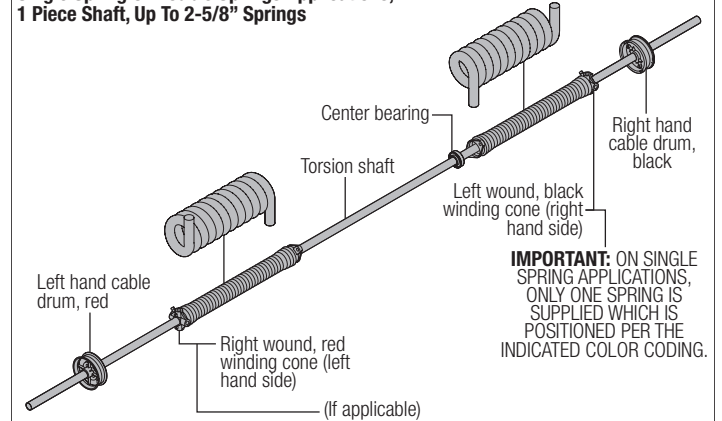

### Double Springs Applications, Two Or Four Springs, 1 Piece Shaft, Up To 2-5/8" Springs

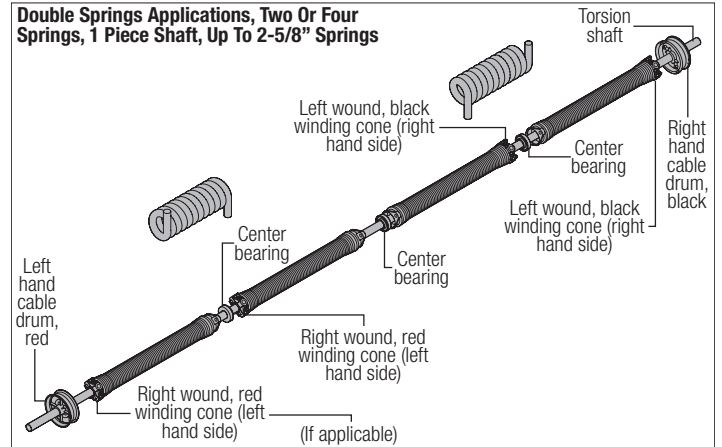

### Single Spring Or Double Springs Applications, 1 Piece Shaft, 3-3/4" and 6" Springs

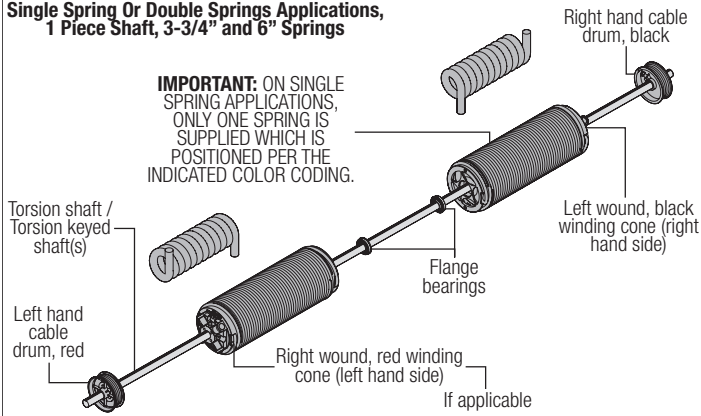

### Double Springs Applications, 2 Piece Shafts, Two or 4 springs, up to 6" Springs.

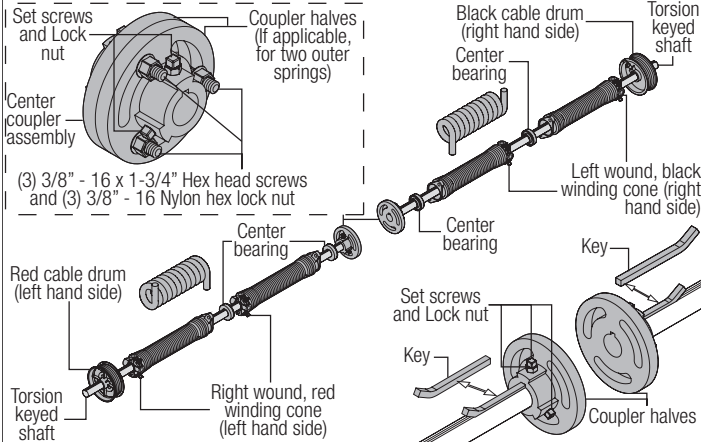

**IF YOUR DOOR DOESN'T HAVE A COUPLER ASSEMBLY:** With assistance, pick up the torsion spring assembly and slide one end of the torsion shaft / torsion keyed shaft through one end bearing bracket. Lay the middle of the torsion shaft / torsion keyed shaft into the center bracket. Slide the other end of the torsion shaft / torsion keyed shaft into the other end bearing bracket. Position the torsion shaft / torsion keyed shaft so that equal amounts of the shaft extend from each of the end bearing brackets.

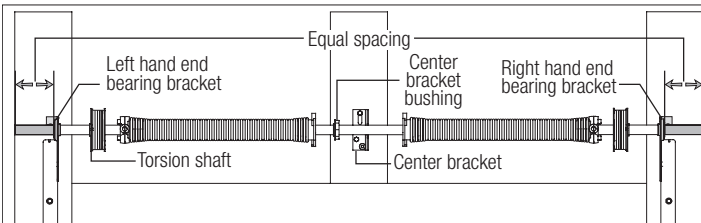

**IF YOUR DOOR HAS A COUPLER ASSEMBLY:** With assistance and starting on the left hand side of door, pick up the left hand torsion spring assembly and slide one end of the torsion keyed shaft through the end bearing bracket. Lay the other side of the torsion keyed shaft into the center bracket. Repeat the same process for the right hand torsion spring assembly. Position both torsion keyed shafts so that equal amounts of the shafts extend from each of the end bearing brackets.

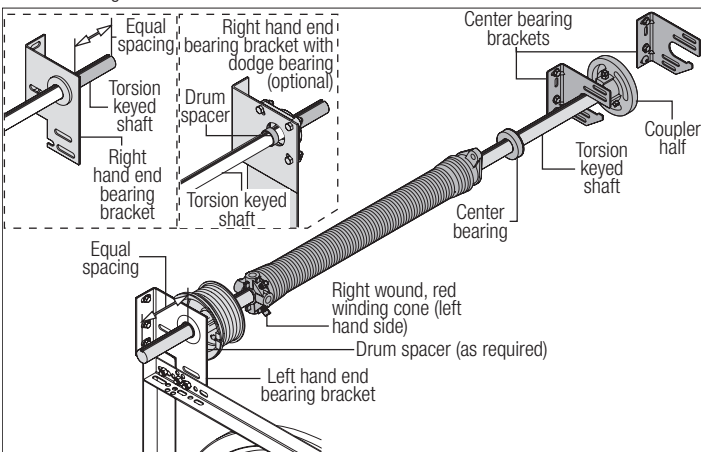

## 21

### Torsion Spring Attachment

Tools Required: Step Ladder, Ratchet Wrench, 9/16" Socket, 9/16" Wrench, Safety glasses, Leather gloves

**FOR SPRINGS UP TO 3-3/4" ID AND IF YOU DON'T HAVE A COUPLER ASSEMBLY:** Slide center bearing into the spring (if applicable). Align the stationary spring cone(s) with the holes in the center bracket assembly. Secure the torsion spring(s) to the center bracket assembly with (2) 3/8" - 16 x 1-1/2" hex head bolts and (2) 3/8" - 16 nuts.

**IMPORTANT:** THE SPRING WARNING TAG (S) SUPPLIED MUST BE SECURELY ATTACHED TO THE STATIONARY SPRING CONE(S) IN PLAIN VIEW. SHOULD A REPLACEMENT SPRING WARNING TAG BE REQUIRED, CONTACT WAYNE DALTON FOR REPLACEMENT.

**IF YOU HAVE A COUPLER ASSEMBLY:** Slide the center bearing into the spring. Align the stationary spring cone with the holes in the center bearing bracket.

**NOTE:** Prior to attaching the torsion spring(s) to the center bracket(s), the torsion shaft / torsion keyed shafts have to be at the same elevation as the bearing in the end bearing brackets. Slide the torsion shaft / torsion keyed shafts out to the correct shaft centerline from the jambs before tightening the spring assembly fasteners.

**FOR SPRINGS UP TO 3-3/4" ID:** Secure the torsion spring to the center bracket with (2) 3/8" - 16 x 1-1/2" hex head bolts and (2) 3/8" - 16 nuts. Repeat the same process for the other center bearing bracket.

**FOR 6" AND DUPLEX SPRINGS:** Secure the torsion spring and the flange bearing to the center bracket using (2) 3/8" - 16 x 1" Hex head bolts, as shown.

## WARNING

**FOR DUPLEX SPRINGS, YOU MUST ENSURE THE ASSEMBLY BOLTS GO THROUGH THE CENTER BRACKET AND INNER SPRING CONE AND THREAD INTO THE OUTER SPRING CONE AS SHOWN. FAILURE TO ENSURE THE BOLTS ARE SECURING BOTH THE INNER AND OUTER SPRING CONES TO THE CENTER BRACKET CAN RESULT IN SUDDEN SPRING TENSION RELEASE, CAUSING SEVERE OR FATAL INJURY.**

At the middle of the two center bearing brackets, loosely re-assemble the coupler assembly by fastening the coupler halves together using the (3) 3/8" - 16 x 1-3/4" hex head screws and the (3) 3/8" - 16 nylon hex lock nuts, as shown.

**NOTE:** Ensure both torsion keyed shafts have equal amounts of the shafts extending from each end bearing brackets.

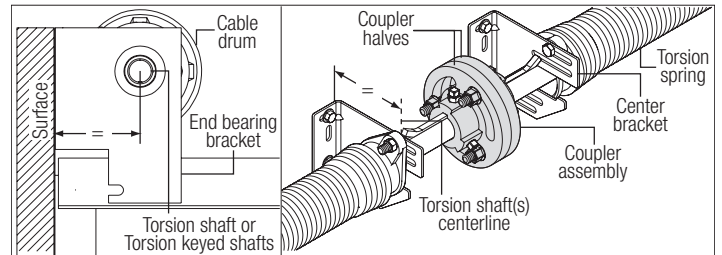

### Up To 3-3/4" Springs Applications

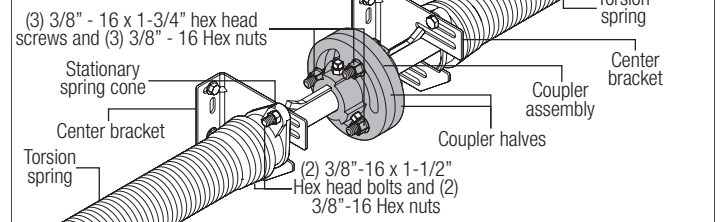

### 6" Springs Applications

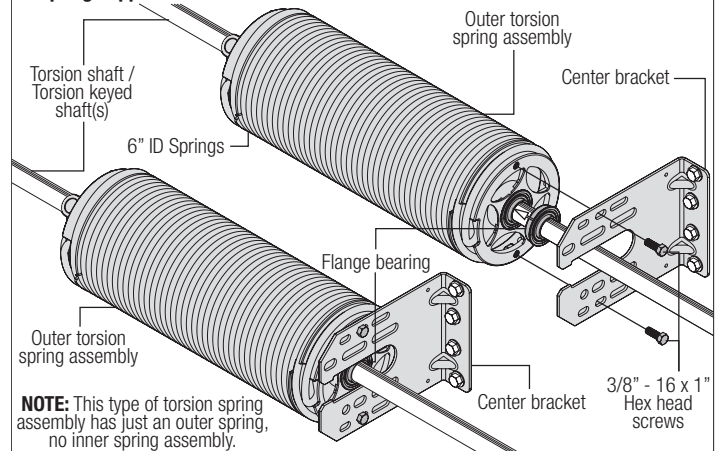



## 6" Duplex Springs Applications

**NOTE:** Prior to securing the center bracket to the torsion spring, ensure The bolt goes through the inner spring cone and threads into the outer spring cone.

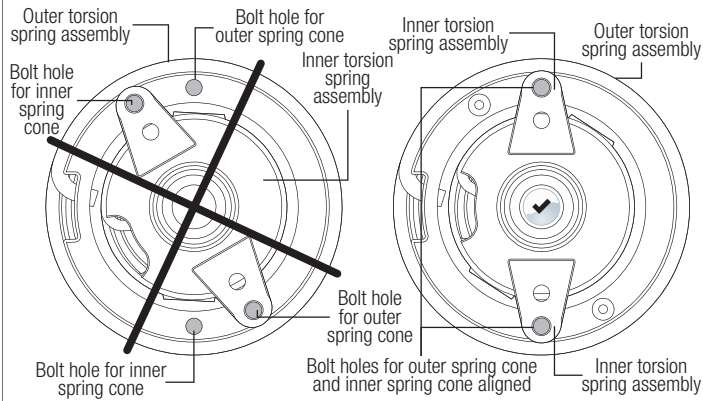

## 6" Duplex Springs Applications

**NOTE:** This type of torsion spring assembly has both an outer spring and an inner spring assembly.

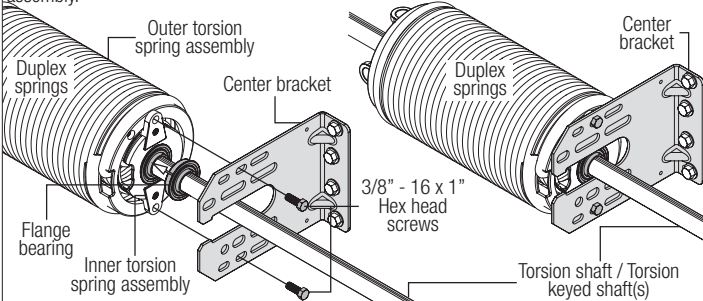

## 22 Counterbalance Lift Cables

Tools Required: Step Ladder, Locking Pliers, 3/8" Wrench, Safety glasses, Leather gloves

Starting on the left hand side, thread the counterbalance lift cable up and around the front side of the left hand cable drum.

**IMPORTANT:** VERIFY THAT THERE ARE NO COUNTERBALANCE LIFT CABLE OBSTRUCTIONS.

Hook the counterbalance lift cable into the left hand cable drum. Slide the left hand cable drum up against the left hand end bearing bracket / spacer. Counterbalance lift cable should terminate at the 3 o'clock position.

**NOTE:** If you have torsion keyed shaft(s), insert (1) key into the slot of both the cable drum and the slot in the torsion keyed shaft, as shown.

**FOR SPRINGS UP TO 3-3/4" ID:** Tighten the (2) set screws in the drum to 14 - 15 ft. lbs. of torque (once set screws contact the shaft, tighten screws one full turn).

**FOR 6" AND DUPLEX SPRINGS:** Tighten the (4) set screws in the drum to 25 ft. lbs. of torque (once set screws contact the shaft, tighten screws 1/2 to 1 full turn).

At the middle of the two center bearing brackets, loosen the (3) 3/8" - 16 x 1-3/4" hex head screws and the (3) 3/8" - 16 nylon hex lock nuts from the coupler assembly (if applicable).

Rotate the left hand drum and torsion shaft until counterbalance lift cable is taut. Now attach locking pliers to the torsion shaft and brace locking pliers up against jamb to keep counterbalance lift cable taut. Repeat for right hand side.

At the middle of the two center bearing brackets, tighten the (3) 3/8" - 16 x 1-3/4" hex head screws and the (3) 3/8" - 16 nylon hex lock nuts from the coupler assembly (if applicable).

**IMPORTANT:** INSPECT EACH COUNTERBALANCE LIFT CABLES MAKING SURE THEY ARE SEATED PROPERLY ONTO THE CABLE DRUMS AND THAT BOTH COUNTERBALANCE LIFT CABLES HAVE EQUAL TENSION.

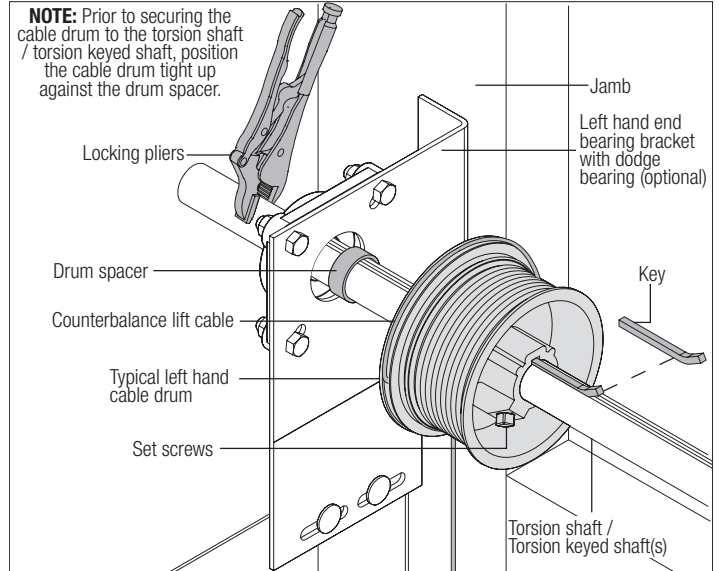
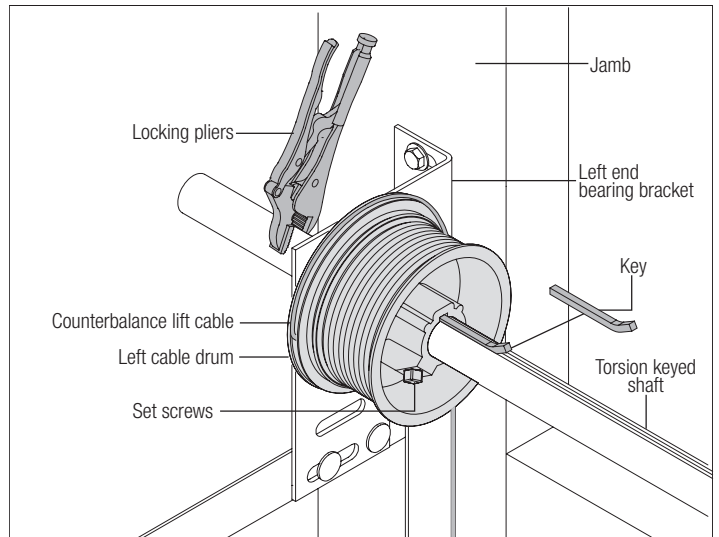
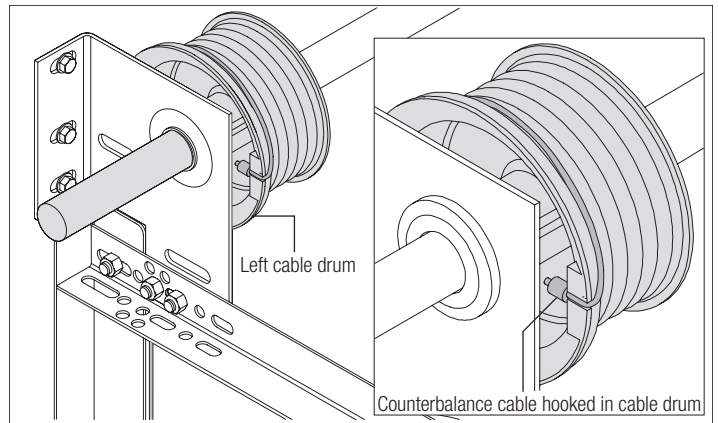

**NOTE:** Prior to securing the cable drum to the torsion shaft / torsion keyed shaft, position the cable drum tight up against the drum spacer.

## 23 Chalking Torsion Spring(s)

Tools Required: Step ladder, Chalk, Safety glasses, Leather gloves

Draw a chalk line horizontally along the center of the torsion spring coil(s). As the torsion spring is wound, the chalk line will create a spiral. This spiral can be used to count and determine the number of turns that are applied on the torsion spring.

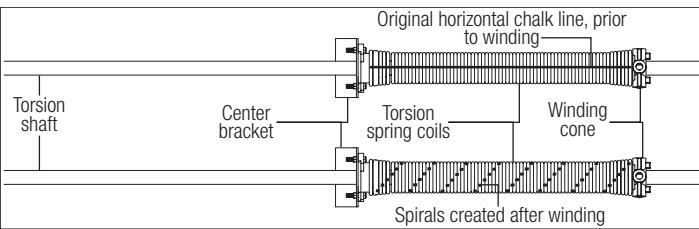

24

### Securing Door for Spring Winding

Tools Required: Vice clamps, Safety glasses

With the door in the fully closed position, place vice clamps / c-clamps onto both vertical tracks just above the third track roller. This is to prevent the garage door from rising while winding springs.

**NOTE:** Check the following before attempting to wind torsion spring(s):

- Counterbalance lift cables are secured at bottom corner brackets.
- Counterbalance lift cables are routed unobstructed to cable drums.
- Counterbalance lift cables are correctly installed and wound onto cable lift drums.
- Counterbalance lift cables are taut and have equal tension on both sides.
- Cable lift drums are against end bearing brackets and set screws are tight.
- Torsion spring or springs are installed correctly.
- Review the label attached to the spring warning tag, to determine number of spring turns required.

**NOTE:** Door **MUST** be closed and locked when winding or making any adjustments to the torsion spring(s).

### WARNING

**FAILURE TO ENSURE DOOR IS IN A CLOSED POSITION AND TO PLACE VICE CLAMP ONTO VERTICAL TRACK CAN ALLOW DOOR TO RAISE AND CAUSE SEVERE OR FATAL INJURY.**

Winding Bars (Steel Rods)	Size Of Winding Bar (Inches)	Spring Diameter Used On
—	1/2" dia. x 18"	2" and 2-5/8"
	5/8" dia. x 24"	3-3/4" and 6"

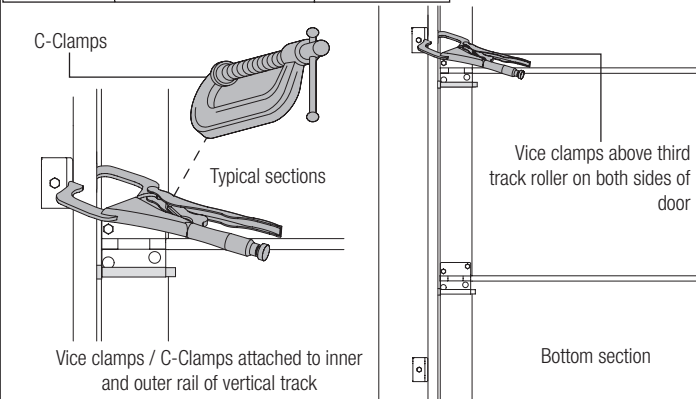

25

### Winding Spring(s)

Tools Required: Step Ladder, Approved winding bars, 3/8" Wrench, Leather gloves, Safety glasses

### WARNING

**WINDING TORSION SPRING(S) IS AN EXTREMELY DANGEROUS PROCEDURE AND SHOULD BE PERFORMED ONLY BY A TRAINED DOOR SYSTEM TECHNICIAN USING PROPER TOOLS AND INSTRUCTIONS.**

### WARNING

**USE ONLY SPECIFIED WINDING BARS, AS STATED IN STEP SECURING DOOR FOR SPRING WINDING. DO NOT SUBSTITUTE WITH SCREWDRIVERS, PIPE, ETC. OTHER TOOLS MAY FAIL OR RELEASE FROM THE SPRING CONE AND CAUSE SERIOUS PERSONAL INJURY.**

### WARNING

**PRIOR TO WINDING OR MAKING ADJUSTMENTS TO THE SPRINGS, ENSURE YOU'RE WINDING IN THE PROPER DIRECTION AS STATED IN THE INSTALLATION INSTRUCTIONS. OTHERWISE THE SPRING FITTINGS MAY RELEASE FROM SPRING IF NOT WOUND IN THE PROPER DIRECTION AND COULD RESULT IN SEVERE OR FATAL INJURY.**

Position a ladder slightly to the side of the spring so that the winding cone is easily accessible, and so your body is not directly in line with the winding bars.

Check the label attached to the spring warning tag for the required number of complete turns to balance your door.

Alternately inserting the winding rods into the holes of the springs winding cone, rotate the winding cone upward toward the ceiling, 1/4 turn at a time, until the required number of complete turns for your door height is achieved.

**AS THE LAST 1/8 TO 1/4 TURN IS ACHIEVED:**

**FOR SPRINGS UP TO 3-3/4" ID:** Securely hold the winding rod while tightening the 2 set screws in the winding cone to 14 - 15 ft. lbs. of torque (once set screws contact the torsion shaft, tighten screws one full turn).

Torsion spring(s) should be wound in the direction the end coil points.

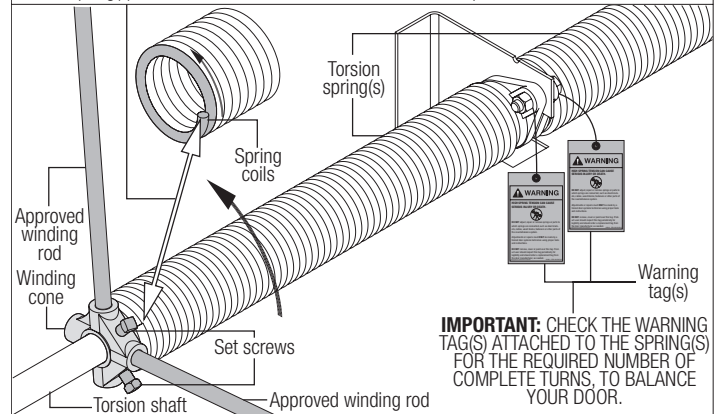

**FOR 6" AND DUPLEX SPRINGS:** Securely hold the winding rod while tightening the 4 set screws in the winding cone to 25 ft. lbs. of torque (once set screws contact the torsion keyed shaft, tighten screws 1/2 to 1 full turn).

**IMPORTANT:** IF YOU HAVE TORSION KEYED SHAFT(S), ONE OF THE SET SCREWS WILL NEED TO BE TIGHTENED INTO THE KEYWAY OF THE TORSION KEYED SHAFT(S).

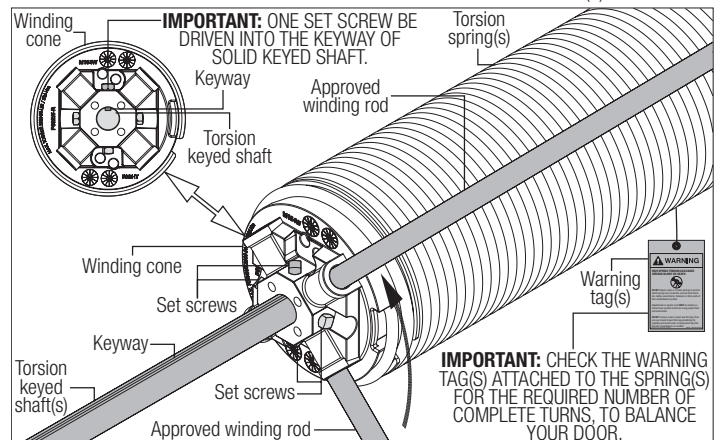

After the torsion spring is secure, use the winding rod to apply pressure in the opposite direction to ensure the set screws are securely fixed to the torsion shaft.

Carefully remove winding rod from winding cone. Repeat for remaining springs, if applicable. While holding the door down to prevent it from rising unexpectedly in the event the spring(s) were over-wound, carefully remove the locking pliers from the torsion shaft and vertical tracks.

**NOTE:** If you have a coupler assembly, it may be necessary to loosen and retighten the (3) 3/8" - 16 x 1-3/4" hex head screws and the (3) 3/8" - 16 nylon hex lock nuts assembly bolts to equalize the cable tension on both sides of the door.

Adjustments to the number of turns stated may be necessary. If door rises off floor under spring tension alone, reduce spring tension until door rests on the floor. If the door is hard to rise or drifts down on its own, add spring tension.

**NOTE:** An unbalanced door such as this can cause garage door opener operation problems.

## ⚠ WARNING

**DO NOT OPEN DOOR UNTIL STEP REAR BACK HANGS IS COMPLETED.**

26

### Rear Back Hangs

Tools Required: Ratchet wrench, Socket: 1/2" 5/8", Wrench: 1/2" 5/8", (2) Vice clamps, Tape measure, Level, Step Ladder, Safety glasses, Leather gloves

**IMPORTANT:** HOLD THE DOOR DOWN TO PREVENT IT FROM RISING UNEXPECTEDLY IN THE EVENT THE SPRING(S) WAS OVER-WOUND AND CAUTIOUSLY REMOVE VICE CLAMPS FROM VERTICAL TRACKS.

Raise the door until the top section and half of the next section are in the horizontal track radius. Do not raise door any further since rear of horizontal tracks are not yet supported.

## ⚠ WARNING

**RAISING DOOR FURTHER CAN RESULT IN DOOR FALLING AND CAUSE SEVERE OR FATAL INJURY.**

Clamp a pair of vice clamps onto the vertical tracks just above the second track roller on one side, and just below the second track roller on the other side. This will prevent the door from raising or lowering while installing the rear back hangs.

Using the chart (Perforated Angle Gauge Weight Limitations) below, use the appropriate perforated angle (may not be supplied), (2) 5/16" x 1-5/8" hex head lag screws and (3) 5/16" bolts with nuts (may not be supplied), fabricate rear back hangs for the horizontal tracks. Attach the horizontal tracks to the rear back hangs with 5/16" - 18 x 1" hex bolts and nuts (may not be supplied). Horizontal tracks must be level and parallel with door within 3/4" to 7/8" maximum of door edge.

## ⚠ WARNING

**EXCEEDING THE RECOMMENDED LISTED DOOR WEIGHT LIMITATIONS OF SPECIFIC GAUGE PERFORATED ANGLES MAY RESULT IN DOOR FALLING WHEN RAISED, CAUSING SEVERE OR FATAL INJURY.**

## ⚠ WARNING

**VERIFY PERFORATED BACK HANG ANGLE LOAD RATINGS WITH BACK HANG ANGLE SUPPLIER.**

**Perforated Angle Gauge Weight Limitations:**

Perforated Angle Gauge	Door Weight
2" x 2" x 12 Gauge	Door Weight Less Than 800 lbs.
1-1/4" x 1-1/4" x 13 Gauge	Door Weight Less Than 305 lbs.
1-1/4" x 1-1/4" x 15 Gauge	Door Weight Less Than 220 lbs.
1-1/4" x 1-1/4" x 16 Gauge	Door Weight Less Than 175 lbs.

**NOTE:** If an opener is installed, position horizontal tracks one hole above level when securing it to the rear back hangs.

## ⚠ WARNING

**KEEP HORIZONTAL TRACKS PARALLEL AND WITHIN 3/4" TO 7/8" MAXIMUM OF DOOR EDGE, OTHERWISE DOOR COULD FALL, RESULTING IN SEVERE OR FATAL INJURY.**

**NOTE:** Doors heights over 8'0" or door widths over 11'0", require an additional set of rear center back hangs to be installed and located at the middle of the horizontal tracks, see parts breakdown.

Based on your door width and door heights and using perforated angle (may not be supplied), (2) 5/16" x 1-5/8" hex head lag screws and (3) 5/16" bolts with nuts (may not be supplied), fabricate rear center back hangs for the following:

**FOR ITEM J2, (SEE PARTS BREAKDOWN):** The Rear Center Back Hang Assemblies are to be used for all doors over 11'0" door height and over 14'0" door width. One Rear Center Back Hang Assembly, per side.

**FOR ITEM J3, (SEE PARTS BREAKDOWN):** The Rear Center Back Hang Assemblies are to be used for all doors over 16'0" door height. Two Rear Center Back Hang Assemblies, per side.

Measure and drill a 3/8" diameter hole through the center length of the horizontal track, as shown. Attach the rear center back hangs to the horizontal tracks with (1) 3/8" Truss head bolt and (1) 3/8" nut (may not be supplied).

**IMPORTANT:** DO NOT SUPPORT THE WEIGHT OF THE DOOR ON ANY PART OF THE REAR BACK HANGS THAT CANTILEVERS 4" OR MORE BEYOND A SOUND FRAMING MEMBER.

**NOTE:** If rear back hangs are to be installed over drywall, use (2) 5/16" x 2" hex head lag screws and make sure lag screws engage into solid structural lumber.

**NOTE:** 26" angle must be attached to sound framing members and **nails should not be used.**

Now, permanently attach the weatherstrips on both door jambs and header. The weatherstrips were temporarily attached in Preparing the Opening, in the pre-installation section of this manual.

**NOTE:** When permanently attaching the weatherstrips to the jambs, avoid pushing the weatherstrips too tightly against the face of door.

## ⚠ WARNING

**PRIOR TO WINDING OR MAKING ADJUSTMENTS TO THE SPRINGS, ENSURE YOU'RE WINDING IN THE PROPER DIRECTION AS STATED IN THE INSTALLATION INSTRUCTIONS. OTHERWISE THE SPRING FITTINGS MAY RELEASE FROM SPRING IF NOT WOUND IN THE PROPER DIRECTION AND COULD RESULT IN SEVERE OR FATAL INJURY.**

Now, lift door and check its balance. Adjustments to the required number of spring turns stated may be necessary. If door rises off floor under spring tension alone, reduce spring tension until door rests on the floor. If the door is hard to rise or drifts down on its own, add spring tension. A poorly balanced door can cause garage door operator operation problems.

To adjust spring tension, fully close door. Apply vice grips to track above third track roller. Insert a winding rod into the winding cone. On single spring doors, counterbalance lift cable tension must be maintained by placing vice grips on torsion shaft before loosening set screws in the winding cone. Push upward on the winding rod while carefully loosening the set screws in the winding cone. BE PREPARED TO SUPPORT THE FULL FORCE OF THE TORSION SPRING ONCE THE SET SCREWS ARE LOOSE. Carefully adjust spring tension 1/4 turn. Retighten both set screws in the winding cone and repeat for the other side. Recheck door balance. DO NOT ADJUST MORE THAN 1/2 TURN FROM THE RECOMMENDED NUMBER OF TURNS.

If the door still does not operate easily, lower the door into the closed position, UNWIND THE SPRING(S) FULLY (Reference the insert "Removing The Old Door / Preparing The Opening" section on torsion spring removal) and recheck the following the items:

- 1.) Check the door for level.
- 2.) Check the torsion shaft for level.
- 3.) Check the track spacing.
- 4.) Check the counterbalance cables for equal tension and proper wrap onto the cable drums.
- 5.) Check the track for potential obstruction of the track rollers.
- 6.) Clamp locking pliers onto track and rewind springs.
- 7.) Lubricate hinges, steel rollers, and torsion springs with non-silicon based lubricant or silicon.

**IMPORTANT:** IF DOOR STILL DOES NOT OPERATE PROPERLY, THEN CONTACT A TRAINED DOOR SYSTEM TECHNICIAN.

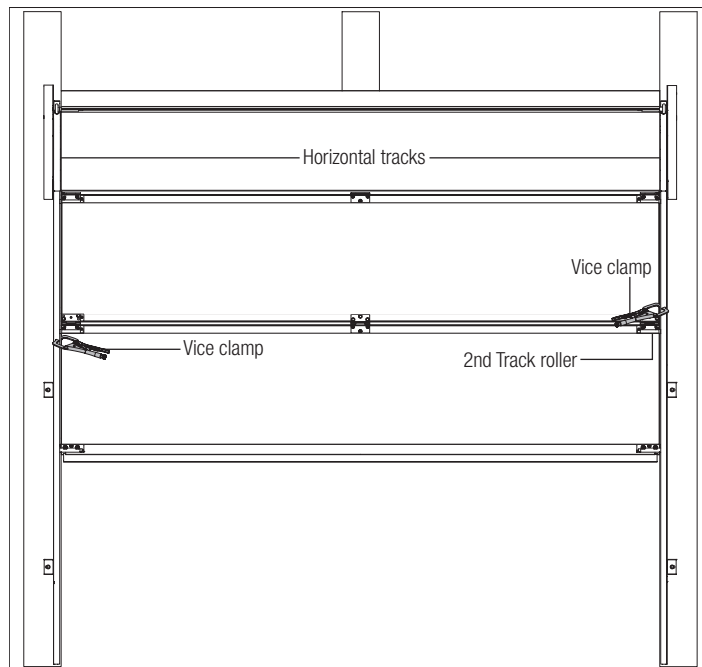

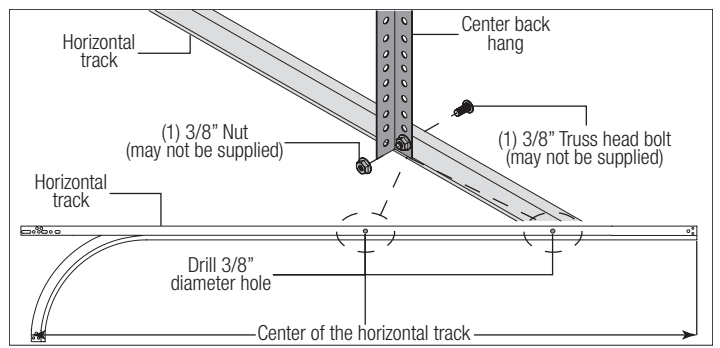
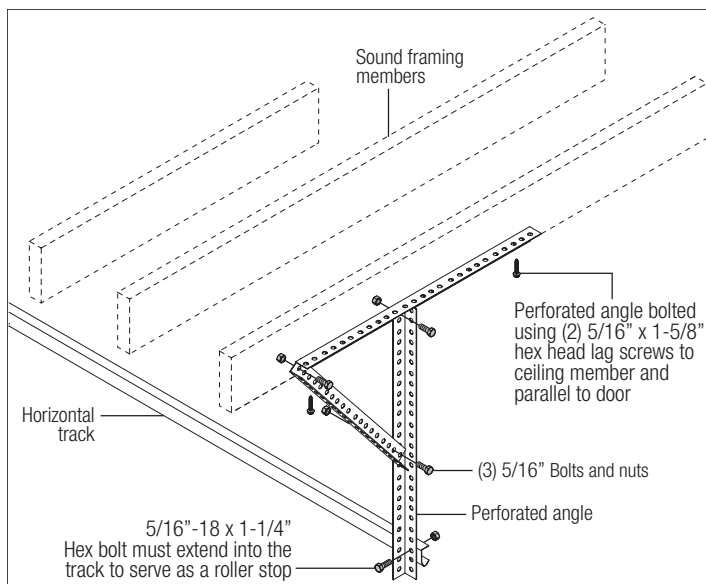

## 27 Cable Keepers

Tools Required: Safety glasses

**NOTE:** If you don't have cable keepers, then skip this step. Refer to Step 3 Cable Keepers, to determine if you have cable keepers installed.

**IMPORTANT:** CABLE KEEPERS ARE INTENDED TO KEEP COUNTERBALANCE LIFT CABLES FROM COMING OFF CABLE DRUMS ON MANUALLY OPERATED DOORS.

Rotate arm up and hook around counterbalance lift cable, letting the cable keeper arm pull against the counterbalance lift cable, keeping it taut, as shown. Next, close the hook to prevent the counterbalance lift cables from coming out.

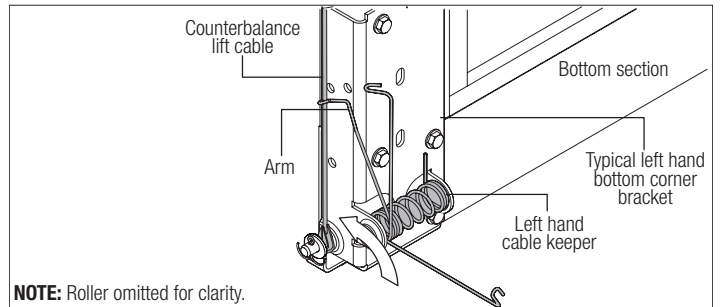
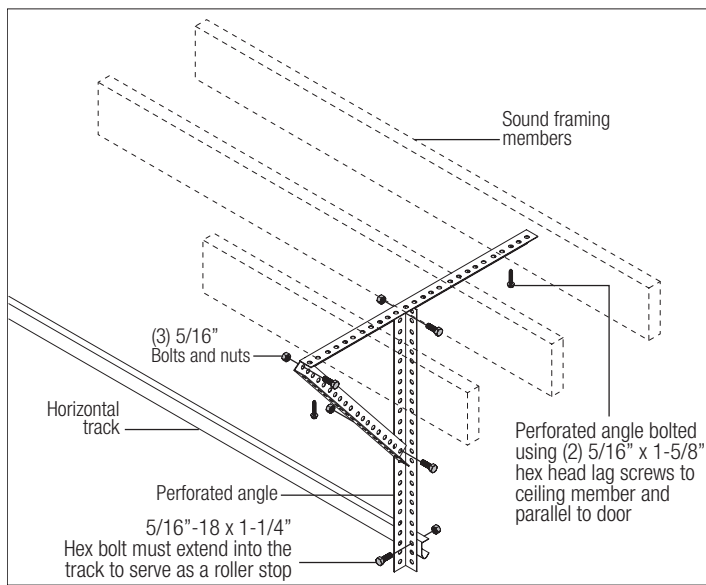

**NOTE:** Roller omitted for clarity.

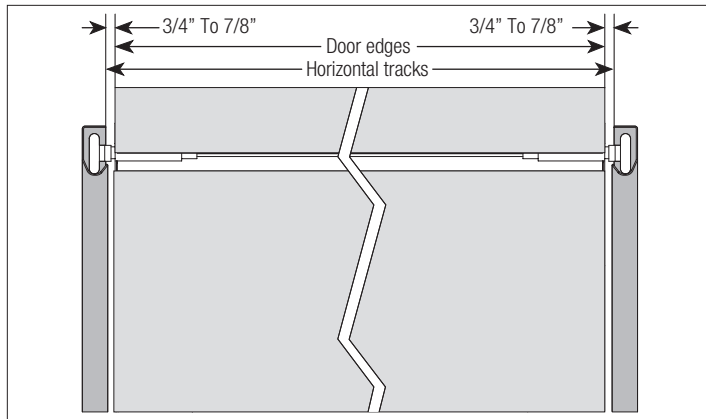

### Inside Lock

Install the inside lock on the second section of the door. Secure the lock to the section with (4) 1/4" - 20 x 5/8" self drilling screws. Square the lock assembly with the door section, and align with the square hole in the vertical track. The inside lock should be spaced approximately 1/8" away from the section edge.

**IMPORTANT:** INSIDE LOCK(S) MUST BE REMOVED OR MADE INOPERATIVE IN THE UNLOCKED POSITION IF AN OPERATOR IS INSTALLED ON THIS DOOR.

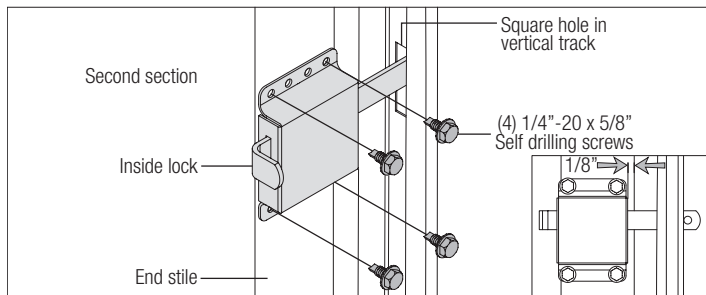

### Step Plate

Position your step plate on the inside of the door over the bottom section endstile and on the side of the door containing the side lock. Secure the step plate to endstile using (2) 1/4" - 20 x 5/8" self-drilling screws, as shown. For doors ordered with non-keyed locks, a second step plate is provided. Install the second step plate in the same manner as the first on the lock section (second section), below the side lock.

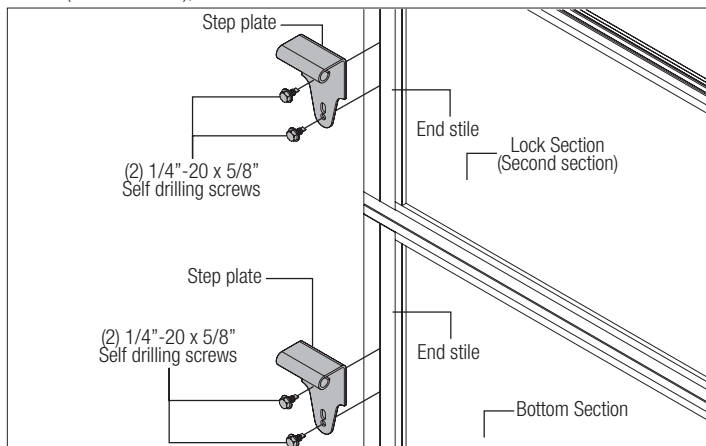

### Pull Down Rope

## WARNING

**DO NOT INSTALL PULL DOWN ROPE ON DOORS WITH OPERATORS. CHILDREN MAY BECOME ENTANGLED IN THE ROPE CAUSING SEVERE OR FATAL INJURY.**

Measure and mark the jamb approximately 48" to 50" (1220 to 1270 mm) from floor on the right or left side of jamb. Drill 1/8" pilot hole for no. 6 screw eye. Tie the pull down rope to the no. 6 screw eye and to the bottom corner bracket, as shown.

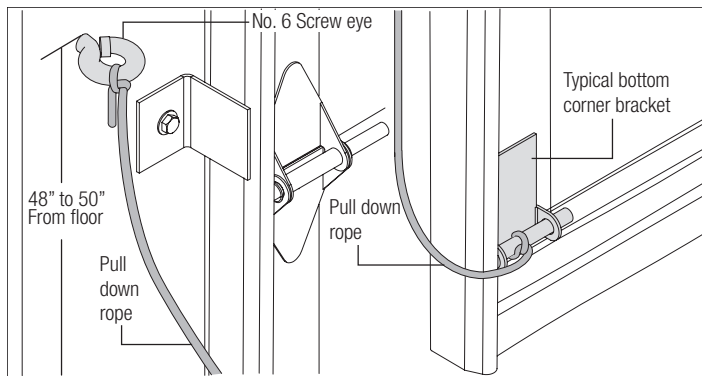

### Exhaust Port

Using the illustrations below, locate and install the exhaust port assembly to the bottom section, using #10 counter sunk bolts and #10 hex nuts, as shown.

**NOTE:** The exhaust port goes on the inside of the bottom section and can be installed into the aluminum panel or on a double wide bottom rail.

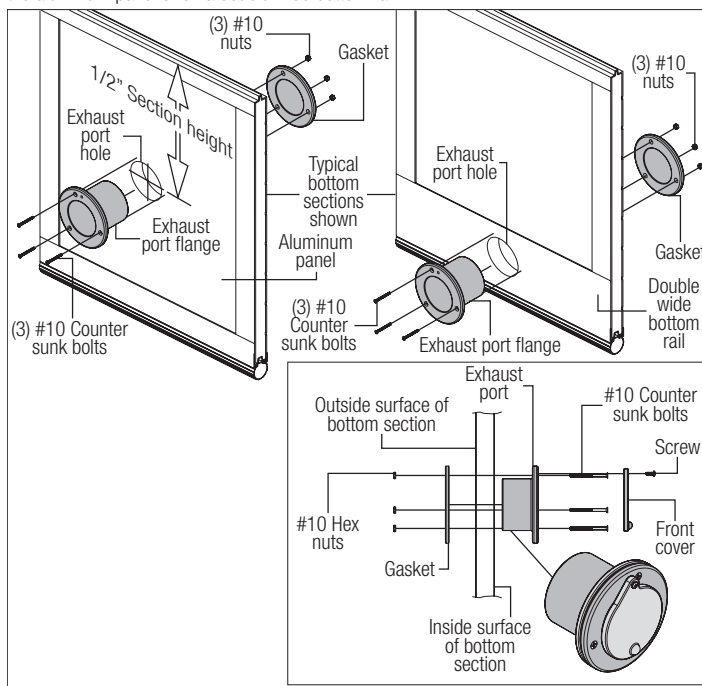

### Chain Hoist

#### Chain Hoist Installation (Standard Lift Applications only!)

**NOTE:** Reference separate instructions for Chain Hoists and Jack Shaft Operators installation instruction.

Chain Hoists and Jack Shaft Operators are limited to:

- 1.) Standard Lift Doors with roof pitch track 2:12 or greater.
- 2.) High Lift track greater than or equal to 24".
- 3.) High Lift track 12" thru 24" with roof pitch track 1:12.

**IMPORTANT:** IF YOUR DOOR IS TO BE TROLLEY OPERATED, IT IS RECOMMENDED THAT A OPTIONAL STRUT BE INSTALLED ON THE TOP SECTION.

## ⚠ WARNING

WAYNE DALTON RECOMMENDS THE USE OF A TROLLEY RAIL(S) AND AUXILIARY SHAFT FOR STANDARD OR HIGH LIFT DOORS BELOW THESE LIMITS. CABLE KEEPERS ARE RECOMMENDED FOR ALL CHAIN HOIST OR JACKSHAFTS OPERATORS. INSTALL THE CHAIN HOIST OR SPROCKET AS CLOSE TO THE END BEARING BRACKET AS POSSIBLE, TO MINIMIZE TORSION SHAFT DEFLECTION. CHAIN TENSIONERS ARE RECOMMENDED FOR DOORS OVER 144 SQ. FT. WITH JACKSHAFT OPERATORS.

## ⚠ WARNING

WAYNE DALTON RECOMMENDS THE USE OF A TROLLEY RAIL(S) COUPLED TO AN AUXILIARY SHAFT THAT IS POWERED BY A SIDE MOUNT TYPE CHAIN HOIST.

**NOTE:** 9" of extra headroom are required for these installations.

Assemble the trolley rail as per the manufactures installation instructions.

**NOTE:** Back hang the trolley using angles, center hang supports are required for doors over 14' wide and 12' high.

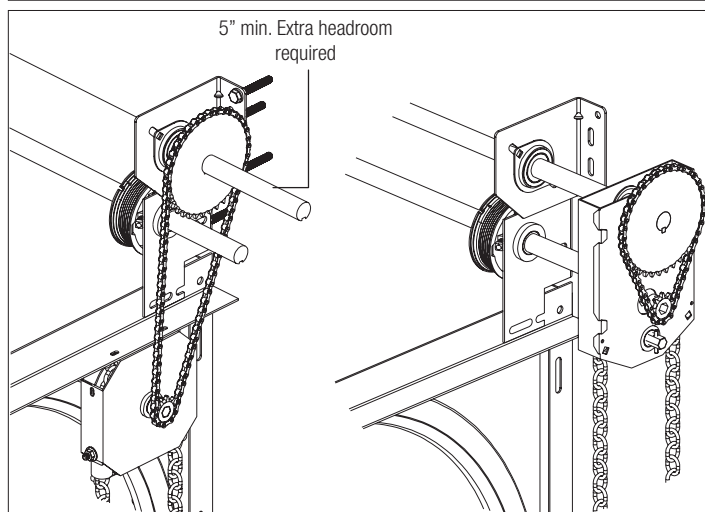
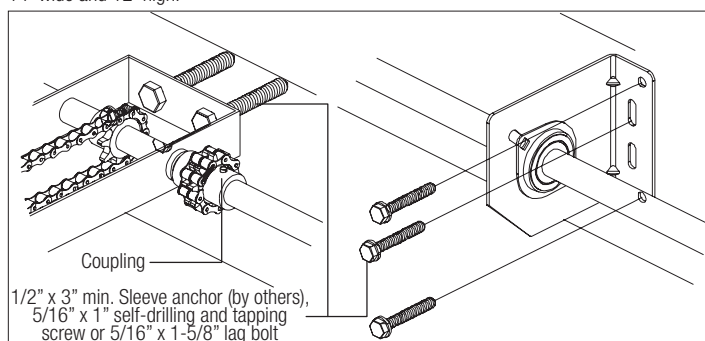

**NOTE:** Install Sprocket or chain hoist as close to track as possible, minimum of 3/4", to minimize shaft deflection.

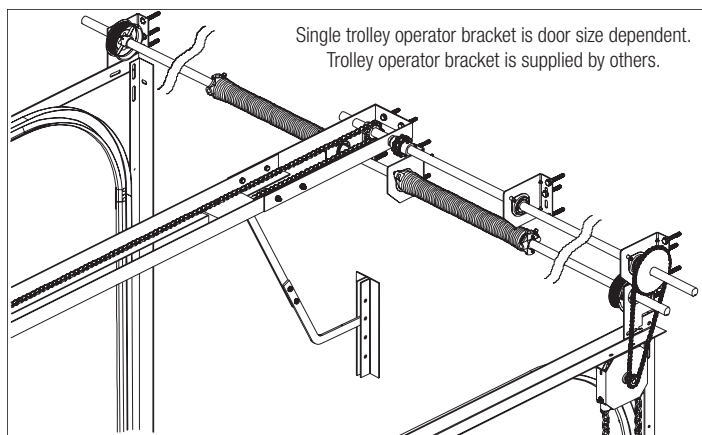
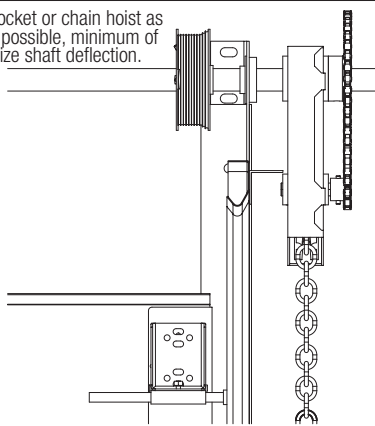

## Pusher Springs

**IMPORTANT:** RIGHT AND LEFT HAND IS ALWAYS DETERMINED FROM INSIDE THE BUILDING LOOKING OUT.

Raise the door until bottom section is 3/4" below header. Starting on the left hand side, align the pusher spring with the top corner of the top section, as shown. Compress the pusher spring against the top fixture flange. Mark and drill (2) 3/8" dia. holes into the horizontal track. Secure the pusher spring bracket to the horizontal track using (2) 3/8" x 1-1/4" hex head bolts and nuts. Repeat same process for the right hand side.

**NOTE:** The (2) 3/8" x 1-1/4" hex head bolts may extend into the horizontal track.

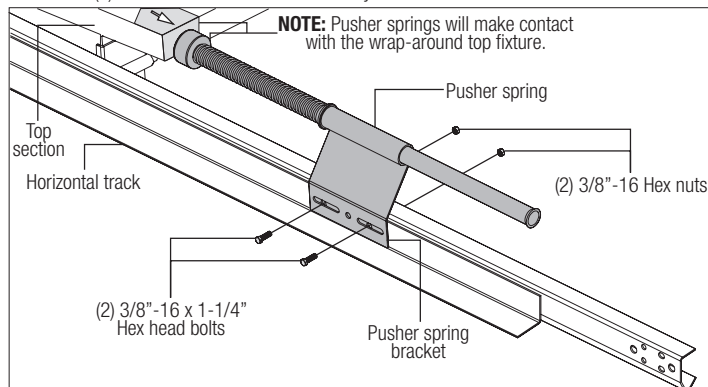

## Cleaning Your Garage Door

Like any other exterior surface, Wayne Dalton garage doors will have dirt exposure from atmospheric conditions. Ordinarily, the cleaning action of rainfall will be adequate to wash the door, or the door can be washed periodically by hosing with a garden hose and clear water (in particular) for the areas not accessible to rain. If you desire to do a more thorough cleaning, or where soil collection conditions occur, follow these simple instructions.

1. To clean acrylic glazings wash with plenty of nonabrasive soap or detergent and water. Use the bare hand to feel and dislodge any caked dirt or mud. A soft, grit-free cloth, sponge or chamois may be used to wipe the surface. Do not use hard or rough cloth that will scratch the acrylic glazing. Dry with a clean damp chamois.

2. Grease and oil may be removed with kerosene or a good grade of naphtha (No aromatic content.). Users of these solvents should become familiar with their proper ties to handle them safely.

Mild solutions of detergents or household ammonia will aid in the removal of most dirt, and the following are recommended levels:

One cup of Tide™, or other common detergents, which contain less than 0.5% phosphate, dissolved into five gallons of warm water.

**NOTE:** The use of detergents containing greater than 0.5% phosphate is not recommended for use in general cleaning of garage doors. NEVER BLEND CLEANSERS OR DETERGENTS WITH BLEACH.

3. Do not use: Window cleaning fluids, scouring compounds, gritty cloths, leaded or ethyl gasoline, or solvents such as alcohol, acetone, carbon tetrachloride, etc.

This cleaning and maintenance information is suggested in an effort to be of assistance; however, manufacturer cannot assume responsibility for results obtained which are dependent on the cleaning solution and method of application.

## Operation And Maintenance

### OPERATING YOUR GARAGE DOOR:

Before you begin, read all warning labels affixed to the door and the installation instructions and owner's manual. When correctly installed, your Wayne Dalton door will operate smoothly. Always operate your door with controlled movements. Do not slam your door or throw your door into the open position, this may cause damage to the door or its components. If your door has an electric opener, refer to the owner's manual to disconnect the opener before performing manual door operation below.

#### MANUAL DOOR OPERATION:

For additional information on manual garage door operations go to [www.dasma.com](http://www.dasma.com) and reference TDS 165.

**IMPORTANT:** DO NOT PLACE FINGERS OR HANDS INTO SECTION JOINTS WHEN OPENING AND/OR CLOSING A DOOR. ALWAYS USE LIFT HANDLES / SUITABLE GRIPPING POINTS WHEN OPERATING THE DOOR MANUALLY.

Opening a Door: Make sure the lock(s) are in the unlocked position. Lift the door by using the lift handles / suitable gripping points only. Door should open with little resistance.

Closing a Door: From inside the garage, pull door downward using lift handles / gripping points only or a high friction area only. If you are unable to reach the lift handles/ suitable gripping points only, use pull down rope affixed to the side of door. Door should close completely with little resistance.

#### USING AN ELECTRIC OPERATOR:

**IMPORTANT:** PULL DOWN ROPES MUST BE REMOVED AND LOCKS MUST BE REMOVED OR MADE INOPERATIVE IN THE UNLOCKED POSITION.

When connecting a drawbar (trolley type) garage door operator to this door, a drawbar operator and or drawbar operator bracket must be securely attached to the top section of the door, along with any struts provided with the door. Always use the drawbar operator and or drawbar operator bracket supplied with the door. To avoid possible damage to your door, Wayne Dalton recommends reinforcing the top section with a strut (may or may not be supplied). The installation of the drawbar operator must be according to manufacturer's instructions and force settings must be adjusted properly. Refer to the owner's manual supplied with your drawbar operator for complete details on installation, operation, maintenance and testing of the operator.

#### MAINTAINING YOUR GARAGE DOOR:

Before you begin, read all warning labels affixed to the door and the installation instructions and owner's manual. Perform routine maintenance steps once a month, and have the door professionally inspected once a year. Review your Installation Instructions and Owner's Manual for the garage door. These instructions are available at no charge from Wayne Dalton, A Division Of Overhead Door Corporation, P.O. Box 67, Mt. Hope, OH., 44660, or at [www.wayne-dalton.com](http://www.wayne-dalton.com). For additional information on garage door/operator maintenance go to [www.dasma.com](http://www.dasma.com) and reference TDS 151, 167 and 179.

#### MONTHLY INSPECTIONS:

**1. Visual Inspection:** Closely inspect jambs, header and mounting surface. Any wood found not to be structurally sound must be replaced. Inspect the springs, counterbalance lift cables, track rollers, pulleys, rear back hangs and other door hardware for signs of worn or broken

parts. Tighten any loose screws and/or bolts. Check exterior surface of the door sections for any minor cracks. Verify door has not shifted right or left in the opening. If you suspect problems, have a trained door system technician make the repairs.

### WARNING

**GARAGE DOOR SPRINGS, COUNTERBALANCE LIFT CABLES, BRACKETS, AND OTHER HARDWARE ATTACHED TO THE SPRINGS ARE UNDER EXTREME TENSION, AND IF HANDLED IMPROPERLY, CAN CAUSE SEVERE OR FATAL INJURY. ONLY A TRAINED DOOR SYSTEMS TECHNICIAN SHOULD ADJUST THEM, BY CAREFULLY FOLLOWING THE MANUFACTURER'S INSTRUCTIONS.**

### WARNING

**NEVER REMOVE, ADJUST, OR LOOSEN THE BOLTS, SCREWS AND/OR LAG SCREWS ON THE COUNTERBALANCE (END OR CENTER BEARING BRACKETS) SYSTEM OR BOTTOM CORNER BRACKETS OF THE DOOR. THESE BRACKETS ARE CONNECTED TO THE SPRING(S) AND ARE UNDER EXTREME TENSION. TO AVOID POSSIBLE SEVERE OR FATAL INJURY, HAVE ANY SUCH WORK PERFORMED BY A TRAINED DOOR SYSTEMS TECHNICIAN USING PROPER TOOLS AND INSTRUCTIONS.**

Torsion Springs: The torsion springs (located above the door) should only be adjusted by a trained door systems technician. DO NOT attempt to repair or adjust torsion springs yourself.

Extension Springs: A restraining cable or other device should be installed on the extension spring (located above the horizontal tracks) to help contain the spring if it breaks.

**2. Door Balance:** Periodically test the balance of your door. If you have a garage door drawbar operator, use the release mechanism so you can operate the door by hand when doing this test. Start with the door in the fully closed position. Lift the door to check its balance. Adjust Extension spring(s), if door lifts by itself (hard to pull down) or if door is difficult to lift (easy to pull down). DO NOT attempt to repair or adjust Torsion Springs yourself. To adjust Extension spring(s), refer to your installation instructions and owner's manual. If in question about any of the procedures, do not perform the work. Instead, have it adjusted by a trained door systems technician.

**3. Lubrication:** The door should open and close smoothly. Ensure the door track rollers are rotating freely when opening and closing the door. If track rollers do not rotate freely, clean the door tracks, removing dirt and any foreign substances. Clean and lubricate (use a non-silicon based lubricant) graduated end hinges, center hinge(s), steel track rollers, bearings and torsion spring(s) (torsion spring coil surfaces). DO NOT lubricate plastic idler bearings, nylon track rollers, door track. DO NOT oil a cylinder lock, if actuation is difficult use a graphite dust to lubricate.

**Limited Warranty**

**Aluminum Full View Models: 8440, 464, 451, 452 And K-AL**

Wayne Dalton, a division of Overhead Door Corporation (“Seller”) warrants to the original purchaser of the Full View Models, 8440, 464, 451 or 452, or K-AL (available on West Coast) Commercial Sectional Doors (“Product”), subject to all of the terms and conditions hereof, that the Product and all components thereof will be free from defects in materials and workmanship for the following period(s) of time, measured from the date of installation:

- **ONE (1) YEAR** against defects in materials and workmanship.

Seller’s obligation under this warranty is specifically limited to repairing or replacing, at its option, any part which is determined by Seller to be defective during the applicable warranty period. Any labor charges are excluded and will be the responsibility of the purchaser.

This warranty is made to the original purchaser of the Product only, and is not transferable or assignable. This warranty does not apply to any unauthorized alteration or repair of the Product, or to any Product or component which has been damaged or deteriorated due to misuse, neglect, accident, failure to provide necessary maintenance, normal wear and tear, acts of God, or any other cause beyond the reasonable control of Seller or as a result of having been exposed to toxic or abrasive environments, including blowing sand, salt water, salt spray and toxic chemicals and fumes.

THIS WARRANTY IS EXCLUSIVE AND IN LIEU OF ANY OTHER WARRANTIES, EITHER EXPRESSED OR IMPLIED, INCLUDING BUT NOT LIMITED TO ANY IMPLIED WARRANTY OF MERCHANTABILITY OR FITNESS FOR A PARTICULAR PURPOSE. IN NO EVENT SHALL SELLER BE RESPONSIBLE FOR, OR LIABLE TO ANYONE FOR, SPECIAL, INDIRECT, COLLATERAL, PUNITIVE, INCIDENTAL OR CONSEQUENTIAL DAMAGES, even if Seller has been advised of the possibility of such damages. Such excluded damages include, but are not limited to, loss of use, cost of any substitute product, or other similar indirect financial loss.

Claims under this warranty must be made promptly after discovery, within the applicable warranty period, and in writing to the authorized dealer or installer whose name and address appear below. The purchaser must allow Seller a reasonable opportunity to inspect any Product claimed to be defective prior to removal or any alteration of its condition. Proof of the purchase and/or installation date, and identification as the original purchaser, may be required.

• SELLER: \_\_\_\_\_

• SELLER’S ADDRESS: \_\_\_\_\_  
\_\_\_\_\_





---

Thank you for your purchase.

---

Please Do Not Return This Product To The Store. Please call 1-866-569-3799 (Press Option 1) and follow the prompts to contact the appropriate customer service agent. They will be happy to handle any questions that you may have.

---

AFTER INSTALLATION IS COMPLETE, FASTEN THIS  
MANUAL NEAR GARAGE DOOR FOR EASY REFERENCE.